

# WiBotic Inc.

REVISED TEST REPORT TO 103494-35

**OC-251\***

(\*See Appendix A for Manufacturer Declaration)

Tested to The Following Standards:

FCC Part 15 Subpart C Section(s)

15.249

Report No.: 103494-34A

Date of issue: July 13, 2020



Test Certificate # 803.01

This test report bears the accreditation symbol indicating that the testing performed herein meets the test and reporting requirements of ISO/IEC 17025 under the applicable scope of testing for CKC Laboratories, Inc.

We strive to create long-term, trust based relationships by providing sound, adaptive, customer first testing services. We embrace each of our customers' unique EMC challenges, not as an interruption to set processes, but rather as the reason we are in business.

**TABLE OF CONTENTS**

Administrative Information ..... 3

    Test Report Information ..... 3

    Revision History ..... 3

    Report Authorization ..... 3

    Test Facility Information ..... 4

    Software Versions ..... 4

    Site Registration & Accreditation Information ..... 4

    Summary of Results ..... 5

    Modifications During Testing ..... 5

    Conditions During Testing ..... 5

    Equipment Under Test ..... 6

    General Product Information ..... 6

FCC Part 15 Subpart C ..... 9

    15.215(c) Occupied Bandwidth (20dB BW) ..... 9

    15.249(a) Field Strength of Fundamental ..... 12

    15.249(a) Radiated Emissions and Band Edge ..... 18

Appendix A: Manufacturer Declaration ..... 33

Supplemental Information ..... 34

    Measurement Uncertainty ..... 34

    Emissions Test Details ..... 34

## ADMINISTRATIVE INFORMATION

### Test Report Information

**REPORT PREPARED FOR:**

WiBotic Inc.  
9706 - 4th Ave. NE  
Seattle, WA 98115

Representative: Patrick Vilbrandt  
Customer Reference Number: 1220 Rev 2

**DATE OF EQUIPMENT RECEIPT:**

**DATE(S) OF TESTING:**

**REPORT PREPARED BY:**

Darcy Thompson  
CKC Laboratories, Inc.  
5046 Sierra Pines Drive  
Mariposa, CA 95338

Project Number: 103494

May 13, 2020

May 13, 2020, June 3, 2020 and July 1, 2020

### Revision History

**Original:** Testing of the OC-251 to FCC Part 15 Subpart C Section(s) 15.249.

**Revision A:** To update General Product Information Table Nominal Input Voltage from 24V battery to 60V battery. Added Configuration 2, added statement in the test sections and Conditions During test for the testing with the 60V battery.

### Report Authorization

The test data contained in this report documents the observed testing parameters pertaining to and are relevant for only the equipment provided by the client, tested in the agreed upon operational mode(s) and configuration(s) as identified herein. Compliance assessment remains the client's responsibility. This report may not be used to claim product endorsement by A2LA or any government agencies. This test report has been authorized for release under quality control from CKC Laboratories, Inc.



**Steve Behm**  
*Director of Quality Assurance & Engineering Services*  
*CKC Laboratories, Inc.*

## Test Facility Information



Our laboratories are configured to effectively test a wide variety of product types. CKC utilizes first class test equipment, anechoic chambers, data acquisition and information services to create accurate, repeatable and affordable test results.

TEST LOCATION(S):  
CKC Laboratories, Inc.  
22116 23rd Drive S.E., Suite A  
Canyon Park, Bothell, WA 98021

## Software Versions

CKC Laboratories Proprietary Software	Version
EMITest Emissions	5.03.12

## Site Registration & Accreditation Information

Location	*NIST CB #	FCC	Japan
Canyon Park, Bothell, WA	US0081	US1022	A-0136
Brea, CA	US0060	US1025	A-0136
Fremont, CA	US0082	US1023	A-0136
Mariposa, CA	US0103	US1024	A-0136

\*CKC's list of NIST designated countries can be found at: <https://standards.gov/cabs/designations.html>

## SUMMARY OF RESULTS

### Standard / Specification: FCC Part 15 Subpart C - 15.249

Test Procedure	Description	Modifications	Results
15.215(c)	Occupied Bandwidth	NA	
15.249(a)	Field Strength of Fundamental	NA	
15.249(a)	Radiated Emissions and Band Edge	NA	
15.207	AC Conducted Emissions	NA	NA1

NA = Not Applicable

NA1 = The manufacturer declares the EUT is battery powered.

#### ISO/IEC 17025 Decision Rule

The declaration of pass or fail herein is based upon assessment to the specification(s) listed above, including where applicable, assessment of measurement uncertainties. For performance related tests, equipment was monitored for specified criteria identified in that section of testing.

### Modifications During Testing

This list is a summary of the modifications made to the equipment during testing.

#### Summary of Conditions

No modifications were made during testing.

**Modifications listed above must be incorporated into all production units.**

### Conditions During Testing

This list is a summary of the conditions noted to the equipment during testing.

#### Summary of Conditions

Testing was performed on July 1, 2020 with Configuration 2 with a 60V battery and no changes in TX power were observed.

## EQUIPMENT UNDER TEST (EUT)

During testing, numerous configurations may have been utilized. The configurations listed below support compliance to the standard(s) listed in the Summary of Results section.

### Configuration 1

**Equipment Tested:**

Device	Manufacturer	Model #	S/N
OC-251-12-ST	WiBotic Inc.	OC-251*	001

\* See Appendix A for Manufacturer Declaration

**Support Equipment:**

Device	Manufacturer	Model #	S/N
24V Lithium Iron Phosphate Battery	Bioenno Power	BLF-2440A	NA
RC-100-AP-ST	WiBotic Inc.	RC-100	NA

### Configuration 2

**Equipment Tested:**

Device	Manufacturer	Model #	S/N
OC-251-12-ST	WiBotic Inc.	OC-251*	001

\* See Appendix A for Manufacturer Declaration

**Support Equipment:**

Device	Manufacturer	Model #	S/N
Lithium Iron Phosphate Battery	Bioenno Power	BLF-4810W	NA
RC-100-AP-ST	WiBotic Inc.	RC-100	NA

## General Product Information:

Product Information	Manufacturer-Provided Details
Equipment Type:	Radio Module
Modulation Type(s):	GFSK 250kbps
Maximum Duty Cycle:	100%
Antenna Type(s) and Gain:	Chip antenna 1dBi
Antenna Connection Type:	Integral
Nominal Input Voltage:	60V battery
Firmware / Software used for Test:	V11.1

**EUT Photo(s)**



**Support Equipment Photo(s)**



**Block Diagram of Test Setup(s)**

**Test Setup Block Diagram**

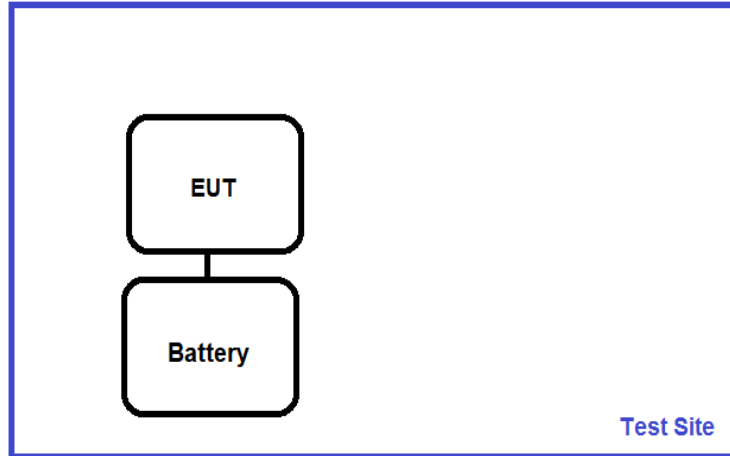



## FCC Part 15 Subpart C

### 15.215(c) Occupied Bandwidth (20dB BW)

Test Setup/Conditions			
Test Location:	Bothell Lab C3	Test Engineer:	S. Pittsford
Test Method:	ANSI C63.10 (2013)	Test Date(s):	5/13/2020 and 7/1/2020
Configuration:	1		
Test Setup:	Continuously transmitting all 0 Data EUT is located on test bench 0.8m high <1GHz and 1.5m high >1GHz . A laptop is temporarily connected to change transmitter settings and removed during test. EUT is powered via a fully charged battery pack.  Testing was performed on July 1, 2020 with Configuration 2 with a 60V battery and no changes in TX power were observed.		

Environmental Conditions			
Temperature (°C)	24	Relative Humidity (%):	34

Test Equipment					
Asset#	Description	Manufacturer	Model	Cal Date	Cal Due
01467	Horn Antenna	EMCO	3115	7/5/2019	7/5/2021
02673	Spectrum Analyzer	Agilent	E4446A	2/22/2019	2/22/2021
P06515	Cable	Andrews	Heliac	6/29/2018	6/29/2020
P06540	Cable	Andrews	Heliac	8/23/2019	8/23/2021
03540	Preamp	HP	83017A	5/13/2019	5/13/2021
P07504	Cable	TMS	CLU40-KMKM-02.00F	1/17/2019	1/17/2021

Test Data Summary					
Frequency (MHz)	Antenna Port	Modulation	Measured (kHz)	Limit (kHz)	Results
2433.03	1	GFSK	540.7	None	NA
2457.36	1	GFSK	539.4	None	NA
2481.68	1	GFSK	537.7	None	NA

NA = Not applicable, because FCC 15.215 does not give any limits so there is no criteria for pass or fail.

**Plot(s)**

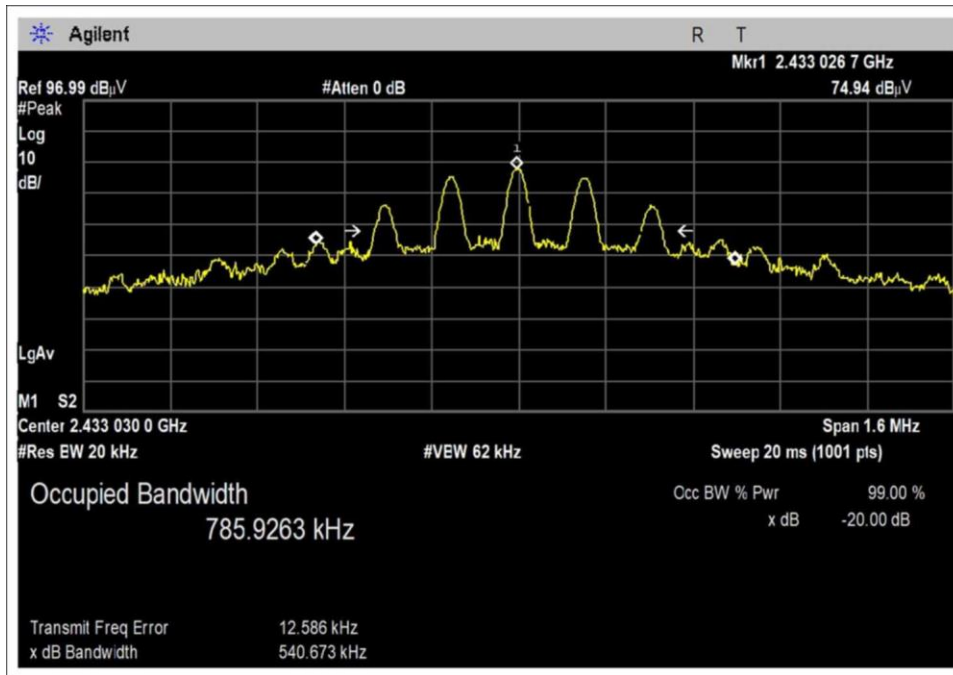

Low Channel

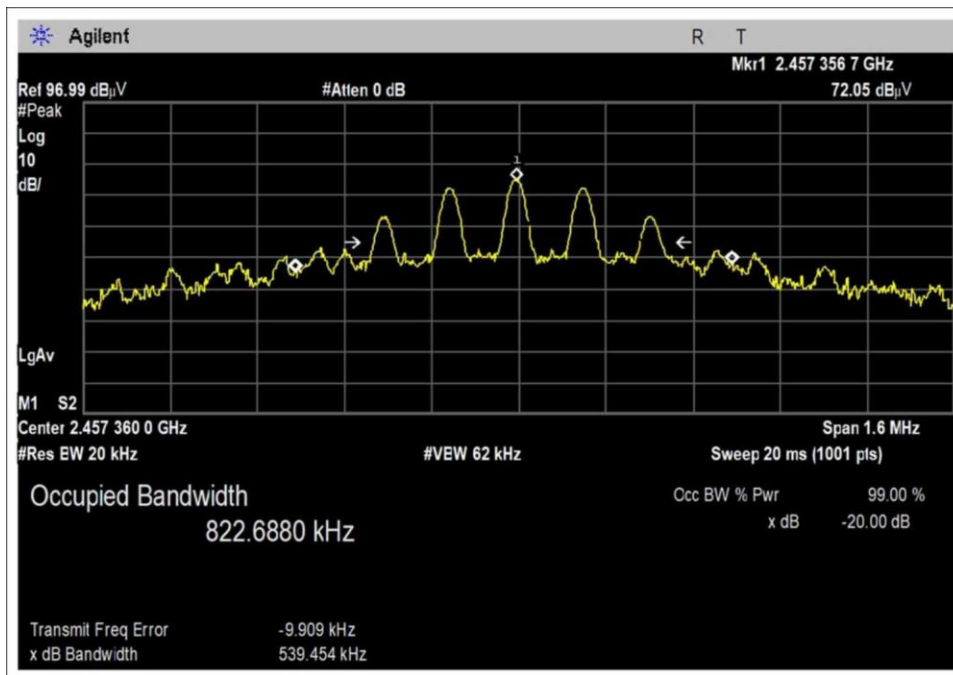

Middle Channel

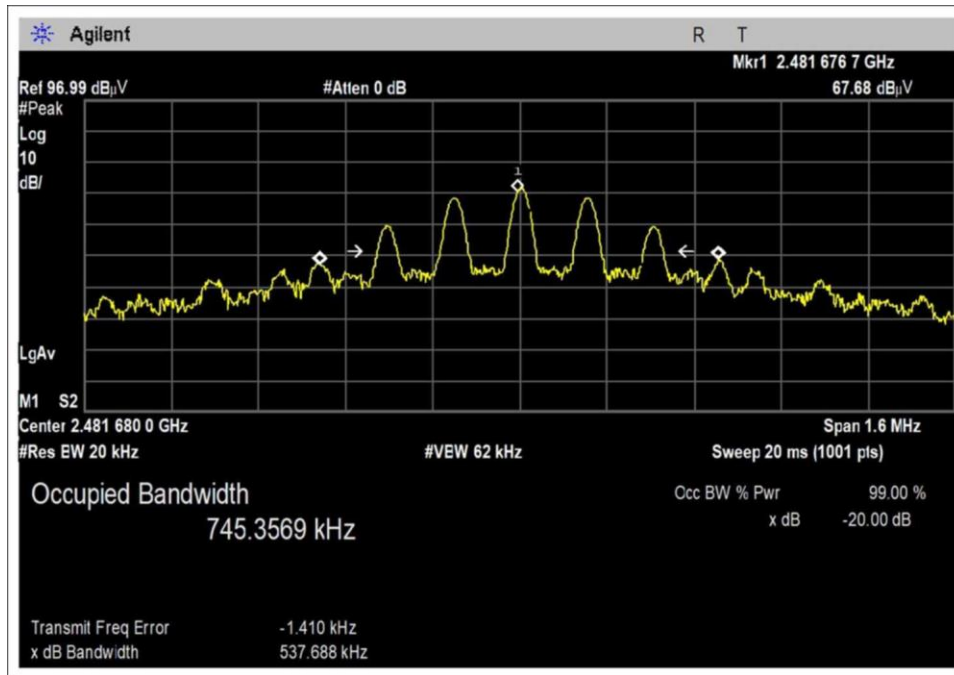

High Channel

**Test Setup Photo(s)**

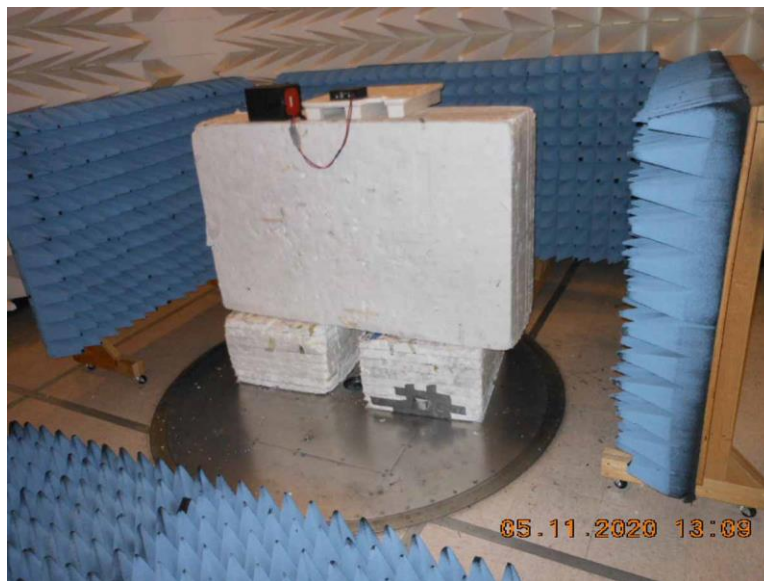

## 15.249(a) Field Strength of Fundamental

### Test Data Summary - Voltage Variations

This equipment is battery powered. Power output tests were performed using a fresh battery.

Testing was performed on July 1, 2020 with Configuration 2 with a 60V battery and no changes in TX power were observed.

### Test Data Summary – Radiated Field Strength Measurement

Frequency (MHz)	Modulation	Ant. Type	Measured (dBuV/m @ 3m)	Limit (dBuV/m @ 3m)	Results
2433.03	GFSK	Integral	79.5	≤94	Pass
2457.36	GFSK	Integral	80.0	≤94	Pass
2481.68	GFSK	Integral	80.3	≤94	Pass

Plots shows raw reading please see datasheet for corrected readings.

50mV/m = 94dBuV/m

### Plot(s)

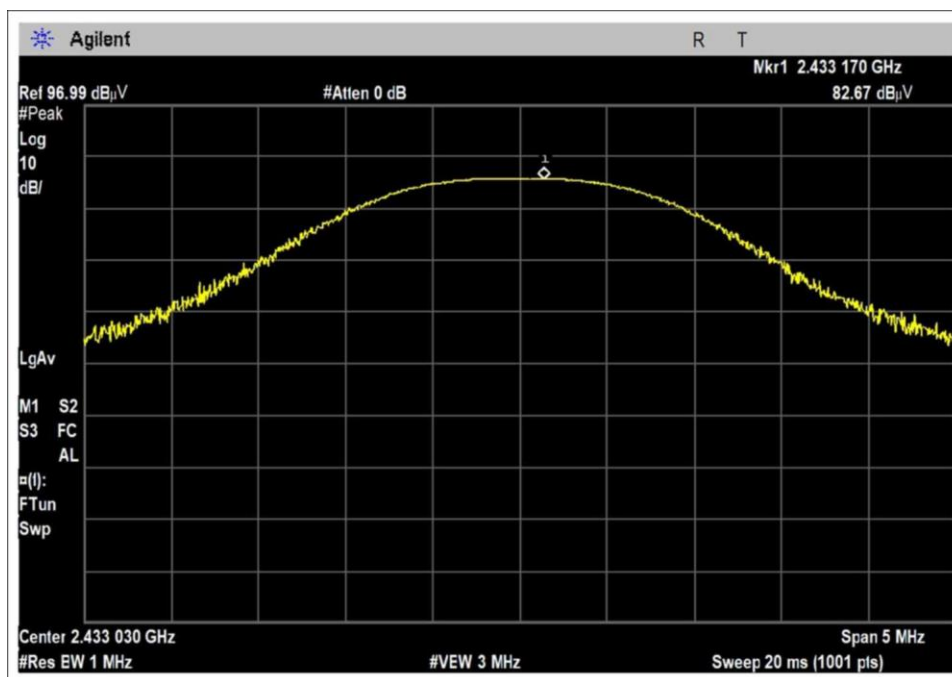

Low Channel

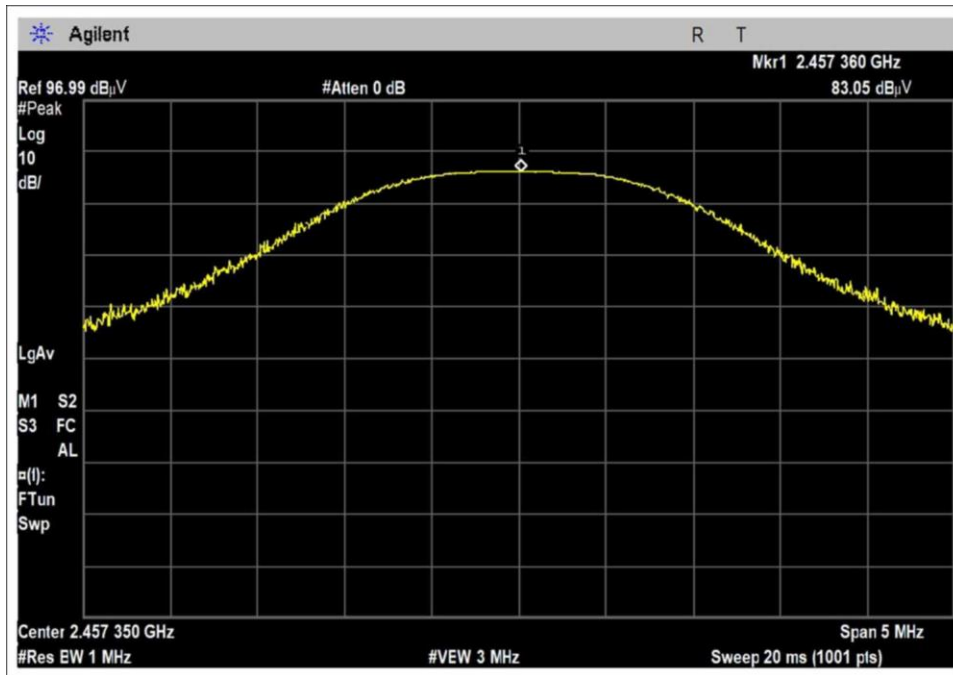

Middle Channel

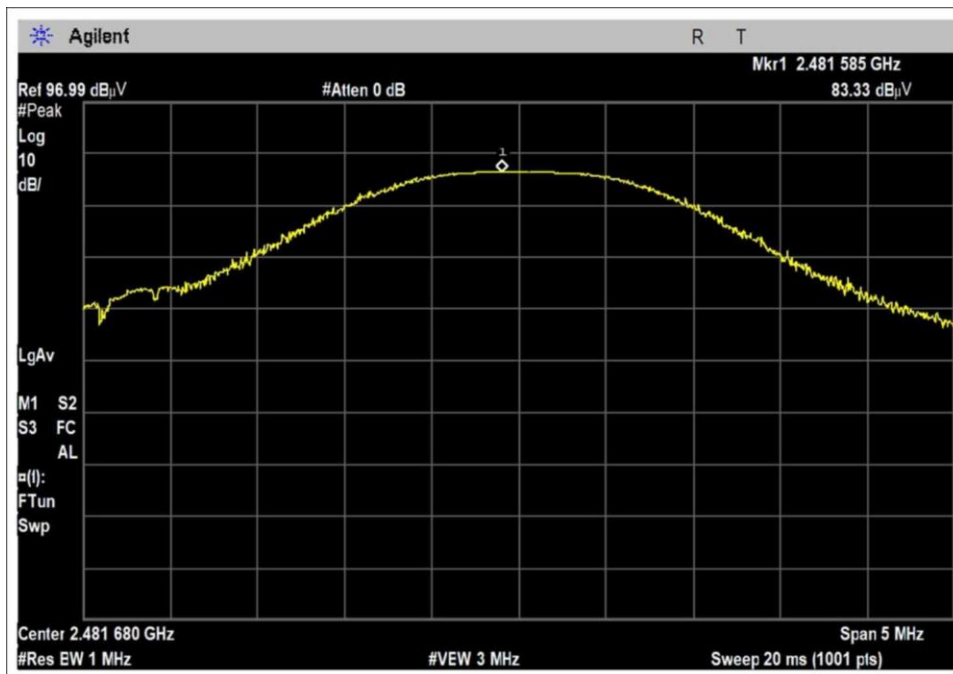

High Channel

**Test Setup / Conditions / Data**

Test Location: CKC Laboratories, Inc. • 22116 23rd Drive SE • Bothell, WA 98201 • 435-402-1717  
 Customer: **WiBotic Inc.**  
 Specification: **15.249 Carrier and Spurious Emissions (2400-2483.5 MHz Transmitter)**  
 Work Order #: **103494** Date: 5/13/2020  
 Test Type: **Maximized Emissions** Time: 09:47:19  
 Tested By: Steven Pittsford Sequence#: 34  
 Software: EMITest 5.03.12

***Equipment Tested:***

Device	Manufacturer	Model #	S/N
Configuration 1			

***Support Equipment:***

Device	Manufacturer	Model #	S/N
Configuration 1			

***Test Conditions / Notes:***

Frequency Range: 2.433-2.4817GHz  
 Frequency tested: 2.433, 2457.4 & 2.4817GHz  
 Firmware power setting: Max Power  
  
 Duty Cycle: 100%  
  
 Test Method: ANSI C63.10 (2013)  
 Test Mode: Continuously transmitting all 0 Data  
 Test Setup: EUT is located on test bench 0.8m high <1GHz and 1.5m high >1GHz .  
 EUT is investigated in X, Y & Z axis Vertical and horizontal with worst case reported.  
 A laptop is temporarily connected to change transmitter settings and removed during test.  
 EUT is powered via a fully charged battery pack.  
  
 3 x orthogonal axes investigated below 30MHz, Vertical and Horizontal axes investigated above 30MHz, worst case reported.

WiBotic Inc. WO#: 103494 Sequence#: 34 Date: 5/13/2020  
 15.249 Carrier and Spurious Emissions (2400-2483.5 MHz Transmitter) Test Distance: 3 Meters Vert

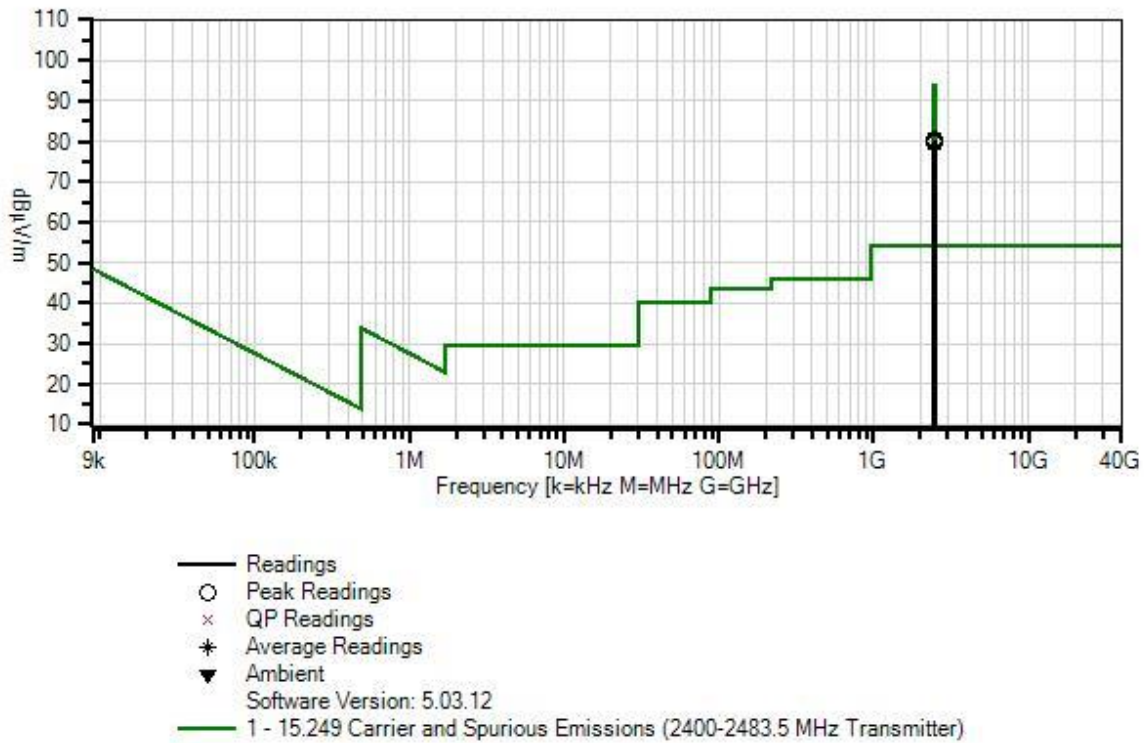

**Test Equipment:**

ID	Asset #	Description	Model	Calibration Date	Cal Due Date
T1	ANP06540	Cable	Heliacx	8/23/2019	8/23/2021
T2	AN03540	Preamp	83017A	5/13/2019	5/13/2021
T3	AN01467	Horn Antenna-ANSI C63.5 Calibration	3115	7/5/2019	7/5/2021
T4	ANP06515	Cable	Heliacx	6/29/2018	6/29/2020
T5	ANP07504	Cable	CLU40-KMKM-02.00F	1/17/2019	1/17/2021

**Measurement Data:**

Reading listed by margin.

Test Distance: 3 Meters

#	Freq	Rdng	T1	T2	T3	T4	Dist	Corr	Spec	Margin	Polar
	MHz	dBµV	T5				Table	dBµV/m	dBµV/m	dB	Ant
			dB	dB	dB	dB					
1	2481.585M	83.3	+0.6 +0.3	-34.2	+27.6	+2.7	+0.0 9	80.3	94.0 Z-Axis	-13.7	Horiz 144
2	2457.360M	83.1	+0.6 +0.3	-34.3	+27.6	+2.7	+0.0 347	80.0	94.0 Z-Axis	-14.0	Horiz 176
3	2433.175M	82.7	+0.6 +0.3	-34.3	+27.6	+2.6	+0.0	79.5	94.0 Z-Axis	-14.5	Horiz 130

**Test Setup Photo(s)**

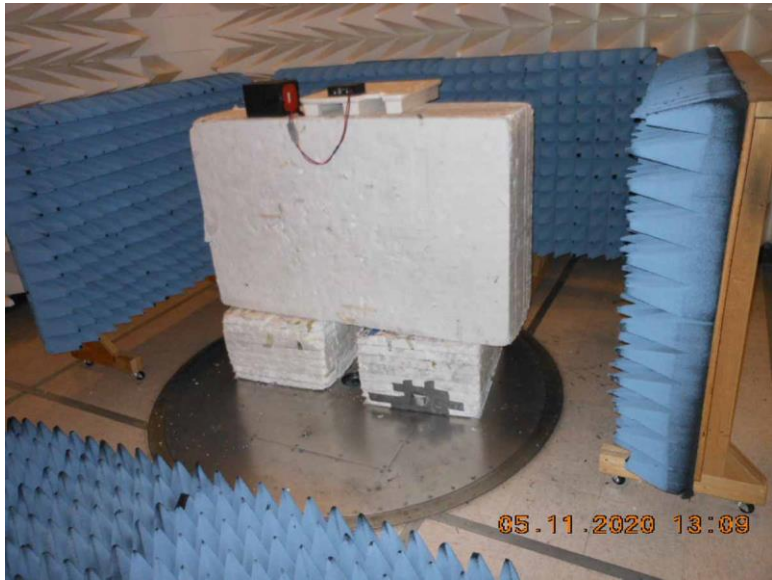

Test Setup



X Axis





Y Axis



Z Axis

## 15.249(a) Radiated Emissions and Band Edge

### Additional Testing

Testing was performed on July 1, 2020 with Configuration 2 with a 60V battery and no changes in TX power were observed.

### Test Setup / Conditions / Data

Test Location: CKC Laboratories, Inc. • 22116 23rd Drive SE • Bothell, WA 98201 • 435-402-1717  
 Customer: **WiBotic Inc.**  
 Specification: **15.249 Carrier and Spurious Emissions (2400-2483.5 MHz Transmitter)**  
 Work Order #: **103494** Date: 5/13/2020  
 Test Type: **Maximized Emissions** Time: 11:05:37  
 Tested By: Steven Pittsford Sequence#: 33  
 Software: EMITest 5.03.12

#### Equipment Tested:

Device	Manufacturer	Model #	S/N
Configuration 1			

#### Support Equipment:

Device	Manufacturer	Model #	S/N
Configuration 1			

#### Test Conditions / Notes:

Frequency Range: 9k-25GHz  
 Frequency tested: 2.433, 2457.4 & 2.4817GHz  
 Firmware power setting: Max Power

Duty Cycle: 100%

Test Method: ANSI C63.10 (2013)  
 Test Mode: Continuously transmitting all 0 Data  
 Test Setup: EUT is located on test bench 0.8m high <1GHz and 1.5m high >1GHz.  
 EUT is investigated in X, Y & Z axis Vertical and horizontal with worst case reported.  
 A laptop is temporarily connected to change transmitter settings and removed during test.  
 EUT is powered via a fully charged battery pack.  
 The manufacturer declares: All other ports are for maintenance only.

3 x orthogonal axes investigated below 30MHz, Vertical and Horizontal axes investigated above 30MHz, worst case reported.

Temperature (°C): 22-25  
 Relative Humidity (%): 30-35

WiBotic Inc. W/O#: 103494 Sequence#: 33 Date: 5/13/2020  
 15.249 Carrier and Spurious Emissions (2400-2483.5 MHz Transmitter) Test Distance: 3 Meters Vert & Horiz

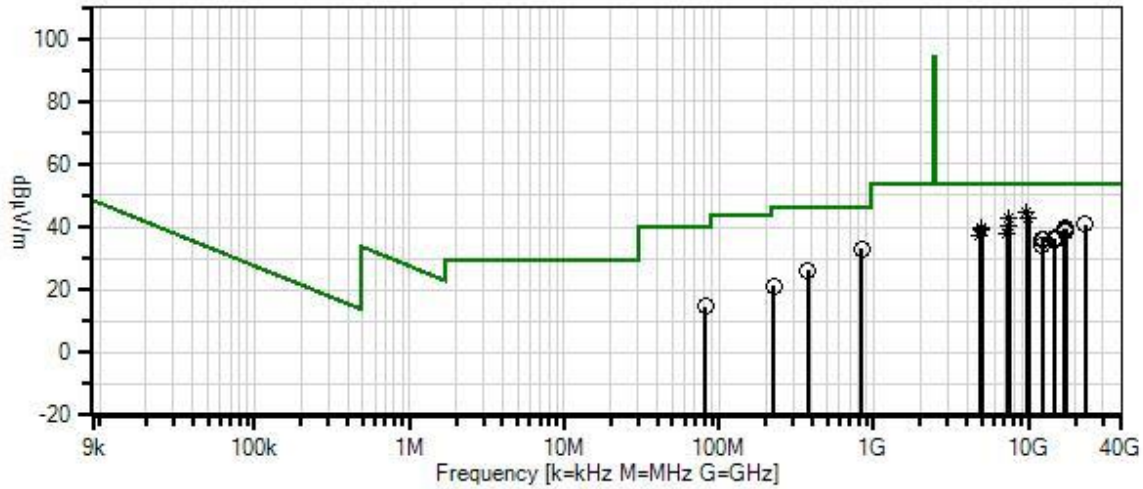

- Readings
  - Peak Readings
  - × QP Readings
  - \* Average Readings
  - ▼ Ambient
- Software Version: 5.03.12
- 1 - 15.249 Carrier and Spurious Emissions (2400-2483.5 MHz Transmitter)

**Test Equipment:**

ID	Asset #	Description	Model	Cal Date	Cal Due Date
T1	ANP06540	Cable	Heliac	8/23/2019	8/23/2021
T2	AN03540	Preamp	83017A	5/13/2019	5/13/2021
T3	AN01467	Horn Antenna-ANSI C63.5 Calibration	3115	7/5/2019	7/5/2021
T4	ANP06515	Cable	Heliac	6/29/2018	6/29/2020
T5	ANP07504	Cable	CLU40-KMKM-02.00F	1/17/2019	1/17/2021
T6	AN02741	Active Horn Antenna	AMFW-5F-12001800-20-10P	4/26/2019	4/26/2021
T7	ANP06678	Cable	32026-29801-29801-144	2/20/2020	2/20/2022
T8	ANP07211	Cable	32026-29801-29801-18	8/7/2019	8/7/2021
T9	ANP07212	Cable	32026-29801-29801-18	8/7/2019	8/7/2021
	AN02673	Spectrum Analyzer	E4446A	2/22/2019	2/22/2021
T10	ANP05305	Cable	ETSI-50T	9/6/2019	9/6/2021
T11	AN02307	Preamp	8447D	1/10/2020	1/10/2022
T12	ANP05360	Cable	RG214	2/3/2020	2/3/2022
T13	ANP06123	Attenuator	18N-6	4/5/2019	4/5/2021
T14	AN03628	Biconilog Antenna	3142E	6/11/2019	6/11/2021
T15	AN02742	Active Horn Antenna	AMFW-5F-18002650-20-10P	10/16/2018	10/16/2020
T16	AN02763-69	Waveguide	Multiple	4/28/2020	4/28/2022
T17	AN00052	Loop Antenna	6502	5/4/2020	5/4/2022

**Measurement Data:**

Reading listed by margin.

Test Distance: 3 Meters

#	Freq	Rdng	T1	T2	T3	T4	Dist	Corr	Spec	Margin	Polar
			T5	T6	T7	T8					
			T9	T10	T11	T12					
			T13	T14	T15	T16					
			T17								
	MHz	dB $\mu$ V	dB	dB	dB	dB	Table	dB $\mu$ V/m	dB $\mu$ V/m	dB	Ant
1	9730.330M Ave	32.9	+1.3 +0.4 +0.0 +0.0 +0.0	-33.9 +0.0 +0.0 +0.0 +0.0	+37.6 +0.0 +0.0 +0.0 +0.0	+6.2 +0.0 +0.0 +0.0 +0.0	+0.0	44.5	54.0 Low	-9.5	Vert 123
^	9730.330M	38.5	+1.3 +0.4 +0.0 +0.0 +0.0	-33.9 +0.0 +0.0 +0.0 +0.0	+37.6 +0.0 +0.0 +0.0 +0.0	+6.2 +0.0 +0.0 +0.0 +0.0	+0.0	50.1	54.0 Low	-3.9	Vert 143
3	9927.040M Ave	31.3	+1.3 +0.5 +0.0 +0.0 +0.0	-33.9 +0.0 +0.0 +0.0 +0.0	+37.5 +0.0 +0.0 +0.0 +0.0	+6.3 +0.0 +0.0 +0.0 +0.0	+0.0	43.0	54.0 High	-11.0	Vert 123
^	9927.040M	42.9	+1.3 +0.5 +0.0 +0.0 +0.0	-33.9 +0.0 +0.0 +0.0 +0.0	+37.5 +0.0 +0.0 +0.0 +0.0	+6.3 +0.0 +0.0 +0.0 +0.0	+0.0	54.6	54.0 High	+0.6	Vert 152

5	7445.280M Ave	33.0	+1.6 +0.3 +0.0 +0.0 +0.0	-34.7 +0.0 +0.0 +0.0	+37.2 +0.0 +0.0 +0.0	+5.5 +0.0	+0.0	42.9	54.0 High	-11.1	Vert 123
^	7445.280M	42.7	+1.6 +0.3 +0.0 +0.0 +0.0	-34.7 +0.0 +0.0 +0.0	+37.2 +0.0 +0.0 +0.0	+5.5 +0.0	+0.0	52.6	54.0 High	-1.4	Vert 152
7	9831.745M Ave	31.1	+1.3 +0.4 +0.0 +0.0 +0.0	-33.9 +0.0 +0.0 +0.0	+37.5 +0.0 +0.0 +0.0	+6.3 +0.0	+0.0	42.7	54.0 Mid	-11.3	Vert 123
^	9831.745M	42.1	+1.3 +0.4 +0.0 +0.0 +0.0	-33.9 +0.0 +0.0 +0.0	+37.5 +0.0 +0.0 +0.0	+6.3 +0.0	+0.0	53.7	54.0 Mid	-0.3	Vert 152
9	834.100M	27.5	+0.3 +0.0 +0.0 +5.8 +0.0	+0.0 +0.0 +1.4 +23.7	+0.0 +0.0 -27.6 +0.0	+0.0 +0.0 +2.0 +0.0	+0.0 360	33.1	46.0	-12.9	Vert 99
10	23250.000 M	42.4	+0.0 +0.0 +1.2 +0.0 +0.0	+0.0 +0.0 +0.0 +0.0	+0.0 +9.6 +0.0 -15.2	+0.0 +0.9 +0.0 +1.9	+0.0 360	40.8	54.0	-13.2	Vert 143
11	7374.600M Ave	30.8	+1.4 +0.4 +0.0 +0.0 +0.0	-34.6 +0.0 +0.0 +0.0	+37.0 +0.0 +0.0 +0.0	+5.4 +0.0	+0.0	40.4	54.0 Mid	-13.6	Vert 123
^	7374.600M	42.6	+1.4 +0.4 +0.0 +0.0 +0.0	-34.6 +0.0 +0.0 +0.0	+37.0 +0.0 +0.0 +0.0	+5.4 +0.0	+0.0	52.2	54.0 Mid	-1.8	Vert 152
13	4963.520M Ave	35.2	+0.9 +0.4 +0.0 +0.0 +0.0	-33.6 +0.0 +0.0 +0.0	+32.6 +0.0 +0.0 +0.0	+4.2 +0.0	+0.0 360	39.7	54.0 High	-14.3	Horiz 152
^	4963.520M	44.4	+0.9 +0.4 +0.0 +0.0 +0.0	-33.6 +0.0 +0.0 +0.0	+32.6 +0.0 +0.0 +0.0	+4.2 +0.0	+0.0	48.9	54.0 High	-5.1	Horiz 152

15	17029.185 M	39.5	+2.1 +0.0 +0.0 +0.0 +0.0	+0.0 -11.3 +0.0 +0.0 +0.0	+0.0 +0.0 +0.0 +0.0 +0.0	+9.1 +0.0 +0.0 +0.0 +0.0	+0.0	39.4	54.0 Low	-14.6	Vert 143
16	17373.775 M	40.0	+1.8 +0.0 +0.0 +0.0 +0.0	+0.0 -11.2 +0.0 +0.0 +0.0	+0.0 +0.0 +0.0 +0.0 +0.0	+8.6 +0.0 +0.0 +0.0 +0.0	+0.0	39.2	54.0 High	-14.8	Vert 143
17	4914.933M Ave	34.2	+0.9 +0.5 +0.0 +0.0 +0.0	-33.6 +0.0 +0.0 +0.0 +0.0	+32.6 +0.0 +0.0 +0.0 +0.0	+4.2 +0.0 +0.0 +0.0 +0.0	+0.0 360	38.8	54.0 Mid	-15.2	Horiz 152
^	4915.030M	43.6	+0.9 +0.5 +0.0 +0.0 +0.0	-33.6 +0.0 +0.0 +0.0 +0.0	+32.6 +0.0 +0.0 +0.0 +0.0	+4.2 +0.0 +0.0 +0.0 +0.0	+0.0	48.2	54.0 Mid	-5.8	Horiz 152
19	17199.810 M	39.6	+1.9 +0.0 +0.0 +0.0 +0.0	+0.0 -11.6 +0.0 +0.0 +0.0	+0.0 +0.0 +0.0 +0.0 +0.0	+8.8 +0.0 +0.0 +0.0 +0.0	+0.0	38.7	54.0 Mid	-15.3	Vert 143
20	7299.295M Ave	28.7	+1.2 +0.5 +0.0 +0.0 +0.0	-34.6 +0.0 +0.0 +0.0 +0.0	+36.7 +0.0 +0.0 +0.0 +0.0	+5.4 +0.0 +0.0 +0.0 +0.0	+0.0	37.9	54.0 Low	-16.1	Vert 123
^	7299.295M	38.9	+1.2 +0.5 +0.0 +0.0 +0.0	-34.6 +0.0 +0.0 +0.0 +0.0	+36.7 +0.0 +0.0 +0.0 +0.0	+5.4 +0.0 +0.0 +0.0 +0.0	+0.0	48.1	54.0 Low	-5.9	Vert 143
22	4866.170M Ave	32.6	+0.9 +0.5 +0.0 +0.0 +0.0	-33.6 +0.0 +0.0 +0.0 +0.0	+32.5 +0.0 +0.0 +0.0 +0.0	+4.1 +0.0 +0.0 +0.0 +0.0	+0.0 28	37.0	54.0 Low	-17.0	Horiz 141
^	4866.170M	43.4	+0.9 +0.5 +0.0 +0.0 +0.0	-33.6 +0.0 +0.0 +0.0 +0.0	+32.5 +0.0 +0.0 +0.0 +0.0	+4.1 +0.0 +0.0 +0.0 +0.0	+0.0 376	47.8	54.0 Low	-6.2	Horiz 141
24	14892.345 M	40.6	+1.7 +0.0 +0.0 +0.0 +0.0	+0.0 -14.4 +0.0 +0.0 +0.0	+0.0 +0.0 +0.0 +0.0 +0.0	+8.5 +0.0 +0.0 +0.0 +0.0	+0.0	36.4	54.0 High	-17.6	Vert 143

25	14745.815 M	40.9	+1.6 +0.0 +0.0 +0.0 +0.0	+0.0 -14.5 +0.0 +0.0 +0.0	+0.0 +0.0 +0.0 +0.0 +0.0	+8.3 +0.0 +0.0 +0.0 +0.0	+0.0	36.3	54.0	-17.7	Vert 143
26	14598.875 M	41.2	+1.4 +0.0 +0.0 +0.0 +0.0	+0.0 -14.7 +0.0 +0.0 +0.0	+0.0 +0.0 +0.0 +0.0 +0.0	+8.2 +0.0 +0.0 +0.0 +0.0	+0.0	36.1	54.0	-17.9	Vert 143
27	12411.205 M	40.6	+1.5 +0.0 +0.0 +0.0 +0.0	+0.0 -13.0 +0.0 +0.0 +0.0	+0.0 +0.0 +0.0 +0.0 +0.0	+7.0 +0.0 +0.0 +0.0 +0.0	+0.0	36.1	54.0	-17.9	Vert 143
28	12284.615 M	40.4	+1.4 +0.0 +0.0 +0.0 +0.0	+0.0 -12.9 +0.0 +0.0 +0.0	+0.0 +0.0 +0.0 +0.0 +0.0	+6.9 +0.0 +0.0 +0.0 +0.0	+0.0	35.8	54.0	-18.2	Vert 143
29	12163.300 M	38.7	+1.4 +0.0 +0.0 +0.0 +0.0	+0.0 -12.9 +0.0 +0.0 +0.0	+0.0 +0.0 +0.0 +0.0 +0.0	+6.9 +0.0 +0.0 +0.0 +0.0	+0.0	34.1	54.0	-19.9	Vert 143
30	377.300M	28.7	+0.2 +0.0 +0.0 +5.8 +0.0	+0.0 +0.0 +1.0 +16.6 +0.0	+0.0 +0.0 -27.5 +0.0 +0.0	+0.0 +0.0 +1.3 +0.0 +0.0	+0.0 360	26.1	46.0	-19.9	Vert 99
31	226.900M	29.6	+0.2 +0.0 +0.0 +5.8 +0.0	+0.0 +0.0 +0.7 +11.2 +0.0	+0.0 +0.0 -27.1 +0.0 +0.0	+0.0 +0.0 +0.9 +0.0 +0.0	+0.0	21.3	46.0	-24.7	Vert 99
32	81.400M	28.9	+0.1 +0.0 +0.0 +5.8 +0.0	+0.0 +0.0 +0.4 +6.8 +0.0	+0.0 +0.0 -27.8 +0.0 +0.0	+0.0 +0.0 +0.5 +0.0 +0.0	+0.0 360	14.7	40.0	-25.3	Vert 99
33	20.673M	11.1	+0.0 +0.0 +0.0 +0.0 +7.2	+0.0 +0.0 +0.0 +0.0 +0.0	+0.0 +0.5 +0.0 +0.0 +0.0	+0.0 +0.0 +0.0 +0.0 +0.0	-40.0 360	-21.2	29.5	-50.7	Para, 123

## Band Edge

### Band Edge Summary

Frequency (MHz)	Modulation	Ant. Type	Field Strength (dBuV/m @3m)	Limit (dBuV/m @3m)	Results
2400	GFSK	Integral	26.2	<54	Pass
2483.5	GFSK	Integral	40.0	<54	Pass

Test performed using operational mode with the highest output power, representing worst case.

## Band Edge Plots

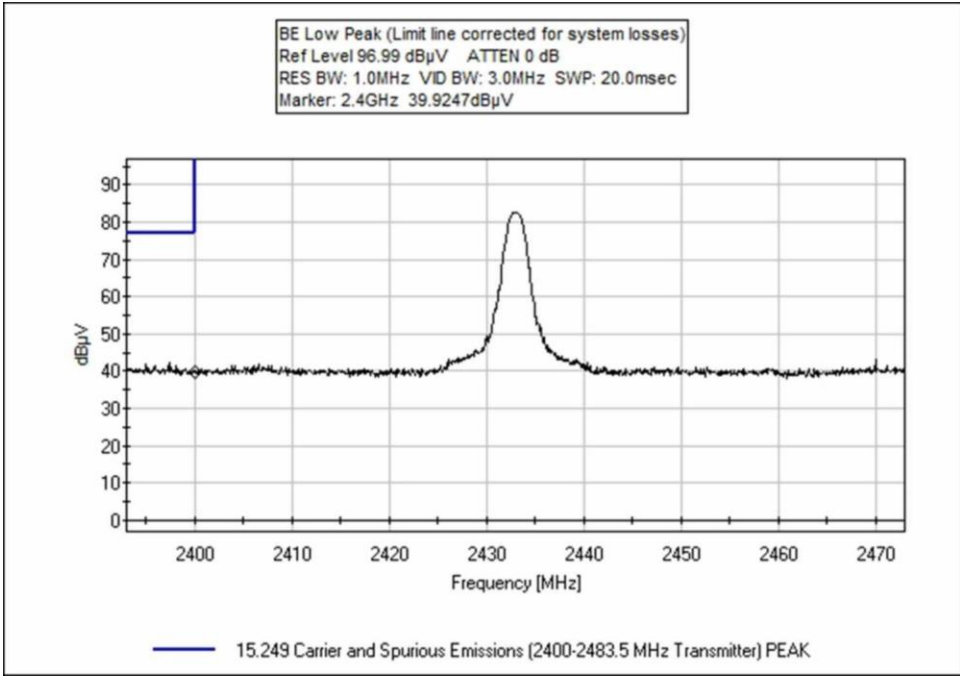



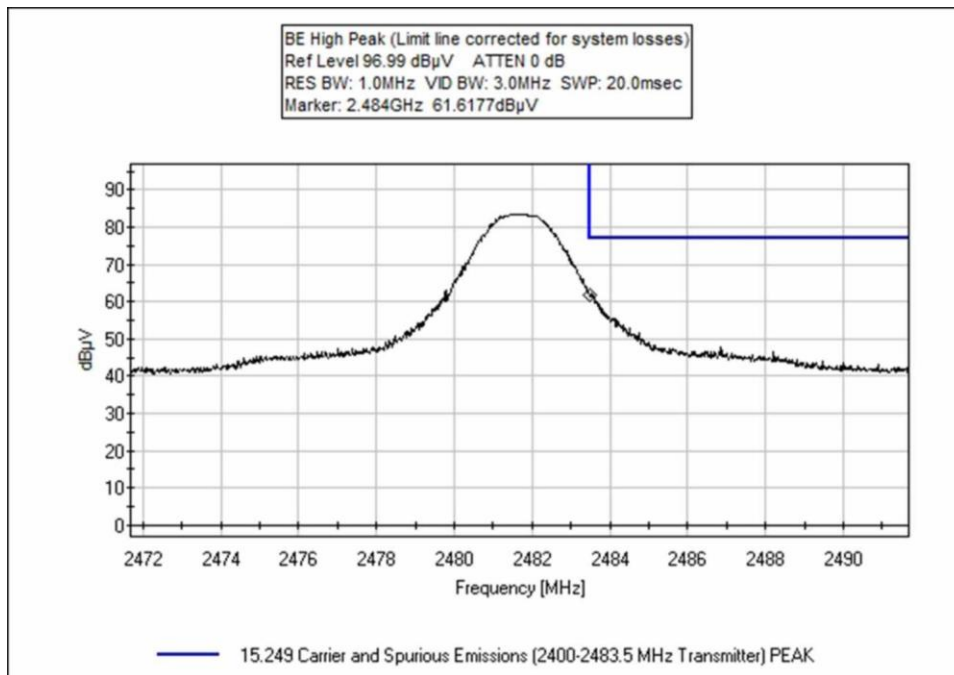
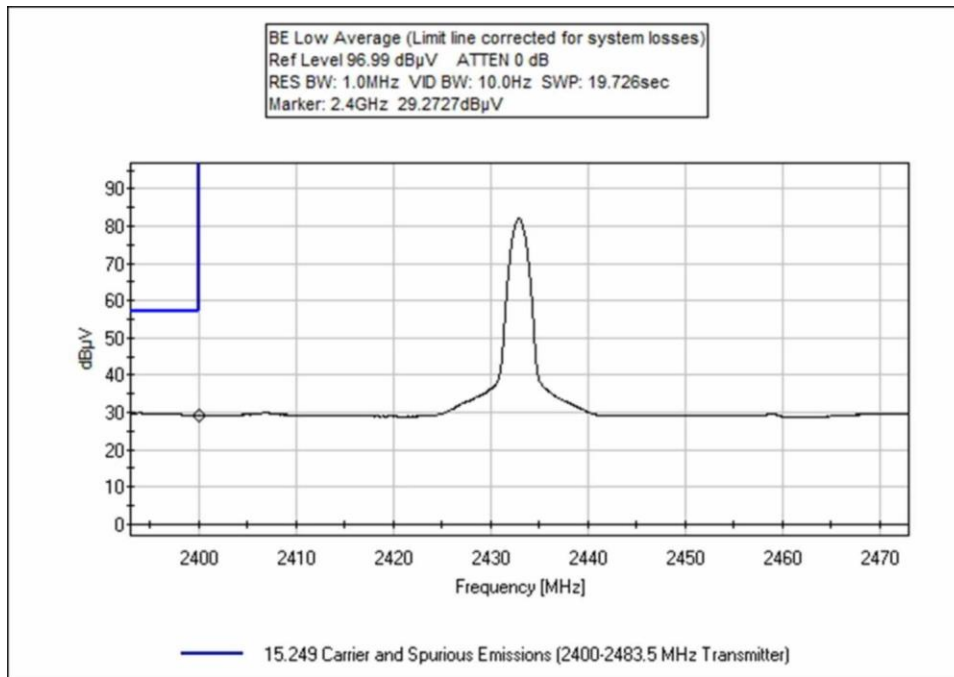

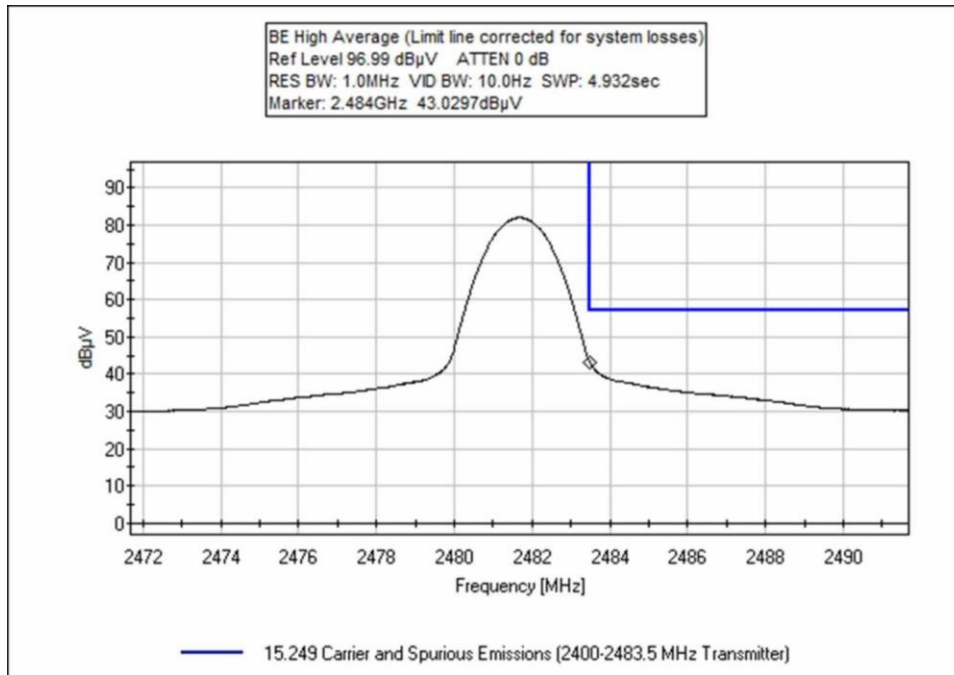

**Test Setup / Conditions / Data**

Test Location: CKC Laboratories, Inc. • 22116 23rd Drive SE • Bothell, WA 98201 • 435-402-1717  
 Customer: **WiBotic Inc.**  
 Specification: **15.249 Carrier and Spurious Emissions (2400-2483.5 MHz Transmitter)**  
 Work Order #: **103494** Date: 5/13/2020  
 Test Type: **Maximized Emissions** Time: 09:35:04  
 Tested By: Steven Pittsford Sequence#: 34  
 Software: EMITest 5.03.12

**Equipment Tested:**

Device	Manufacturer	Model #	S/N
Configuration 1			

**Support Equipment:**

Device	Manufacturer	Model #	S/N
Configuration 1			

**Test Conditions / Notes:**

Frequency Range: 2.3-2.5GHz  
 Frequency tested: 2.433 & 2.4817GHz  
 Firmware power setting: Max Power  
  
 Duty Cycle: 100%  
  
 Test Method: ANSI C63.10 (2013)  
 Test Mode: Continuously transmitting all 0 Data  
 Test Setup: EUT is located on test bench 0.8m high <1GHz and 1.5m high >1GHz .  
 EUT is investigated in X, Y & Z axis Vertical and horizontal with worst case reported.  
 A laptop is temporarily connected to change transmitter settings and removed during test.  
 EUT is powered via a fully charged battery pack.  
  
 3 x orthogonal axes investigated below 30MHz, Vertical and Horizontal axes investigated above 30MHz, worst case reported.  
  
 Temperature (°C): 22-25  
 Relative Humidity (%): 30-35

**Test Equipment:**

ID	Asset #	Description	Model	Calibration Date	Cal Due Date
T1	ANP06540	Cable	Heliacx	8/23/2019	8/23/2021
T2	AN03540	Preamp	83017A	5/13/2019	5/13/2021
T3	AN01467	Horn Antenna-ANSI C63.5 Calibration	3115	7/5/2019	7/5/2021
T4	ANP06515	Cable	Heliacx	6/29/2018	6/29/2020
T5	ANP07504	Cable	CLU40-KMKM-02.00F	1/17/2019	1/17/2021

**Measurement Data:** Reading listed by margin. Test Distance: 3 Meters

#	Freq MHz	Rdng dB $\mu$ V	T1 T5 dB	T2 dB	T3 dB	T4 dB	Dist Table	Corr dB $\mu$ V/m	Spec dB $\mu$ V/m	Margin dB	Polar Ant
1	2483.500M Ave	43.0	+0.6 +0.3	-34.2	+27.6	+2.7	+0.0 9	40.0	54.0	-14.0	Vert 144
^	2483.500M	60.8	+0.6 +0.3	-34.2	+27.6	+2.7	+0.0 9	57.8	54.0	+3.8	Vert 144
3	2400.000M	39.9	+0.6 +0.3	-34.3	+27.7	+2.6	+0.0 336	36.8	54.0	-17.2	Vert 158
4	2400.000M	29.3	+0.6 +0.3	-34.3	+27.7	+2.6	+0.0 336	26.2	54.0	-27.8	Vert 158

**Test Setup Photo(s)**



Below 1GHz

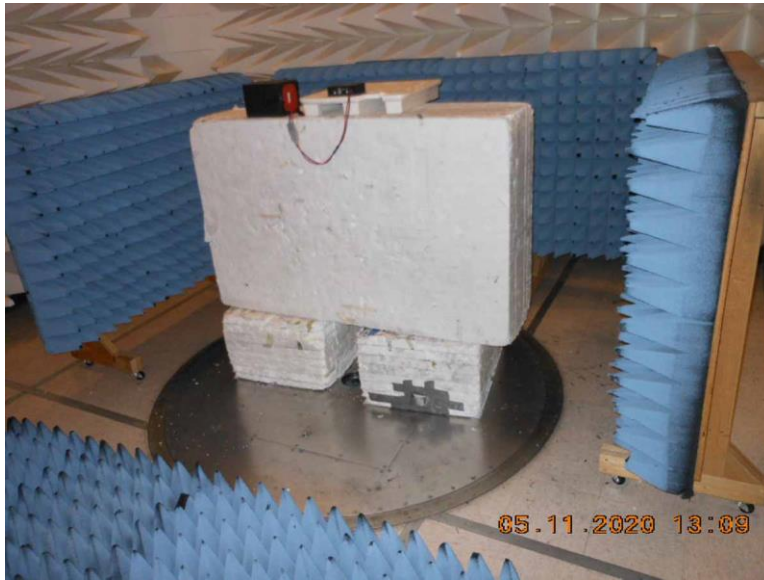

Above 1GHz



X Axis



Y Axis



Z Axis



Below 1GHz with Antenna Port Filled



Below 1GHz with Antenna Port Filled



Above 1GHz with Antenna Port Filled



Above 1GHz with Antenna Port Filled



## Appendix A: Manufacturer Declaration

The following models have been tested by CKC Laboratories:

### **OC-251-12-ST**

Since the time of testing, the manufacturer has chosen to use the following model names in its place. The manufacturer declares that any differences between the names does not affect their EMC characteristics and therefore meets the level of testing equivalent to the tested model name:

### **OC-251**

## SUPPLEMENTAL INFORMATION

### Measurement Uncertainty

Uncertainty Value	Parameter
4.73 dB	Radiated Emissions
3.34 dB	Mains Conducted Emissions
3.30 dB	Disturbance Power

Uncertainties reported are worst case for all CKC Laboratories’ sites and represent expanded uncertainties expressed at approximately the 95% confidence level using a coverage factor of k=2. Compliance is deemed to occur provided measurements are below the specified limits.

### Emissions Test Details

**TESTING PARAMETERS**

Unless otherwise indicated, the following configuration parameters are used for equipment setup: The cables were routed consistent with the typical application by varying the configuration of the test sample. Interface cables were connected to the available ports of the test unit. The effect of varying the position of the cables was investigated to find the configuration that produced maximum emissions. Cables were of the type and length specified in the individual requirements. The length of cable that produced maximum emissions was selected.

The equipment under test (EUT) was set up in a manner that represented its normal use, as shown in the setup photographs. Any special conditions required for the EUT to operate normally are identified in the comments that accompany the emissions tables.

The emissions data was taken with a spectrum analyzer or receiver. Incorporating the applicable correction factors for distance, antenna, cable loss and amplifier gain, the data was reduced as shown in the table below. The corrected data was then compared to the applicable emission limits. Preliminary and final measurements were taken in order to ensure that all emissions from the EUT were found and maximized.

**CORRECTION FACTORS**

The basic spectrum analyzer reading was converted using correction factors as shown in the highest emissions readings in the tables. For radiated emissions in dBμV/m, the spectrum analyzer reading in dBμV was corrected by using the following formula. This reading was then compared to the applicable specification limit. Individual measurements were compared with the displayed limit value in the margin column. The margin was calculated based on subtracting the limit value from the corrected measurement value; a positive margin represents a measurement exceeding the limit, while a negative margin represents a measurement less than the limit.

SAMPLE CALCULATIONS		
	Meter reading	(dBμV)
+	Antenna Factor	(dB/m)
+	Cable Loss	(dB)
-	Distance Correction	(dB)
-	Preamplifier Gain	(dB)
=	Corrected Reading	(dBμV/m)

**TEST INSTRUMENTATION AND ANALYZER SETTINGS**

The test instrumentation and equipment listed were used to collect the emissions data. A spectrum analyzer or receiver was used for all measurements. Unless otherwise specified, the following table shows the measuring equipment bandwidth settings that were used in designated frequency bands. For testing emissions, an appropriate reference level and a vertical scale size of 10 dB per division were used.

MEASURING EQUIPMENT BANDWIDTH SETTINGS PER FREQUENCY RANGE			
TEST	BEGINNING FREQUENCY	ENDING FREQUENCY	BANDWIDTH SETTING
CONDUCTED EMISSIONS	150 kHz	30 MHz	9 kHz
RADIATED EMISSIONS	9 kHz	150 kHz	200 Hz
RADIATED EMISSIONS	150 kHz	30 MHz	9 kHz
RADIATED EMISSIONS	30 MHz	1000 MHz	120 kHz
RADIATED EMISSIONS	1000 MHz	>1 GHz	1 MHz

**SPECTRUM ANALYZER/RECEIVER DETECTOR FUNCTIONS**

The notes that accompany the measurements contained in the emissions tables indicate the type of detector function used to obtain the given readings. Unless otherwise noted, all readings were made in the "positive peak" detector mode. Whenever a "quasi-peak" or "average" reading was recorded, the measurement was annotated with a "QP" or an "Ave" on the appropriate rows of the data sheets. In cases where quasi-peak or average limits were employed and data exists for multiple measurement types for the same frequency then the peak measurement was retained in the report for reference, however the numbering for the affected row was removed and an arrow or caret ("^") was placed in the far left-hand column indicating that the row above takes precedence for comparison to the limit. The following paragraphs describe in more detail the detector functions and when they were used to obtain the emissions data.

**Peak**

In this mode, the spectrum analyzer or receiver recorded all emissions at their peak value as the frequency band selected was scanned. By combining this function with another feature called "peak hold," the measurement device had the ability to measure intermittent or low duty cycle transient emission peak levels. In this mode the measuring device made a slow scan across the frequency band selected and measured the peak emission value found at each frequency across the band.

**Quasi-Peak**

Quasi-peak measurements were taken using the quasi-peak detector when the true peak values exceeded or were within 2 dB of a quasi-peak specification limit. Additional QP measurements may have been taken at the discretion of the operator.

**Average**

Average measurements were taken using the average detector when the true peak values exceeded or were within 2 dB of an average specification limit. Additional average measurements may have been taken at the discretion of the operator. If the specification or test procedure requires trace averaging, then the averaging was performed using 100 samples or as required by the specification. All other average measurements are performed using video bandwidth averaging. To make these measurements, the test engineer reduces the video bandwidth on the measuring device until the modulation of the signal is filtered out. At this point, the measuring device is set into the linear mode and the scan time is reduced.