

# BoT-nLE521

Specification

CONFIDENTIAL INFORMATION

## List of Contents

1. General.....	3
1.1 Overview .....	3
1.2 Block Diagram .....	3
1.3 Features .....	4
1.4 Application .....	4
1.5 Pin Configuration .....	5
1.6 PIN Description .....	6
1.7 Dimensions .....	7
1.8 Land Pattern .....	8
2. Characteristics.....	9
2.1 Electrical Characteristics .....	9
2.2 RF Characteristics .....	11
3.1 Regulator .....	12
3.2 32.768KHz Crystal Oscillator .....	13
4. Application Schematic.....	15
5. Antenna .....	16
5.1 Antenna Layout Guide .....	16
6. Certification .....	17
6.1 FCC Statement.....	17

### 1. General

#### 1.1 Overview

The BoT-nLE521 module is a cost-effective, low-power, true system-on-chip (SoC) for Bluetooth Smart (Bluetooth low energy) applications. It enables robust BLE master or slave nodes to be built with very low total bill-of-material costs. BoT-nLE521 combines an excellent RF transceiver with an industry-standard enhanced Cortex-M4 CPU, in-system programmable flash memory, 24kB RAM, and many other powerful supporting features and peripherals. The BoT-nLE521 is suitable for systems where very low power

consumption is required. Very low-power sleep modes are available. Short transition times between operating modes further enable low power consumption.

#### 1.2 Block Diagram

### 1.3 Features

- Built in Antenna Bluetooth Smart (Bluetooth Low Energy) Module.
- ARM® Cortex®-M4 32-bit processor with FPU, 64 MHz
- Memory: 192 kB Flash / 24 kB RAM
- RF Output Power: MAX +4 dBm (-20 ~ 4 dBm)
- RF Receive Sensitivity: -96 dBm
- Type 2 near field communication (NFC-A) tag with wakeup-on-field and touch to-pair capabilities
- Fully automatic LDO and DC/DC regulator system (Used LDO by Default)
- Temperature Sensor
- UART (CTS/RTS) with EasyDMA, SPI, and I2C data interfaces.
- 12-Bit 200 ksp/s ADC with - 8 configurable channels with programmable gain
- Size: 15 mm x 8 mm x 1.8 mm
- Operating Voltage: 1.7V to 3.6V
- Operating Temperature: -40 to +85°C
- RoHS compliant

### 1.4 Application

- Computer peripherals and I/O devices
  - Mouse
  - Keyboard
  - Multi-touch trackpad
- Interactive entertainment devices
- Remote control
  - Gaming controller
- Beacons
- Personal Area Networks
  - Health/fitness sensor and monitor devices
  - Medical devices
  - Key-fobs + wrist watches
- Remote control toys

### 1.5 Pin Configuration

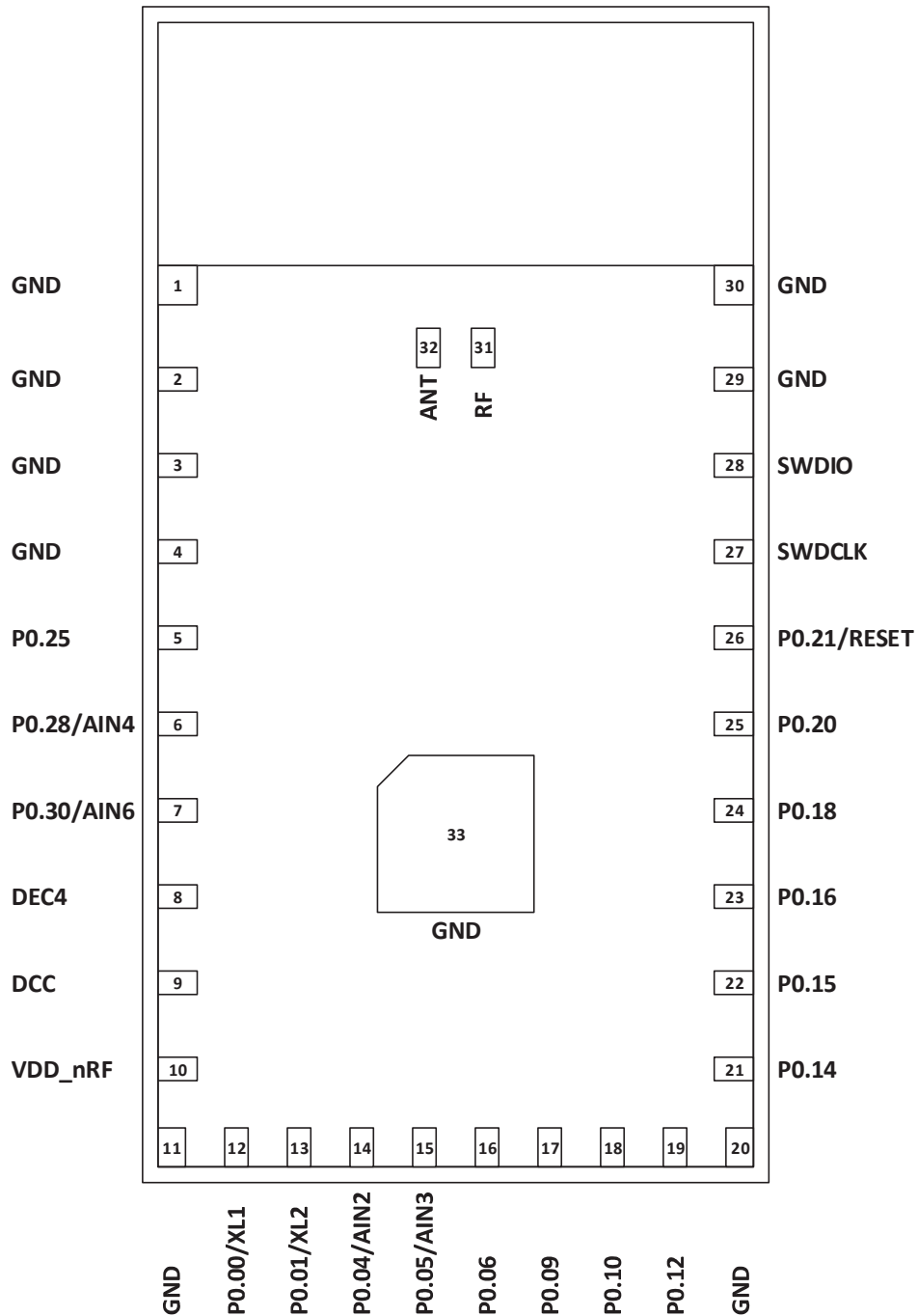

TOP VIEW

### 1.6 PIN Description

Pin No.	Pin Name	Pin Function	Description
01	GND	GROUND	Ground Pin.
02	GND	GROUND	Ground Pin.
03	GND	GROUND	Ground Pin.
04	GND	GROUND	Ground Pin.
05	P0.25	DIGITAL I/O	General purpose I/O pin.
06	P0.28	DIGITAL I/O	General purpose I/O pin.
	AIN4	ANALOG INPUT	SAADC/COMP input
07	P0.30	DIGITAL I/O	General purpose I/O pin.
	AIN6	ANALOG INPUT	COMP input
08	DEC4	POWER	1.3 V regulator supply decoupling Input from DC/DC converter. Output from 1.3 V LDO
09	DCC	POWER	DC/DC regulator output
10	VDD_nRF	POWER	Power supply pin.
11	GND	GROUND	Ground Pin.
12	P0.00	DIGITAL I/O	General purpose I/O pin.
	XL1	ANALOG INPUT	Connection for 32.768 kHz crystal (LFXO)
13	P0.01	DIGITAL I/O	General purpose I/O pin.
	XL2	ANALOG INPUT	Connection for 32.768 kHz crystal (LFXO)
14	P0.04	DIGITAL I/O	General purpose I/O pin.
	AIN2	ANALOG INPUT	SAADC/COMP input
15	P0.05	DIGITAL I/O	General purpose I/O pin.
	AIN3	ANALOG INPUT	SAADC/COMP input
16	P0.06	DIGITAL I/O	General purpose I/O pin.
	RXD	DIGITAL INPUT	UART RXD
17	P0.09	DIGITAL I/O	General purpose I/O pin.
	TXD	DIGITAL OUTPUT	UART TXD
18	P0.10	DIGITAL I/O	General purpose I/O pin.
	CTS	DIGITAL OUTPUT	UART CTS
19	P0.12	DIGITAL I/O	General purpose I/O pin.
	RTS	DIGITAL INPUT	UART RTS
20	GND	GROUND	Ground Pin.
21	P0.14	DIGITAL I/O	General purpose I/O pin.
22	P0.15	DIGITAL I/O	General purpose I/O pin.
23	P0.16	DIGITAL I/O	General purpose I/O pin.
24	P0.18	DIGITAL I/O	General purpose I/O pin.
25	P0.20	DIGITAL I/O	General purpose I/O pin.
26	P0.21	DIGITAL I/O	General purpose I/O pin.
	RESET	nRESET	Configurable as system RESET pin.
27	SWDCLK	DIGITAL INPUT	Serial Wire Debug clock input for debug and programming
28	SWDIO	DIGITAL I/O	Serial Wire Debug I/O for debug and programming
29	GND	GROUND	Ground Pin.
30	GND	GROUND	Ground Pin.
31	RF	RF IN / OUT PORT	Bluetooth 50Ω transmitter output / receiver input
32	ANT	INTERNAL ANTENNA IN / OUT	Internal antenna. It should be connected to Pin 32 RF for normal operation.
33	GND	GROUND	Ground Pin.

1.7 Dimensions

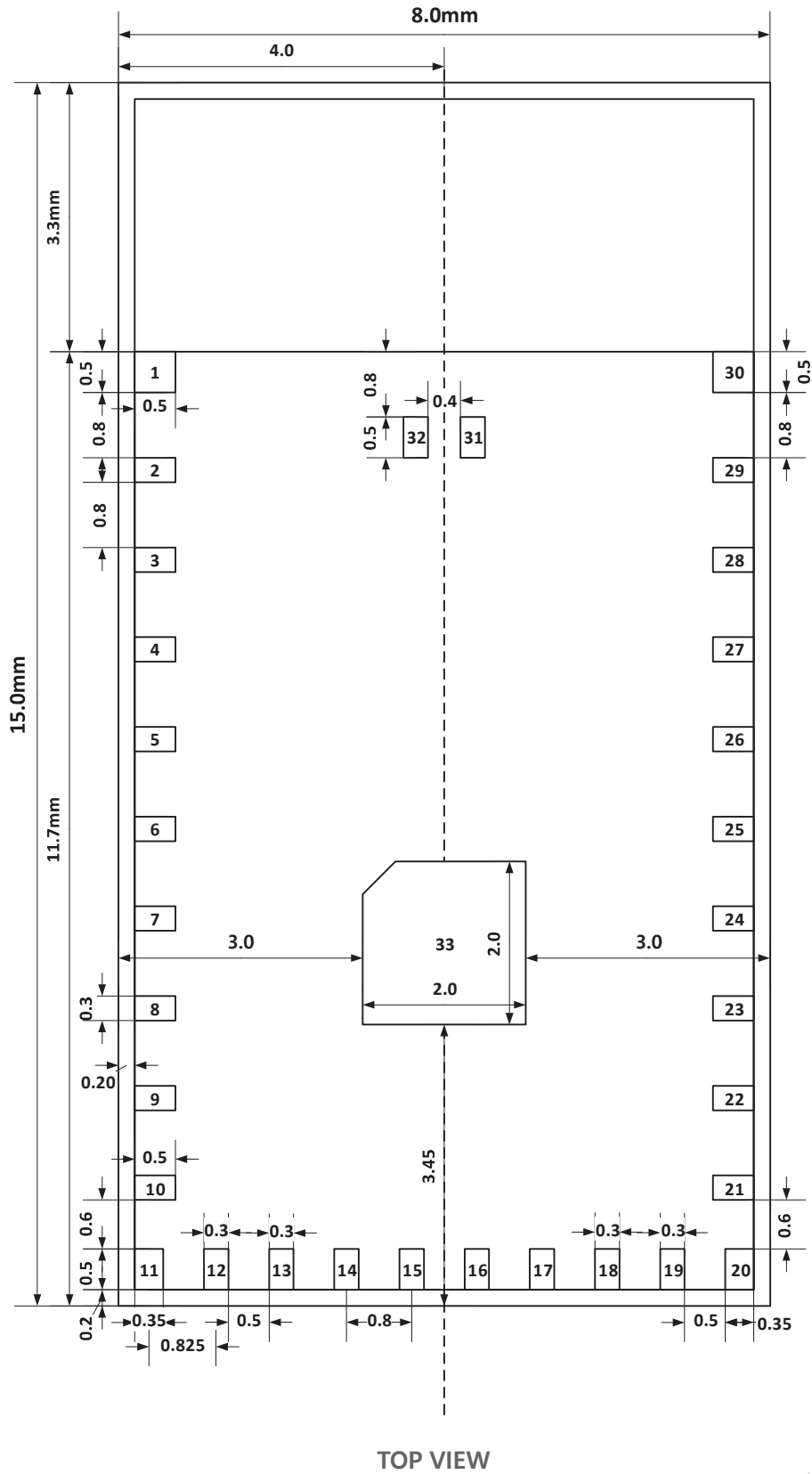

1.8 Land Pattern

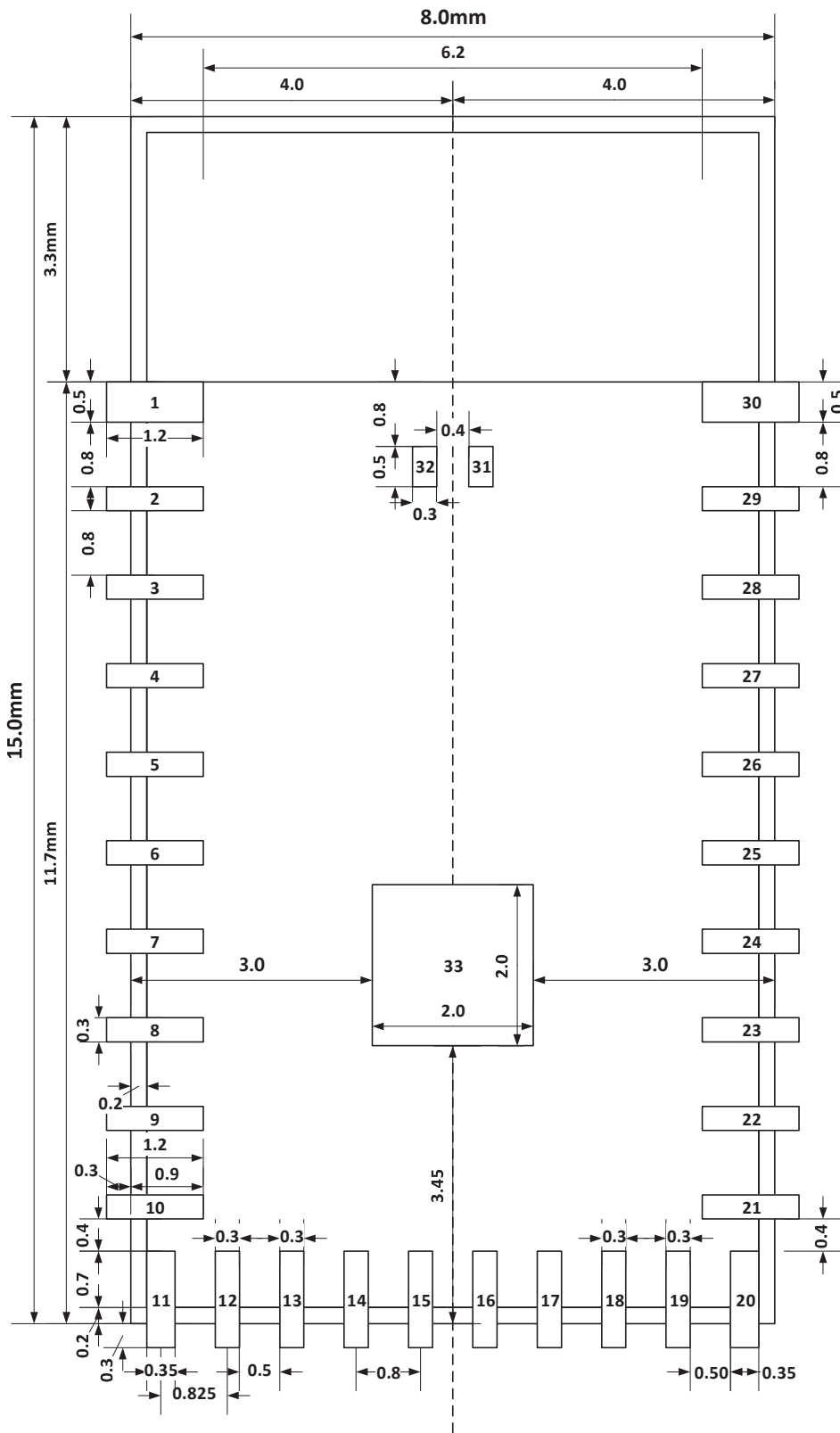

Land Pattern (TOP VIEW)



## 2. Characteristics

### 2.1 Electrical Characteristics

#### ■ Absolute Maximum Ratings

Symbol	Parameter	Min.	Max.	Units
VDD		-0.3	+3.9	V
GND			0	V
$V_{I/O}, VDD \leq 3.6V$		-0.3	VDD + 0.3	V
$V_{I/O}, VDD > 3.6V$		-0.3	+3.9	V
Storage temperature		-40	+125	°C
Radio	RF Input Level		10	dBm
MSL	Moisture Sensitivity Level	2		
ESD HBM	Human Body Model		4	kV
ESD CDM	Charged Device Model		1000	V
Endurance	Flash Memory Endurance	10000		write/erase cycles
Retention	Flash Memory Retention	10 years		At 40 °C

#### ■ Recommended Operating Conditions

Symbol	Parameter	Min.	Typ.	Max.	Units
VDD	LDO Regulator Operation (Default Mode)	1.7	3.0	3.6	V
VDD	DC/DC Regulator Operation	2.1	3.0	3.6	V
$t_r$ VDD	Supply rise time (0V to 1.7V)			60	ms
TA	Operation temperature	-40	25	85	°C

#### ■ DC Characteristics

Symbol	Parameter (condition)	Min.	Typ.	Max.	Units
$V_{IH}$	Input high voltage	0.7 X VDD		VDD	V
$V_{IL}$	Input low voltage	VSS		0.3 X VDD	V
$V_{OH,SD}$	Output high voltage, standard drive, 0.5 mA, VDD ≥ 1.7	VDD-0.4		VDD	V
$V_{OH,HDH}$	Output high voltage, high drive, 5 mA, VDD ≥ 2.7 V	VDD-0.4		VDD	V
$V_{OH,HDL}$	Output high voltage, high drive, 3 mA, VDD ≥ 1.7 V	VDD-0.4		VDD	V
$V_{OL,SD}$	Output low voltage, standard drive, 0.5 mA, VDD ≥ 1.7	VSS		VSS + 0.4	V
$V_{OL,HDH}$	Output low voltage, high drive, 5 mA, VDD ≥ 2.7 V	VSS		VSS + 0.4	V

V <sub>OL,HDL</sub>	Output low voltage, high drive, 3 mA, VDD ≥ 1.7 V	VSS		VSS +0.4	V
R <sub>PU</sub>	Pull-up resistance	11	13	16	kΩ
R <sub>PD</sub>	Pull-down resistance	11	13	16	kΩ
I <sub>TX,+4dBm,DCDC</sub>	TX only run current (DCDC, 3V) P <sub>RF</sub> =+4 dBm		7.0		mA
I <sub>TX,+4dBm</sub>	TX only run current P <sub>RF</sub> =+4 dBm		15.4		mA
I <sub>RX,1M,DCDC</sub>	RX only run current (DCDC, 3V) 1Msps		4.6		mA
I <sub>RX,1M</sub>	RX only run current 1Msps		10.0		mA
I <sub>RX,2M,DCDC</sub>	RX only run current (DCDC, 3V) 2Msps		5.2		mA
I <sub>RX,2M</sub>	RX only run current 2Msps		11.2		mA
I <sub>ON_RAMOFF_EVENT</sub>	System ON, No RAM retention, Wake on any event		0.6		μA
I <sub>ON_RAMON_EVENT</sub>	System ON, Full 24 kB RAM retention, Wake on any event		0.8		μA
I <sub>ON_RAMON_POF</sub>	System ON, Full 24 kB RAM retention, Wake on any event, Power fail comparator enabled		0.8		μA
I <sub>ON_RAMON_GPIOTE</sub>	System ON, Full 24 kB RAM retention, Wake on GPIOTE input (Event mode)		3.3		μA
I <sub>ON_RAMON_GPIOTEPORT</sub>	System ON, Full 24 kB RAM retention, Wake on GPIOTE PORT event		0.8		μA
I <sub>ON_RAMON_RTC</sub>	System ON, Full 24 kB RAM retention, Wake on RTC (running from LFRC clock)		1.5		μA
I <sub>OFF_RAMOFF_RESET</sub>	System OFF, No RAM retention, Wake on reset		0.3		μA
I <sub>OFF_RAMON_RESET</sub>	System OFF, Full 24 kB RAM retention, Wake on reset		0.5		μA

### 2.2 RF Characteristics

Symbol	Description	Min.	Typ.	Max.	Units
$f_{OP}$	Operating frequencies	2402		2480	MHz
$f_{PLL,PROG,RES}$	PLL programming resolution		2		kHz
$f_{PLL,CH,SP}$	PLL channel spacing		1		MHz
$f_{DELTA,BLE,1M}$	Frequency deviation @ BLE 1Msps		$\pm 250$		kHz
$f_{DELTA,BLE,2M}$	Frequency deviation @ BLE 2Msps		$\pm 500$		kHz
$P_{RF}$	Maximum output power		0	4	dBm
$P_{RFC}$	RF power control range		24		dB
$P_{RFCR}$	RF power accuracy			$\pm 4$	dB
$P_{RF1,1}$	1st Adjacent Channel Transmit Power 1 MHz (1 Msps)		-25		dBc
$P_{RF2,1}$	2nd Adjacent Channel Transmit Power 2 MHz (1 Msps)		-50		dBc
$P_{RF1,2}$	1st Adjacent Channel Transmit Power 2 MHz (2 Msps)		-25		dBc
$P_{RF2,2}$	2nd Adjacent Channel Transmit Power 4 MHz (2 Msps)		-50		dBc
$P_{RX,MAX}$	Maximum received signal strength at < 0.1% PER		0		dBm
$P_{SENS,IT,SP,1M,BLE}$	Sensitivity, 1Msps BLE ideal transmitter, $\leq 37$ bytes BER=1E-3		-96		dBm
$P_{SENS,IT,SP,2M,BLE}$	Sensitivity, 2Msps BLE ideal transmitter, $\leq 37$ bytes		-93		dBm
$RSSI_{ACC}$	RSSI Accuracy Valid range -90 to -20 dBm		$\pm 2$		dB
$RSSI_{RESOLUTION}$	RSSI resolution		1		dB
$RSSI_{PERIOD}$	Sample period		8		us

### 3. Terminal Description

#### 3.1 Regulator

The following internal power regulator alternatives are supported:

- Internal LDO regulator
- Internal DC/DC regulator

The LDO is the default regulator.

Using the DC/DC regulator will reduce current consumption compared to when using the LDO regulator, but the DC/DC regulator requires an external LC filter to be connected, as shown in Figure.

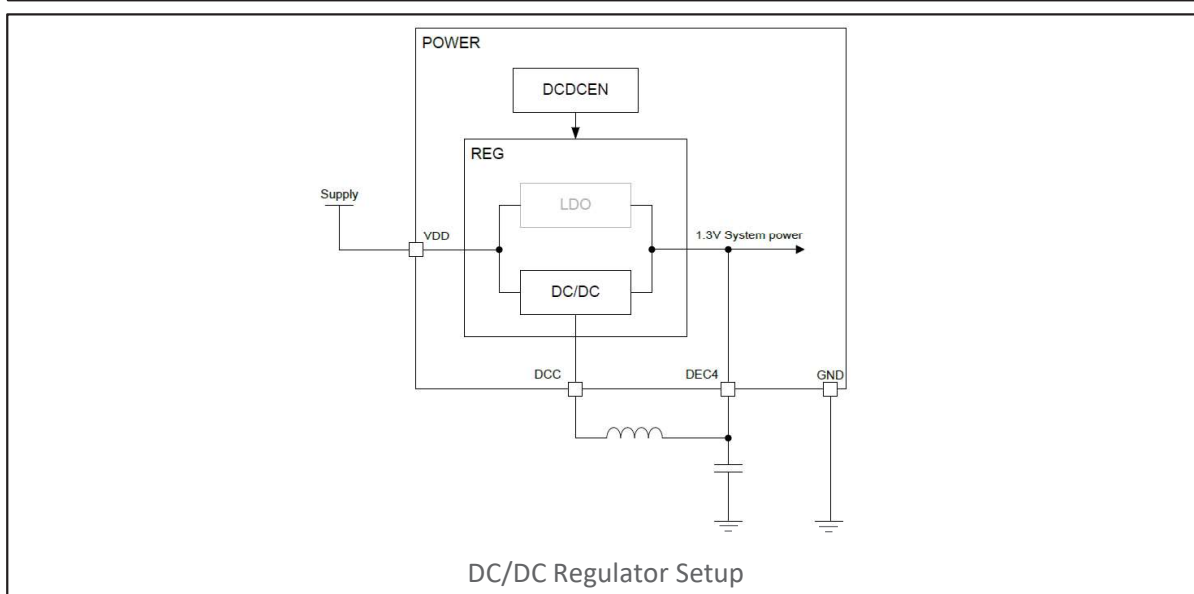
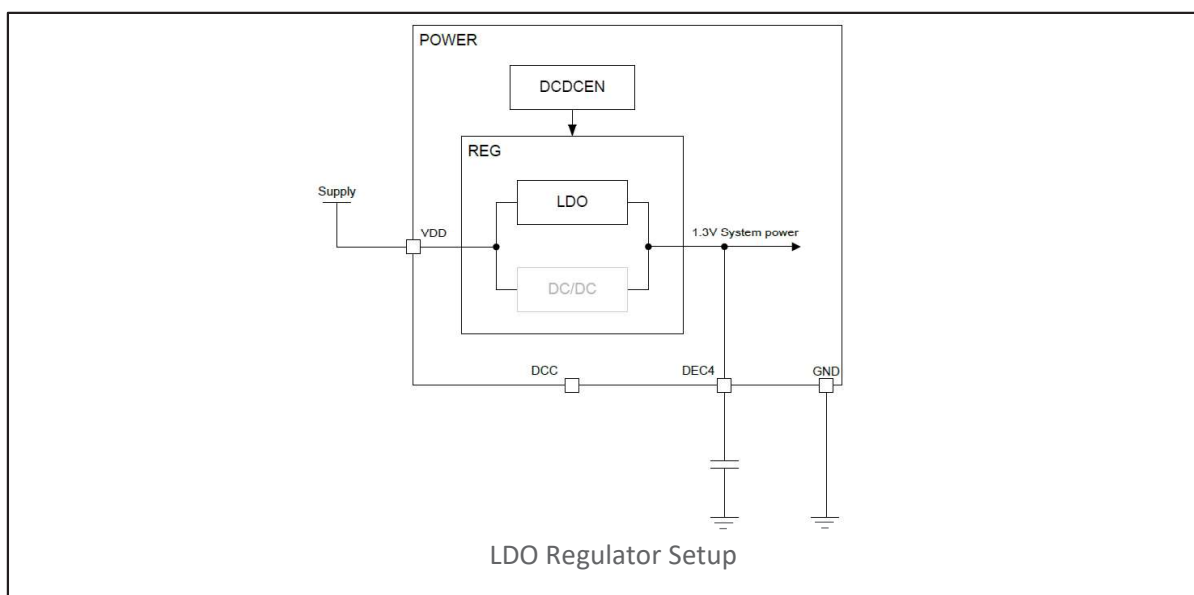

### 3.2 32.768KHz Crystal Oscillator

The BoT-nLE521 external 32.768KHz Crystal does not required for BLE mode

If you choose to use an internal 32.768kHz oscillator, an average of 10uA of current is consumed compared to an external crystal.

The ANT specification requires  $\pm 50$ ppm accuracy for a 32.768kHz clock. The internal 32.768kHz oscillator may not meet specifications.

BoT-nLE521 F/W does not yet support ANT Mode.

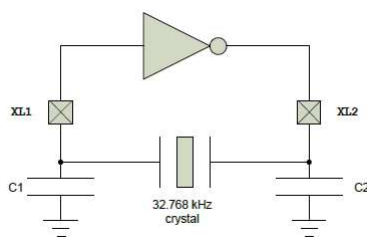
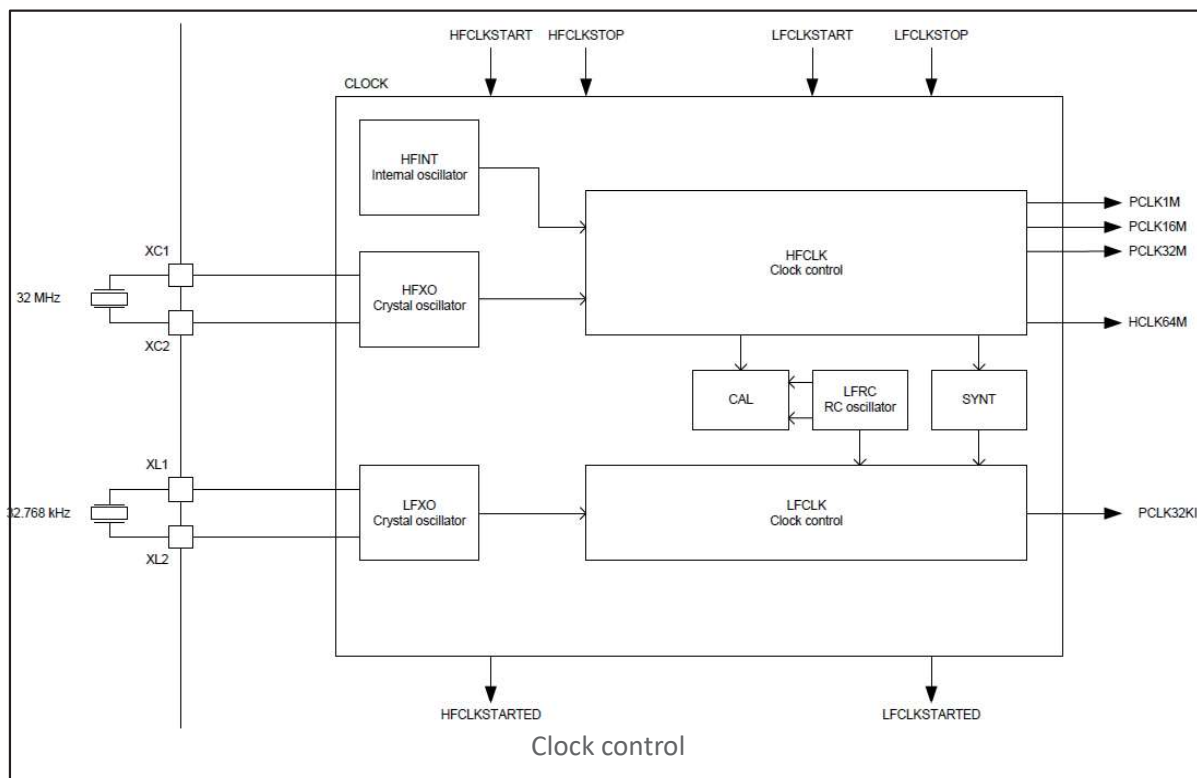

Circuit diagram of the 32.768 kHz crystal oscillator

The load capacitance (CL) is the total capacitance seen by the crystal across its terminals and is given by:

$$C_L = \frac{(C1' \cdot C2')}{(C1' + C2')}$$

$$C1' = C1 + C_{pcb1} + C_{pin}$$

$$C2' = C2 + C_{pcb2} + C_{pin}$$

C1 and C2 are ceramic SMD capacitors connected between each crystal terminal and ground. Cpcb1 and Cpcb2 are stray capacitances on the PCB.

▪ 32.768 kHz RC oscillator (LFRC)

Symbol	Description	Min.	Typ.	Max.	Units
$f_{\text{NOM\_LFRC}}$	Nominal frequency		32.768		kHz
$f_{\text{TOL\_LFRC}}$	Frequency tolerance		$\pm 2$		%
$f_{\text{TOL\_CAL\_LFRC}}$	Frequency tolerance for LFRC after calibration		$\pm 500$		ppm

▪ 32.768 kHz crystal oscillator (LFXO)

Symbol	Description	Min.	Typ.	Max.	Units
$f_{\text{NOM\_LFXO}}$	Crystal frequency		32.768		kHz
$f_{\text{TOL\_LFXO\_BLE}}$	Frequency tolerance requirement for BLE stack		$\pm 250$		ppm
$f_{\text{TOL\_LFXO\_ANT}}$	Frequency tolerance requirement for ANT stack		$\pm 50$		ppm
$C_{\text{L\_LFXO}}$	Load capacitance			12.5	pF
$C_{\text{O\_LFXO}}$	Shunt capacitance			2	pF
$R_{\text{S\_LFXO}}$	Equivalent series resistance			100	kohm
$P_{\text{D\_LFXO}}$	Drive level			1	uW
$C_{\text{pin}}$	Input capacitance on XL1 and XL2 pads		4		pF

### 4. Application Schematic

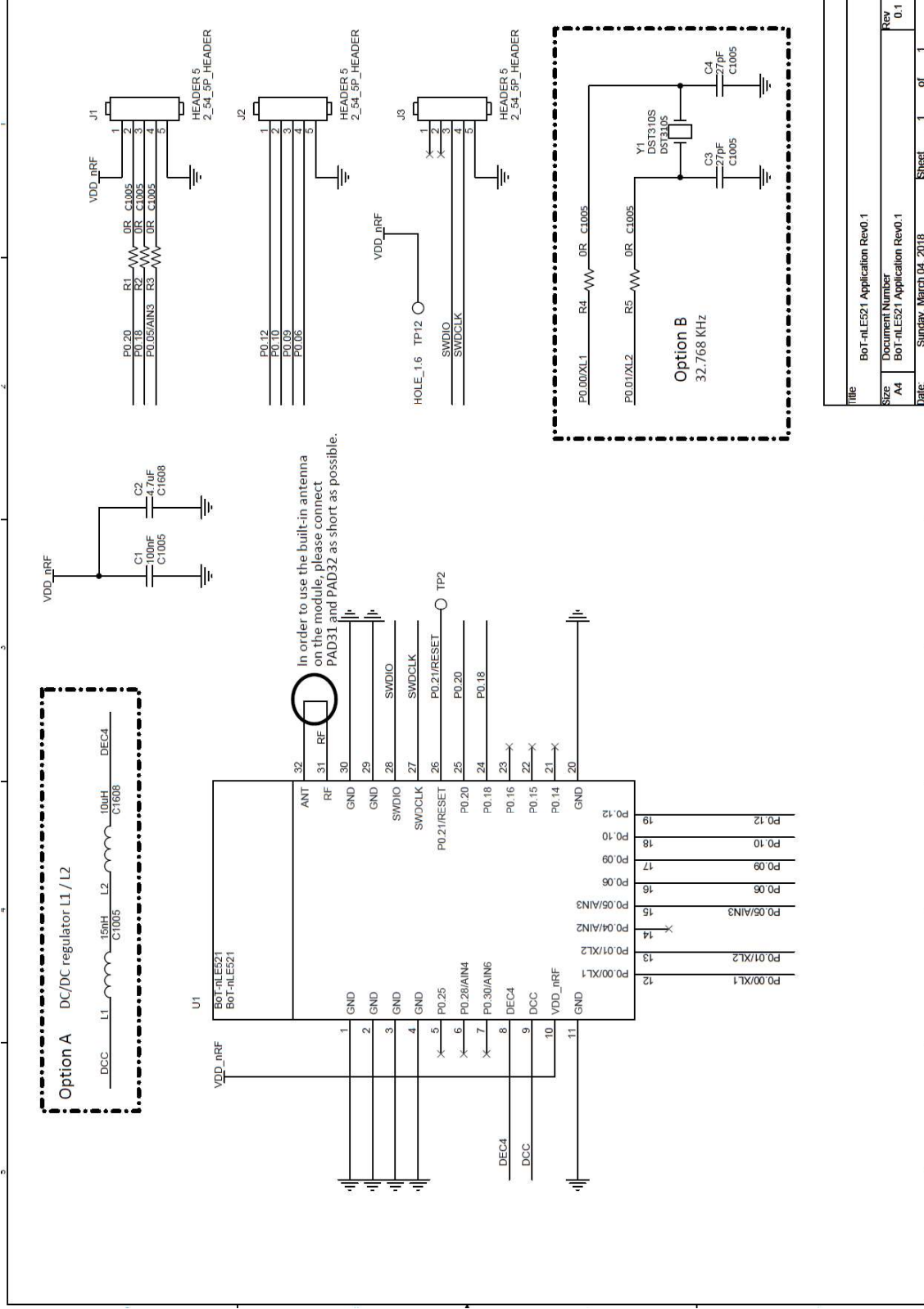

Title		BoT-nLE521 Application Rev0.1	
Size		Document Number	
A4		BoT-nLE521 Application Rev0.1	Rev 0.1
Date:	Sunday, March 04, 2018	Sheet	1 of 1

## 5. Antenna

### 5.1 Antenna Layout Guide

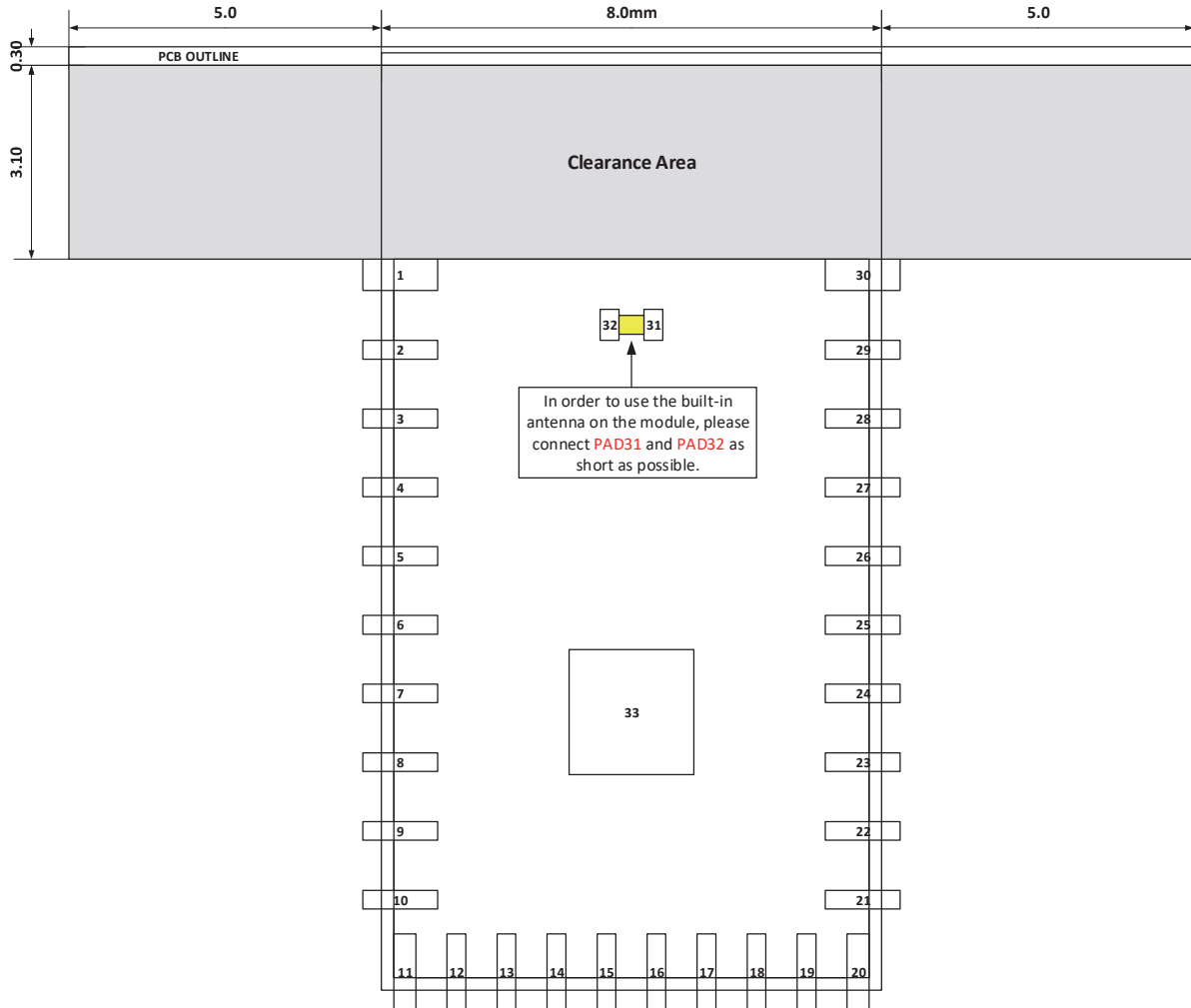



## 6. Certification

### 6.1 FCC Statement

#### FCC Statement

This device complies with part 15 of the FCC Rules. Operation is subject to the following two conditions: (1) This device may not cause harmful interference, and (2) this device must accept any interference received, including interference that may cause undesired operation. Changes or modifications not expressly approved by the party responsible for compliance could void the user's authority to operate the equipment.

#### FCC Radiation Exposure Statement

This modular complies with FCC RF radiation exposure limits set forth for an uncontrolled environment. This transmitter must not be co-located or operating in conjunction with any other antenna or transmitter.

If the FCC identification number is not visible when the module is installed inside another device, then the outside of the device into which the module is installed must also display a label referring to the enclosed module.

This exterior label can use wording such as the following: "Contains Transmitter Module  
FCC ID: **2APB6-BOT-NLE521** Or Contains FCC ID: **2APB6-BOT-NLE521**

When the module is installed inside another device, the user manual of the host must contain below warning statements;

1. This device complies with Part 15 of the FCC Rules. Operation is subject to the following two conditions:

- (1) This device may not cause harmful interference.
- (2) This device must accept any interference received, including interference that may cause undesired operation.

2. Changes or modifications not expressly approved by the party responsible for compliance could void the user's authority to operate the equipment.

The devices must be installed and used in strict accordance with the manufacturer's instructions as described in the user documentation that comes with the product

Any company of the host device which install this modular with limit modular approval should perform the test of radiated emission and spurious emission according to FCC part 15C : 15.247 and 15.209 requirement, Only if the test result comply with FCC part 15C : 15.247 and 15.209 requirement then the host can be sold legally.

# Operation Description

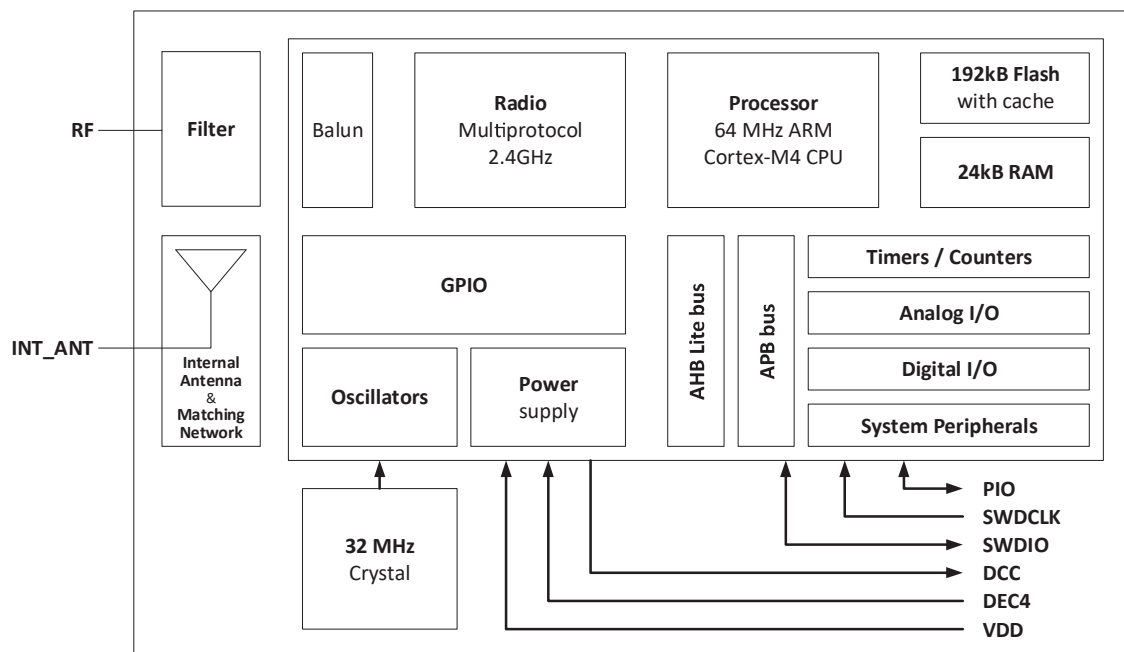

BoT-nLE521 BLE wireless Module transmits and receives 2.4GHz frequency

The default operating voltage is 3.3 V, and the BLE transmission / reception data is processed by the main processor

BoT-nLE521 wireless transmit / receive data operates with AT + Command stored in main processor.

**Product Label Sample with FCC Label information**

Following is a sample copy of the label that will be placed on the rear cabinet of the product. The FCC ID Label and compliance statement are marked in the product label. The warning statement and Information to the User are described in the user manual.

- Model: BoT-nLE521



**Label Location**

The label shown shall be permanently affixed at a conspicuous location on the device and be readily visible to the user at the time purchase.(Labeling requirements per 2.925)

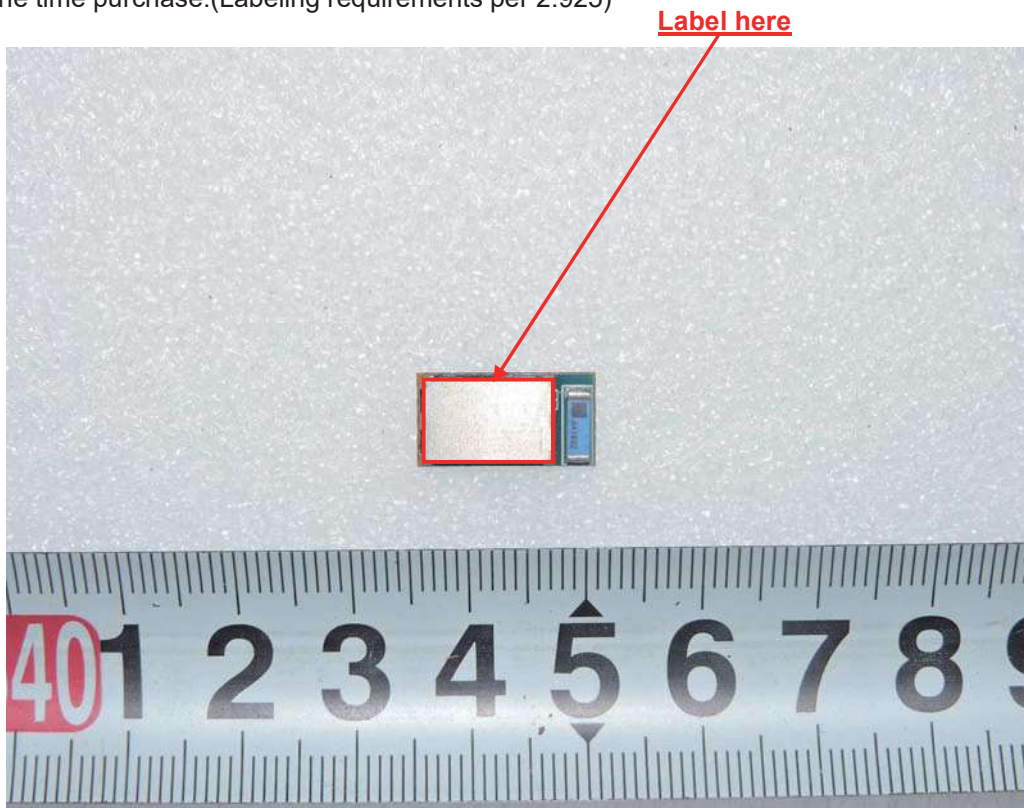

**Standard Applicable:**

According to §1.1307(b)(1), systems operating under the provisions of this section shall be operated in a manner that ensure that the public is not exposed to radio frequency energy level in excess of the Commission’s guideline.

This is a Portable device with its physical nature to be used nearby, the distance between radiating structure and human is less than 20 cm.

As per KDB 447498 D01, The 1-g and 10-g SAR test exclusion thresholds for 100 MHz to 6 GHz at test separation distances ≤ 50 mm are determined by:

$$[(\text{max. power of channel, including tune-up tolerance, mW}) / (\text{min. test separation distance, mm})] * [\sqrt{f(\text{GHz})}] \leq 3.0 \text{ for 1-g SAR and } \leq 7.5 \text{ for 10-g extremity SAR, where}$$

f (GHz) is the RF channel transmit frequency in GHz  
 Power and distance are rounded to the nearest mW and mm before calculation  
 The result is rounded to one decimal place for comparison

**Measurement Result:**

This is a portable device and the Max peak output power is **(1.41 mW)** lower than the threshold given and derived as above, where

$$= 1.41 \text{ (mW)} / 5 \text{ (mm)} * \sqrt{2.480 \text{ (GHz)}} = 0.44 < 3.00$$

As the result of calculation result indicates, the RF exposure generating from given transmitter (transmitter employed digital modulation) can be excluded from SAR measurement, and is deemed compliant with RF exposure as per FCC.

Frequency [MHz]	Output Power [dBm]	Target power [dBm]	Allowed tolerance [dB]	Max tune up power [dBm]	Max tune up power [mW]	Separation distance [mm]	RF exposure	Limit
2 402	1.34	-0.5	± 2.00	1.5	1.41	5	0.44	3.00
2 440	1.33	-0.5	± 2.00	1.5	1.41	5	0.44	3.00
<b>2 480</b>	<b>1.33</b>	<b>-0.5</b>	<b>± 2.00</b>	<b>1.5</b>	<b>1.41</b>	<b>5</b>	<b>0.44</b>	<b>3.00</b>

ex) Target power[dBm] = Max tune up power[dBm] – Allowed tolerance[dB]