

TEST REPORT

Report No.: 22040253HKG-001

Nacon (HK) Limited

Application For Certification
For FCC: Original Grant
For IC: Class II Permissive Change

FCC ID: 2AVPR-800PROAR
IC: 25872-800PRO

Transceiver – 2.4GHz

Prepared and Checked by:

Approved by:

Signed on File
Wong Cheuk Ho, Herbert
Lead Engineer

Wong Kwok Yeung, Kenneth
Assistant Supervisor
Date: June 14, 2022

Intertek's standard Terms and Conditions can be obtained at our website <http://www.intertek.com/terms/>.

The test report only allows to be revised within the retention period unless further standard or the requirement was noticed.

This report is for the exclusive use of Intertek's Client and is provided pursuant to the agreement between Intertek and its Client. Intertek's responsibility and liability are limited to the terms and conditions of the agreement. Intertek assumes no liability to any party, other than to the Client in accordance with the agreement, for any loss, expense or damage occasioned by the use of this report. Only the Client is authorized to permit copying or distribution of this report and then only in its entirety. Any use of the Intertek name or one of its marks for the sale or advertisement of the tested material, product or service must first be approved in writing by Intertek. The observations and test results in this report are relevant only to the sample tested. This report by itself does not imply that the material, product, or service is or has ever been under an Intertek certification program.

© 2017 Intertek

TEST REPORT

GENERAL INFORMATION

Grantee:	Nacon (HK) Limited
Grantee Address:	Unit 1505, 148 Electric Road, North Point, Hong Kong.
Contact Person:	Johnny Wong
Tel:	+852 2512 3111
E-mail:	johnny@nacon.com.hk
Manufacturer:	Nacon (HK) Limited
Manufacturer Address:	Unit 1505, 148 Electric Road, North Point, Hong Kong.
Brand Name:	RIG
Model:	RIG 800 PRO
HVIN:	800PRO
PMN:	RIG 800 PRO
Type of EUT:	Transceiver
Description of EUT:	Gaming Headset
FCC ID / IC:	2AVPR-800PROAR / 25872-800PRO
Date of Sample Submitted:	April 06, 2022
Date of Test:	April 06, 2022 to May 06, 2022
Report No.:	22040253HKG-001
Report Date:	June 14, 2022
Environmental Conditions:	Temperature: +10 to 40°C Humidity: 10 to 90%
Conclusion:	Test was conducted by client submitted sample. The submitted sample as received complied with the 47 CFR Part 15 / RSS-210 Issue 10 Certification.

TEST REPORT

SUMMARY OF TEST RESULT

Test Specification	Reference	Results
Transmitter Power Line Conducted Emissions	15.207 / RSS-Gen 8.8	Pass
Radiated Emission	15.249, 15.209 /	Pass
Radiated Emission on the Bandedge	RSS-210 B.10, RSS-Gen 8.9	
Radiated Emission in Restricted Bands	15.205 / RSS-Gen 8.10	Pass

For all technical data, which can be referred to Annex B – Report cover sheet.

For electronic filing, the Annex B – Report cover sheet is saved with filename: Annex B.pdf.

The equipment under test is found to be complying with the following standards:

FCC Part 15, October 1, 2020 Edition

RSS-210 Issue 10 Amendment 1, April 2020

RSS-Gen Issue 5 Amendment 2, February 2021

- Note:
1. The EUT uses a permanently attached antenna which, in accordance to section 15.203, is considered sufficient to comply with the provisions of this section.
 2. Pursuant to FCC part 15 Section 15.215(c), the 20 dB bandwidth of the emission was contained within the frequency band designated (mentioned as above) which the EUT operated. The effects, if any, from frequency sweeping, frequency hopping, other modulation techniques and frequency stability over excepted variations in temperature and supply voltage were considered.

TEST REPORT

TABLE OF CONTENTS

1.0 GENERAL DESCRIPTION 5

1.1 Product Description5

1.2 Related Submittal(s) Grants5

1.3 Test Methodology.....5

1.4 Test Facility5

2.0 SYSTEM TEST CONFIGURATION..... 6

2.1 Justification.....6

2.2 EUT Exercising Software.....6

2.3 Special Accessories6

2.4 Measurement Uncertainty.....6

2.5 Support Equipment List and Description.....7

3.0 EMISSION RESULTS..... 8

3.1 Field Strength Calculation8

3.2 Radiated Emission Configuration Photograph.....9

3.3 Radiated Emission Data9

3.4 Conducted Emission Configuration Photograph9

3.5 Conducted Emission Data9

4.0 EQUIPMENT PHOTOGRAPHS 17

5.0 PRODUCT LABELLING..... 17

6.0 TECHNICAL SPECIFICATIONS 17

7.0 INSTRUCTION MANUAL..... 17

8.0 MISCELLANEOUS INFORMATION 18

8.1 Radiated Emission on the Bandedge.....18

8.2 Discussion of Pulse Desensitization.....21

8.3 Emissions Test Procedures.....21

8.4 Occupied Bandwidth.....24

9.0 EQUIPMENT LIST 25

TEST REPORT

1.0 GENERAL DESCRIPTION

1.1 Product Description

The Equipment Under Test is a Gaming Headset of 2.4GHz Wireless Headphone with Dongle and Docking (Cradle). The EUT operates at frequency range of 2402MHz to 2480MHz. The USB port on the Headphone is for charging purpose only. The EUT is powered by 3.7V rechargeable battery.

Antenna Type: Internal, Integral

For electronic filing, the brief circuit description is saved with filename: descri.pdf.

1.2 Related Submittal(s) Grants/Purpose of Change

For FCC, this is a single application for certification of a transceiver.

For IC, this is a Class II Permissive Change of a transceiver.

Purpose of change for this application is saved in Purpose of change.pdf

1.3 Test Methodology

Both AC mains line-conducted and radiated emission measurements were performed according to the procedures in ANSI C63.10 (2013). All radiated measurements were performed in an 3m Chamber. Preliminary scans were performed in the 3m Chamber only to determine worst case modes. All radiated tests were performed at an antenna to EUT distance of 3 meters, unless stated otherwise in the “**Justification Section**” of this Application.

1.4 Test Facility

The 3m Chamber and conducted measurement facility used to collect the radiated data is located at Workshop No. 3, G/F., World-Wide Industrial Centre, 43-47 Shan Mei Street, Fo Tan, Sha Tin, N.T., Hong Kong SAR, China. This test facility and site measurement data have been placed on file with the FCC and IC No. 2042H, CABID is “HKAP01”.

TEST REPORT

2.0 SYSTEM TEST CONFIGURATION

2.1 Justification

The system was configured for testing in a typical fashion (as a customer would normally use it), and in the confines as outlined in ANSI C63.10 (2013).

There are three powering methods for the headphone (EUT).

Case 1) Powered by Internal 3.7V rechargeable battery.

Case 2) Powered by Notebook USB port (5VDC).

Case 3) Powered by Notebook USB port (5VDC) with Docking (Cradle).

All powering methods were tested. For 2.4GHz portion, worst case data (Case 3) is shown only.

For maximizing emissions, the EUT was rotated through 360°, the antenna height was varied from 1 meter to 4 meters above the ground plane, and the antenna polarization was changed. This step by step procedure for maximizing emissions led to the data reported in Exhibit 3.0.

The rear of unit shall be flushed with the rear of the table.

The equipment under test (EUT) was configured for testing in a typical fashion (as a customer would normally use it). The EUT was mounted to a plastic stand if necessary and placed on the wooden turntable, which enabled the engineer to maximize emissions through its placement in the three orthogonal axes.

2.2 EUT Exercising Software

The EUT exercise program (if any) used during radiated testing was designed to exercise the various system components in a manner similar to a typical use.

2.3 Special Accessories

There are no special accessories necessary for compliance of this product.

2.4 Measurement Uncertainty

Decision Rule for compliance: For FCC/IC standard, the measured value must be within the limits of applicable standard without accounting for the measurement uncertainty. For EN/IEC/HKTA/HKTC standard, conformity rules will be used as per standard directly excepted EN/IEC 61000-3-2, EN/IEC 61000-3-3, HKTA1004, HKCA1008, HKTA1019, HKTA1020, HKTA1041 and HKTA1044. For these excepted or not mentioned standards, Cl 4.2.2 of ILAC-G8:09/2019 decision rules will be reference and guard band will be equal to our measurement uncertainty with 95% confidence level (k=2). In case, the measured value is within guard band region, undetermined decision will be used.

TEST REPORT

2.5 Support Equipment List and Description

Provided by Intertek:
HP Notebook Computer (Adaptor Model: HSTNN-CA15)
1 X LAN Cable of 2m long

Provided by Applicant:
1 X USB Cable of 1m long

TEST REPORT

3.0 EMISSION RESULTS

Data is included of the worst-case configuration (the configuration which resulted in the highest emission levels). A sample calculation, configuration photographs and data tables of the emissions are included.

3.1 Field Strength Calculation

The field strength is calculated by adding the Antenna Factor and Cable Factor, and subtracting the Amplifier Gain (if any), Average Factor (optional) from the measured reading. The basic equation with a sample calculation is as follows:

$$FS = RA + AF + CF - AG - AV$$

where FS = Field Strength in dB μ V/m

RA = Receiver Amplitude (including preamplifier) in dB μ V

CF = Cable Attenuation Factor in dB

AF = Antenna Factor in dB

AG = Amplifier Gain in dB

AV = Average Factor in dB

In the following table(s), the reading shown on the data table reflects the preamplifier gain. An example for the calculations in the following table is as follows:

$$FS = RR + LF$$

where FS = Field Strength in dB μ V/m

RR = RA - AG - AV in dB μ V

LF = CF + AF in dB

Assume a receiver reading of 52.0 dB μ V is obtained. The antenna factor of 7.4 dB and cable factor of 1.6 dB are added. The amplifier gain of 29 dB and average factor of 5 dB are subtracted, giving a field strength of 27 dB μ V/m. This value in dB μ V/m was converted to its corresponding level in μ V/m.

$$RA = 52.0 \text{ dB}\mu\text{V/m}$$

$$AF = 7.4 \text{ dB}$$

$$CF = 1.6 \text{ dB}$$

$$AG = 29.0 \text{ dB}$$

$$AV = 5.0 \text{ dB}$$

$$FS = RR + LF$$

$$FS = 18 + 9 = 27 \text{ dB}\mu\text{V/m}$$

$$RR = 18.0 \text{ dB}\mu\text{V}$$

$$LF = 9.0 \text{ dB}$$

$$\text{Level in } \mu\text{V/m} = \text{Common Antilogarithm } [(27 \text{ dB}\mu\text{V/m})/20] = 22.4 \mu\text{V/m}$$

TEST REPORT

3.2 Radiated Emission Configuration Photograph

The worst case in radiated emission was found at 364.528 MHz

For electronic filing, the worst case radiated emission configuration photographs are saved with filename: radiated photos.pdf.

3.3 Radiated Emission Data

The data on the following page lists the significant emission frequencies, the limit and the margin of compliance. Numbers with a minus sign are below the limit.

Judgment: Passed by 7.8 dB

3.4 Conducted Emission Configuration Photograph

The worst case in line-conducted emission was found at 0.164 MHz

For electronic filing, the worst-case line-conducted configuration photographs are saved with filename: conducted photo.pdf.

3.5 Conducted Emission Data

For electronic filing, the graph and data table of conducted emission is saved with filename: conducted.pdf.

Judgment: Pass by 7.9 dB

TEST REPORT

CONDUCTED EMISSION

Model/HVIN: RIG 800 PRO / 800PRO

Date of Test: May 06, 2022

Worst-Case Operating Mode: Transmitting (Powered by Notebook USB port with Docking Base)

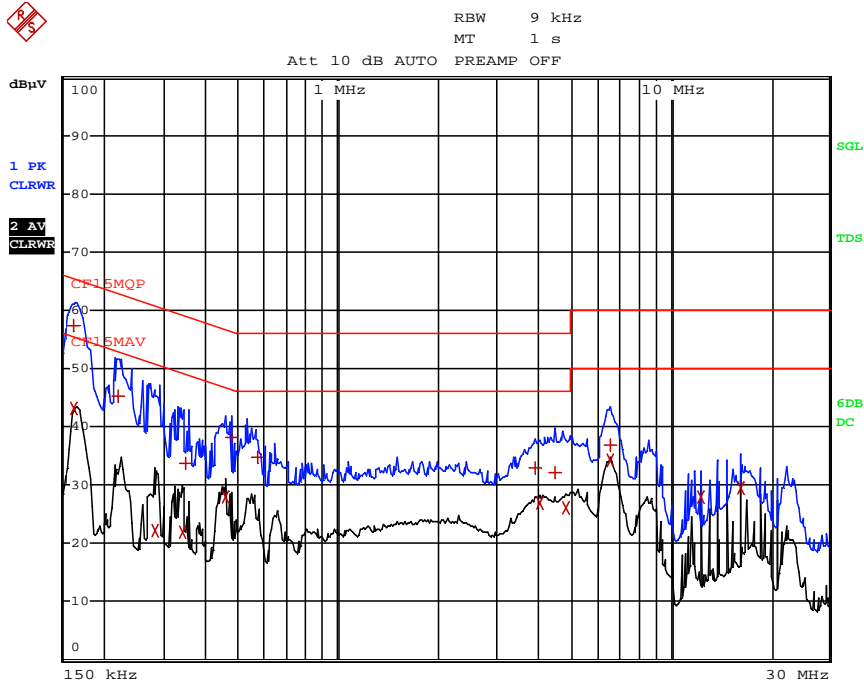

EDIT PEAK LIST (Final Measurement Results)

Trace1: CF15MQP
Trace2: CF15MAV
Trace3: ---

TRACE	FREQUENCY	LEVEL dBµV	DELTA LIMIT dB
1 Quasi Peak	163.5 kHz	57.41 N	-7.86
2 CISPR Average	163.5 kHz	43.21 L1	-12.06
1 Quasi Peak	222 kHz	45.32 L1	-17.42
2 CISPR Average	280.5 kHz	22.11 L1	-28.68
2 CISPR Average	339 kHz	21.87 L1	-27.35
1 Quasi Peak	352.5 kHz	33.82 L1	-25.08
2 CISPR Average	456 kHz	27.89 L1	-18.86
1 Quasi Peak	478.5 kHz	38.19 N	-18.16
1 Quasi Peak	573 kHz	34.87 L1	-21.12
1 Quasi Peak	3.93 MHz	32.81 N	-23.19
2 CISPR Average	4.047 MHz	26.99 L1	-19.00
1 Quasi Peak	4.4925 MHz	32.10 N	-23.89
2 CISPR Average	4.821 MHz	26.02 L1	-19.97
1 Quasi Peak	6.5985 MHz	36.98 L1	-23.01
2 CISPR Average	6.603 MHz	34.24 N	-15.75
2 CISPR Average	12.3585 MHz	28.03 L1	-21.96
2 CISPR Average	16.224 MHz	29.54 L1	-20.45

Date: 6.MAY.2022 11:51:49

TEST REPORT

Model/HVIN: RIG 800 PRO / 800PRO

Date of Test: May 06, 2022

Worst-Case Operating Mode: Transmitting (Powered by Notebook USB port)

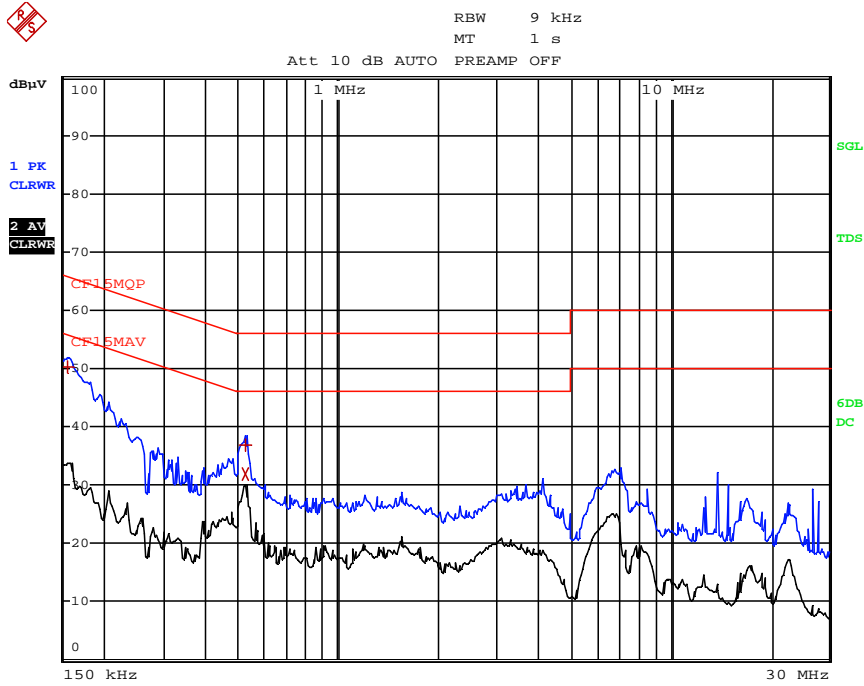

EDIT PEAK LIST (Final Measurement Results)

```
Trace1: CF15MQP
Trace2: CF15MAV
Trace3: ---
```

TRACE	FREQUENCY	LEVEL dBμV	DELTA LIMIT dB
1 Quasi Peak	154.5 kHz	50.16 L1	-15.58
1 Quasi Peak	523.5 kHz	36.75 N	-19.24
2 CISPR Average	523.5 kHz	31.83 N	-14.16

Note: Measurement Uncertainty is ±4.2dB at a level of confidence of 95%.

TEST REPORT

RADIATED EMISSIONS

Model/HVIN: RIG 800 PRO / 800PRO

Date of Test: May 06, 2022

Worst-Case Operating Mode: Transmitting

Table 1
Pursuant to FCC Part 15 Section 15.249 / RSS-210 B10.0 Requirement

Lowest Channel

Polarization	Frequency (MHz)	Reading (dBμV)	Pre-Amp Gain (dB)	Antenna Factor (dB)	Net at 3m - Average (dBμV/m)	Average Limit at 3m (dBμV/m)	Margin (dB)
V	2402.000	87.1	33	29.4	83.5	94.0	-10.5
V	4804.000	28.8	33	34.9	30.7	54.0	-23.3
V	7206.000	28.6	33	37.9	33.5	54.0	-20.5
H	9608.000	25.9	33	40.4	33.3	54.0	-20.7
V	12010.000	25.9	33	40.5	33.4	54.0	-20.6
V	14412.000	29.3	33	40.0	36.3	54.0	-17.7

Polarization	Frequency (MHz)	Reading (dBμV)	Pre-Amp Gain (dB)	Antenna Factor (dB)	Net at 3m - Peak (dBμV/m)	Peak Limit at 3m (dBμV/m)	Margin (dB)
V	2402.000	109.4	33	29.4	105.8	114.0	-8.2
V	4804.000	41.4	33	34.9	43.3	74.0	-30.7
V	7206.000	41.4	33	37.9	46.3	74.0	-27.7
H	9608.000	39.7	33	40.4	47.1	74.0	-26.9
V	12010.000	38.9	33	40.5	46.4	74.0	-27.6
V	14412.000	42.7	33	40.0	49.7	74.0	-24.3

- NOTES:
1. Peak Detector Data unless otherwise stated.
 2. Average detector is applied according to ANSI C63.10.
 3. All measurements were made at 3 meters.
 4. Negative value in the margin column shows emission below limit.
 5. Horn antenna is used for the emission over 1000MHz.
 6. Emissions within the restricted band meets the requirement of FCC Part 15 Section 15.205 / RSS-Gen Section 8.10.
 7. Measurement Uncertainty is ±5.3dB at a level of confidence of 95%.

TEST REPORT

Model/HVIN: RIG 800 PRO / 800PRO
Date of Test: May 06, 2022
Worst-Case Operating Mode: Transmitting

**Table 2
Pursuant to FCC Part 15 Section 15.249 / RSS-210 B10.0 Requirement**

Middle Channel

Polarization	Frequency (MHz)	Reading (dBμV)	Pre-Amp Gain (dB)	Antenna Factor (dB)	Net at 3m - Average (dBμV/m)	Average Limit at 3m (dBμV/m)	Margin (dB)
V	2440.000	87.0	33	29.4	83.4	94.0	-10.6
V	4880.000	28.5	33	34.9	30.4	54.0	-23.6
V	7320.000	28.3	33	37.9	33.2	54.0	-20.8
H	9760.000	26.5	33	40.4	33.9	54.0	-20.1
V	12200.000	26.1	33	40.5	33.6	54.0	-20.4
V	14640.000	30.6	33	38.4	36.0	54.0	-18.0

Polarization	Frequency (MHz)	Reading (dBμV)	Pre-Amp Gain (dB)	Antenna Factor (dB)	Net at 3m - Peak (dBμV/m)	Peak Limit at 3m (dBμV/m)	Margin (dB)
V	2440.000	108.1	33	29.4	104.5	114.0	-9.5
V	4880.000	41.3	33	34.9	43.2	74.0	-30.8
V	7320.000	41.1	33	37.9	46.0	74.0	-28.0
H	9760.000	39.5	33	40.4	46.9	74.0	-27.1
V	12200.000	39.2	33	40.5	46.7	74.0	-27.3
V	14640.000	44.4	33	38.4	49.8	74.0	-24.2

- NOTES:
1. Peak Detector Data unless otherwise stated.
 2. Average detector is applied according to ANSI C63.10.
 3. All measurements were made at 3 meters.
 4. Negative value in the margin column shows emission below limit.
 5. Horn antenna is used for the emission over 1000MHz.
 6. Emissions within the restricted band meets the requirement of FCC Part 15 Section 15.205 / RSS-Gen Section 8.10.
 7. Measurement Uncertainty is ±5.3dB at a level of confidence of 95%.

TEST REPORT

Model/HVIN: RIG 800 PRO / 800PRO
Date of Test: May 06, 2022
Worst-Case Operating Mode: Transmitting

**Table 3
Pursuant to FCC Part 15 Section 15.249 / RSS-210 B10.0 Requirement**

Highest Channel

Polarization	Frequency (MHz)	Reading (dBμV)	Pre-Amp Gain (dB)	Antenna Factor (dB)	Net at 3m - Average (dBμV/m)	Average Limit at 3m (dBμV/m)	Margin (dB)
V	2480.000	86.4	33	29.4	82.8	94.0	-11.2
V	4960.000	28.9	33	34.9	30.8	54.0	-23.2
V	7440.000	28.7	33	37.9	33.6	54.0	-20.4
H	9920.000	26.7	33	40.4	34.1	54.0	-19.9
V	12400.000	26.3	33	40.5	33.8	54.0	-20.2
V	14880.000	30.8	33	38.4	36.2	54.0	-17.8

Polarization	Frequency (MHz)	Reading (dBμV)	Pre-Amp Gain (dB)	Antenna Factor (dB)	Net at 3m - Peak (dBμV/m)	Peak Limit at 3m (dBμV/m)	Margin (dB)
V	2480.000	107.8	33	29.4	104.2	114.0	-9.8
V	4960.000	41.3	33	34.9	43.2	74.0	-30.8
V	7440.000	41.2	33	37.9	46.1	74.0	-27.9
H	9920.000	39.5	33	40.4	46.9	74.0	-27.1
V	12400.000	39.0	33	40.5	46.5	74.0	-27.5
V	14880.000	43.8	33	38.4	49.2	74.0	-24.8

- NOTES: 1. Peak Detector Data unless otherwise stated.
2. Average detector is applied according to ANSI C63.10.
3. All measurements were made at 3 meters.
4. Negative value in the margin column shows emission below limit.
5. Horn antenna is used for the emission over 1000MHz.
6. Emissions within the restricted band meets the requirement of FCC Part 15 Section 15.205 / RSS-Gen Section 8.10.
7. Measurement Uncertainty is ±5.3dB at a level of confidence of 95%.

TEST REPORT

Model/HVIN: RIG 800 PRO / 800PRO
Date of Test: May 06, 2022
Worst-Case Operating Mode: Transmitting
(Powered by Notebook USB port)

Table 4
Pursuant to FCC Part 15 Section 15.209 / RSS-GEN 8.9 Requirement

Polarization	Frequency (MHz)	Reading (dBμV)	Pre-amp (dB)	Antenna Factor (dB)	Net at 3m (dBμV/m)	Limit at 3m (dBμV/m)	Margin (dB)
V	31.092	27.2	16	10.0	21.2	40.0	-18.8
V	57.524	20.6	16	11.0	15.6	40.0	-24.4
V	113.662	19.6	16	14.0	17.6	43.5	-25.9
V	119.725	18.5	16	14.0	16.5	43.5	-27.0
V	131.728	19.8	16	14.0	17.8	43.5	-25.7
H	256.012	20.6	16	21.0	25.6	46.0	-20.4
H	323.546	19.4	16	24.0	27.4	46.0	-18.6
H	373.622	21.2	16	24.0	29.2	46.0	-16.8
V	470.622	21.6	16	26.0	31.6	46.0	-14.4

- NOTES:
1. Quasi-Peak Detector Data unless otherwise stated.
 2. All measurements were made at 3 meters.
 3. Negative value in the margin column shows emission below limit.
 4. Horn antenna is used for the emission over 1000MHz.
 5. Emissions within the restricted band meets the requirement of FCC Part 15 Section 15.205 / RSS-Gen Section 8.10.
 6. Measurement Uncertainty is ±5.3dB at a level of confidence of 95%.

TEST REPORT

Model/HVIN: RIG 800 PRO / 800PRO

Date of Test: May 06, 2022

Worst-Case Operating Mode: Transmitting

(Powered by Notebook USB port with Docking Base)

Table 5
Pursuant to FCC Part 15 Section 15.209 / RSS-GEN 8.9 Requirement

Polarization	Frequency (MHz)	Reading (dBμV)	Pre-amp (dB)	Antenna Factor (dB)	Net at 3m (dBμV/m)	Limit at 3m (dBμV/m)	Margin (dB)
V	31.092	26.8	16	10.0	20.8	40.0	-19.2
V	58.978	20.8	16	11.0	15.8	40.0	-24.2
V	118.148	20.4	16	14.0	18.4	43.5	-25.1
V	131.244	22.5	16	14.0	20.5	43.5	-23.0
V	148.825	20.5	16	14.0	18.5	43.5	-25.0
V	200.235	18.8	16	16.0	18.8	43.5	-24.7
H	259.526	20.5	16	21.0	25.5	46.0	-20.5
H	282.928	19.5	16	22.0	25.5	46.0	-20.5
V	364.528	30.2	16	24.0	38.2	46.0	-7.8
V	396.782	18.2	16	25.0	27.2	46.0	-18.8
V	480.202	18.8	16	26.0	28.8	46.0	-17.2
H	707.908	18.8	16	30.0	32.8	46.0	-13.2

- NOTES:
1. Quasi-Peak Detector Data unless otherwise stated.
 2. All measurements were made at 3 meters.
 3. Negative value in the margin column shows emission below limit.
 4. Horn antenna is used for the emission over 1000MHz.
 5. Emissions within the restricted band meets the requirement of FCC Part 15 Section 15.205 / RSS-Gen Section 8.10.
 6. Measurement Uncertainty is ±5.3dB at a level of confidence of 95%.

TEST REPORT

4.0 EQUIPMENT PHOTOGRAPHS

For electronic filing, the photographs are saved with filename: external photos.pdf and internal photos.pdf.

5.0 PRODUCT LABELLING

For electronics filing, the FCC ID & IC label artwork and the label location are saved with filename: label.pdf.

6.0 TECHNICAL SPECIFICATIONS

For electronic filing, the block diagram and schematic of the tested EUT are saved with filename: block.pdf and circuit.pdf respectively.

7.0 INSTRUCTION MANUAL

For electronic filing, a preliminary copy of the Instruction Manual is saved with filename: manual.pdf.

This manual will be provided to the end-user with each unit sold/leased in the United States and Canada.

TEST REPORT

8.0 MISCELLANEOUS INFORMATION

The miscellaneous information includes details of the test procedure and measured bandwidth / calculation of factor such as pulse desensitization.

8.1 Radiated Emission on the Bandedge

From the following plots, they show that the fundamental emissions are confined in the specified band (2400MHz to 2483.5MHz). In case of the fundamental emissions are within two standard bandwidths from the bandedge, the delta measurement technique is used for determining bandedge compliance. Standard bandwidth is the bandwidth specified by ANSI C63.10 (2013) for frequency being measured.

Emissions radiated outside of the specified frequency bands, except harmonics, are attenuated by 50dB below the level of the fundamental or to the general radiated emissions limits in Section 15.209 / RSS-Gen 8.9, whichever is the lesser attenuation, which meet the requirement of Part 15.249(d) / RSS-210 B.10.

TEST REPORT

PEAK MEASUREMENT

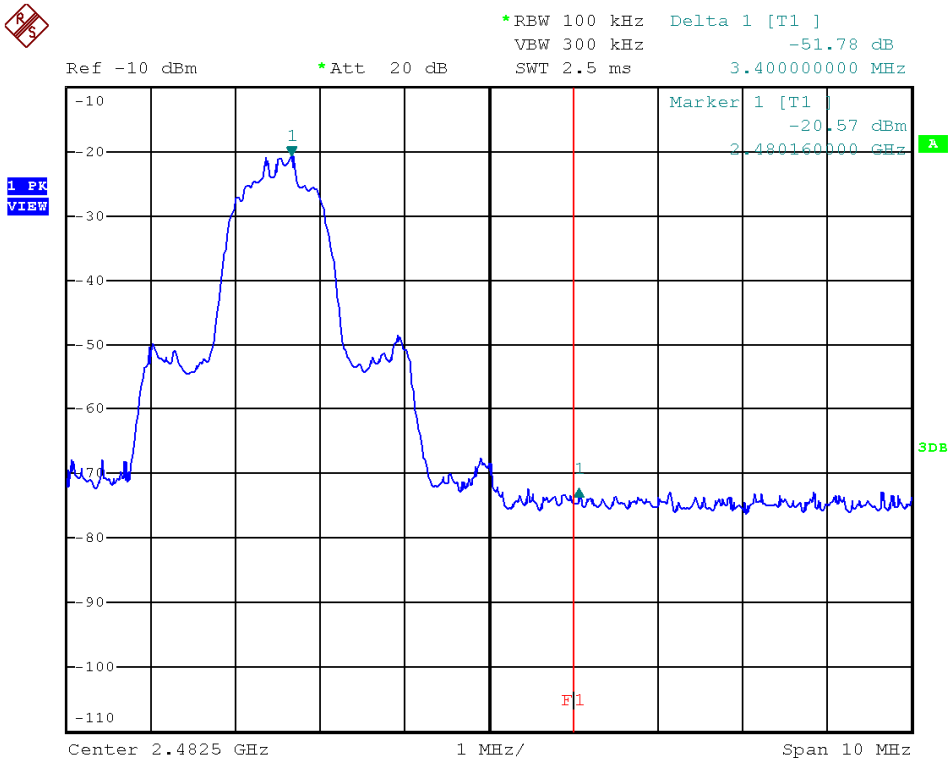
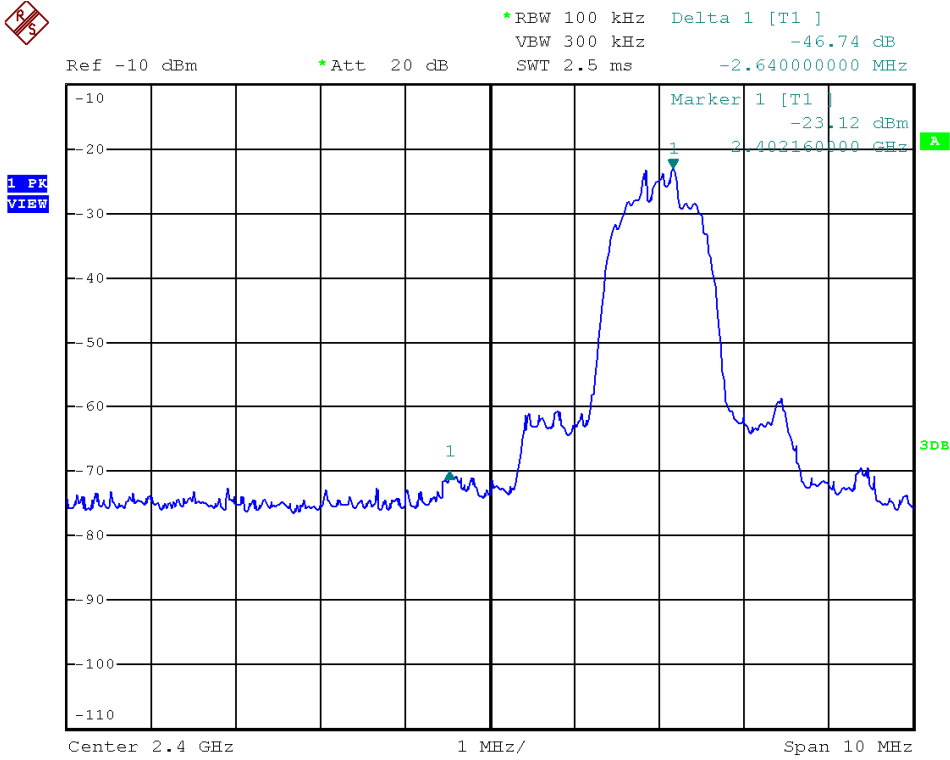

TEST REPORT

PEAK MEASUREMENT

Bandedge compliance is determined by applying marker-delta method, i.e. (Bandedge Plot).

Lower bandedge

Peak Resultant field strength = Fundamental emissions (peak value) – delta from the plot

=105.8 dB μ V/m - 46.7 dB
=59.1 dB μ V/m

Average Resultant field strength = Fundamental emissions (average value) – delta from the plot

=83.5 dB μ V/m - 46.7 dB
=36.8 dB μ V/m

Upper bandedge

Peak Resultant field strength = Fundamental emissions (peak value) – delta from the plot

=104.2 dB μ V/m - 51.8 dB
=52.4 dB μ V/m

Average Resultant field strength = Fundamental emissions (average value) – delta from the plot

=82.8 dB μ V/m - 51.8 dB
=31.0 dB μ V/m

The resultant field strength meets the general radiated emission limit in Section 15.209 / RSS-Gen 8.9, which does not exceed 74 dB μ V/m (Peak Limit) and 54 dB μ V/m (Average Limit).

TEST REPORT

8.2 Discussion of Pulse Desensitization

Pulse desensitivity is not applicable for this device. The effective period (Teff) is approximately 625 μ s for a digital "1" bit which illustrated on technical specification, with a resolution bandwidth (3dB) of 3MHz, so the pulse desensitivity factor is 0dB.

8.3 Emissions Test Procedures

The following is a description of the test procedure used by Intertek Testing Services Hong Kong Ltd. in the measurements of transmitter operating under the Part 15, Subpart C rules.

The transmitting equipment under test (EUT) is placed on a wooden turntable which is four feet in diameter and approximately 0.8m in height above the ground plane for emission measurement at or below 1GHz and 1.5m in height above the ground plane for emission measurement above 1GHz. During the radiated emissions test, the turntable is rotated and any cables leaving the EUT are manipulated to find the configuration resulting in maximum emissions. The EUT is adjusted through all three orthogonal axis to obtain maximum emission levels. The antenna height and polarization are also varied during the testing to search for maximum signal levels. The height of the antenna is varied from one to four meters.

Detector function for radiated emissions is in peak mode. Average readings, when required, are taken by measuring the duty cycle of the equipment under test and subtracting the corresponding amount in dB from the measured peak readings. A detailed description for the calculation of the average factor can be found in Exhibit 8.3.

The frequency range scanned is from the lowest radio frequency signal generated in the device which is greater than 9 kHz to the tenth harmonic of the highest fundamental frequency or 40 GHz, whichever is lower. For line conducted emissions, the range scanned is 150 kHz to 30 MHz.

The EUT is warmed up for 15 minutes prior to the test.

AC power to the unit is varied from 85% to 115% nominal and variation in the fundamental emission field strength is recorded. If battery powered, a new, fully charged battery is used.

Conducted measurements were made as described in ANSI C63.10 (2013).

The IF bandwidth used for measurement of radiated signal strength was 100 kHz or greater when frequency is below 1000 MHz. Where pulsed transmissions of short enough pulse duration warrant, a greater bandwidth is selected according to the recommendations of Hewlett Packard Application Note 150-2. A discussion of whether pulse desensitivity is applicable to this unit is included in this report (See Exhibit 8.1). Above 1000 MHz, a resolution bandwidth of 3 MHz is used.

Transmitter measurements are normally conducted at a measurement distance of three meters. However, to assure low enough noise floor in the forbidden bands and above 1 GHz, signals are acquired at a distance of one meter or less. All measurements are extrapolated to three meters using inverse scaling, unless otherwise reported. Measurements taken at a closer distance are so marked.

TEST REPORT

8.3.1 Radiated Emission Test Setup

The figure below shows the test setup, which is utilized to make these measurements.

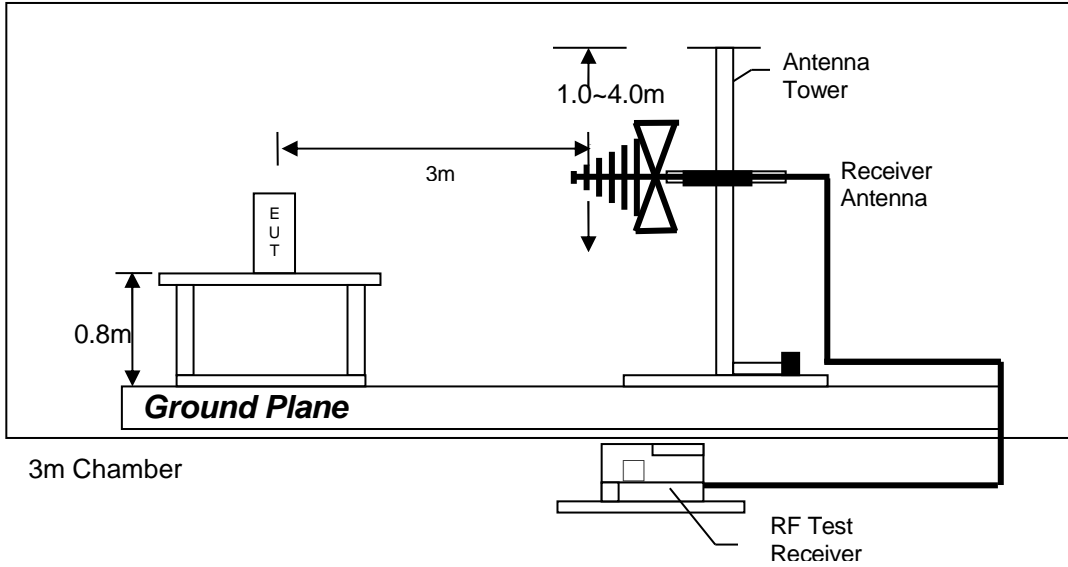

Test setup of radiated emissions up to 1GHz

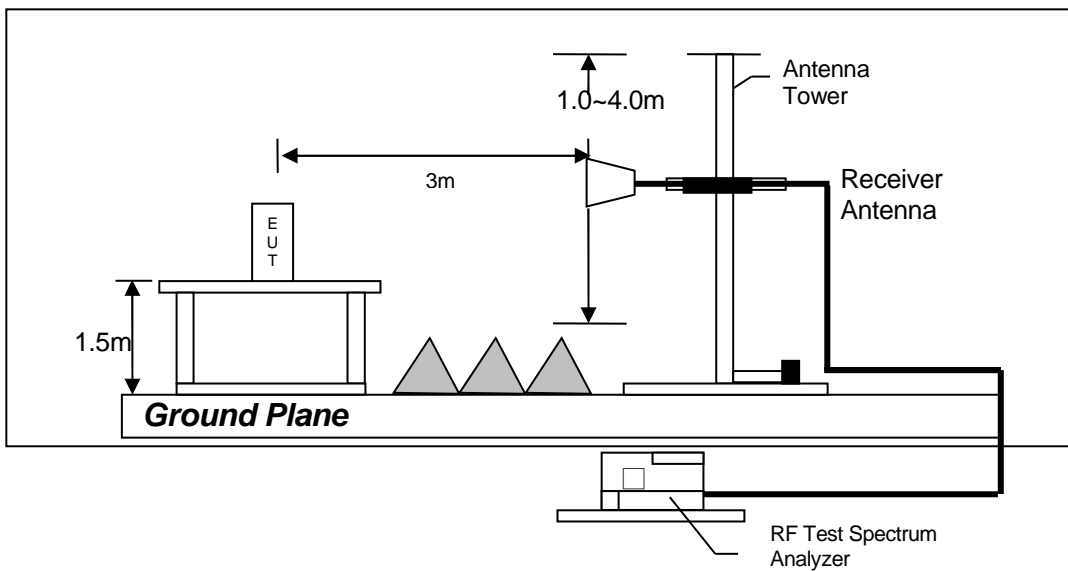

Test setup of radiated emissions above 1GHz

TEST REPORT

8.3.2 Conducted Emission Test Procedures

For tabletop equipment, the EUT along with its peripherals were placed on a 1.0m(W)×1.5m(L) and 0.8m in height wooden table. For floor-standing equipment, the EUT and all cables were insulated, if required, from the ground plane by up to 12 mm of insulating material. The EUT was adjusted to maintain a 0.4 meter space from a vertical reference plane. The EUT was connected to power mains through a line impedance stabilization network (LISN), which provided 50 ohm coupling impedance for measuring instrument and the chassis ground was bounded to the horizontal ground plane of shielded room. The excess power cable between the EUT and the LISN was bundled.

All connecting cables of EUT and peripherals were moved to find the maximum emission.

8.3.3 Conducted Emission Test Setup

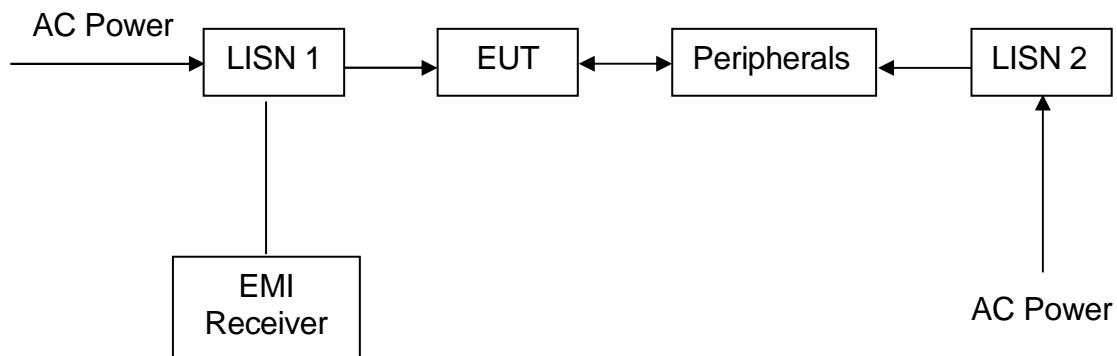

TEST REPORT

8.4 Occupied Bandwidth

Occupied Bandwidth Results:

Occupied Bandwidth (kHz)	
Low Channel: 2402	1170
Middle Channel: 2440	1200
High Channel: 2480	1240

The worst case is shown as below

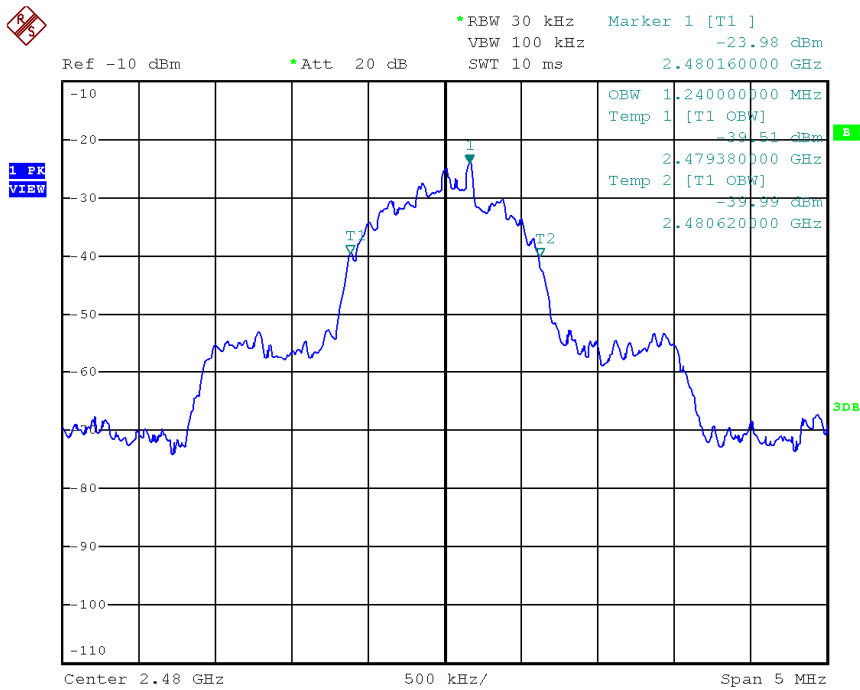

TEST REPORT

9.0 EQUIPMENT LIST

1) Radiated Emissions Test

Equipment	Signal and Spectrum Analyzer (10Hz to 40GHz)	Biconical Antenna (20MHz to 200MHz)	EMI Test Receiver 7GHz
Registration No.	EW-3016	EW-3061	EW-3481
Manufacturer	ROHDESCHWARZ	EMCO	ROHDESCHWARZ
Model No.	FSV40	3142E	ESR7
Calibration Date	October 29, 2021	February 02, 2021	December 21, 2021
Calibration Due Date	October 29, 2022	August 02, 2022	December 21, 2022

Equipment	Log Periodic Antenna	Double Ridged Guide Antenna	Active Loop H-field (9kHz to 30MHz)
Registration No.	EW-3243	EW-1133	EW-3302
Manufacturer	EMCO	EMCO	EMCO
Model No.	3148B	3115	6502
Calibration Date	June 03, 2021	May 26, 2021	July 26, 2021
Calibration Due Date	December 30, 2022	November 26, 2022	July 26, 2023

Equipment	RF Preamplifier (9kHz to 6000MHz)	2.4GHz Notch Filter	14m Double Shield RF Cable (20MHz to 6GHz)
Registration No.	EW-3006b	EW-3435	EW-2074
Manufacturer	SCHWARZBECK	MICROWAVE	RADIALL
Model No.	BBV9718	N0324413	N(m)-RG142-BNC(m) L=14M
Calibration Date	November 25, 2019	November 16, 2019	November 14, 2019
Calibration Due Date	June 25, 2022	June 16, 2022	August 14, 2022

Equipment	Pyramidal Horn Antenna
Registration No.	EW-0905
Manufacturer	EMCO
Model No.	3160-09
Calibration Date	July 23, 2019
Calibration Due Date	June 23, 2022

TEST REPORT

2) Conducted Emissions Test

Equipment	RF Cable 240cm (RG142) (9kHz to 30MHz)	Artificial Mains Network	EMI Test Receiver 7GHz
Registration No.	EW-2454	EW-2501	EW-3481
Manufacturer	RADIALL	ROHDESCHWARZ	ROHDESCHWARZ
Model No.	Bnc m st / 142 / bnc mra 240cm	ENV-216	ESR7
Calibration Date	November 10, 2020	September 11, 2020	December 21, 2021
Calibration Due Date	November 10, 2021	September 11, 2021	December 21, 2022

3) Bandedge Measurement

Equipment	Spectrum Analyzer	5m RF Cable (40GHz)
Registration No.	EW-2466	EW-2701
Manufacturer	ROHDESCHWARZ	RADIALL
Model No.	FSP30	Sma m-m 5m 40G
Calibration Date	November 18, 2019	November 24, 2020
Calibration Due Date	August 18, 2022	August 24, 2022

4) OBW Measurement

Equipment	5m RF Cable (40GHz)	Spectrum Analyzer
Registration No.	EW-2701	EW-2466
Manufacturer	RADIALL	ROHDESCHWARZ
Model No.	Sma m-m 5m 40G	FSP30
Calibration Date	November 24, 2020	November 18, 2019
Calibration Due Date	August 24, 2022	August 18, 2022

5) Control Software for Radiated Emission

Software Information	
Software Name	EMC32
Manufacturer	ROHDESCHWARZ
Software version	10.50.40

END OF TEST REPORT