

SPECIFICATION FOR APPROVAL

CUSTOMER:

CUST P/N:

FINE P/N:

 Φ 50MMX5.0MMX0.9MM

DESC:

A11-50-20.5/0.08*105*12TS-50MM

DATE:

2022/5/20

Version:

A.0

PREPARED BY	CHECKED BY	APPROVED BY	CUSTOMER APPROVE
Meixian Xiang	Chaoling Lan	GongLing Xiang	

Shenzhen Chengxiangsheng Intelligent Technology Co., Ltd

Factory Address: Rm605, No. 2nd LingBeiSiRoad, FengHuang
Community, Fuyong, Bao'an District, Shenzhen, Guangdong, China

TEL: 18923715829

SPECIFICATION

DESC	Φ 20.5x47-10uH-0.08x105Px12TS-50mm-50	Rev: A.0	CUST:	XXX
			CUST P/N:	

1. DIMENSION:(mm)

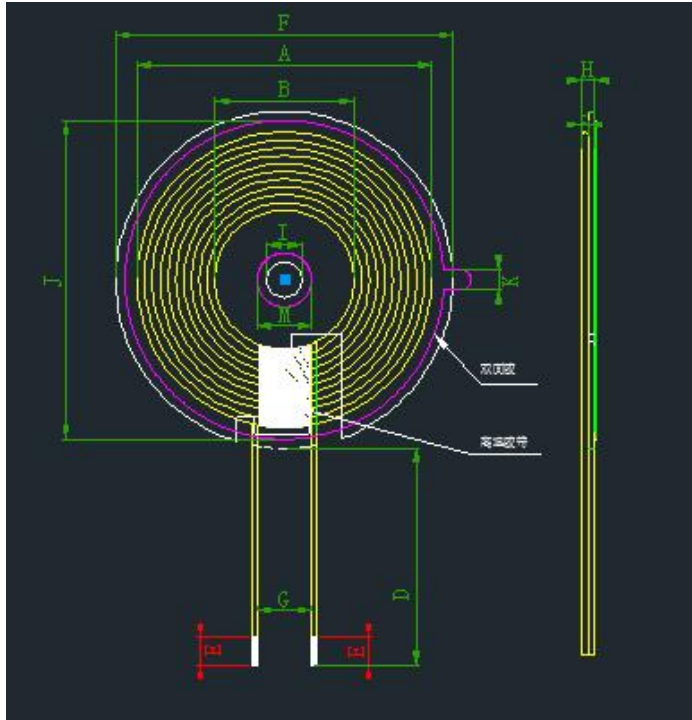

A	47±1.5
B	20.5±0.5
C	0.9 Max
D	50±3
E	4±2
F	50±0.5
G	8.0 ref
H	2.5 Max
I	5.3 ref
M	6.0 ref
J	49±1
K	5.0±1

注:

1. Cross coil out
2. Use 8mm(ref) high temperature adhesive tape to wrap the coil out position 1-2Ts
3. Coil sticks round magnetic sheet with slot/gum. magnetic sheet size: 50±0.5mm, bore size: 5.3mm, thickness: 0.9±1.5mm

2. SCHEMATIC DIAGRAM:

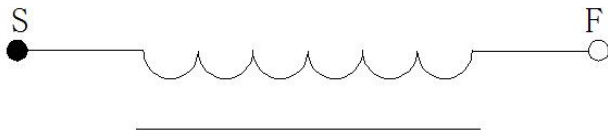

Gai n: 0dB

3. Winding Specification:

NO.	TERMINAL	WIRE	Turns	Winding Direction
1	S F	silk covered wire 0.08*105P	12Ts	CCW

4. ELECTRICAL CHARACTERISTICS:

TEMPERATURE:25±10°C, RELATIVE HUMIDITY:65±20%

NO.	ITEM	TERMINAL	SPECIFICATION	TEST FREQUENCY	TEST EQUIPMENTS
1	IND.	S-F	5.8uH ±20% single coil	100KHz/1.0V	LCZ METER 1062B
2	IND.	S-F	9.5uH ±10% magnetic sheet	100KHz/1.0V	LCZ METER 1062B
3	DCR	S-F	≤ 50m Ω	100KHz/1.0V	LCZ METER 502B
4	Q	S-F	≥ 75m Ω	100KHz/1.0V	LCZ METER 502B

PREPARED BY/DATE	CHECKED BY/DATE
------------------	-----------------

Meixian Xiang2022/05/20	GongLing Xiang2022/05/20
-------------------------	--------------------------