

# TEST REPORT

**Product Name** : 12MP VERSA CAM /SECURITY ACTION  
CAMERA  
**Model Number** : DVR944HD-BLK-WM  
**FCC ID** : 2AVLD-DVR944HD

**Prepared for** : BINSHINE TECH CO., LIMITED  
**Address** : Area A, Building B, Qinghu Science and Technology  
Park, Qingxian Road, Longhua New District, Shenzhen

**Prepared by** : EMTEK (DONGGUAN) CO., LTD.  
**Address** : -1&2/F., Building 2, Zone A, Zhongda Marine Biotechnology  
Reserch and Development Base, No.9, Xincheng Avenue,  
Songshanhu High-technology Industrial Development Zone,  
Dongguan, Guangdong, China

TEL: +86-0769-22807078

FAX: +86-0769-22807079

**Report Number** : ES200109052E  
**Date(s) of Tests** : January 09, 2020 to March 04, 2020  
**Date of issue** : March 04, 2020

**VERIFICATION OF COMPLIANCE**

Applicant:	BINSHINE TECH CO., LIMITED Area A, Building B, Qinghu Science and Technology Park, Qingxian Road, Longhua New District, Shenzhen
Factory:	Shenzhen Hongkexun Electronic Technology Co.,Ltd 2-3F, Building No.2, Xialingpai Industrial Zone, Dalang Street, Longhua, Shenzhen
Product Description:	12MP VERSA CAM /SECURITY ACTION CAMERA
Model Number:	DVR944HD-BLK-WM
Input Rating:	DC 3.7V from battery

**We hereby certify that:**

The above equipment was tested by EMTEK(SHENZHEN) CO., LTD. The test data, data evaluation, test procedures, and equipment configurations shown in this report were made in accordance with the procedures given in ANSI C63.10-2013 and the energy emitted by the sample EUT tested as described in this report is in compliance with conducted and radiated emission limits of FCC Rules Part 15.247(2017).

Date of Test : January 09, 2020 to March 04, 2020

*Loren Luo*

Prepared by : \_\_\_\_\_

Loren Luo /Editor

*Tim Dong*

Reviewer : \_\_\_\_\_

Tim Dong /Supervisor

*Lisa Wang*

Approved & Authorized Signer : \_\_\_\_\_

Lisa Wang/Manager

## Modified Information

Version	Summary	Revision Date	Report No.
Ver.1.0	Original Report	/	ES200109052E

## Table of Contents

<b>TEST REPORT .....</b>	<b>1</b>
<b>1. GENERAL INFORMATION .....</b>	<b>6</b>
1.1 PRODUCT DESCRIPTION .....	6
<b>2. SYSTEM TEST CONFIGURATION.....</b>	<b>7</b>
2.1 EUT CONFIGURATION.....	7
2.2 EUT EXERCISE.....	7
2.3 TEST PROCEDURE .....	7
2.4 CONFIGURATION OF TESTED SYSTEM.....	7
<b>3. DESCRIPTION OF TEST MODES.....</b>	<b>8</b>
<b>4. SUMMARY OF TEST RESULTS.....</b>	<b>9</b>
<b>5. TEST METHODOLOGY.....</b>	<b>9</b>
<b>6. TEST FACILITY.....</b>	<b>10</b>
<b>7. TEST SYSTEM UNCERTAINTY.....</b>	<b>11</b>
<b>8. CONDUCTED EMISSIONS TEST.....</b>	<b>12</b>
8.1 MEASUREMENT PROCEDURE .....	12
8.2 TEST SET-UP (BLOCK DIAGRAM OF CONFIGURATION) .....	12
8.3 MEASUREMENT EQUIPMENT USED .....	12
8.4 CONDUCTED EMISSION LIMIT .....	12
8.5 MEASUREMENT RESULT: .....	13
8.6 CONDUCTED MEASUREMENT PHOTOS: .....	16
<b>9. RADIATED EMISSION TEST.....</b>	<b>17</b>
9.1 MEASUREMENT PROCEDURE .....	17
9.2 TEST SET-UP (BLOCK DIAGRAM OF CONFIGURATION) .....	18
9.3 MEASUREMENT EQUIPMENT USED .....	19
9.4 RADIATED EMISSION LIMIT .....	20
9.5 MEASUREMENT RESULT .....	21
9.6 RADIATED MEASUREMENT PHOTOS:.....	26
<b>10. 6DB BANDWIDTH TEST.....</b>	<b>27</b>
10.1 MEASUREMENT PROCEDURE .....	27
10.2 TEST SET-UP (BLOCK DIAGRAM OF CONFIGURATION) .....	27
10.3 MEASUREMENT EQUIPMENT USED .....	27
10.4 MEASUREMENT RESULTS .....	27
<b>11. MAXIMUM PEAK OUTPUT POWER TEST.....</b>	<b>36</b>
11.1 MEASUREMENT PROCEDURE .....	36
11.2 TEST SET-UP (BLOCK DIAGRAM OF CONFIGURATION) .....	36
11.3 MEASUREMENT EQUIPMENT USED .....	36
11.4 PEAK POWER OUTPUT LIMIT .....	36
11.5 MEASUREMENT RESULTS .....	36
<b>12. BAND EDGE TEST .....</b>	<b>37</b>
12.1 MEASUREMENT PROCEDURE .....	37
12.2 TEST SET-UP (BLOCK DIAGRAM OF CONFIGURATION) .....	38
12.3 MEASUREMENT EQUIPMENT USED .....	38

12.4	MEASUREMENT RESULTS .....	38
<b>13.</b>	<b>MAXIUMUM POWER SPECTRAL DENSITY .....</b>	<b>44</b>
13.1	TEST EQUIPMENT .....	44
13.2	MEASURING INSTRUMENTS AND SETTING.....	44
13.3	TEST PROCEDURES.....	44
13.4	BLOCK DIAGRAM OF TEST SETUP .....	44
13.5	LIMIT.....	45
13.6	TEST RESULT .....	45
<b>14.</b>	<b>ANTENNA PORT EMISSION .....</b>	<b>53</b>
14.1	TEST EQUIPMENT .....	53
14.2	MEASURING INSTRUMENTS AND SETTING.....	53
14.3	TEST PROCEDURES.....	53
14.4	BLOCK DIAGRAM OF TEST SETUP.....	53
14.5	TEST RESULT .....	53
<b>15.</b>	<b>ANTENNA APPLICATION.....</b>	<b>60</b>
15.1	ANTENNA REQUIREMENT.....	60
15.2	RESULT .....	60

APPENDIX I (PHOTOS OF EUT)(13PAGES)

## 1. General Information

### 1.1 Product Description

Characteristics	Description
Product Name	12MP VERSA CAM /SECURITY ACTION CAMERA
Model number	DVR944HD-BLK-WM
Power Supply	DC 3.7V from battery
Modulation	802.11b: DSSS(DBPSK/DQPSK/CCK) 802.11g/n: OFDM(BPSK/QPSK/16QAM/64QAM)
Operating Frequency Range	2412-2462MHz for 802.11b/g/n(HT20) 2422-2452MHz for 802.11n(HT40)
Number of Channels	11 for 20MHz bandwidth; 7 for 40MHz bandwidth
Transmit Power Max	802.11b: 15.34dBm 802.11g: 14.16 dBm 802.11n(HT20): 10.27Bm 802.11n(HT40): 8.36dBm
Antenna Type	PIFA Antenna
Antenna Gain	2 dBi

**Note:** for more details, please refer to the User's manual of the EUT.

## 2. System Test Configuration

### 2.1 EUT Configuration

The EUT configuration for testing is installed on RF field strength measurement to meet the Commissions requirement and operating in a manner which intends to maximize its emission characteristics in a continuous normal application.

### 2.2 EUT Exercise

The Transmitter was operated in the normal operating mode. The TX frequency was fixed which was for the purpose of the measurements.

### 2.3 Test Procedure

#### 2.3.1 Conducted Emissions

The EUT is a placed on as turn table which is 0.8 m above ground plane. According to the requirements in Section 13.1.4.1 of ANSI C63.10-2013 Conducted emissions from the EUT measured in the frequency range between 0.15 MHz and 30 MHz using CISPR Quasi-Peak and average detector mode.

#### 2.3.2 Radiated Emissions

The EUT is a placed on as turn table which is 0.8 m above ground plane. The turn table shall rotate 360 degrees to determine the position of maximum emission level. EUT is set 3m away from the receiving antenna which varied from 1m to 4m to find out the highest emission. And also, each emission was to be maximized by changing the polarization of receiving antenna both horizontal and vertical. In order to find out the max. Emission, the relative positions of this hand-held transmitter (EUT) was rotated through three orthogonal axes according to the requirements in Section 13.1.4.1 of ANSI C63.10-2013.

### 2.4 Configuration of Tested System

**Fig. 2-1 Configuration of Tested System**

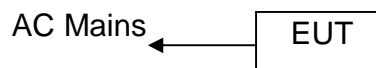

**Table 2-1 Equipment Used in Tested System**

Item	Equipment	Trademark	Model No.	FCC ID	Note
1.	N/A	N/A	Z5	2AVLD-DVR944HD	EUT

**Note:**

- (1) Unless otherwise denoted as EUT in 『Remark』 column, device(s) used in tested system is a support equipment.

### 3. Description of Test Modes

The EUT has been tested under its typical operating condition.

The EUT configuration for testing is installed on RF field strength measurement to meet the Commissions requirement and operating in a manner which intends to maximize its emission characteristics in a continuous normal application.

The Transmitter was operated in the normal operating mode. The TX frequency was fixed which was for the purpose of the measurements.

Test of channel included the lowest and middle and highest frequency to perform the test, then record on this report.

Those data rates (802.11b: 1 Mbps; 802.11g: 6 Mbps; 802.11n (HT20 ): MCS0; 802.11n (HT40 ): MCS0) were used for all test.

Pre-defined engineering program for regulatory testing used to control the EUT for staying in continuous transmitting and receiving mode is programmed.

Frequency and Channel list for 802.11 b/g/n (HT20):

Channel	Frequency (MHz)	Channel	Frequency (MHz)	Channel	Frequency (MHz)
1	2412	5	2432	9	2452
2	2417	6	2437	10	2457
3	2422	7	2442	11	2462
4	2427	8	2447		

Frequency and Channel list for 802.11 n (HT40):

Channel	Frequency (MHz)	Channel	Frequency (MHz)	Channel	Frequency (MHz)
3	2422	5	2432	8	2447
4	2427	6	2437	9	2452
		7	2442		

Test Frequency and Channel for 802.11 b/g/n (HT20):

Lowest Frequency		Middle Frequency		Highest Frequency	
Channel	Frequency (MHz)	Channel	Frequency (MHz)	Channel	Frequency (MHz)
1	2412	6	2437	11	2462

Test Frequency and channel for 802.11 n (HT40):

Lowest Frequency		Middle Frequency		Highest Frequency	
Channel	Frequency (MHz)	Channel	Frequency (MHz)	Channel	Frequency (MHz)
3	2422	6	2437	9	2452



## 4. Summary of Test Results

FCC Rules	Description Of Test	Result
§15.247(a)(2)	6dB bandwidth	Pass
§15.247(b)(3)	Max Peak output Power test	Pass
§15.247(e)	Power density	Pass
§15.247(d)	Band edge test	Pass
§15.207	AC Power Conducted Emission	Pass
§15.247(d), §15.209	Radiated Emission	Pass
§15.247(d)	Antenna Port Emission	Pass
§15.247(b)&§15.203	Antenna Application	Pass

### RELATED SUBMITTAL(S) / GRANT(S):

This submittal(s) (test report) is intended for FCC ID: 2AVLD-DVR944HD filing to comply with Section 15.247 of the FCC Part 15, Subpart C Rules.

The system is compliance with Subpart B is authorized under a DOC procedure

## 5. Test Methodology

According to its specifications, the EUT must comply with the requirements of the following standards:

FCC 47 CFR Part 2, Subpart J

FCC 47 CFR Part 15, Subpart C

FCC KDB 558074 DTS D01 Meas. Guidance v05r02.

FCC KDB 662911 D01 Multiple Transmitter Output v01

## 6. Test Facility

### Site Description

EMC Lab : Accredited by CNAS, 2016.10.24  
The certificate is valid until 2022.10.28  
The Laboratory has been assessed and proved to be in compliance with CNAS-CL01:2006 (identical to ISO/IEC 17025:2005)  
The Certificate Registration Number is L2291.

Accredited by TUV Rheinland Shenzhen 2016.5.19  
The Laboratory has been assessed according to the requirements ISO/IEC 17025.

Accredited by FCC, August 03, 2017  
Designation Number: CN1204  
Test Firm Registration Number: 882943

Accredited by Industry Canada, November 24, 2015  
The Certificate Registration Number is 4480A.

Accredited by A2LA, July 31, 2017  
The Certificate Number is 4321.01.

Name of Firm : EMTEK(SHENZHEN) CO., LTD.  
Bldg 69, Majialong Industry Zone, Nanshan District, Shenzhen, Guangdong, China.

## 7. TEST SYSTEM UNCERTAINTY

The following measurement uncertainty levels have been estimated for tests performed on the apparatus:

Parameter	Uncertainty
Radio Frequency	$\pm 1 \times 10^{-5}$
Maximum Peak Output Power Test	$\pm 1.0\text{dB}$
Conducted Emissions Test	$\pm 2.0\text{dB}$
Radiated Emission Test	$\pm 2.0\text{dB}$
Power Density	$\pm 2.0\text{dB}$
Occupied Bandwidth Test	$\pm 1.0\text{dB}$
Band Edge Test	$\pm 3\text{dB}$
All emission, radiated	$\pm 3\text{dB}$
Antenna Port Emission	$\pm 3\text{dB}$
Temperature	$\pm 0.5^\circ\text{C}$
Humidity	$\pm 3\%$

Measurement Uncertainty for a level of Confidence of 95%

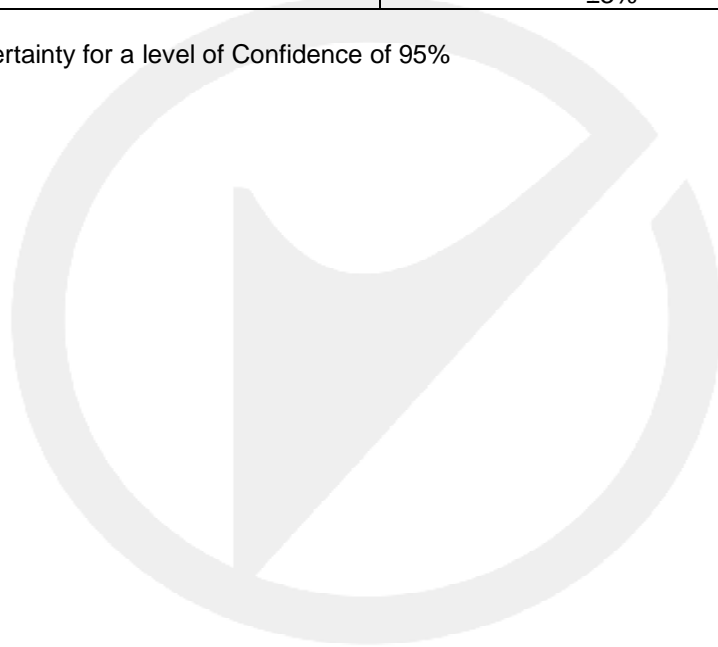

## 8. Conducted Emissions Test

### 8.1 Measurement Procedure

1. The EUT was placed on a table which is 0.8m above ground plane.
2. Maximum procedure was performed on the six highest emissions to ensure EUT compliance.
3. Repeat above procedures until all frequency measured were complete.

### 8.2 Test SET-UP (Block Diagram of Configuration)

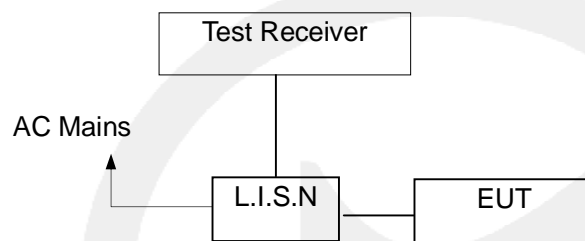

### 8.3 Measurement Equipment Used

Conducted Emission Test Site					
EQUIPMENT TYPE	MFR	MODEL NUMBER	SERIAL NUMBER	Last Cal.	Due date
Test Receiver	Rohde & Schwarz	ESCS30	100018	05/23/2019	05/22/2020
L.I.S.N	Rohde & Schwarz	ENV216	100017	05/23/2019	05/22/2020
RF Switching Unit	CDS	RSU-M2	38401	05/23/2019	05/22/2020
Coaxial Cable	CDS	79254	46107086	05/23/2019	05/22/2020

### 8.4 Conducted Emission Limit

Conducted Emission Frequency(MHz)	Quasi-peak	Average
0.15-0.5	66-56	56-46
0.5-5.0	56	46
5.0-30.0	60	50

- Note:** 1. The lower limit shall apply at the transition frequencies  
 2. The limit decreases in line with the logarithm of the frequency in the range of 0.15 to 0.50MHz.

### 8.5 Measurement Result:

Operation Mode:	TX	Test Date :	December 17, 2019
Frequency Range:	0.15MHz~30MHz	Temperature :	28℃
Test Result:	PASS	Humidity :	65 %
Test By:	Loren		

Pass.

Conducted emission at both 120V & 240V, and emission at 120V represents the worst case. All the modulation modes were tested the data of the worst mode (GFSK TX 2402MHz) are recorded in the following pages and the others modulation methods do not exceed the limits.

Please refer to the following data.

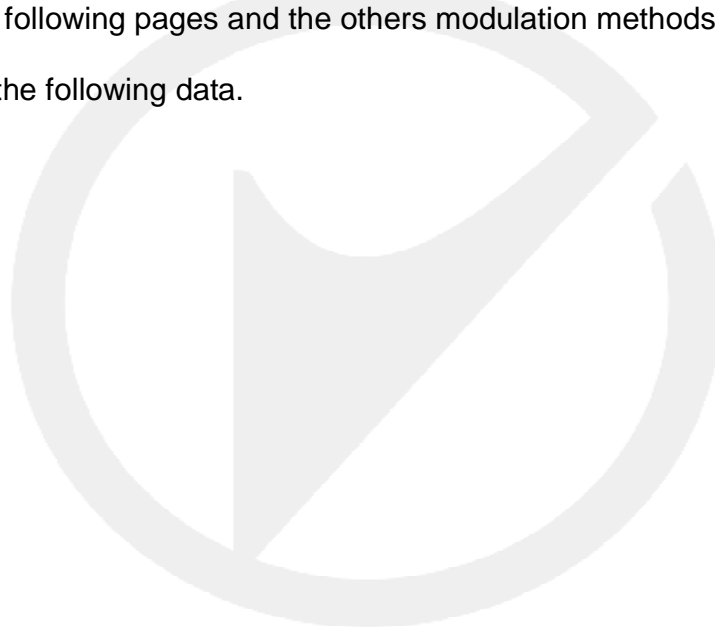

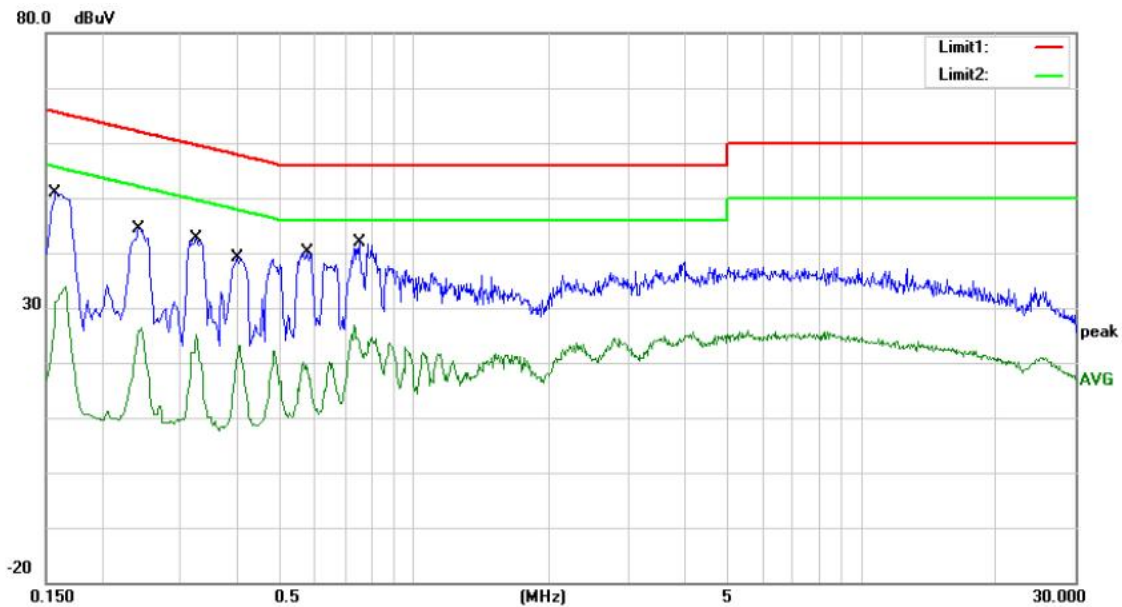

Site: site #1  
 Limit: (CE)FCC PART 15 C\_QP  
 Mode: Wifi TX 2412  
 Note:

Phase: **N**  
 Power: AC 120V/60Hz

Temperature: 25  
 Humidity: 55 %

No.	Mk.	Freq. MHz	Reading Level dBuV	Correct Factor dB	Measure- ment dBuV	Limit dBuV	Over dB	Detector	Comment
1		0.1580	40.79	10.01	50.80	65.57	-14.77	QP	
2		0.1580	23.98	10.01	33.99	55.57	-21.58	AVG	
3		0.2420	34.43	10.05	44.48	62.03	-17.55	QP	
4		0.2420	16.42	10.05	26.47	52.03	-25.56	AVG	
5		0.3260	32.50	10.10	42.60	59.55	-16.95	QP	
6		0.3260	14.98	10.10	25.08	49.55	-24.47	AVG	
7		0.4020	29.00	10.13	39.13	57.81	-18.68	QP	
8		0.4020	13.01	10.13	23.14	47.81	-24.67	AVG	
9		0.5780	29.89	10.18	40.07	56.00	-15.93	QP	
10		0.5780	12.05	10.18	22.23	46.00	-23.77	AVG	
11	*	0.7540	31.65	10.18	41.83	56.00	-14.17	QP	
12		0.7540	16.70	10.18	26.88	46.00	-19.12	AVG	

\*:Maximum data    x:Over limit    f:over margin    Comment: Factor build in receiver.    Operator: Lian

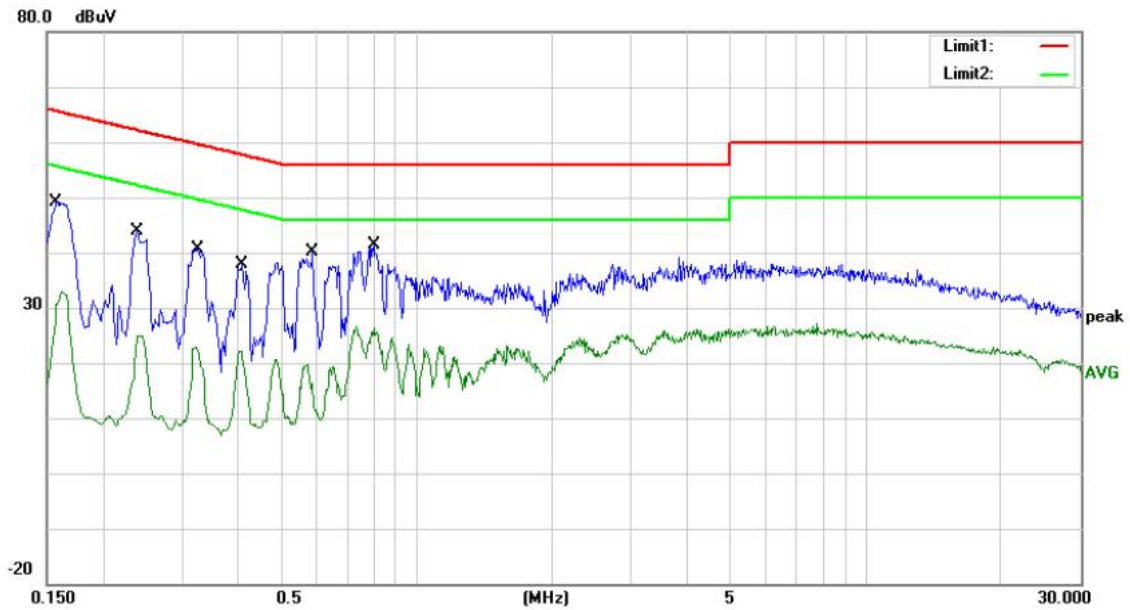

Site site #1 Phase: **L1** Temperature: 25  
 Limit: (CE)FCC PART 15 C\_QP Power: AC 120V/60Hz Humidity: 55 %  
 Mode: Wifi TX 2412  
 Note:

No.	Mk.	Freq. MHz	Reading Level dBuV	Correct Factor dB	Measure- ment dBuV	Limit dBuV	Over dB	Detector	Comment
1		0.1580	39.18	10.01	49.19	65.57	-16.38	QP	
2		0.1580	22.79	10.01	32.80	55.57	-22.77	AVG	
3		0.2380	33.92	10.05	43.97	62.17	-18.20	QP	
4		0.2380	14.86	10.05	24.91	52.17	-27.26	AVG	
5		0.3260	30.64	10.10	40.74	59.55	-18.81	QP	
6		0.3260	12.83	10.10	22.93	49.55	-26.62	AVG	
7		0.4100	27.68	10.14	37.82	57.65	-19.83	QP	
8		0.4100	12.02	10.14	22.16	47.65	-25.49	AVG	
9		0.5860	29.98	10.18	40.16	56.00	-15.84	QP	
10		0.5860	10.57	10.18	20.75	46.00	-25.25	AVG	
11	*	0.8020	31.09	10.18	41.27	56.00	-14.73	QP	
12		0.8020	16.48	10.18	26.66	46.00	-19.34	AVG	

\*:Maximum data x:Over limit !:over margin Comment: Factor build in receiver. Operator: Lian

### 8.6 Conducted Measurement Photos:





## 9. Radiated Emission Test

### 9.1 Measurement Procedure

1. Below 1000MHz, The EUT was placed on a turn table which is 0.8m above ground plane, And above 1000MHz, The EUT was placed on a styrofoam table which is 1.5m above ground plane.
2. Maximum procedure was performed on the six highest emissions to ensure EUT compliance.
3. And also, each emission was to be maximized by changing the polarization of receiving antenna both horizontal and vertical.
4. Repeat above procedures until all frequency measured was complete.

When spectrum scanned from 30MHz to 1GHz setting resolution bandwidth 120KHz and video bandwidth 300KHz:

EMI Test Receiver	Setting
Attenuation	Auto
RBW	120KHz
VBW	300KHz
Detector	QP
Trace	Max hold

When spectrum scanned above 1GHz setting resolution bandwidth 1MHz, video bandwidth 3MHz:

EMI Test Receiver	Setting
Attenuation	Auto
RBW	1MHz
VBW	3MHz
Detector	Peak
Trace	Max hold

When spectrum scanned above 1GHz setting resolution bandwidth 1MHz, video bandwidth 10Hz:

EMI Test Receiver	Setting
Attenuation	Auto
RBW	1MHz
VBW	10Hz
Detector	Peak
Trace	Max hold

## 9.2 Test SET-UP (Block Diagram of Configuration)

(A) Radiated Emission Test Set-Up, Frequency Below 30MHz

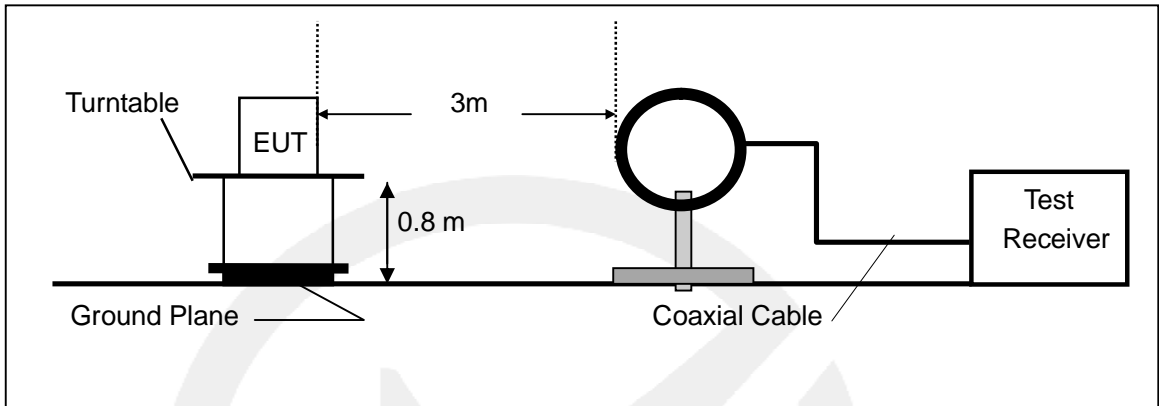

(B) Radiated Emission Test Set-Up, Frequency Below 1000MHz

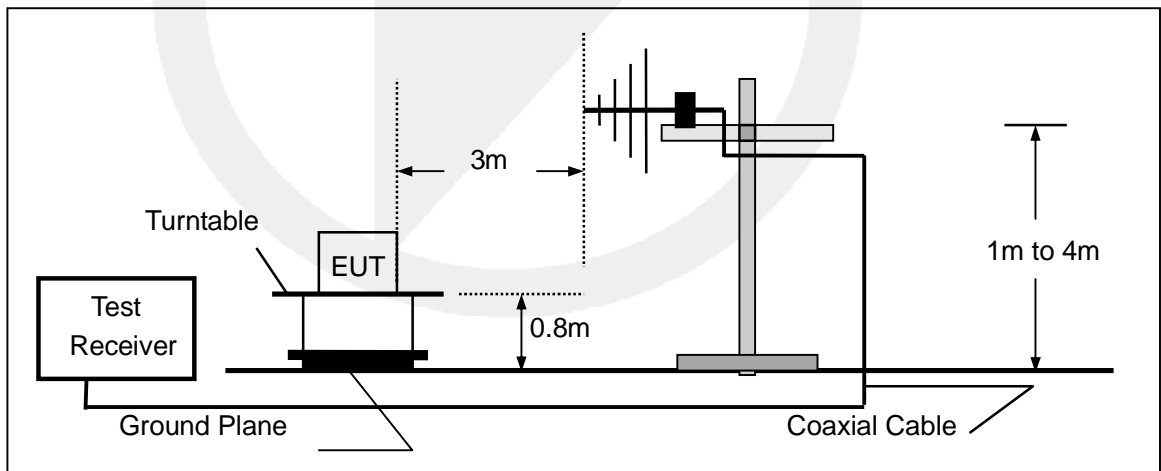

(C) Radiated Emission Test Set-Up, Frequency above 1000MHz

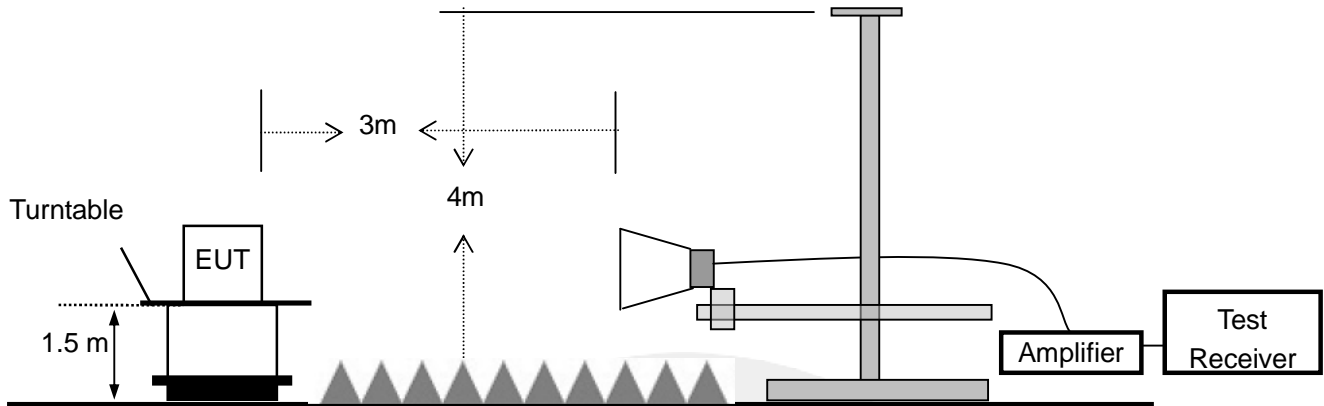

**9.3 Measurement Equipment Used**

Item	Equipment	Manufacturer	Model No.	Serial No.	Last Cal.	Cal. Interval
1.	Test Receiver	Rohde & Schwarz	ESCI	1166.5950.03	05/23/2019	1 Year
2.	Bilog Antenna	Schwarzbeck	VULB9163	000141	05/23/2019	1 Year
3.	Power Amplifier	CDS	RSU-M352	818	05/23/2019	1 Year
4.	Power Amplifier	HP	8447F	OPT H64	05/23/2019	1 Year
5.	Color Monitor	SUNSP0	SP-140A	N/A	05/23/2019	1 Year
6.	Single Line Filter	JIANLI	XL-3	N/A	05/23/2019	1 Year
7.	Single Phase Power Line Filter	JIANLI	DL-2X100B	N/A	05/23/2019	1 Year
8.	3 Phase Power Line Filter	JIANLI	DL-4X100B	N/A	05/23/2019	1 Year
9.	DC Power Filter	JIANLI	DL-2X50B	N/A	05/23/2019	1 Year
10.	Cable	Schwarzbeck	PLF-100	549489	05/23/2019	1 Year
11.	Cable	Rosenberger	CIL02	A0783566	05/23/2019	1 Year
12.	Cable	Rosenberger	RG 233/U	525178	05/23/2019	1 Year
13.	Signal Analyzer	Rohde & Schwarz	FSV30	103040	05/23/2019	1 Year
14.	Horn Antenna	Schwarzbeck	BBHA9120D	9120D-1272	05/23/2019	1 Year
15.	Power Amplifier	LUNAR EM	LNA1G18-40	J1010000008 1	05/23/2019	1 Year
16.	Cable	H+S	CBL-26	N/A	05/23/2019	1 Year
17.	Cable	H+S	CBL-26	N/A	05/23/2019	1 Year
18.	Cable	H+S	CBL-26	N/A	05/23/2019	1 Year

#### 9.4 Radiated Emission Limit

The emissions from an intentional radiator shall not exceed the field strength levels specified in the following table 15.209(a):

Frequencies (MHz)	Field Strength (micorvolts/meter)	Measurement Distance (meters)
0.009~0.490	2400/F(KHz)	300
0.490~1.705	24000/F(KHz)	30
1.705~30.0	30	30
30~88	100	3
88~216	150	3
216~960	200	3
Above 960	500	3

#### Restricted bands of operation

MHz	MHz	MHz	GHz
0.090 - 0.110	16.42 - 16.423	399.9 - 410	4.5 - 5.15
<sup>1</sup> 0.495 - 0.505	16.69475 - 16.69525	608 - 614	5.35 - 5.46
2.1735 - 2.1905	16.80425 - 16.80475	960 - 1240	7.25 - 7.75
4.125 - 4.128	25.5 - 25.67	1300 - 1427	8.025 - 8.5
4.17725 - 4.17775	37.5 - 38.25	1435 - 1626.5	9.0 - 9.2
4.20725 - 4.20775	73 - 74.6	1645.5 - 1646.5	9.3 - 9.5
6.215 - 6.218	74.8 - 75.2	1660 - 1710	10.6 - 12.7
6.26775 - 6.26825	108 - 121.94	1718.8 - 1722.2	13.25 - 13.4
6.31175 - 6.31225	123 - 138	2200 - 2300	14.47 - 14.5
8.291 - 8.294	149.9 - 150.05	2310 - 2390	15.35 - 16.2
8.362 - 8.366	156.52475 - 156.52525	2483.5 - 2500	17.7 - 21.4
8.37625 - 8.38675	156.7 - 156.9	2690 - 2900	22.01 - 23.12
8.41425 - 8.41475	162.0125 - 167.17	3260 - 3267	23.6 - 24.0
12.29 - 12.293	167.72 - 173.2	3332 - 3339	31.2 - 31.8
12.51975 - 12.52025	240 - 285	3345.8 - 3358	36.43 - 36.5
12.57675 - 12.57725	322 - 335.4	3600 - 4400	( <sup>2</sup> )

- Remark 1. Emission level in dBuV/m=20 log (uV/m)
- : 2. Measurement was performed at an antenna to the closed point of EUT distance of meters.
3. Only spurious frequency is permitted to locate within the Restricted Bands specified in provision of x 15.205, and the emissions located in restricted bands also comply with 15.209 limit.

## 9.5 Measurement Result

### Below 30MHz:

All the modulation modes were tested the data of the test mode are recorded in the following pages.

Operation Mode:	TX Mode	Test Date :	February 17, 2020
Frequency Range:	9KHz~30MHz	Temperature :	28℃
Test Result:	PASS	Humidity :	60 %
Measured Distance:	3m	Test By:	John

Freq. (MHz)	Ant.Pol. H/V	Emission Level (dBuV/m)	Limit 3m (dBuV/m)	Over (dB)
--	--	--	--	--

Note: the amplitude of spurious emission that is attenuated by more than 20dB below the permissible limit has no need to be reported.

Distance extrapolation factor =  $40\log(\text{Specific distance}/\text{test distance})$  (dB);

Limit line = Specific limits(dBuV) + distance extrapolation factor.

### Below 1000MHz:

All the modulation modes were tested the data of the worst mode (TX 802.11b 2462MHz) are recorded in the following pages and the others modulation methods do not exceed the limits.

Please refer to the following test plots:

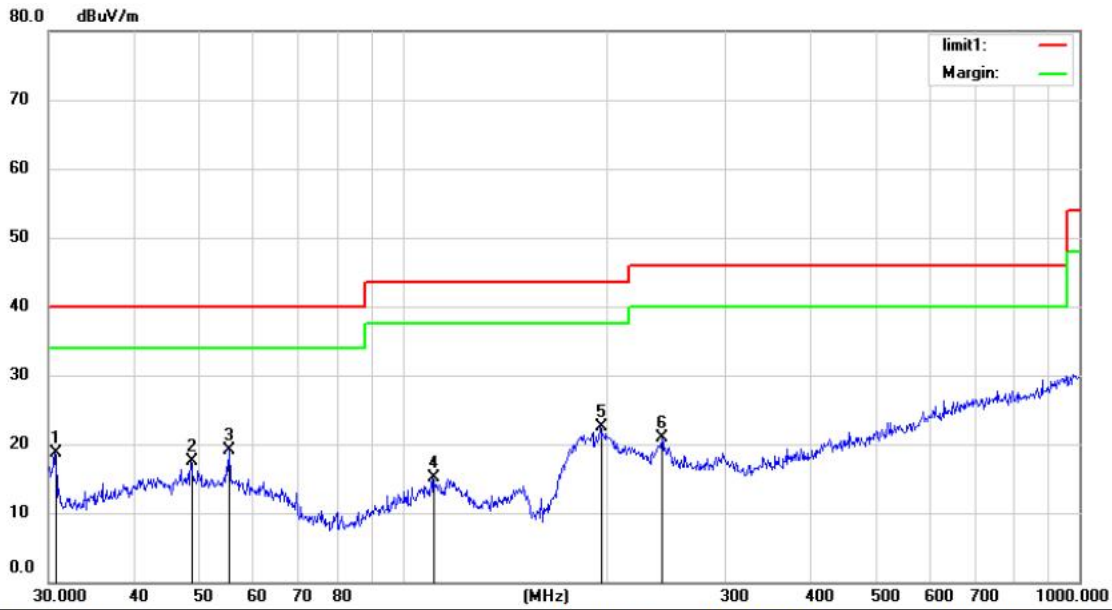

Site Chamber #1 Polarization: **Horizontal** Temperature: 26  
 Limit: (RE)FCC PART 15 C 3m Power: DC 3.7V Humidity: 55 %  
 Mode:WIFI TX2412  
 Note:

No.	Mk.	Freq. MHz	Reading Level dBuV	Correct Factor dB	Measure- ment dBuV/m	Limit dBuV/m	Over dB	Antenna Height cm	Table Degree degree	Comment
1		30.6380	37.59	-18.84	18.75	40.00	-21.25	QP		
2		48.6720	33.10	-15.65	17.45	40.00	-22.55	QP		
3	*	55.4147	35.20	-16.00	19.20	40.00	-20.80	QP		
4		110.9571	33.57	-18.54	15.03	43.50	-28.47	QP		
5		195.8220	40.05	-17.64	22.41	43.50	-21.09	QP		
6		241.6763	36.67	-15.69	20.98	46.00	-25.02	QP		

\*:Maximum data x:Over limit l:over margin

Operator: HU

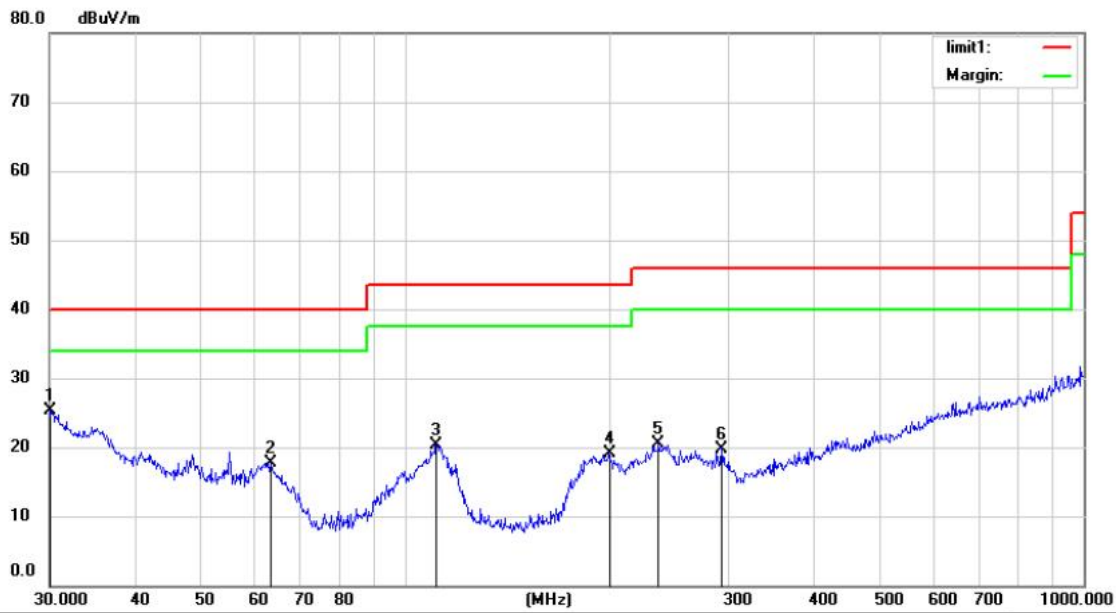

Site Chamber #1 Polarization: **Vertical** Temperature: 26  
 Limit: (RE)FCC PART 15 C 3m Power: DC 3.7V Humidity: 55 %  
 Mode:WIFI TX2412  
 Note:

No.	Mk.	Freq.	Reading Level	Correct Factor	Measurement	Limit	Over	Antenna Height	Table Degree	
		MHz	dBuV	dB	dBuV/m	dBuV/m	dB	cm	degree	Comment
1	*	30.0000	44.08	-18.76	25.32	40.00	-14.68			QP
2		63.5356	35.24	-17.55	17.69	40.00	-22.31			QP
3		111.3468	38.93	-18.60	20.33	43.50	-23.17			QP
4		199.9856	36.44	-17.25	19.19	43.50	-24.31			QP
5		236.6447	36.54	-15.98	20.56	46.00	-25.44			QP
6		293.0842	33.72	-13.92	19.80	46.00	-26.20			QP

\*:Maximum data x:Over limit l:over margin

Operator: HU

**Above 1000MHz:**

Operation Mode: 802.11b Lowest Test Date : February 17, 2020  
 Test Voltage: DC 3.7V From Battery Test by: John

Freq. (MHz)	Ant. Pol. H/V	Reading Level(dBuV/m)		Correct Factor dB	Emission Level(dBuV/m)		Limit 3m		Margin(dB)	
		PK	AV		PK	AV	PK	AV	PK	AV
4824	V	95.03	73.04	-32.15	62.88	40.89	74	54	-11.12	-13.11
7236	V	96.62	76.96	-37.58	59.04	39.38	74	54	-14.96	-14.62
9648	V	96.57	73.50	-39.54	57.03	33.96	74	54	-16.97	-20.04
12060	V	91.68	71.27	-40.11	51.57	31.16	74	54	-22.43	-22.84
14472	V	94.04	70.58	-40.98	53.06	29.60	74	54	-20.94	-24.40
16884	V	98.24	76.49	-40.07	58.17	36.42	74	54	-15.83	-17.58
4824	H	96.69	73.73	-31.46	65.23	42.27	74	54	-8.77	-11.73
7236	H	98.08	70.13	-35.68	62.40	34.45	74	54	-11.60	-19.55
9648	H	93.54	76.50	-38.29	55.25	38.21	74	54	-18.75	-15.79
12060	H	93.90	72.01	-39.16	54.74	32.85	74	54	-19.26	-21.15
14472	H	94.67	71.33	-42.13	52.54	29.20	74	54	-21.46	-24.80
16884	H	95.33	76.85	-39.64	55.69	37.21	74	54	-18.31	-16.79

Operation Mode: 802.11b Middle Test Date : February 17, 2020  
 Test Voltage: DC 3.7V From Battery Test by: Loren

Freq. (MHz)	Ant. Pol. H/V	Reading Level(dBuV/m)		Correct Factor dB	Emission Level(dBuV/m)		Limit 3m(dBuV/m)		Margin(dB)	
		PK	AV		PK	AV	PK	AV	PK	AV
4874	V	94.09	72.05	-31.25	62.84	40.8	74	54	-11.16	-13.20
7311	V	93.87	74.29	-37.46	56.41	36.83	74	54	-17.59	-17.17
9748	V	97.09	75.15	-39.62	57.47	35.53	74	54	-16.53	-18.47
12185	V	97.18	75.45	-40.27	56.91	35.18	74	54	-17.09	-18.82
14622	V	95.07	74.49	-41.57	53.5	32.92	74	54	-20.50	-21.08
17059	V	98.73	72.12	-41.11	57.62	31.01	74	54	-16.38	-22.99
4874	H	98.48	74.75	-31.59	66.89	43.16	74	54	-7.11	-10.84
7311	H	98.86	70.16	-35.67	63.19	34.49	74	54	-10.81	-19.51
9748	H	97.58	75.30	-39.27	58.31	36.03	74	54	-15.69	-17.97
12185	H	91.06	71.52	-39.14	51.92	32.38	74	54	-22.08	-21.62
14622	H	97.75	75.37	-42.57	55.18	32.8	74	54	-18.82	-21.20
17059	H	93.23	71.26	-41.52	51.71	29.74	74	54	-22.29	-24.26



Operation Mode: 802.11b Highest

Test Date : February 17, 2020

Test Voltage: DC 3.7V From Battery

Test by: Loren

Freq. (MHz)	Ant. Pol. H/V	Reading Level(dBuV/m)		Correct Factor dB	Emission Level(dBuV/m)		Limit 3m(dBuV/m)		Over(dB)	
		PK	AV		PK	AV	PK	AV	PK	AV
4924	V	96.35	74.54	-31.99	64.36	42.55	74	54	-9.64	-11.45
7386	V	91.04	73.49	-37.12	53.92	36.37	74	54	-20.08	-17.63
9848	V	97.33	73.08	-39.03	58.3	34.05	74	54	-15.70	-19.95
12310	V	95.48	75.09	-40.09	55.39	35	74	54	-18.61	-19.00
14772	V	97.60	72.26	-41.15	56.45	31.11	74	54	-17.55	-22.89
17234	V	97.80	75.33	-41.37	56.43	33.96	74	54	-17.57	-20.04
4924	H	92.68	75.93	-31.19	61.49	44.74	74	54	-12.51	-9.26
7386	H	93.72	70.63	-36.54	57.18	34.09	74	54	-16.82	-19.91
9848	H	95.04	72.53	-38.64	56.4	33.89	74	54	-17.60	-20.11
12310	H	91.83	70.12	-39.67	52.16	30.45	74	54	-21.84	-23.55
14772	H	92.03	70.94	-42.17	49.86	28.77	74	54	-24.14	-25.23
17234	H	95.20	75.71	-41.56	53.64	34.15	74	54	-20.36	-19.85

**All emissions not reported were more than 20dB below the specified limit or in the noise floor.**

- Note:**
- (1) All Readings are Peak Value and AV.
  - (2) Emission Level= Reading Level+Probe Factor +Cable Loss.
  - (3) Data of measurement within this frequency range shown “ – ” in the table above means the reading of emissions are attenuated more than 20dB below the permissible limits or the field strength is too small to be measured.

### 9.6 Radiated Measurement Photos:

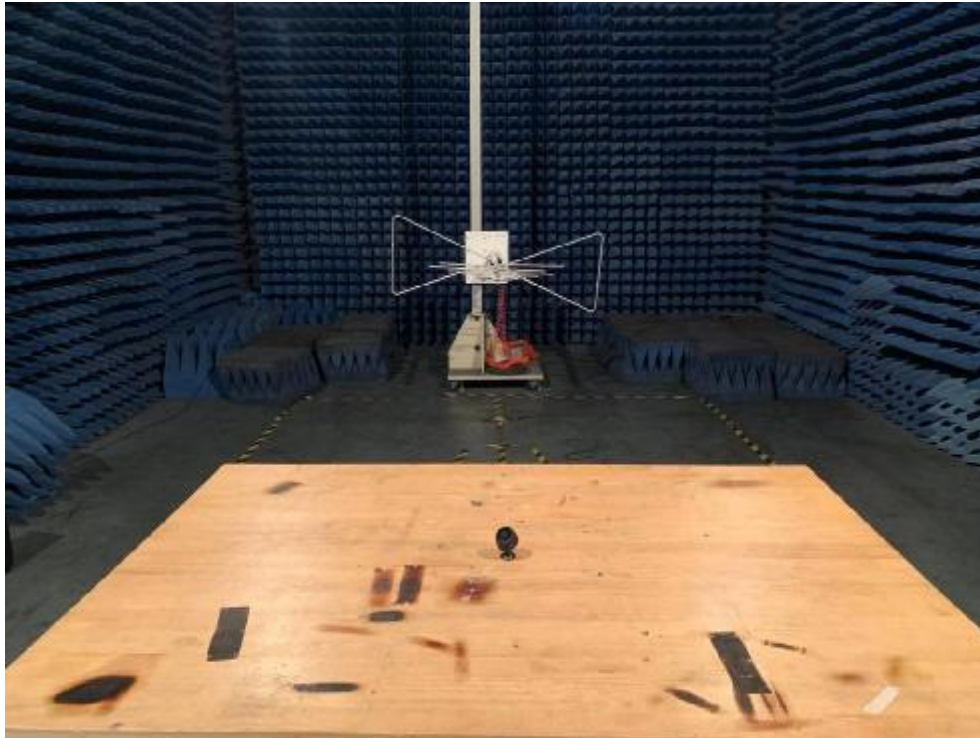

## 10. 6dB Bandwidth Test

### 10.1 Measurement Procedure

The EUT was operating in IEEE 802.11b, 802.11g, 802.11n(HT20), 802.11n(HT40) mode or could be controlled its channel. Printed out the test result from the spectrum by hard copy function.

1. Set resolution bandwidth (RBW) = 100 kHz.
2. Set the video bandwidth (VBW)  $\geq 3 \times$  RBW.
3. Detector = Peak.
4. Trace mode = max hold.
5. Sweep = auto couple.
6. Allow the trace to stabilize.
7. Measure the maximum width of the emission that is constrained by the frequencies associated with the two outermost amplitude points (upper and lower frequency) that are attenuated by 6 dB relative to the maximum level measured in the fundamental emission.

### 10.2 Test SET-UP (Block Diagram of Configuration)

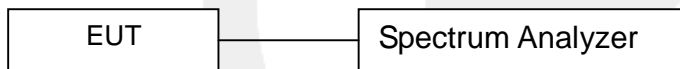

### 10.3 Measurement Equipment Used

EQUIPMENT TYPE	MFR	MODEL NUMBER	SERIAL NUMBER	LAST CAL.	CAL DUE.
Spectrum Analyzer	Agilent	FSV30	1321.3008K	05/23/2019	05/22/2020

### 10.4 Measurement Results

6 Bandwidth Test Data Chart:

Refer to attached data chart.

Spectrum Detector: PK                      Test Date : February 17, 2020  
 Test By: Yaping Shen                      Temperature : 28°C  
 Humidity : 60%

IEEE 802.11b			
Channel frequency (MHz)	Measurement level (KHz)	Required Limit (KHz)	Result
2412	10057	>500	Pass
2437	9578	>500	
2462	9583	>500	



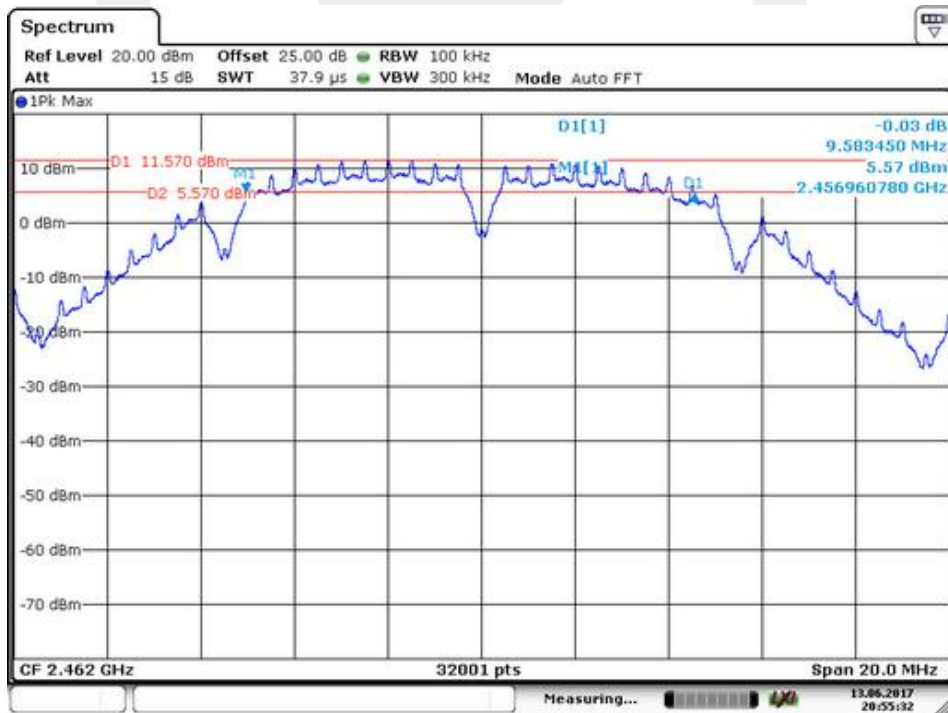
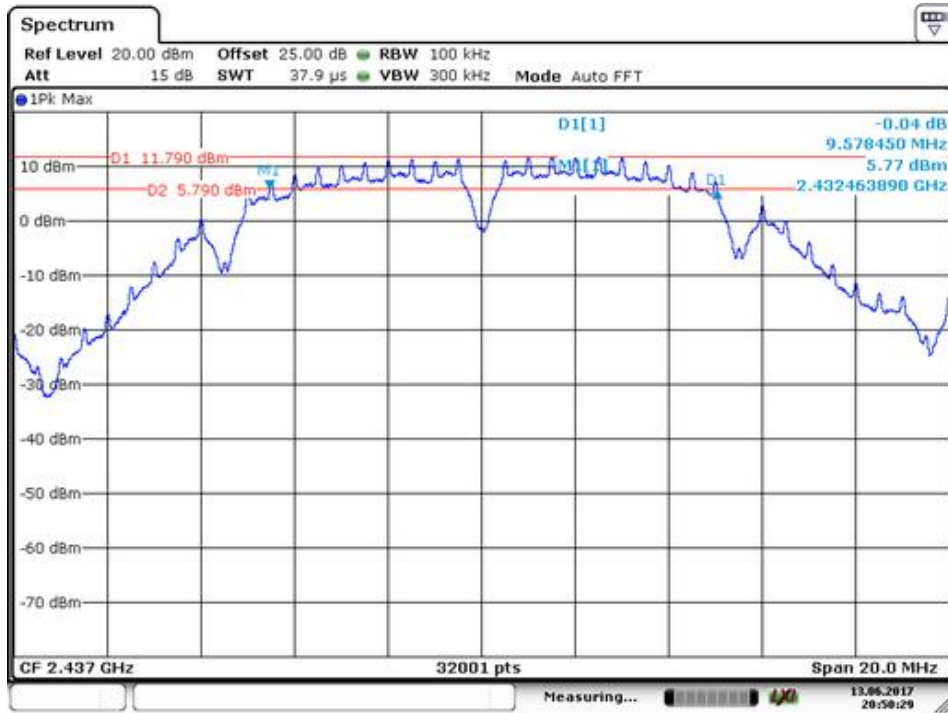

IEEE 802.11g			
Channel frequency (MHz)	Measurement level (KHz)	Required Limit (KHz)	Result
2412	16443	>500	Pass
2437	16413	>500	
2462	16406	>500	

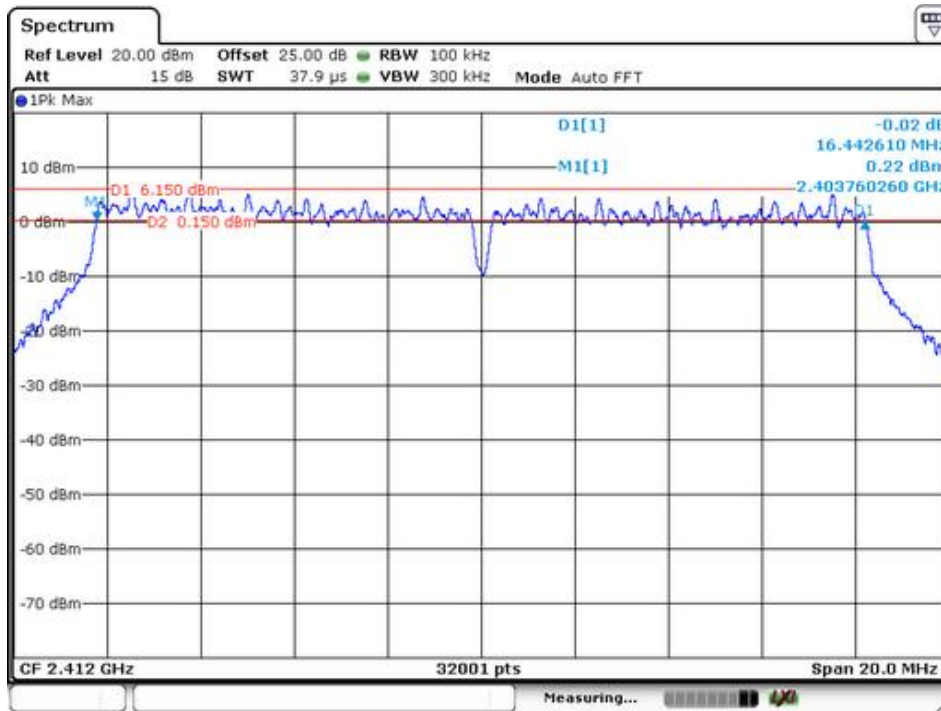

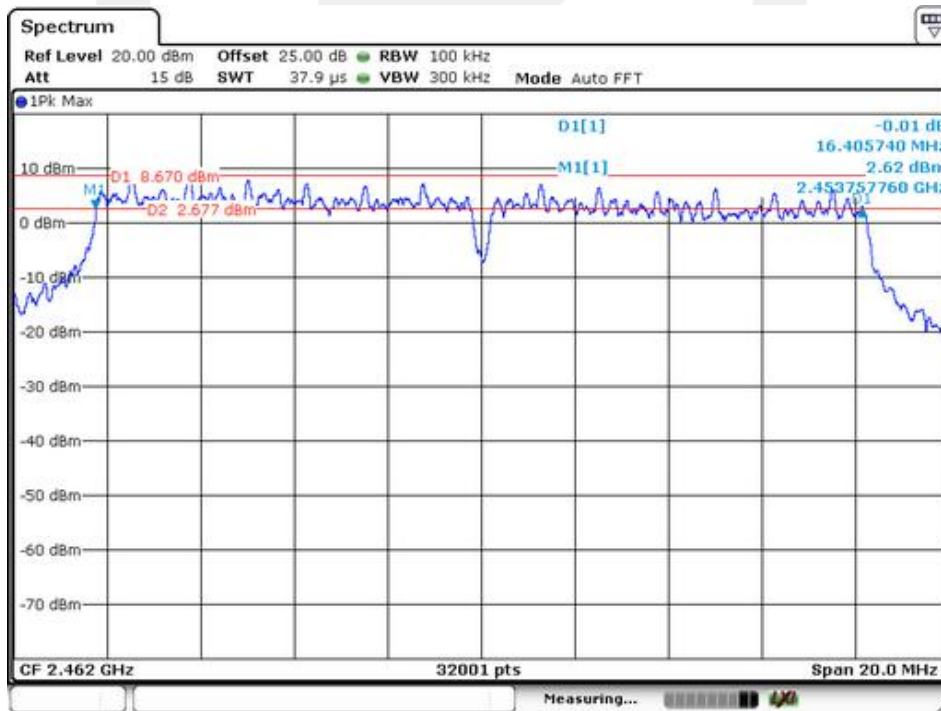
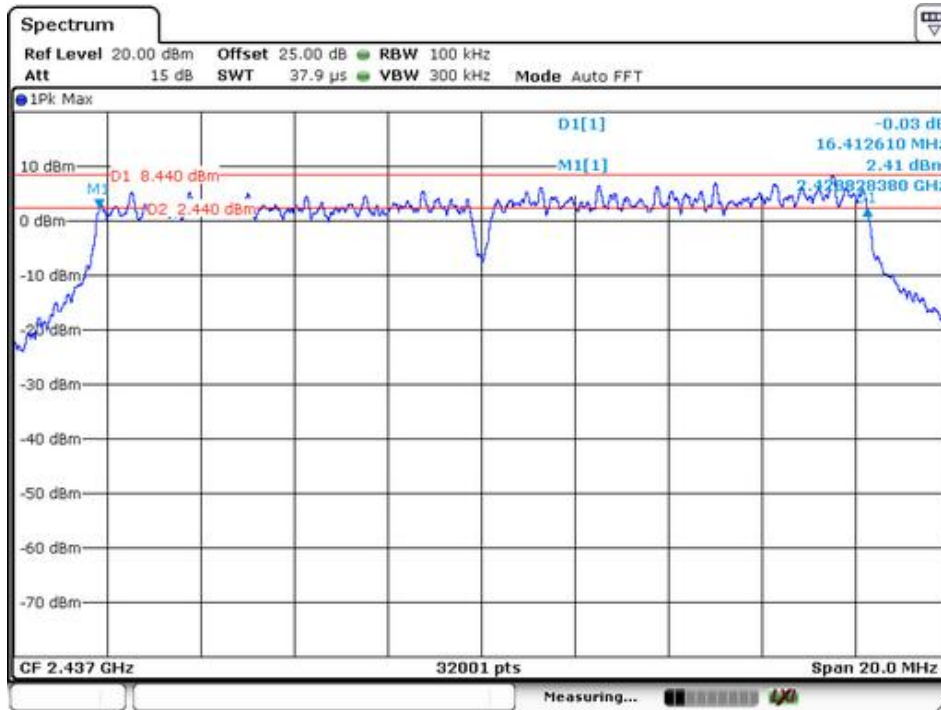

IEEE 802.11n(HT20)			
Channel frequency (MHz)	Measurement level (KHz)	Required Limit (KHz)	Result
2412	17619	>500	Pass
2437	17280	>500	
2462	17050	>500	

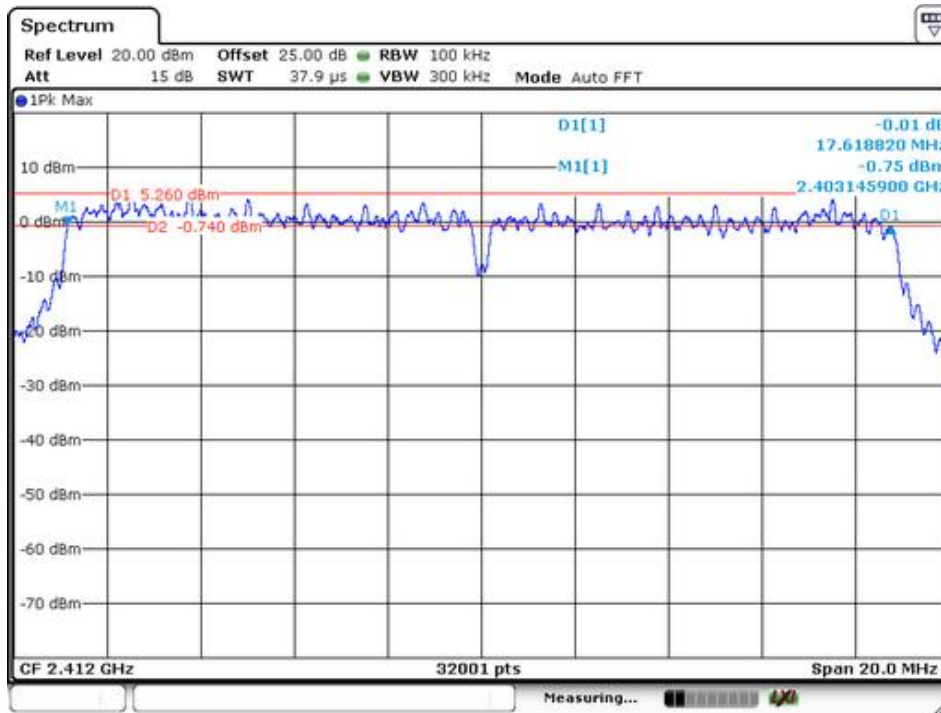



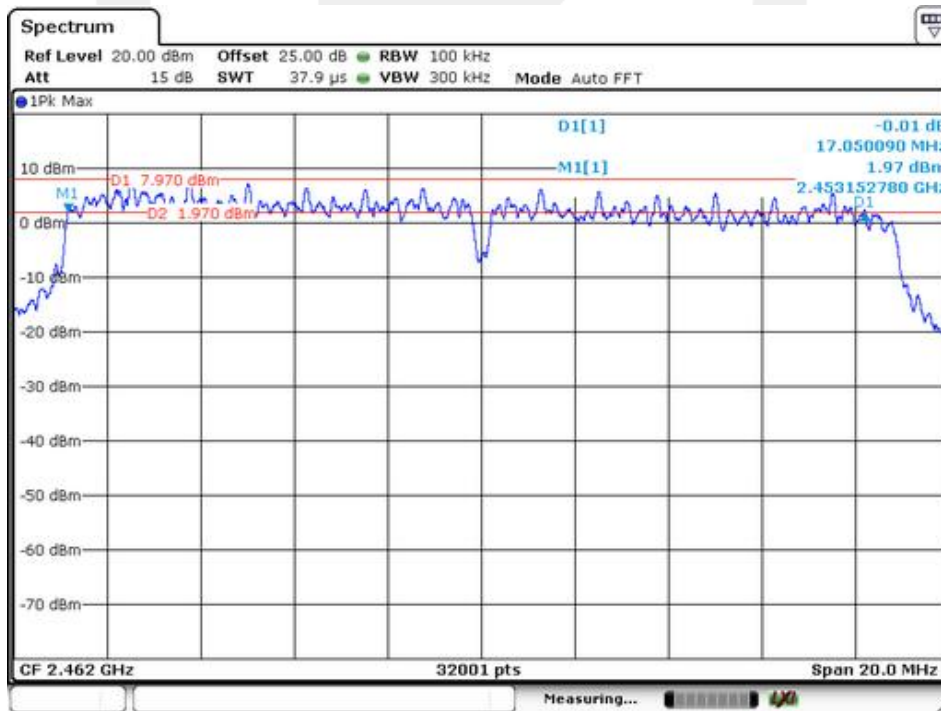
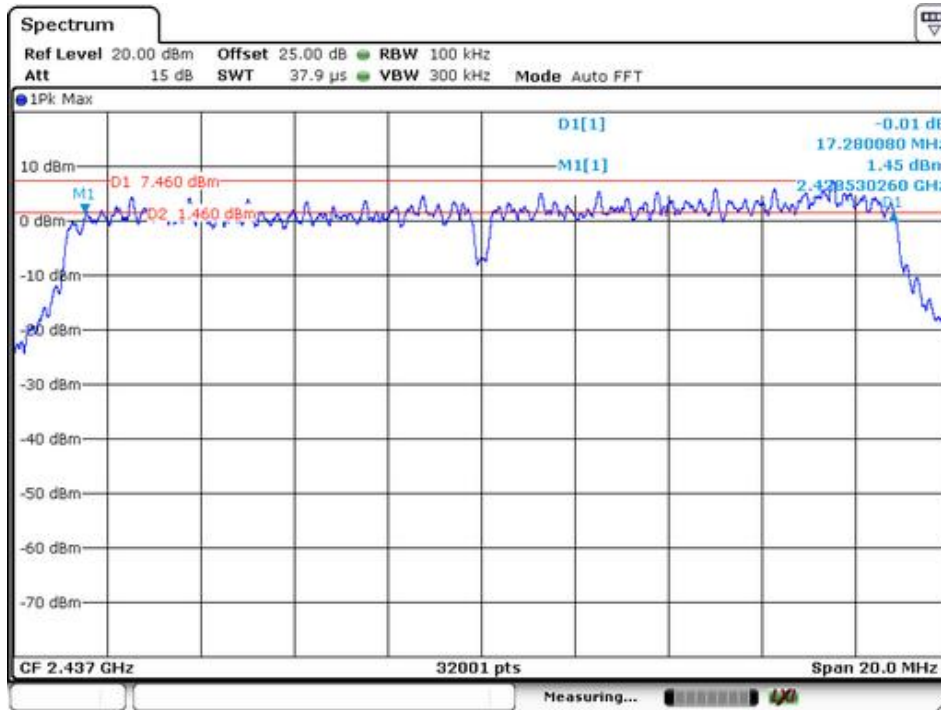

IEEE 802.11n (HT40)			
Channel frequency (MHz)	Measurement level (KHz)	Required Limit (KHz)	Result
2422	36441	>500	Pass
2437	35753	>500	
2452	35399	>500	

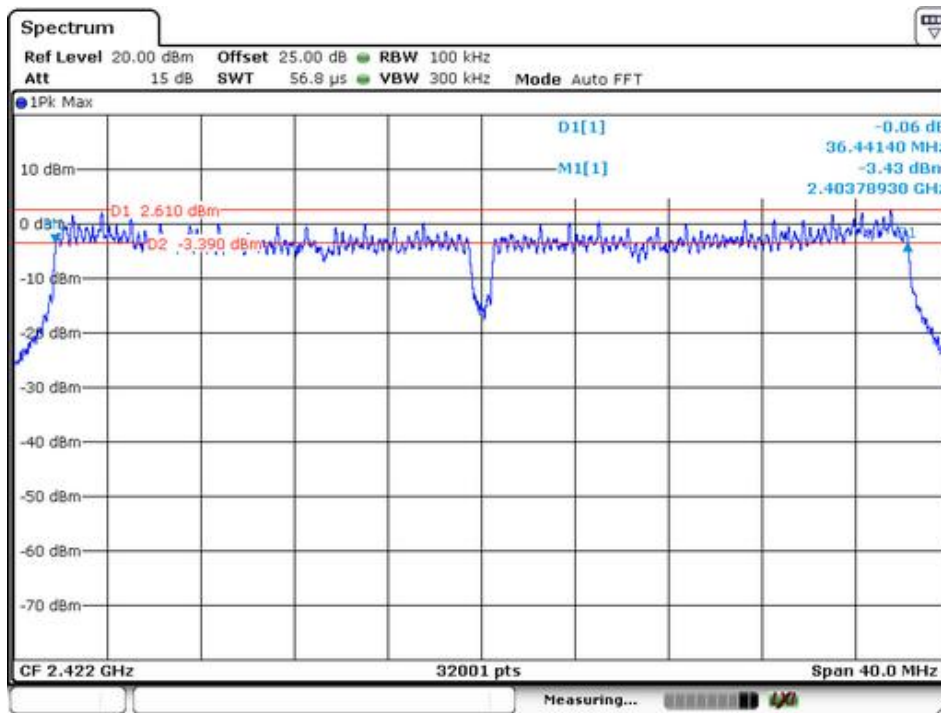

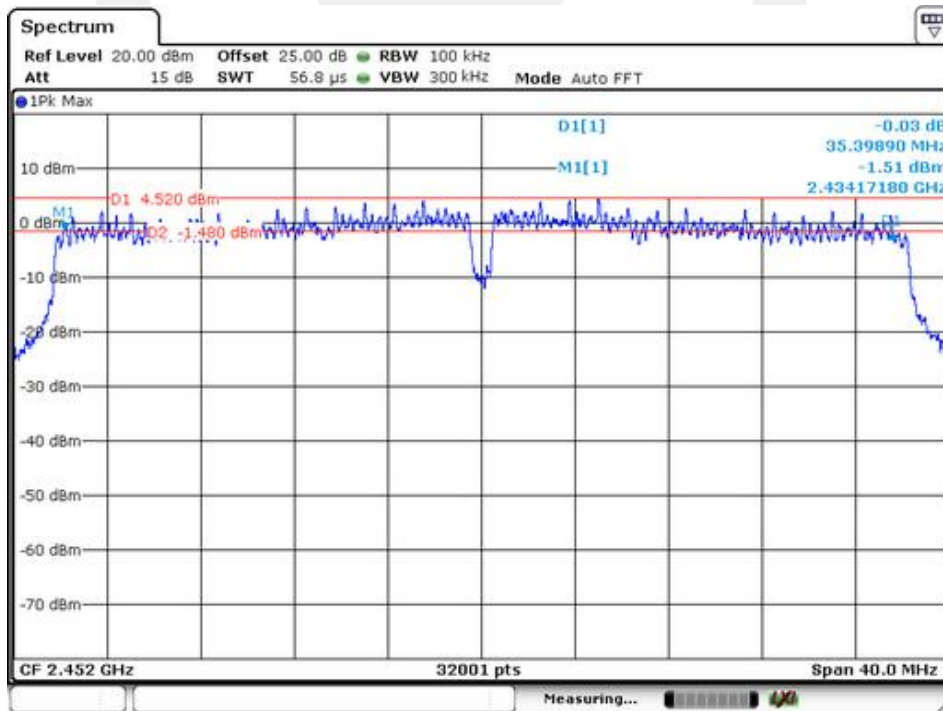
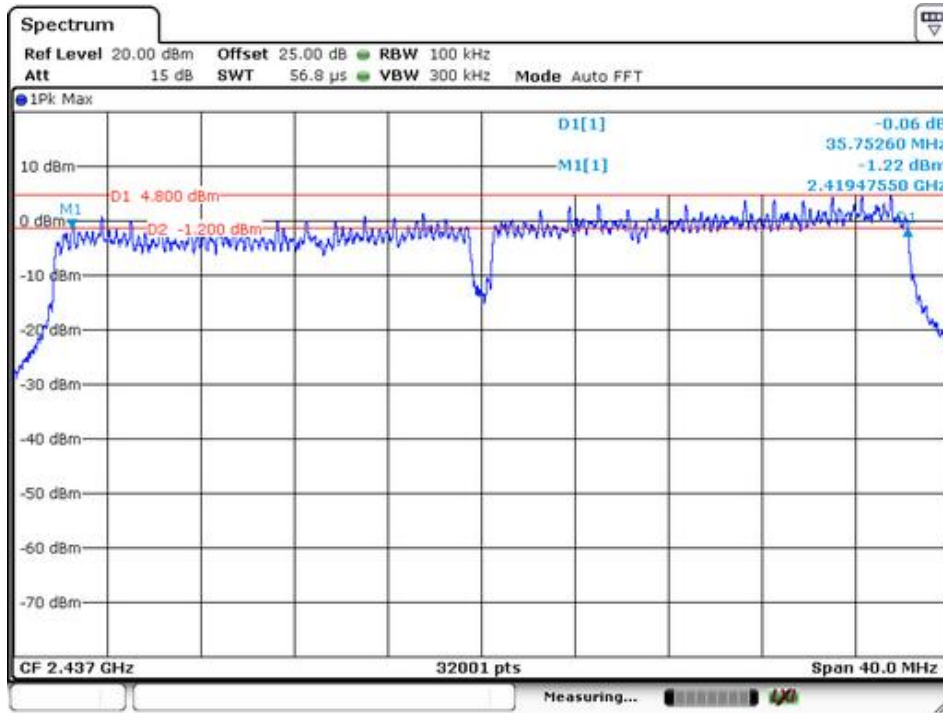

## 11. Maximum Peak Output Power Test

### 11.1 Measurement Procedure

1. The testing follows the Measurement Procedure of FCC KDB No. 558074 DTS D01 Meas. Guidance v04.
2. The RF output of EUT was connected to the power meter by RF cable and attenuator. The path loss was compensated to the results for each measurement.
3. Set to the maximum power setting and enable the EUT transmit continuously.
4. Measure the conducted output power and record the results in the test report.

### 11.2 Test SET-UP (Block Diagram of Configuration)



### 11.3 Measurement Equipment Used

EQUIPMENT TYPE	MODEL NUMBER	SERIAL NUMBER	LAST CAL.	CAL DUE.
Power meter	ML2495A	0824006	05/23/2019	05/22/2020
Power sensor	MA2411B	0738172	05/23/2019	05/22/2020

### 11.4 Peak Power output limit

The maximum peak conducted output power of the intentional radiator for systems using digital modulation in the 2400 - 2483.5 MHz bands shall not exceed: 1 Watt (30dBm).

### 11.5 Measurement Results

Spectrum Detector:	PK	Test Date :	February 17, 2020
Test By:	Loren	Temperature :	28°C
Test Result:	PASS	Humidity :	60%

Test Channel	Peak Output Power (dBm)				Limit(dBm)	Result
	802.11b	802.11g	802.11n(HT20)	802.11n(HT40)		
Lowest	15.34	14.16	10.27	8.36	30	Pass
Middle	15.29	14.04	10.24	8.34		
Highest	15.18	14.09	10.23	8.35		

## 12. Band Edge Test

### 12.1 Measurement Procedure

#### For Conducted Test

1. The testing follows FCC KDB Publication No. 558074 DTS D01 Meas. Guidance v04.
2. The RF output of EUT was connected to the spectrum analyzer by RF cable and attenuator. The path loss was compensated to the results for each measurement.
3. Set to the maximum power setting and enable the EUT transmit continuously.
4. Set RBW = 100 kHz, VBW=300 kHz, Peak Detector. Unwanted Emissions measured in any 100 kHz bandwidth outside of the authorized frequency band shall be attenuated by at least 20 dB relative to the maximum in-band peak PSD level in 100 kHz when maximum peak conducted output power procedure is used. Measure and record the results in the test report.
5. The RF fundamental frequency should be excluded against the limit line in the operating frequency band.

#### For Radiated emission Test

1. The testing follows FCC KDB Publication No. 558074 DTS D01 Meas. Guidance v04.
2. The EUT was arranged to its worst case and then tune the antenna tower (from 1 m to 4 m) and turntable (from 0 degree to 360 degrees) to find the maximum reading. A pre-amp and a high pass filter are used for the test in order to get better signal level.
3. The EUT was placed on a turntable with 0.8 meter above ground.
4. The EUT was set 3 meters from the interference receiving antenna, which was mounted on the top of a variable height antenna tower.
5. Corrected Reading: Antenna Factor + Cable Loss + Read Level - Preamp Factor = Level.
6. For measurement below 1GHz, If the emission level of the EUT measured by the peak detector is 3 dB lower than the applicable limit, the peak emission level will be reported. Otherwise, the emission measurement will be repeated using the quasi-peak detector and reported.
7. Repeat above procedures until all frequency measured were complete.

When spectrum scanned above 1GHz setting resolution bandwidth 1MHz, video bandwidth 3MHz.

EMI Test Receiver	Setting
Attenuation	Auto
RBW	1MHz
VBW	3MHz
Detector	Peak
Trace	Max hold

When spectrum scanned above 1GHz setting resolution bandwidth 1MHz, video bandwidth 10Hz.

EMI Test Receiver	Setting
Attenuation	Auto
RBW	1MHz
VBW	10Hz
Detector	Peak
Trace	Max hold

### 12.2 Test SET-UP (Block Diagram of Configuration)

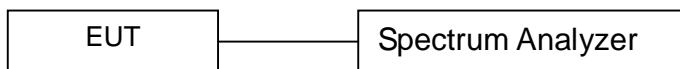

### 12.3 Measurement Equipment Used

EQUIPMENT TYPE	MFR	MODEL NUMBER	SERIAL NUMBER	LAST CAL.	CAL DUE.
Spectrum Analyzer	Agilent	FSV30	1321.3008K	05/23/2019	05/22/2020

### 12.4 Measurement Results

#### 1. Conducted Test

Test Mode: IEEE 802.11b

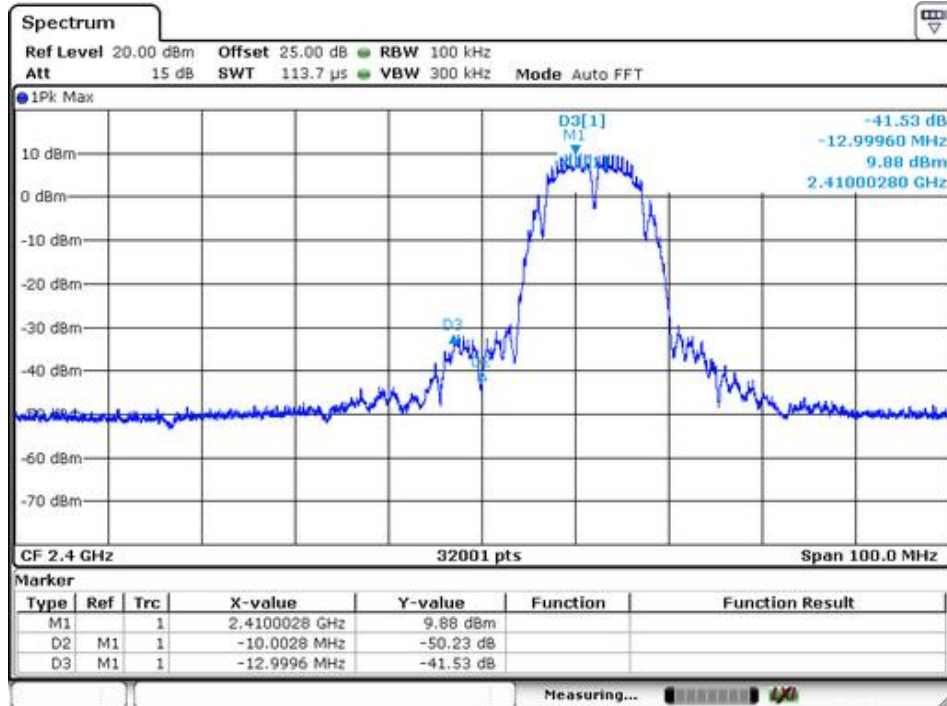

## Test Mode: IEEE 802.11g

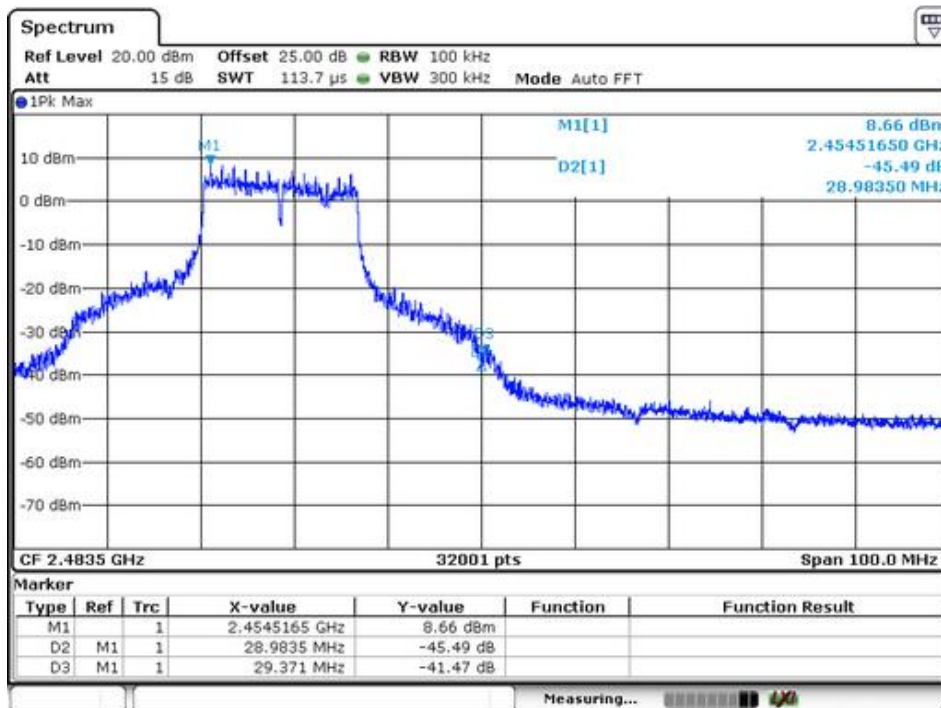
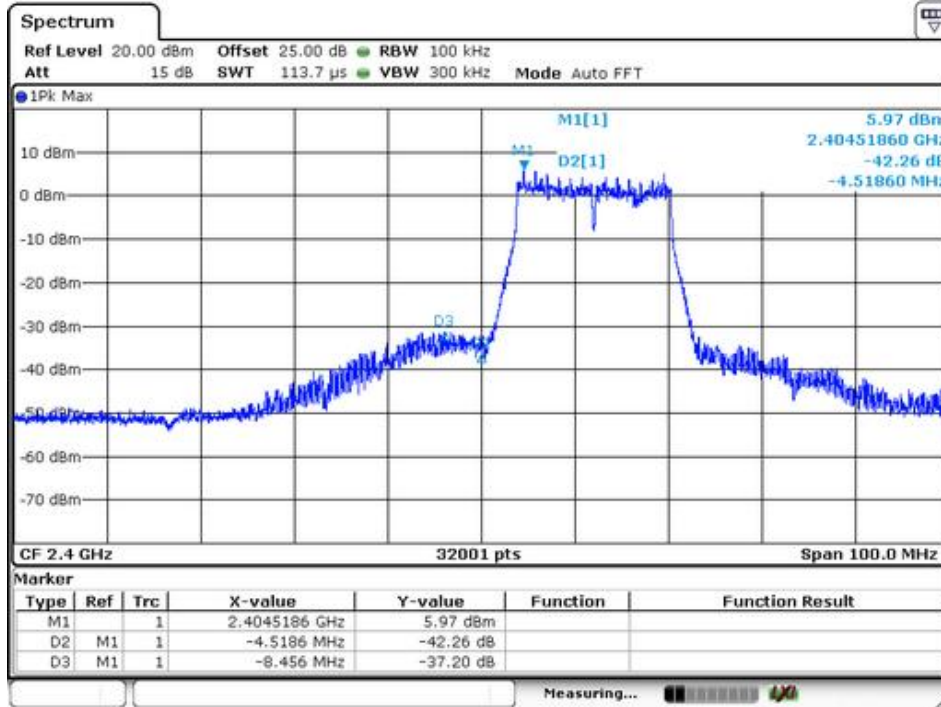



## Test Mode: IEEE 802.11n(HT20)

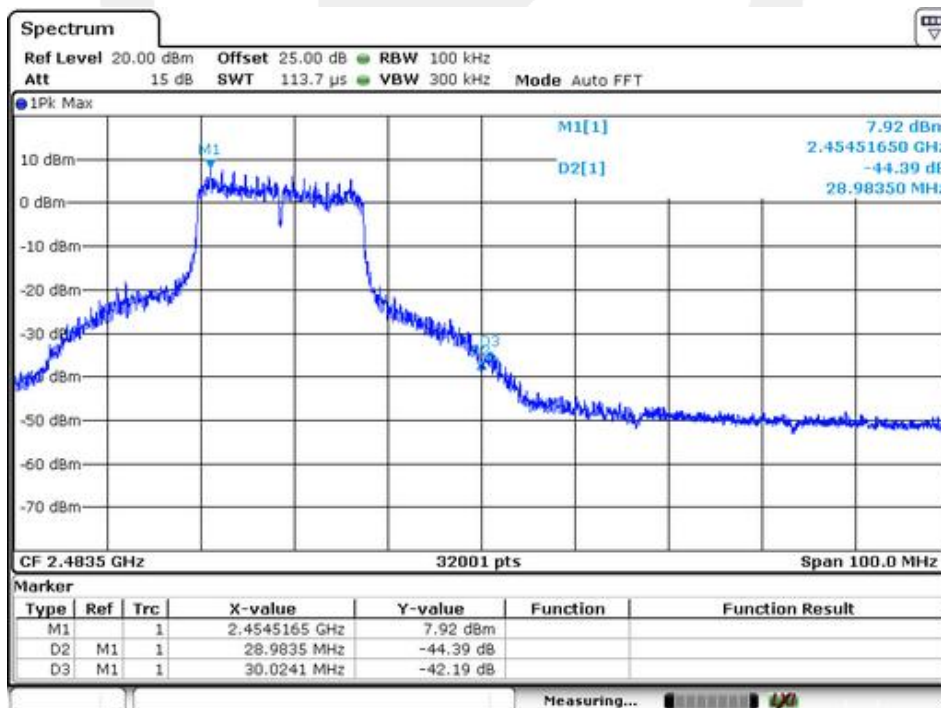
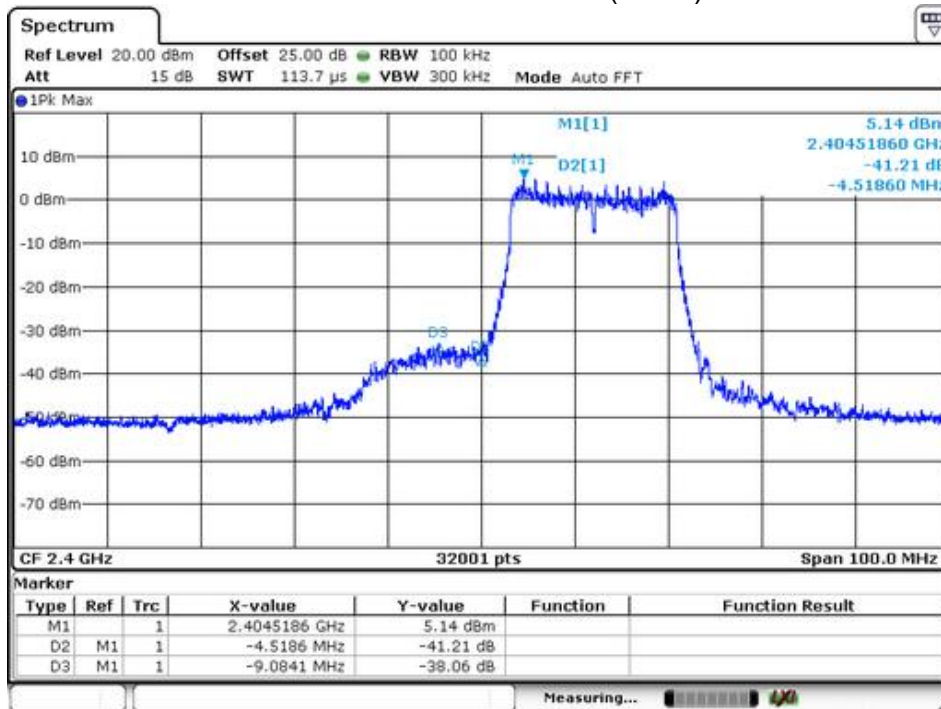

## Test Mode: IEEE 802.11n(HT40)

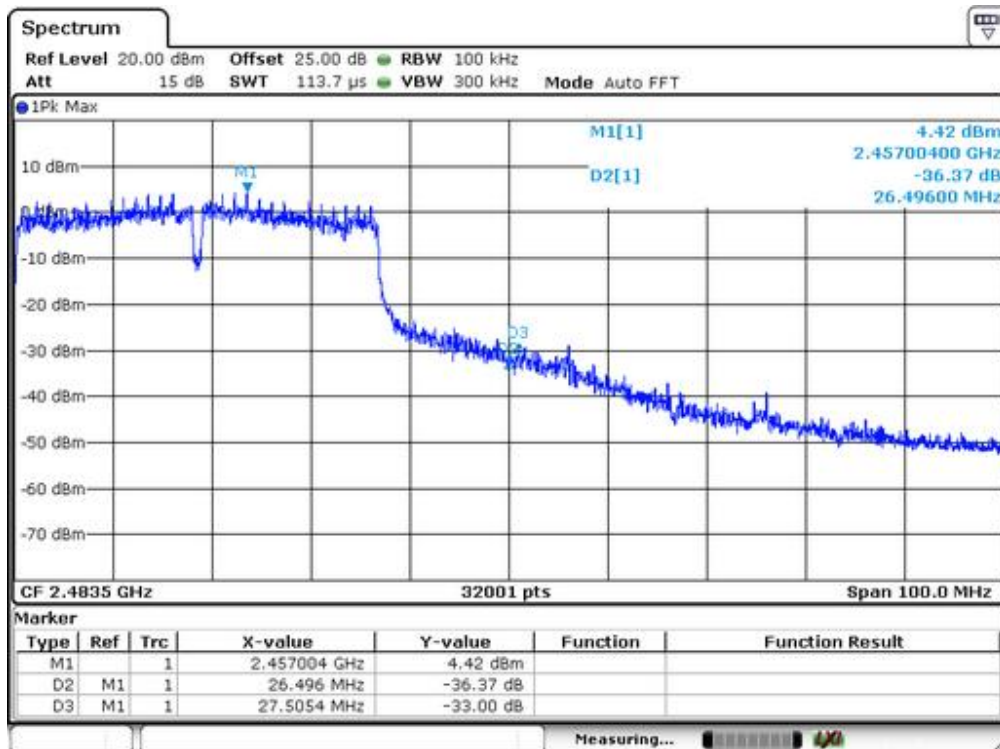
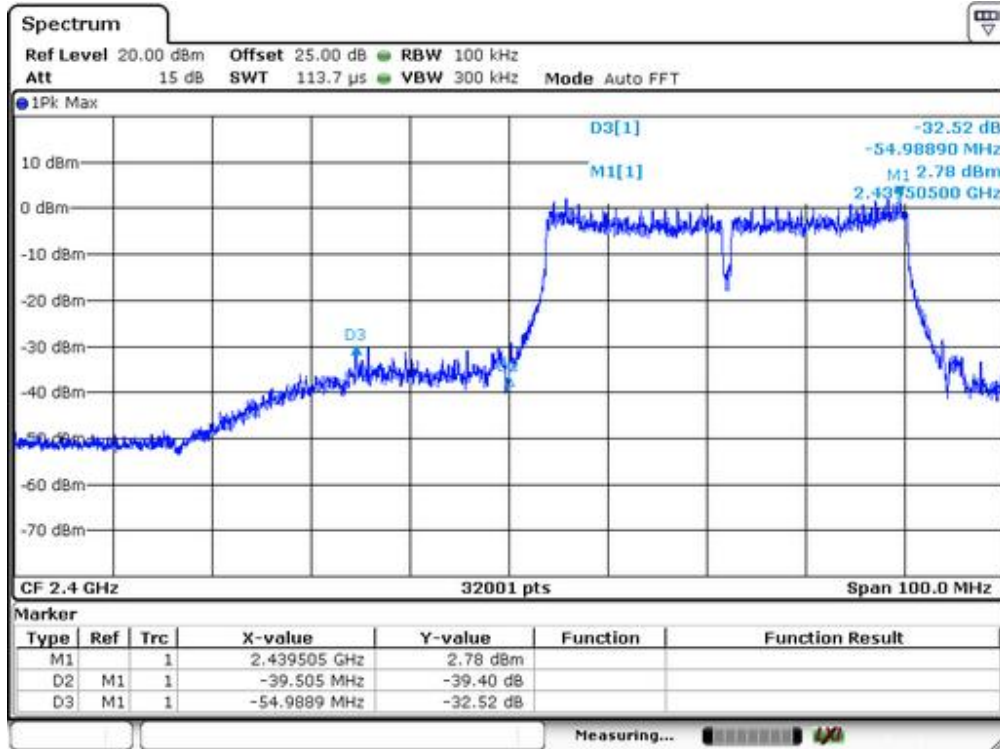

## 2. Radiated emission Test

Spectrum Detector: PK/AV      Test Date : February 17, 2020  
 Test By: Loren      Temperature : 28 °C  
 Humidity : 65 %

IEEE 802.11b										
Freq. (MHz)	Ant. Pol. H/V	Reading Level(dBuV/m)		Correct Factor dB	Emission Level(dBuV/m)		Limit 3m		Margin(dB)	
		PK	AV		PK	AV	PK	AV	PK	AV
<2400	H	87.53	68.45	-26.3	61.23	42.15	74	54	-12.77	-11.85
<2400	V	86.75	66.29	-26.1	60.65	40.19	74	54	-13.35	-13.81
>2483.5	H	88.48	67.67	-26.3	62.18	41.37	74	54	-11.82	-12.63
>2483.5	V	85.78	65.34	-26.1	59.68	39.24	74	54	-14.32	-14.76

IEEE 802.11g										
Freq. (MHz)	Ant. Pol. H/V	Reading Level(dBuV/m)		Correct Factor dB	Emission Level(dBuV/m)		Limit 3m		Margin(dB)	
		PK	AV		PK	AV	PK	AV	PK	AV
<2400	H	88.64	68.85	-26.3	62.34	42.55	74	54	-11.66	-11.45
<2400	V	87.69	68.23	-26.1	61.59	42.13	74	54	-12.41	-11.87
>2483.5	H	86.87	67.98	-26.3	60.57	41.68	74	54	-13.43	-12.32
>2483.5	V	86.44	67.26	-26.1	60.34	41.16	74	54	-13.66	-12.84

IEEE 802.11n(HT20)										
Freq. (MHz)	Ant. Pol. H/V	Reading Level(dBuV/m)		Correct Factor dB	Emission Level(dBuV/m)		Limit 3m		Margin(dB)	
		PK	AV		PK	AV	PK	AV	PK	AV
<2400	H	88.63	69.97	-26.3	62.33	43.67	74	54	-11.67	-10.33
<2400	V	87.39	68.25	-26.1	61.29	42.15	74	54	-12.71	-11.85
>2483.5	H	89.87	68.57	-26.3	63.57	42.27	74	54	-10.43	-11.73
>2483.5	V	87.68	66.25	-26.1	61.58	40.15	74	54	-12.42	-13.85

IEEE 802.11n(HT40)										
Freq. (MHz)	Ant. Pol. H/V	Reading Level(dBuV/m)		Correct Factor dB	Emission Level(dBuV/m)		Limit 3m		Margin(dB)	
		PK	AV		PK	AV	PK	AV	PK	AV
<2400	H	89.64	68.87	-26.3	63.34	42.57	74	54	-10.66	-11.43
<2400	V	86.25	66.64	-26.1	60.15	40.54	74	54	-13.85	-13.46
>2483.5	H	88.88	68.61	-26.3	62.58	42.31	74	54	-11.42	-11.69
>2483.5	V	86.47	67.36	-26.1	60.37	41.26	74	54	-13.63	-12.74

## 13. Maximum Power Spectral Density

### 13.1 Test Equipment

EQUIPMENT TYPE	MFR	MODEL NUMBER	SERIAL NUMBER	LAST CAL.	CAL DUE.
Spectrum Analyzer	Agilent	FSV30	1321.3008K	05/23/2019	05/22/2020

### 13.2 Measuring Instruments and Setting

The following table is the setting of spectrum analyzer.

Spectrum analyzer	Setting
Attenuation	Auto
Span Frequency	Set the span to 1.5 times the DTS bandwidth.
RBW	3KHz
VBW	10KHz
Detector	Peak
Trace	Max hold
Sweep Time	Automatic

### 13.3 Test Procedures

- The transmitter output (antenna port) was connected to the spectrum analyzer.
- Set analyzer center frequency to DTS channel center frequency.
- Set the analyzer span to a minimum of 1.5 times the DTS bandwidth.
- Set the RBW=3KHz. Set the VBW=10KHz
- Detector = peak.
- Sweep time = auto couple.
- Trace mode = max hold.
- Allow trace to fully stabilize.
- Use the peak marker function to determine the maximum amplitude level.

### 13.4 Block Diagram of Test Setup

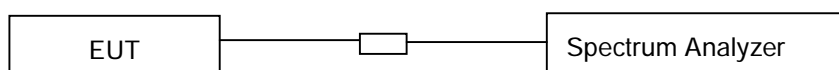

### 13.5 Limit

The transmitted power density averaged over any 1 second interval shall not be greater +8dBm in any 3 kHz bandwidth.

### 13.6 Test Result

Spectrum Detector: PK                      Test Date : February 17, 2020  
 Test By: Loren                              Temperature : 28°C  
 Humidity : 60%

IEEE 802.11b			
Channel frequency (MHz)	Power Density (dBm/3kHz)	Power Density Limit (dBm/3kHz)	Result
2412	-6.10	8	Pass
2437	-4.55		
2462	-4.83		

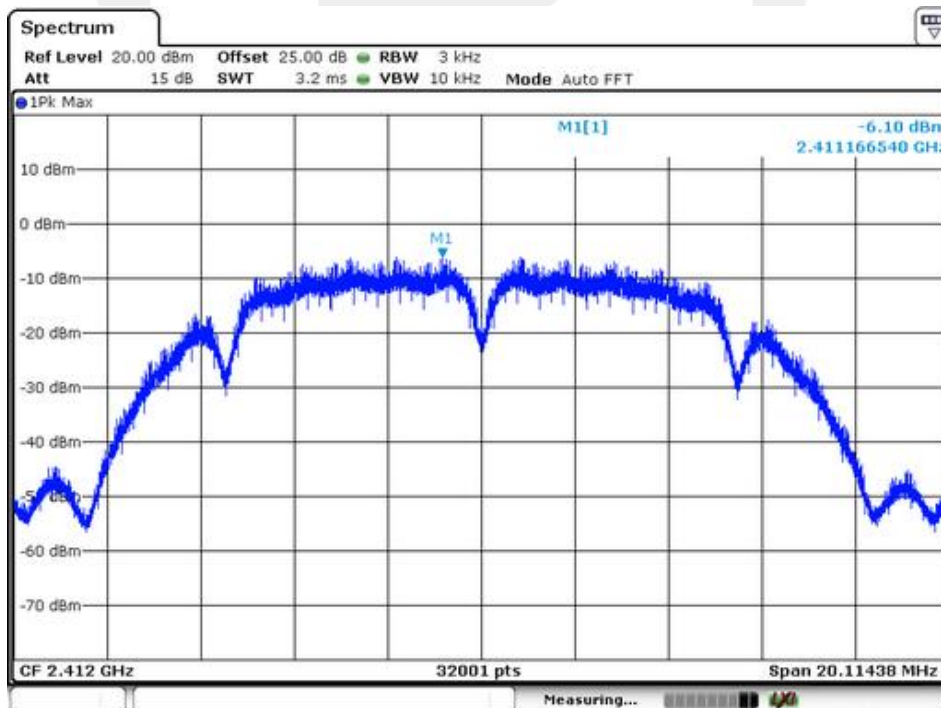

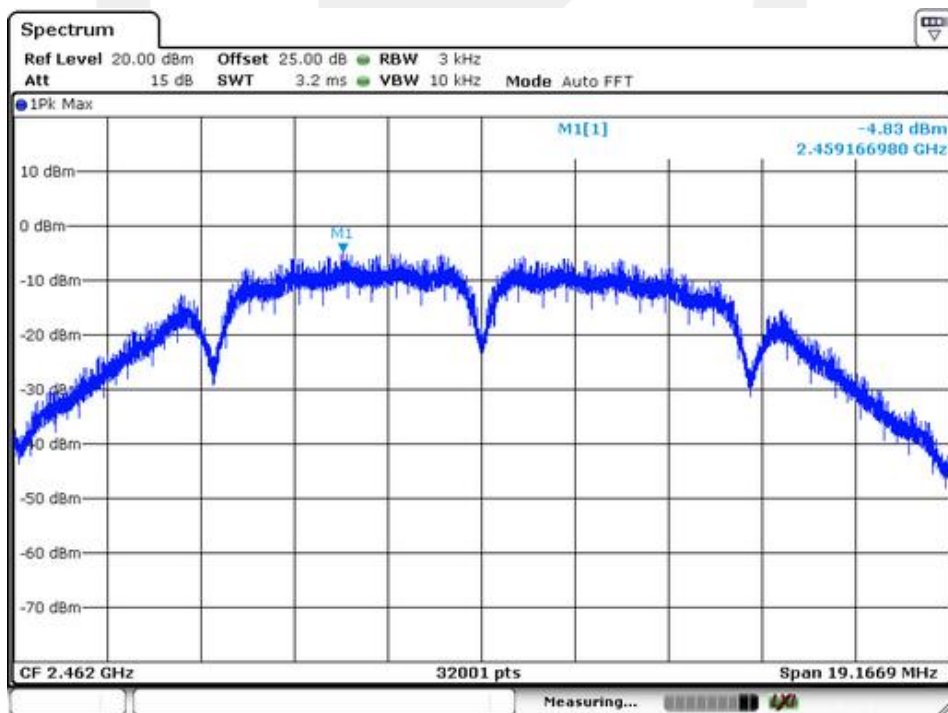
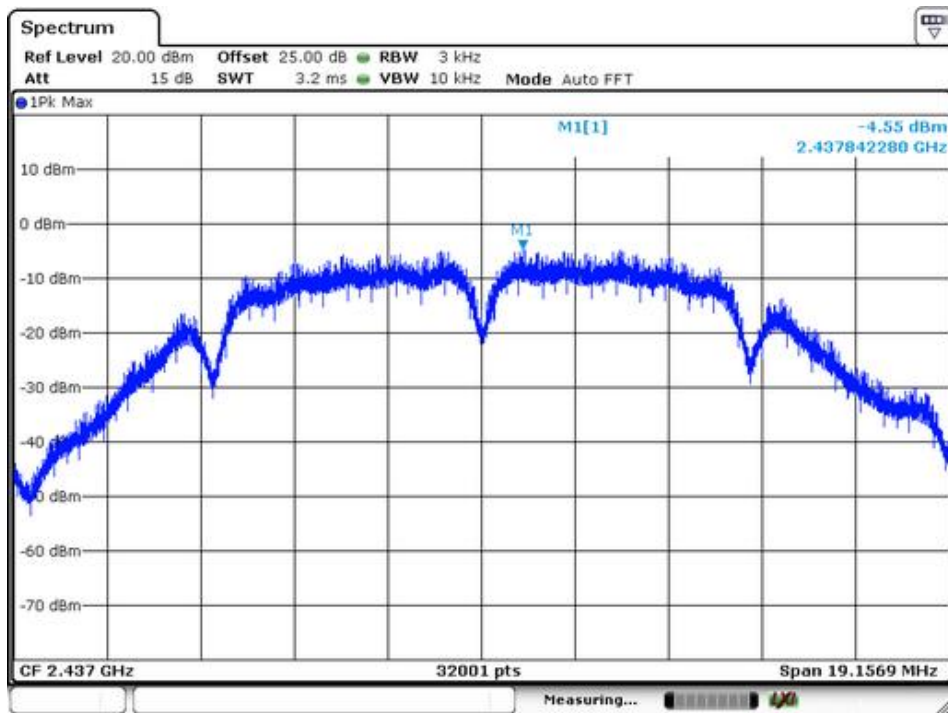

IEEE 802.11g			
Channel frequency (MHz)	Power Density (dBm/3kHz)	Power Density Limit (dBm/3kHz)	Result
2412	-9.83	8	Pass
2437	-7.19		
2462	-7.17		

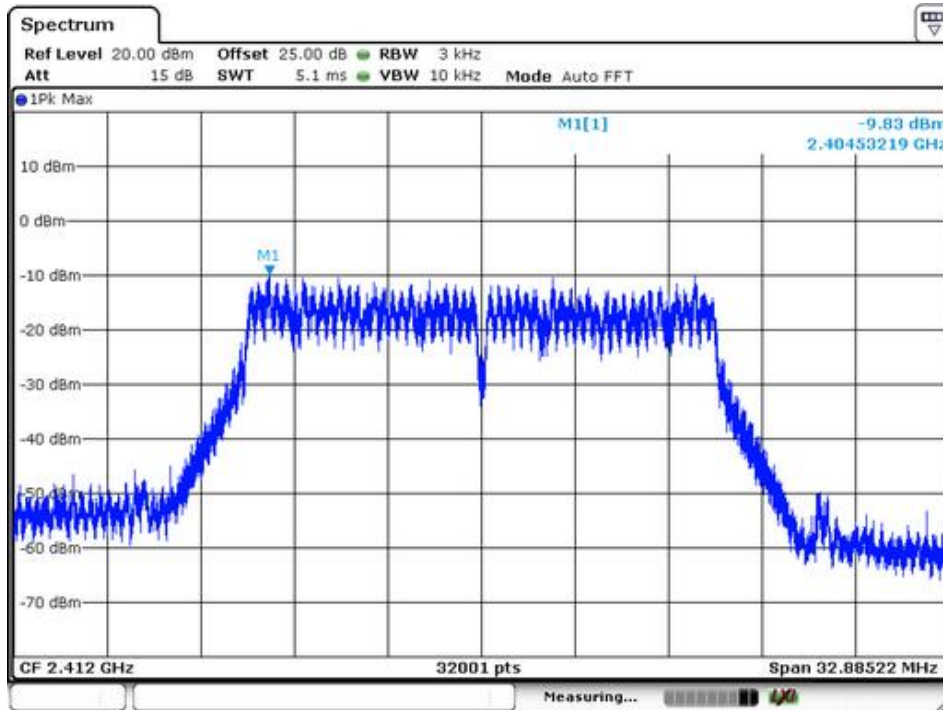

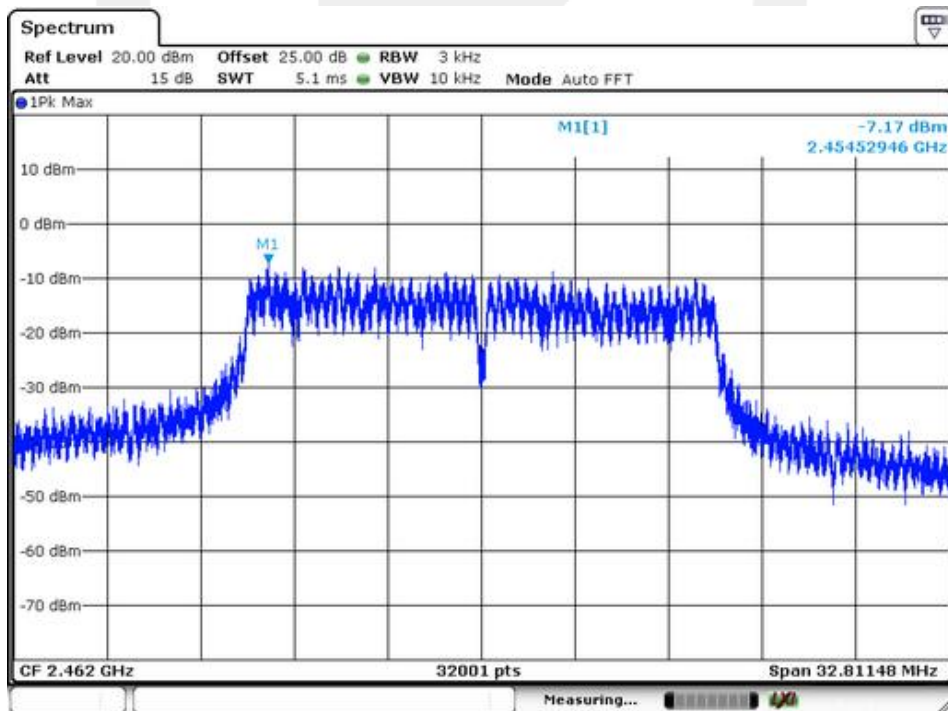
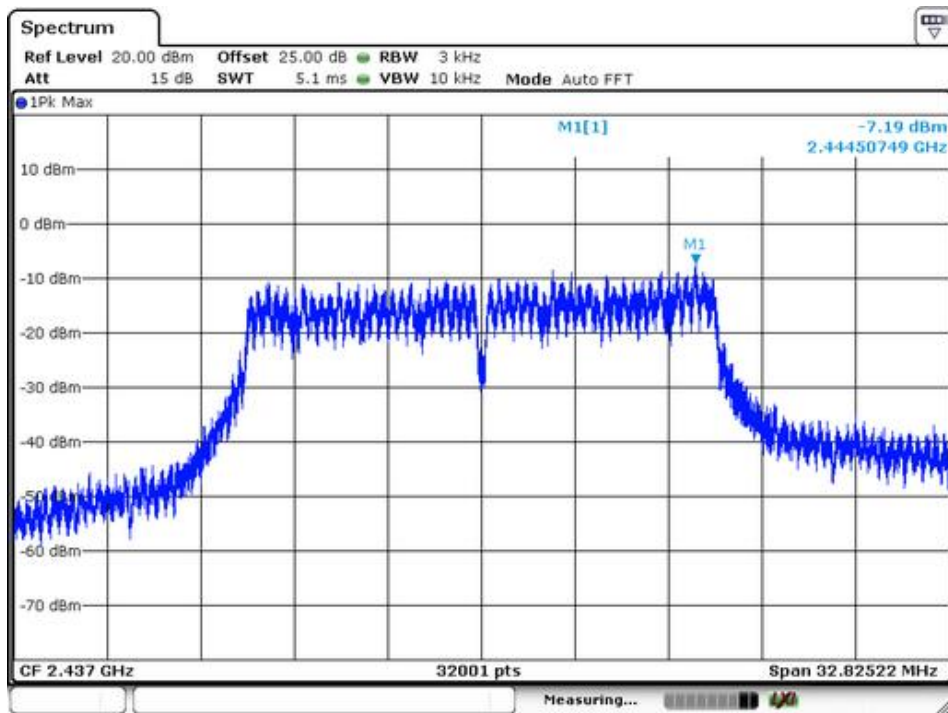



IEEE 802.11n(HT20)			
Channel frequency (MHz)	Measurement level (dBm)	Limit(dBm)	Result
2412	-11.98	8	Pass
2437	-9.75		
2462	-9.10		

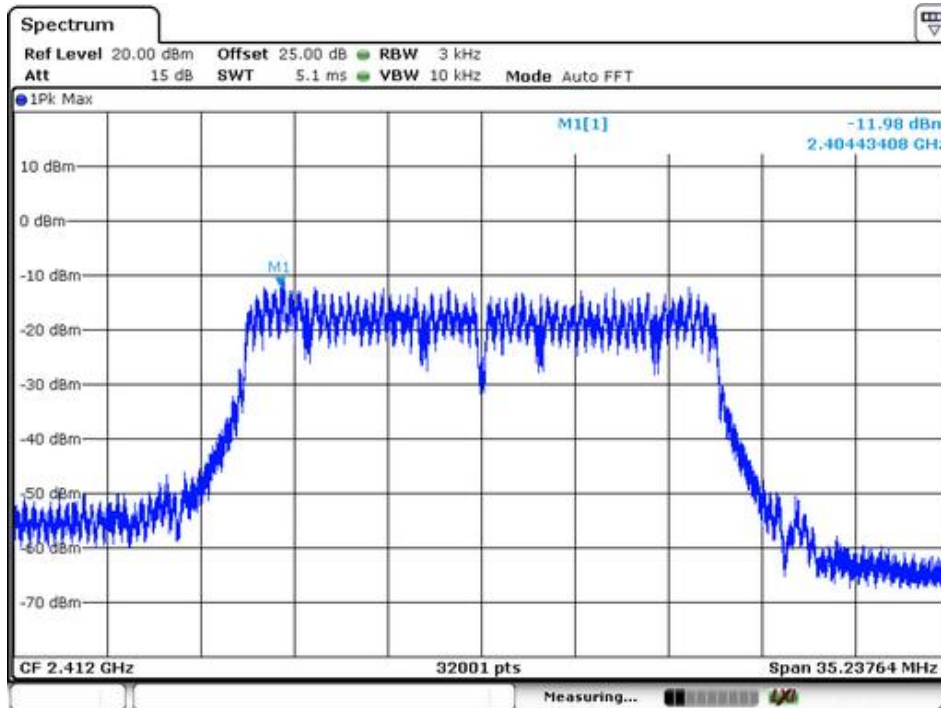

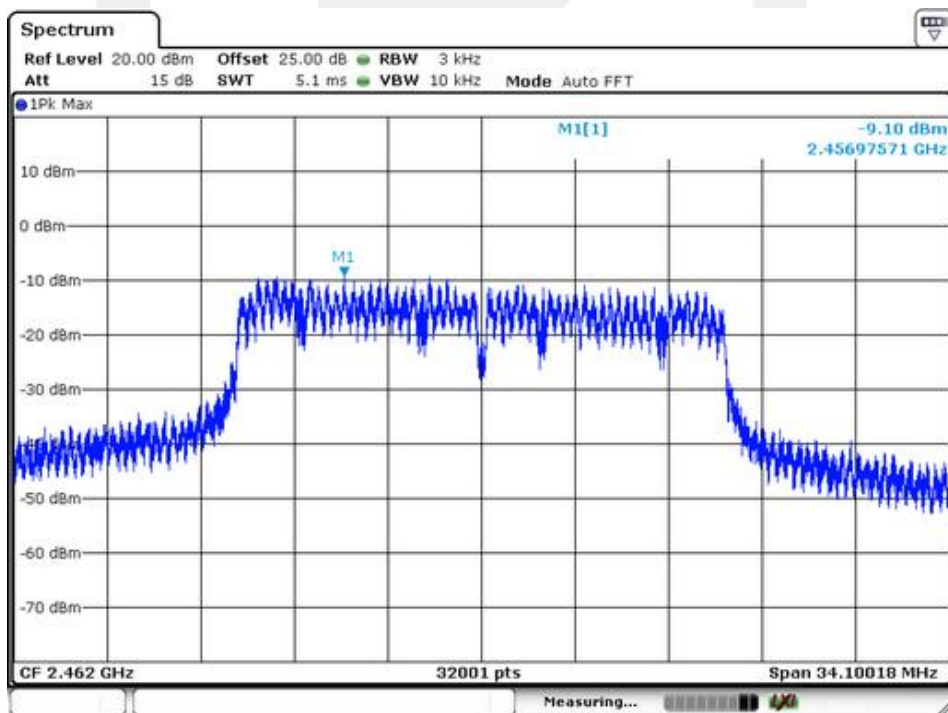
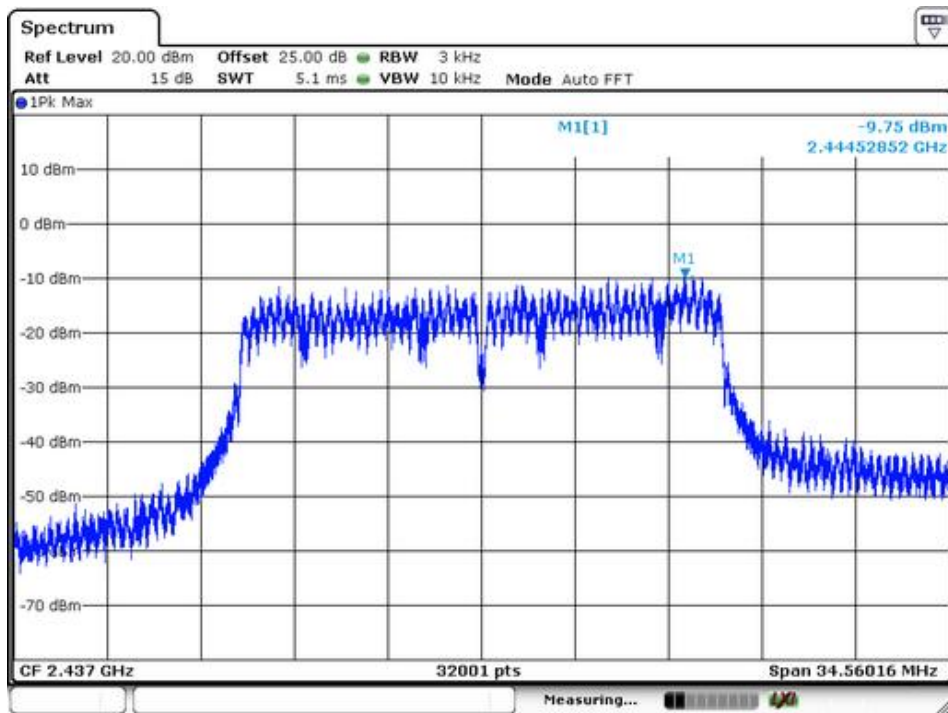

IEEE 802.11n(HT40)			
Channel frequency (MHz)	Measurement level (dBm)	Limit(dBm)	Result
2422	-16.52	8	Pass
2437	-12.97		
2452	-12.34		

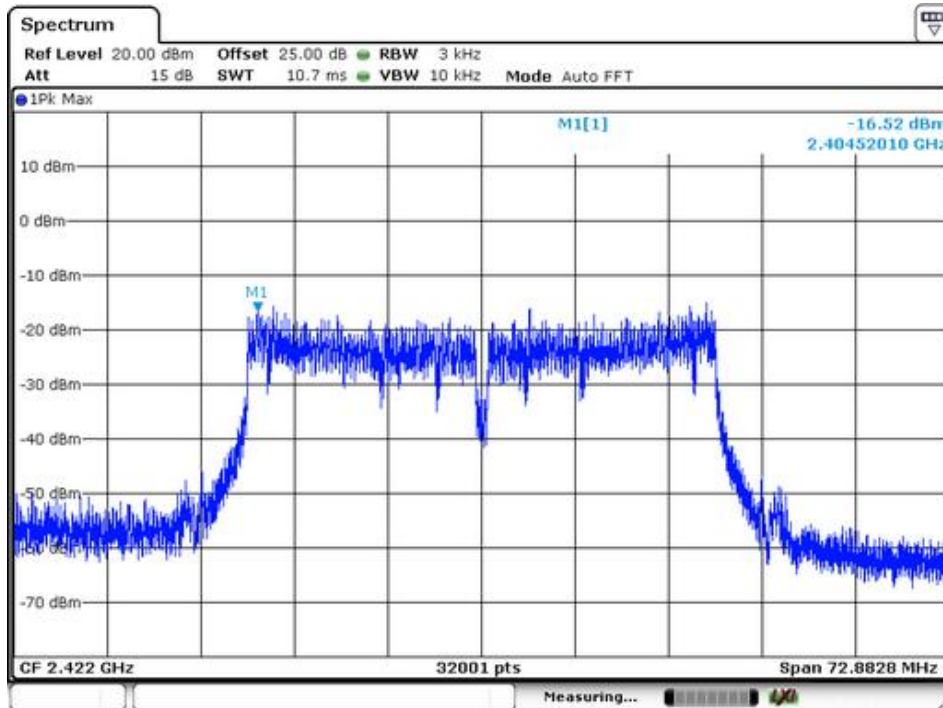

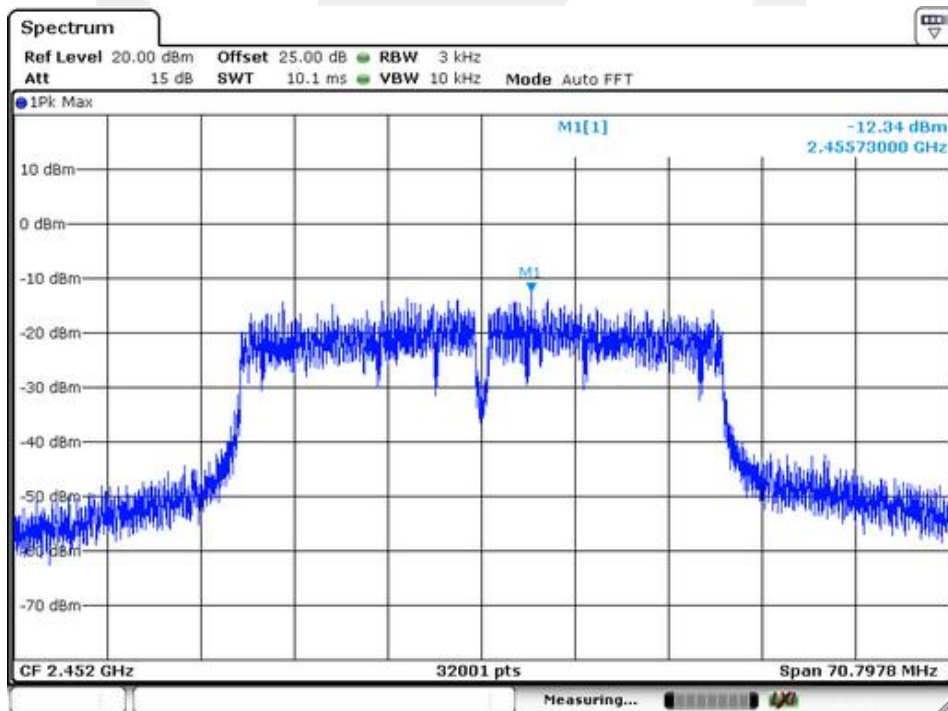
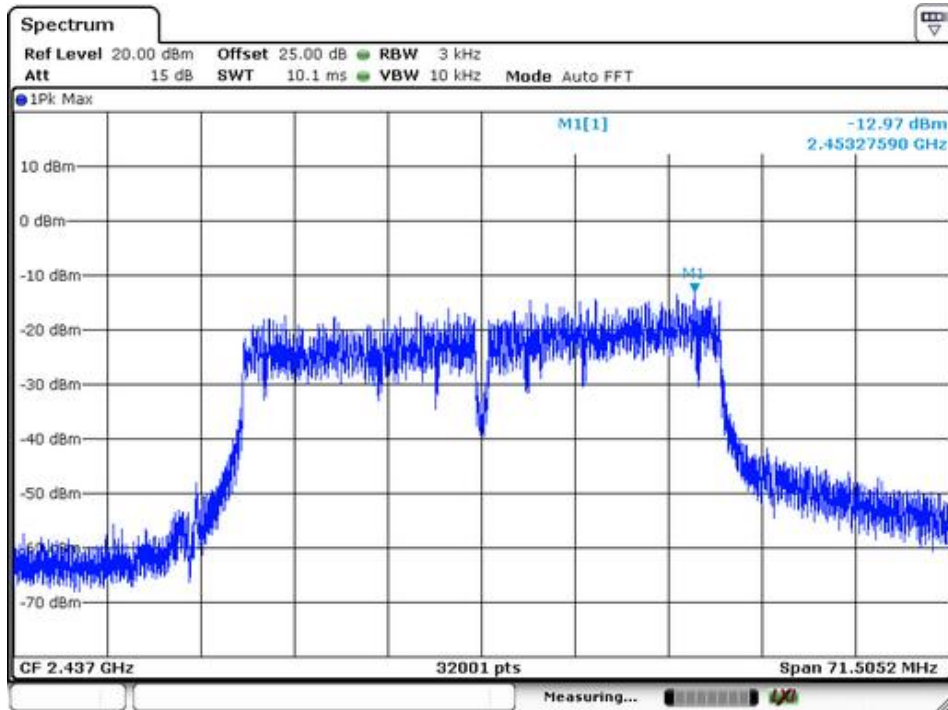

## 14. Antenna Port Emission

### 14.1 Test Equipment

EQUIPMENT TYPE	MFR	MODEL NUMBER	SERIAL NUMBER	LAST CAL.	CAL DUE.
Spectrum Analyzer	Agilent	FSV30	1321.3008K	05/23/2019	05/22/2020

### 14.2 Measuring Instruments and Setting

The following table is the setting of spectrum analyzer.

Spectrum analyzer	Setting
Attenuation	Auto
RBW	100kHz
VBW	300kHz
Detector	Peak
Trace	Max hold

### 14.3 Test Procedures

The conducted spurious emissions were measured conducted using a spectrum analyzer at low, Middle, and high channels, the limit was determined by attenuation 20dB of the RF peak power output.

### 14.4 Block Diagram of Test setup

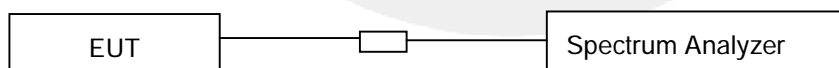

### 14.5 Test Result

**PASS.**

Please refer to the following pages.

Test Mode: IEEE 802.11b

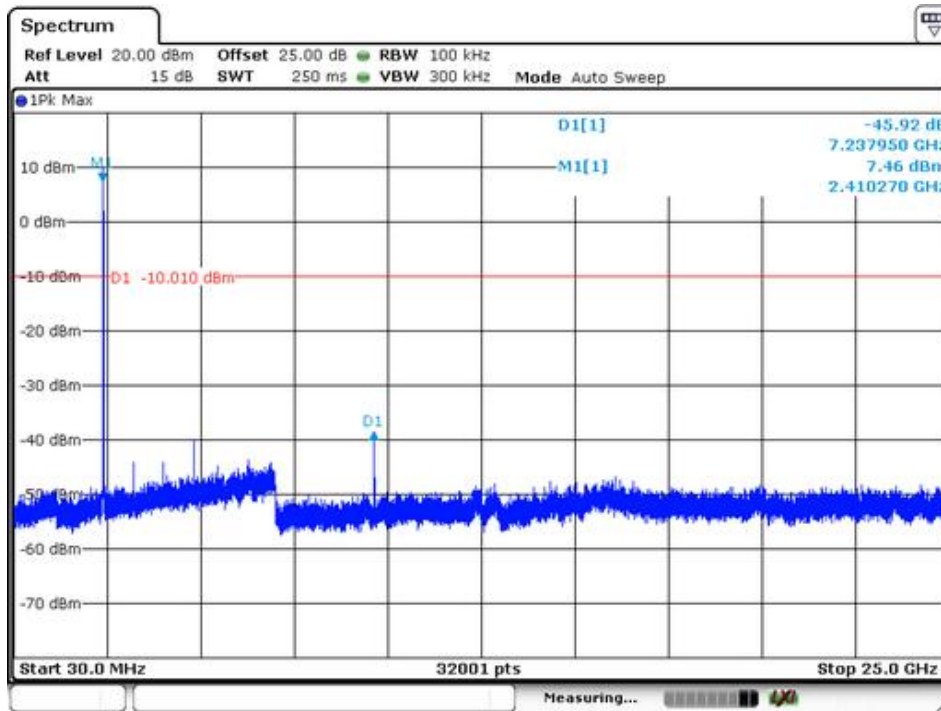

Lowest Channel

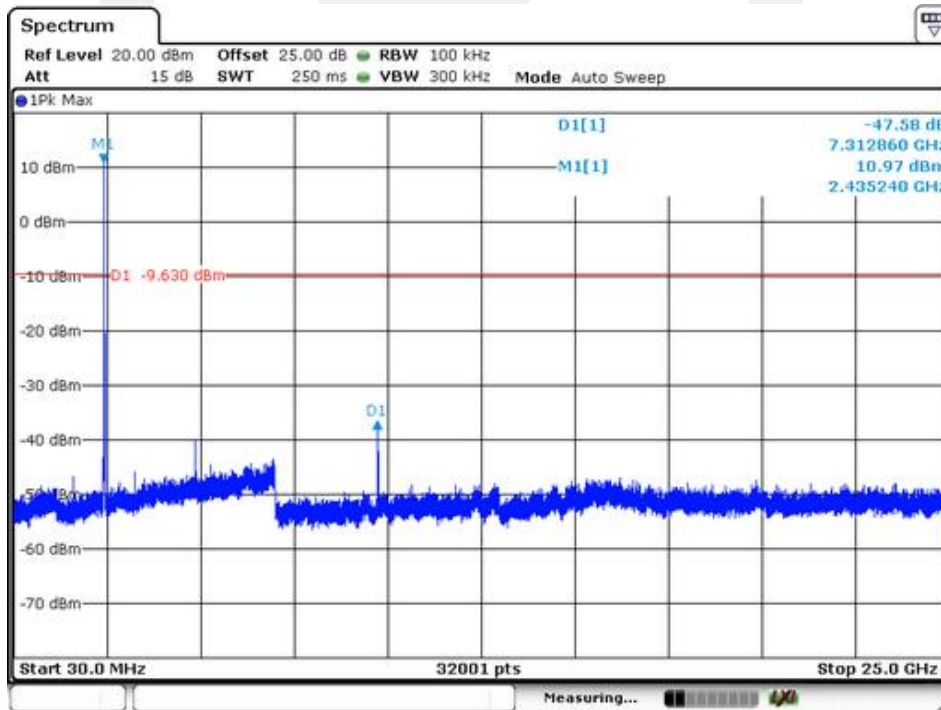

Middel Channel

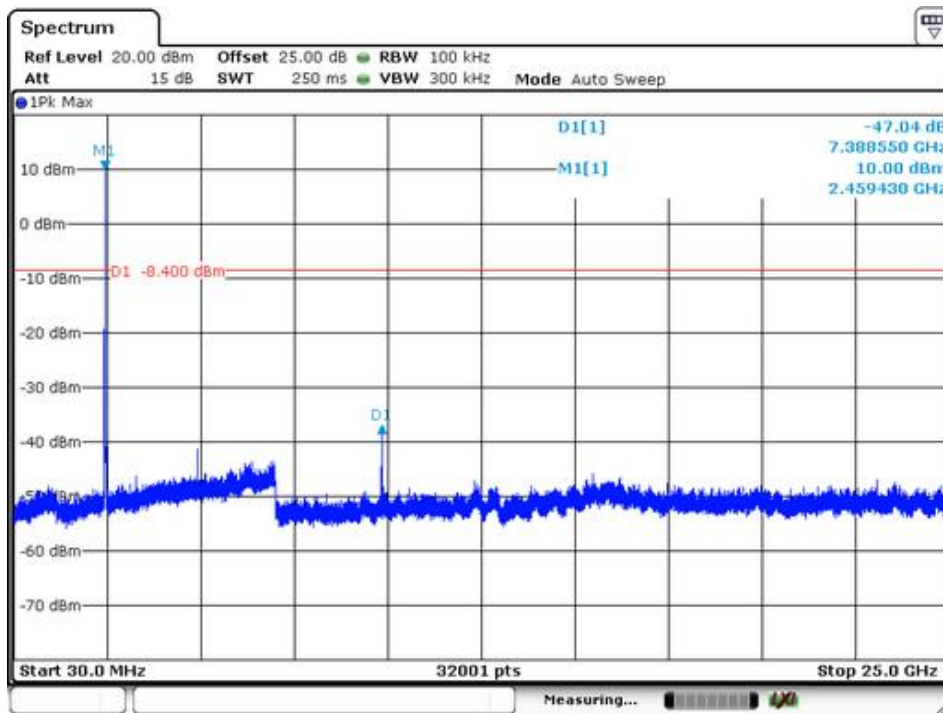

Highest Channel

Test Mode: IEEE 802.11g

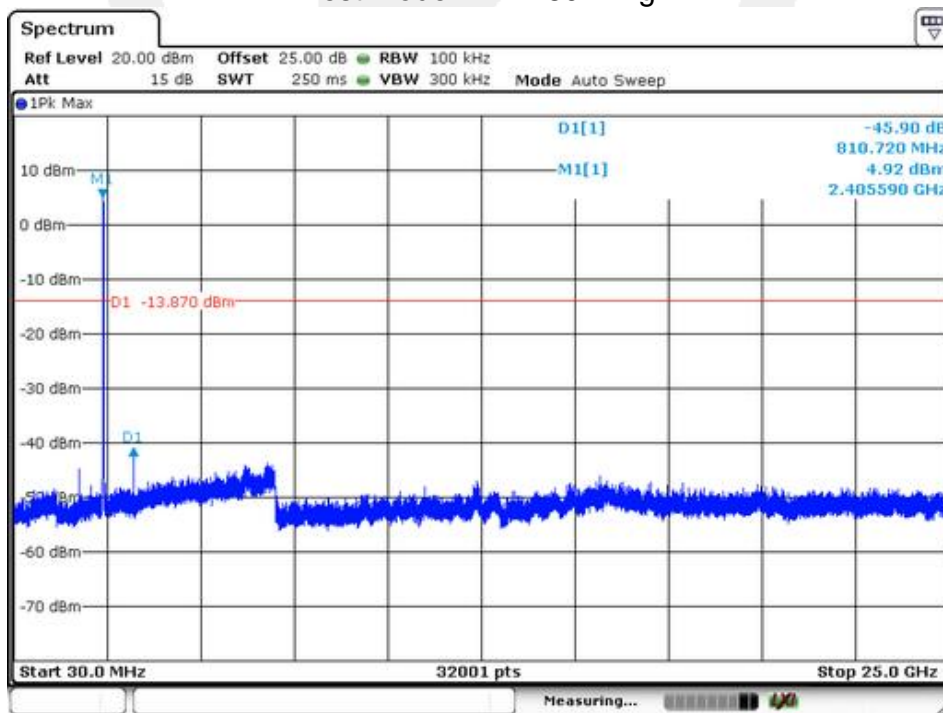

Lowest Channel

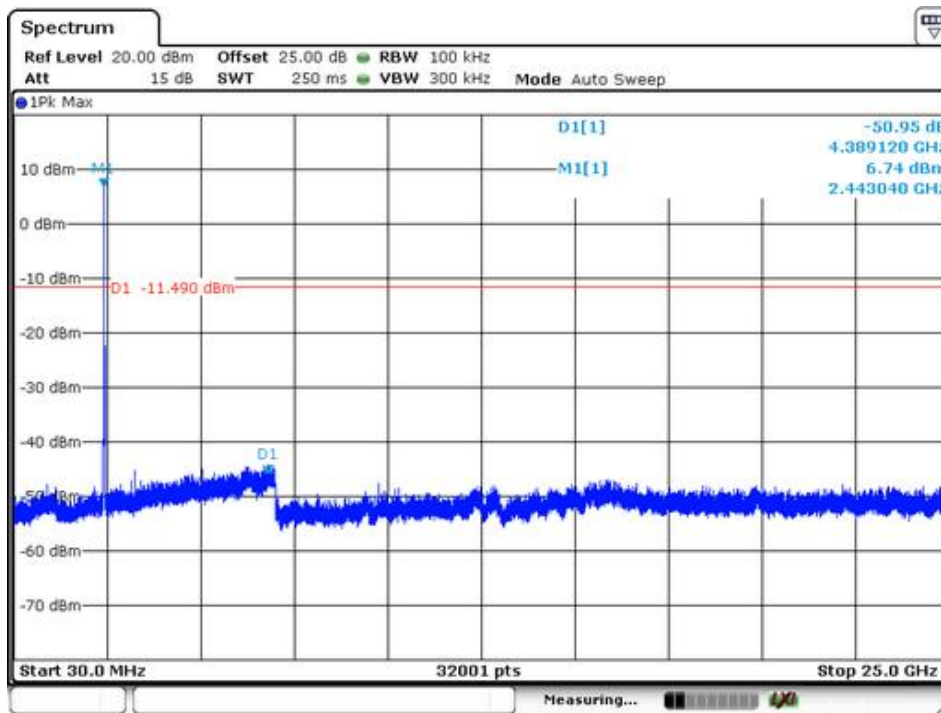

Middle Channel

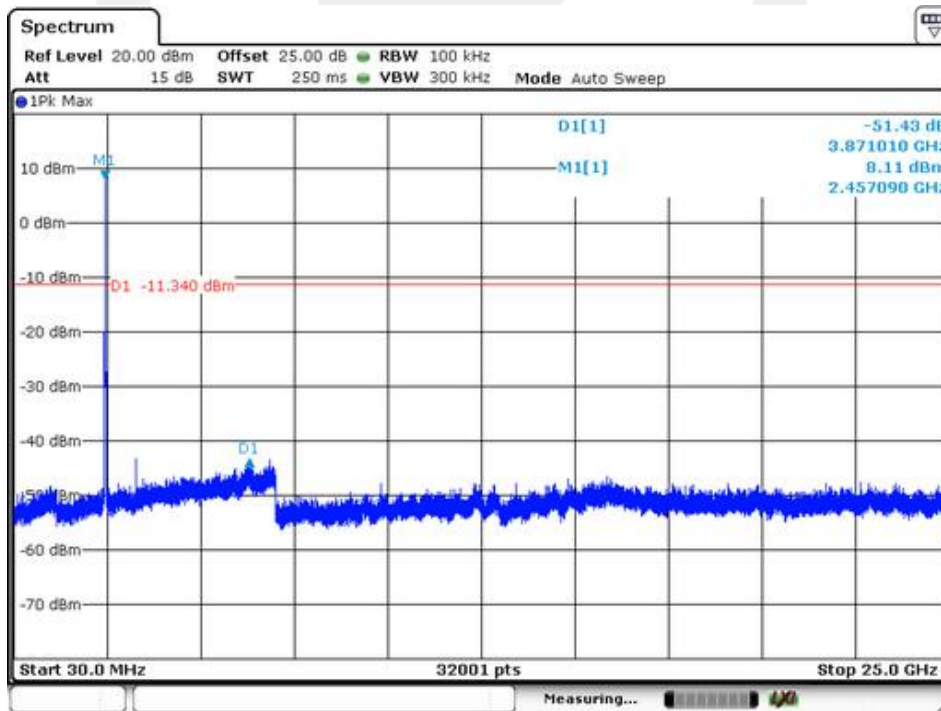

Highest Channel



## Test Mode: IEEE 802.11n(HT20)

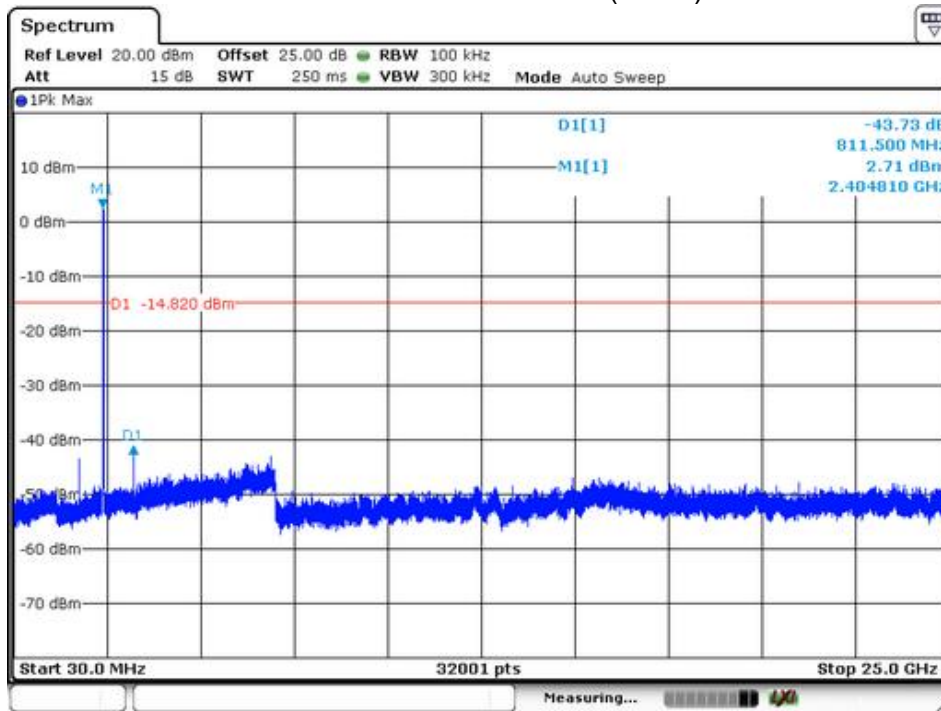

## Lowest Channel

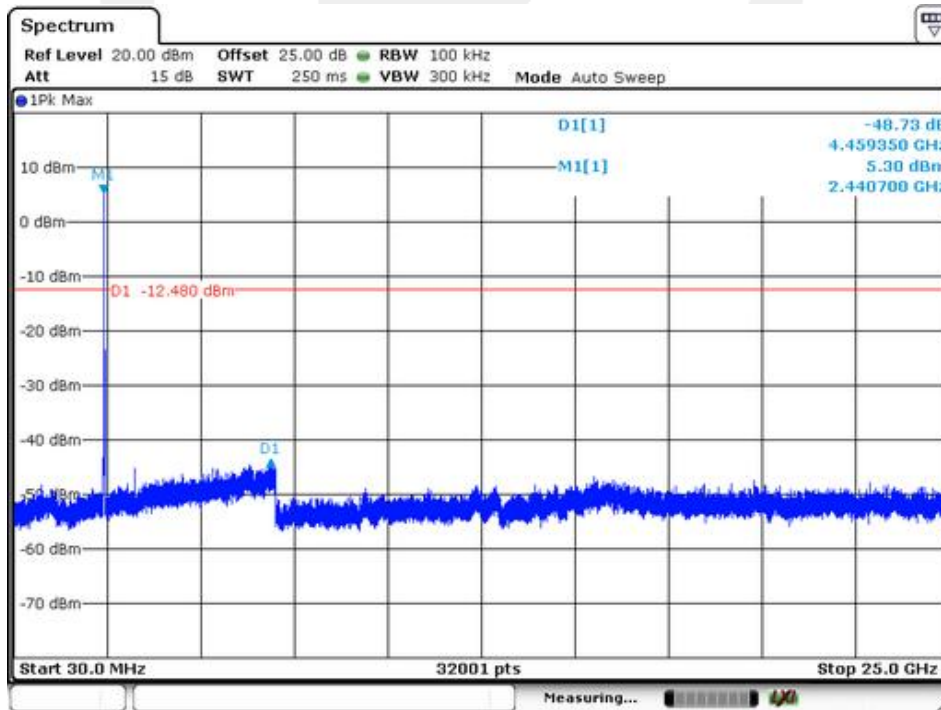

## Middle Channel

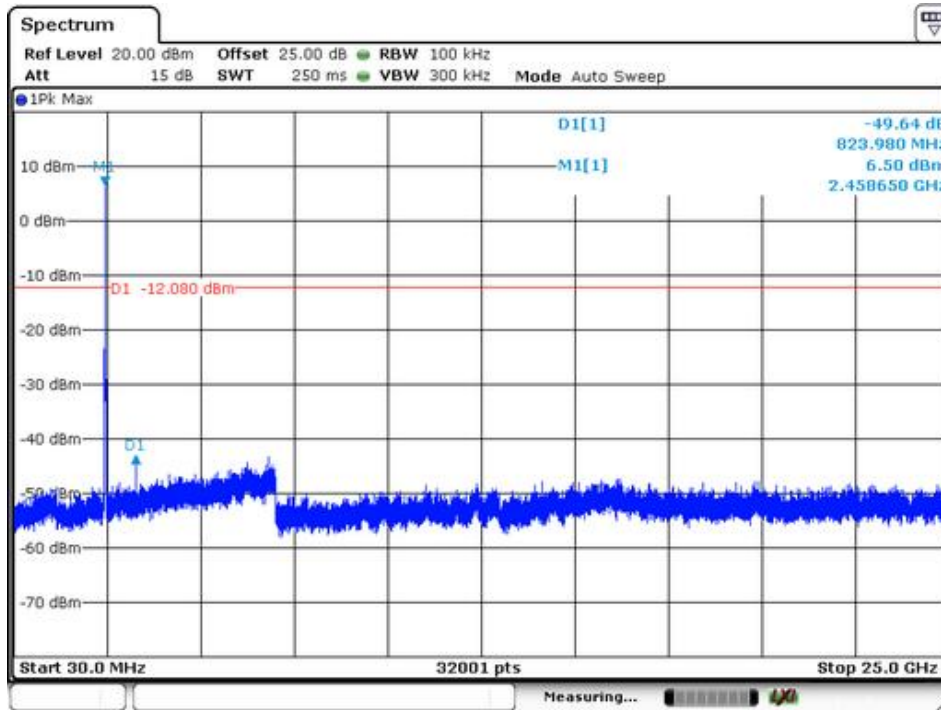

Highest Channel

Test Mode: IEEE802.11n(HT40)

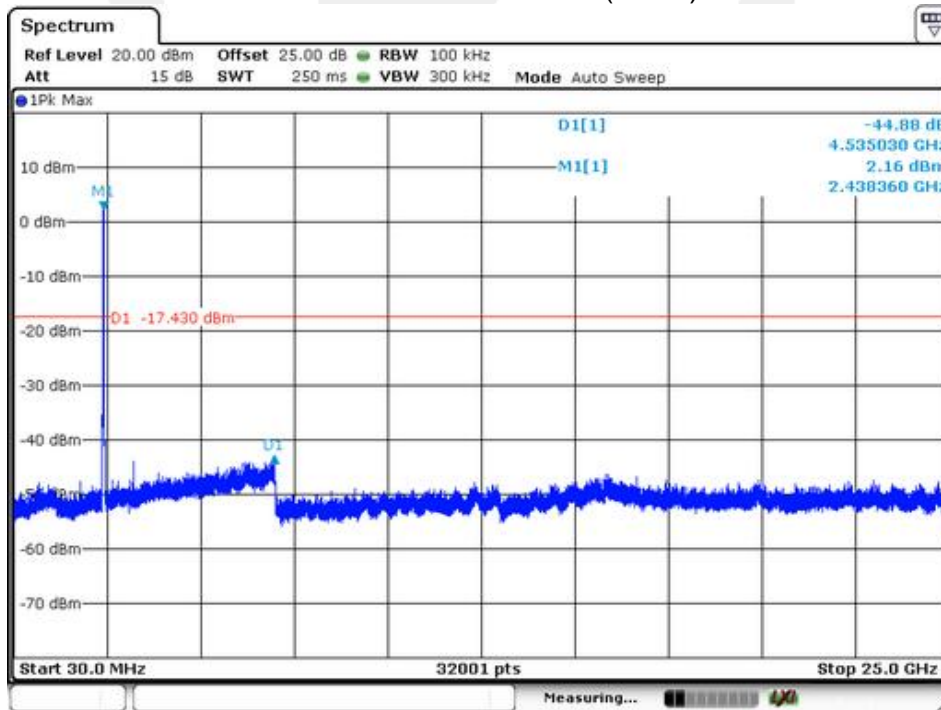

Lowest Channel

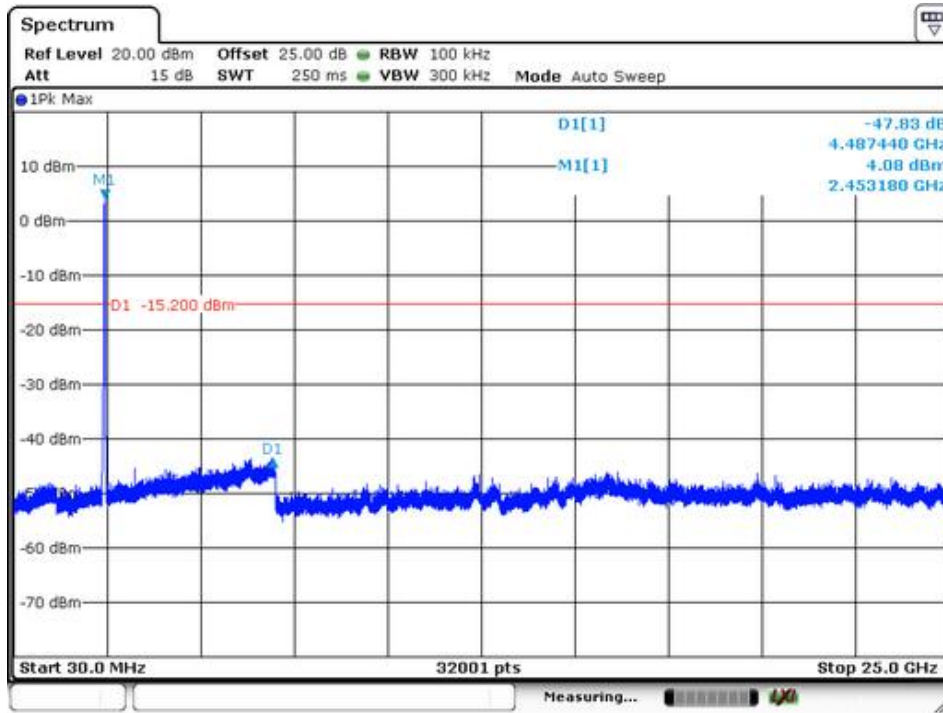

Middle Channel

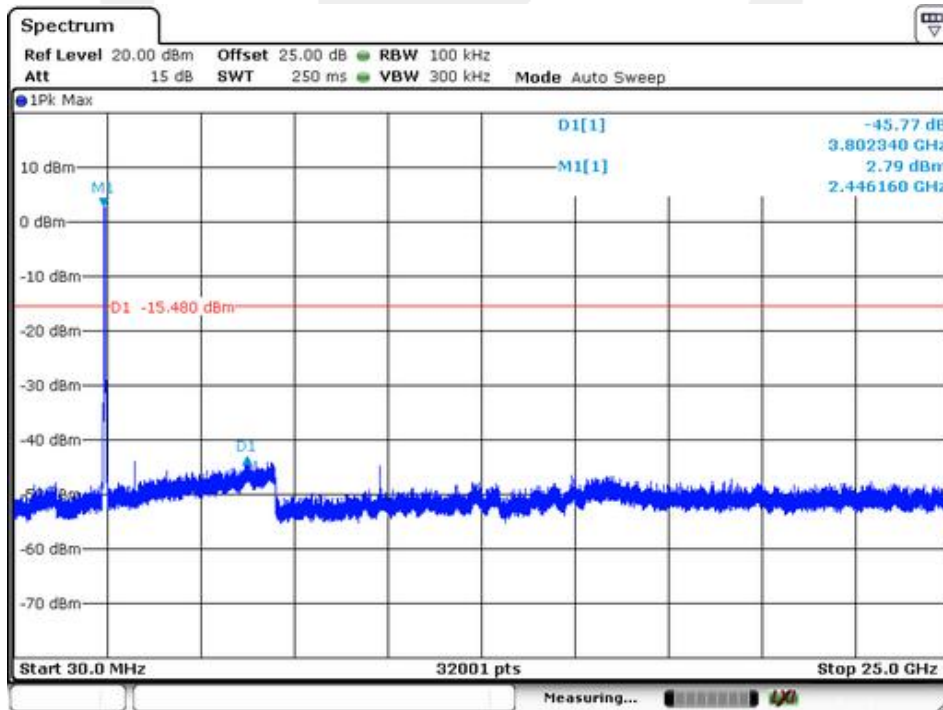

Highest Channel

## 15. Antenna Application

### 15.1 Antenna Requirement

For intentional device, according to FCC 47 CFR Section 15.203, an intentional radiator shall be designed to ensure that no antenna other than that furnished by the responsible party shall be used with the device. And according to FCC 47 CFR Section 15.247 (b), if transmitting antennas of directional gain greater than 6dBi are used, the power shall be reduced by the amount in dB that the directional gain of the antenna exceeds 6dBi.

### 15.2 Result

The EUT'S antenna, permanent attached antenna, is internal antenna. The antenna's gain is 2dBi and meets the requirement.



# APPENDIX I (PHOTOS OF EUT)









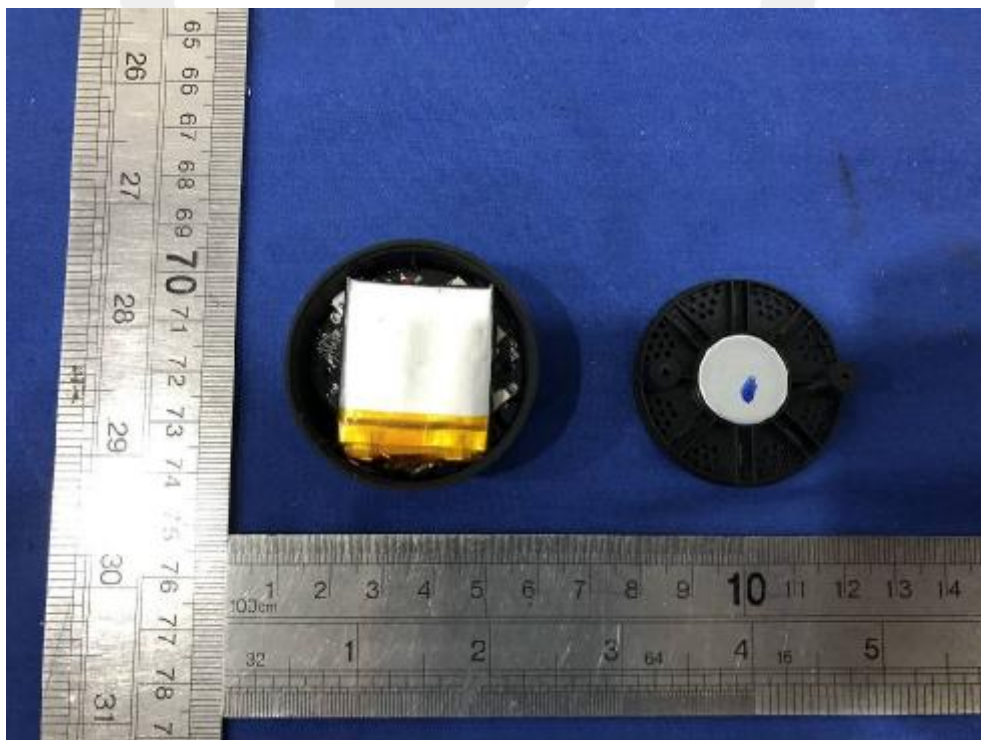

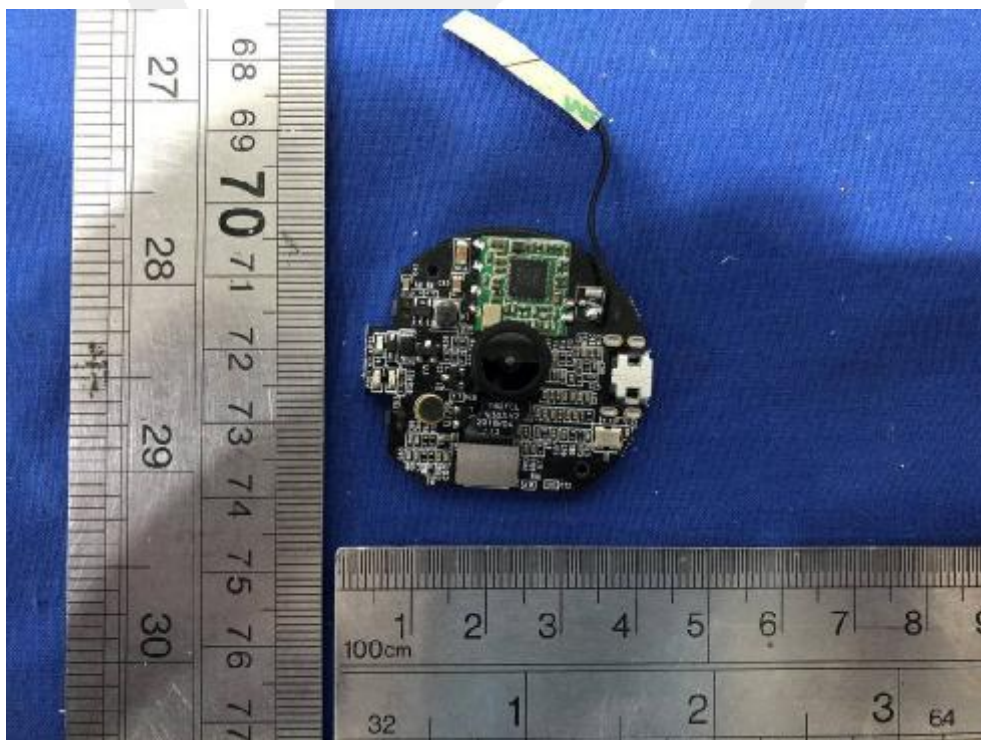
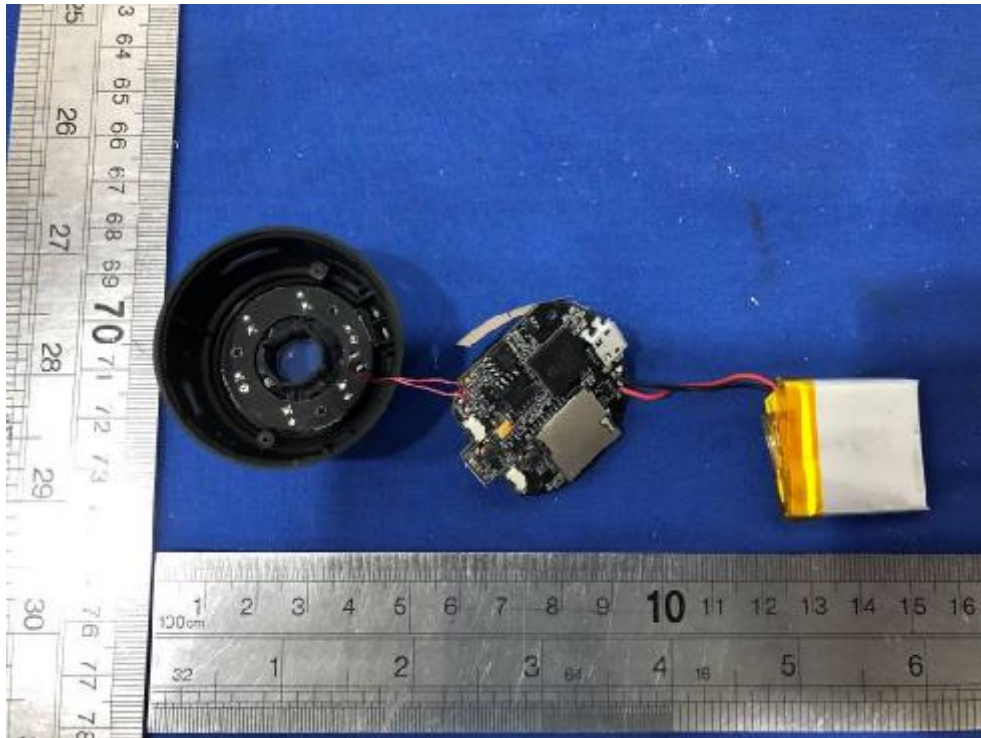



\*\*\* End of Report \*\*\*

# 声明 Statement

1. 本报告无授权批准人签字及“检验报告专用章”无效；  
This report will be void without authorized signature or special seal for testing report.
2. 未经许可本报告不得部分复制；  
This report shall not be copied partly without authorization.
3. 本报告的检测结果仅对送测样品有效，委托方对样品的代表性和资料的真实性负责；  
The test results or observations are applicable only to tested sample. Client shall be responsible for representativeness of the sample and authenticity of the material.
4. 本检测报告中检测项目标注有特殊符号则该项目不在资质认定范围内，仅作为客户委托、科研、教学或内部质量控制等目的使用；  
The observations or tests with special mark fall outside the scope of accreditation, and are only used for purpose of commission, research, training, internal quality control etc.
5. 本检测报告以实测值进行符合性判定，未考虑不确定度所带来的风险，本实验室不承担相关责任，特别约定、标准或规范中有明确规定的除外；  
The test results or observations are provided in accordance with measured value, without taking risks caused by uncertainty into account. Without explicit stipulation in special agreements, standards or regulations, EMTEK shall not assume any responsibility.
6. 对本检测报告若有异议，请于收到报告之日起 20 日内提出；  
Objections shall be raised within 20 days from the date receiving the report.