



Enabling Industrial IoT



QUARTZ-ONYX 5G NR Gigabit Ethernet Industrial Router Range

Hardware Reference Manual Rev
1.3

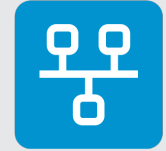
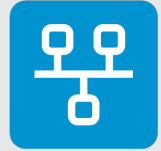

Table of Contents

	Page		Page
Introduction	3	Copyright Information	44
About Siretta	4	Copyright Declarations	44
General Description	5	Trademarks	44
Typical Installation	6	Approvals	45
Features	7	Disclaimer	46
Specifications	10	Definitions	47
Ordering Information	16		
Radio Characteristics	17		
WiFi Characteristics	17		
Cellular Characteristics	19		
GPS Characteristics	22		
Dimensions	23		
Wall Mount Bracket	24		
QUARTZ-ONYX Images	25		
Status LEDs	27		
Interfaces	29		
LAN / WAN Port	30		
RS232 Interface	31		
GPIO	33		
Earth Point	35		
Reset	36		
SIM Socket	37		
Antenna Connectors	38		
Cellular Antenna Connector	38		
GPS Antenna Connector	40		
WiFi Antenna Connector	42		
Power	43		



Introduction

This document covers all the electrical and mechanical aspects of the QUARTZ-ONYX 5G NR router. For programming and use of this product in a computer network, please refer to the QUARTZ-ONYX Software Manual.

This manual is intended to guide on how to connect the QUARTZ-ONYX 5G NR router into a computer network so that it may be used as the gateway router either to a WAN or the 5G NR cellular network, with the option of automatic fallback between the two. For complete network configuration, it is necessary to set up the network using the built-in web server for which reference to the companion software manual is required.

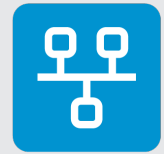

About Siretta

Siretta is a wireless communications company located in Reading, United Kingdom manufacturing & supplying industrial IoT products since the early 2000s.

Siretta's product portfolio is made up of:

- » Antennas, plus their associated Cable Assemblies & Adapters,
- » Cellular Network Analysers
- » Industrial Modems
- » Industrial Routers
- » Associated Cloud Management

Siretta supplies products directly and via a worldwide network of distributors, into numerous markets and applications across the globe.

Siretta's distribution partners range from industrial IoT specialists through to global catalogue organisations.

Whether "off the shelf" or custom solutions are required, Siretta has a wide portfolio of products to fit many types of application.

Siretta's extensive knowledge and experience in the wireless market allows support of a wide range of customer applications, focusing on frequencies between 150 MHz to 6 GHz. These encompass modems, routers and antennas for:

- » Cellular technologies: GSM/GPRS/3G/UMTS/4G/LTE & 5G NR, plus LTE CAT 1, LTE CAT M & LTE CAT NB-IoT
- » Global positioning: GPS/GNSS
- » WLAN/Wi-Fi

Whilst providing the above products for the industrial cellular market, Siretta also has a number of antennas to cover applications for:

- » Bluetooth, Zigbee, ISM band, LoRa and Sigfox

With a heavy emphasis on design, Siretta has a team of dedicated Engineers and Product Managers, who specialise in wireless applications.

Siretta continually makes significant investment in R&D endeavouring to provide customers with market leading, future-proofed, wireless solutions. Siretta works closely with many technology partners to stay at the forefront of industrial IOT.

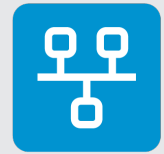

General Description

The QUARTZ-ONYX uses a Mediatek 880 MHz MIPS dual-core processor with 256 Mb flash and 2 Gb of DDR3 RAM. This processor runs a proprietary Operating System based on Linux which controls the web interface and routing functionality of the router. VPN throughput is enhanced with a hardware IPSec crypto engine onboard the MIPS processor. The processing system is augmented with an STM32 ARM Cortex coprocessor which controls the operation of the GPIO and serial interfaces.

The cellular capabilities of the QUARTZ-ONYX are powered by the Quectel RM500 QAE Module which uses the Qualcomm Snapdragon X55 5G Modem and is manufactured on a leading edge 7 nm semiconductor fabrication process. Dual SIM operation provides cellular network resilience when there may be connectivity issues.

As well as offering four Gigabit Ethernet interfaces, the QUARTZ-ONYX also offers RS232 and RS485 interfaces that may be used to connect serial ports on products such as door access controllers and alarm panels to the Internet. Further peripheral connectivity is provided by an intelligent GPIO interface that can send SMS messages on change of input state, and control outputs based on input state or SMS messages received.

WiFi 5 comes as standard, and the QUARTZ-ONYX also optionally supports GPS using a 56-channel u-blox 7 engine for asset tracking applications.

Three modes of networking operation are possible:

1. 5G NR cellular router where the WAN connection of the router is the 5G NR cellular interface. In this mode all Ethernet interfaces are for LAN use. Internet connectivity comes from the internal cellular interface.
2. WAN router where one of the Ethernet ports of the router is used as the WAN connection. The WAN port in this case would normally be connected to a cable or ADSL modem to obtain Internet connectivity.
3. Backup router which combines the two above modes. The router can switch between the cellular and WAN connections automatically to maintain Internet connectivity should one path fail. The preferred route can be set to cellular or WAN.

Typical Installation

This section explains the interfaces on the QUARTZ-ONYX and how to connect to them. It is recommended that the SIM card necessary for Cellular operation into the QUARTZ-ONYX be inserted first and power applied last.

A typical installation will look like this:

Figure 1. Typical system diagram

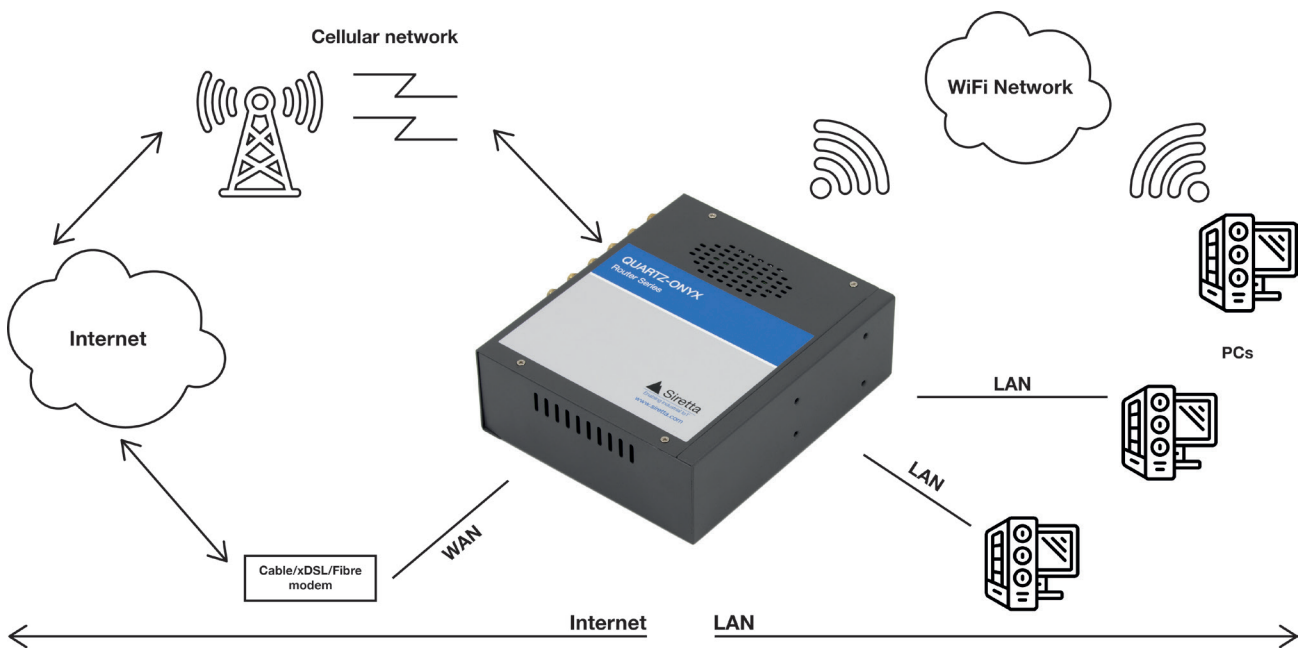

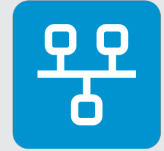

Features

Physical Interfaces

- » 4x Gigabit RJ-45 Ethernet Interfaces
- » 2x SIM Slots
- » 1x DC Power Interface (7.5 to 32 V dc)
- » 5x SMA Cellular antenna Interface (4x cellular, 1x GPS on models supporting GPS)
- » 2x RP-SMA Wi-Fi Interface
- » Serial interface that may be configured as 2x RS232 or 1x RS485/Modbus
- » 2x Digital Inputs, with programmable noise filter
- » 2x Digital Outputs that can be set high, low or to pulse when activated

WiFi Features

- » IEEE 802.11n/ac radio supporting IEEE 802.11 a/b/g/n/ac wireless standards
- » Concurrently operates in 2.4 and 5 GHz bands
- » Standard Reverse Polarity SMA antenna interface
- » Access point, Client, and Ethernet bridge modes of operation
- » 20/40/80 MHz channel width

LAN/WAN Features

- » 3x Gigabit LAN & 1x Gigabit LAN/WAN (user configurable)
- » Hardware NAT capable of 2 Gbps wire speed
- » Auto-MDI/MDIX

Cellular Features

- » Support for 5G NR (NSA & SA), LTE (4G) and WCDMA (3G) networks
- » Dual SIM operation with failover and backup modes
- » Network locking
- » Network disconnection checking



5G NR Features

- » Supports 3GPP Release 15 features
- » Supports NSA (Non-Standalone Architecture) and SA (Standalone Architecture) modes of operation
- » Supports FDD and TDD modes
- » Supports Frequency Range 1 bands (Sub 6 GHz bands)
- » MIMO support
- » Maximum downlink speed 2.1 Gbps (SA mode); 2.5 Gbps (NSA mode)
- » Maximum uplink speed 450 Mbps (SA mode); 650 Mbps (NSA mode)

LTE (4G) Features

- » Supports Cat 16 download and Cat 18 upload speeds
- » Supports FDD and TDD modes
- » Supports MIMO in download direction
- » Maximum downlink speed 1.0 Gbps
- » Maximum uplink speed 200 Mbps

WCDMA (3G) Features

- » Supports GPS constellation
- » Client and server modes of operation
- » 10 Hz update rate
- » NMEA 0183 & proprietary M2M format supported
- » Cold start time to first fix typically 29 seconds
- » TCXO oscillator for high performance
- » Active antenna support

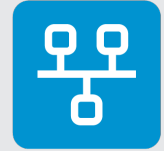

GPS Features

- » Supports GPS constellation
- » Client and server modes of operation
- » 10 Hz update rate
- » NMEA 0183 & proprietary M2M format supported
- » Cold start time to first fix typically 29 seconds
- » TCXO oscillator for high performance
- » Active antenna support

VPN Features

- » Hardware Crypto Engine delivering 400~500 Mbps IPSec throughput

LED Indication

- » Power – Power applied
- » Cellular Signal – signal quality & connection status
- » LAN – connection status and activity
- » WAN – connection status and activity
- » WLAN – connection status and activity
- » Error – Cellular online/offline status

Physical

- » Galvanised steel box with grounding point
- » Wide operating temperature range
- » Supplied with DIN rail adapter (with accessories version only)
- » Supplied with mounting plate to attach to a flat surface such as a wall or cabinet (with accessories version only)

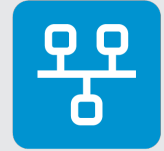

Specifications

Physical

Environmental

Table 1. Environmental Characteristics

Parameter	Value
Operating Temperature	-30 to +75°C
Storage Temperature	-40 to +85°C
Humidity Range	0 to 95% RH non-condensing

Mechanical

Table 2. Mechanical Characteristics

Parameter	Value
Dimensions	132 mm x 112 mm x 44 mm (excluding protruding connectors)
Weight	472g (excluding antennas, SIM card, connectors and packaging)
IP Rating	30

Power

Power Supply Requirements

Table 3. Power Supply Requirements

Parameter	Value
Input supply voltage	7.5 – 32 V
Minimum power supply rating	24 W
Recommended Power Supply	12 V @ 2.0 A

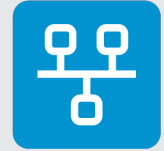

Power consumption

Table 4. Power Consumption Characteristics

Features Enabled					Average current when powered from 12V
Cellular	WiFi	WAN	LAN	GPS	
●	●	●	●	●	680 mA
●	●	●	●		630 mA
●	●	●			630 mA
●	●				580 mA
●			●		550 mA
●			●		680 mA*

*When streaming BBC iPlayer at highest video quality

IMPORTANT: Power consumption currents are measurements of average current. When the cellular connection is active there will be short current pulses significantly greater than the average values provided. It is important that the 12V supply used to power the router can deliver at least 2.0 A to prevent network disconnections caused by these current pulses.

All current measurements with the cellular modem enabled are started after the router has obtained an IP address from the cellular network and is in a steady state. An 800 MHz LTE cell with a measured signal strength of 15 was used when taking measurements. Measurements for all communication interfaces are with them enabled and connected but no traffic flowing. WiFi is used with both 2.4G and 5G enabled. LAN power measurements are made with a single LAN port used. GPS is measured after a position fix has been obtained.

IMPORTANT: BBC iPlayer may be accessed at <https://www.bbc.co.uk/iplayer>. Much content could be blocked outside of the UK, but BBC news is always likely to be available internationally.

The power consumption when used with UMTS, LTE and 5G NR networks is broadly similar. Cellular power consumption will be affected will be affected more strongly by proximity to the serving cell (closer to the cell = less transmitting power required), weather (heavy rain/snow = more signal attenuation and greater transmit power) and operating band (lower frequencies are generally lower power).

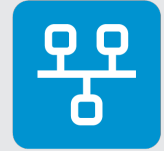

Dual Sim Card reader

Dual SIM card reader for mini-SIM (2FF) meeting ISO/IEC 7810:2019, ID-000 (25 mm x 15 mm)

Table 5. SIM Card Reader Characteristics

Parameter	Value
SIM card reader type	Push-Pull
SIM card voltage support	1.8 V and 3 V with automatic detection

RS232 characteristics

The RS232 port is 2-wire (no flow control). The RS232 port may be used in either client or server mode (server mode requires either a fixed IP address SIM or a VPN to be configured). Caching of serial data is supported for areas where Internet access is intermittent. The QUARTZ-ONYX may be set to either RS232 (two ports) or RS485 (one port). Selection between RS232 and RS485 is made in software on the router configuration pages.

Table 6. RS232 Configuration Settings

Setting	Allowed Values
Baud Rate	300, 600, 1200, 2400, 9600, 19200, 38400, 57600, 115200
Data bits	5, 6, 7, 8
Parity	None, odd, even
Stop bits	1, 2

IMPORTANT: Baud rates settings are valid with a load of 3k Ω , 1000pF

Table 7. RS232 Transmitter Characteristics

Transmitter Parameter	Conditions	Min	Typ	Max	Units
Output Voltage Swing	3k Ω load to ground	± 5.0	± 5.4		Volts
Output short circuit current			± 35	± 60	mA

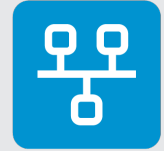

Table 8. RS232 Receiver Characteristics

Receiver Parameter	Min	Typ	Max	Units
Voltage Range	-15		15	Volts
Threshold Low	0.6	1.3		Volts
Threshold High		1.7	2.4	Volts
Hysteresis		0.3		Volts
Resistance	3	5	7	k Ω

IMPORTANT: Minimum and maximum values are over the operating temperature range of -30 to +75°C, typical values are at +25°C.

RS485 characteristics

The RS485 port may be used in either client or server mode (server mode requires either a fixed IP address SIM or a VPN to be configured). The QUARTZ-ONYX may be set to either RS232 (two ports) or RS485 (one port). Selection between RS232 and RS485 is made in software on the router configuration pages.

Table 9. RS485 Configuration Settings

Setting	Allowed Values
Baud Rate	300, 600, 1200, 2400, 9600, 19200, 38400, 57600, 115200
Data bits	5, 6, 7, 8
Parity	None, odd, even
Stop bits	1, 2

Table 10. RS485 Driver Characteristics

Transmitter Parameter	Conditions	Min	Typ	Max	Units
Differential Output Voltage	Unloaded, load = ∞			3.47	Volts
Differential Output Voltage	Loaded, Load = 27 Ω	1.5			Volts
Change in magnitude of driver differential output voltage for complimentary states	Load = 27 Ω			0.2	Volts
Common Mode Output Voltage	Load = 27 Ω			3.0	Volts
Output short circuit current				\pm 250	mA

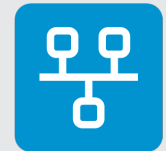

Table 11. RS485 Receiver Characteristics

Receiver Parameter	Conditions	Min	Typ	Max	Units
Differential Input Threshold	$-7V \leq VCM \leq 12V$	-0.2		0.2	Volts
Input Hysteresis	$VCM = 0V$		0.02		Volts
Input Resistance	$-7V \leq VCM \leq 12V$	12			k Ω

IMPORTANT: Minimum and maximum values are over the operating temperature range of -30 to +75°C.

LAN characteristics

4x 10/100/1000 Mbps Ethernet RJ45 Ports. Three ports are for LAN only. The fourth port may be software configured as a LAN or a WAN port. Although the maximum speed if any individual port is 1 Gbps, the switching matrix supporting the 4 ports is capable of 2 Gbps wire speed.

GPIO Characteristics

DI1 and DI2 are voltage level triggered inputs. DI1 is internally pulled down to 0 V using a 94K Ω resistor. DI2 is internally pulled up to 5 V using a 4700 Ω resistor, but not designed to source any current if not used as an input. It is acceptable to leave these inputs disconnected if not used.

Table 12. Input Pin Characteristics

Parameter	Conditions	Min	Typ	Max	Units
Absolute maximum input voltage	25°C Ambient	-10.0		5.0	Volts
Input threshold low	25°C Ambient			0.5	Volts
Input threshold high	25°C Ambient	3.0			Volts
Input resistance DI1	25°C Ambient	16.45	23.5	30.55	k Ω
Input resistance DI2	25°C Ambient	3.65	3.92	4.07	k Ω

IMPORTANT: Operation outside of the maximum operating voltage range will cause damage to the router.

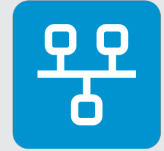

Table 13. Output Pin Characteristics

Parameter	Conditions	Min	Typ	Max	Units
Output voltage low	Load = +32 mA			0.55	Volts
Output voltage high	Load = -32 mA	3.8			Volts
Recommended load current		0		±32	mA
Absolute maximum output current				±50	mA

IMPORTANT: All output characteristics are over the operating temperature range of -30 to +75°C.

The power up default state of each output can be set using the routers home page.



Ordering Information

Dual WiFi & GPS Industrial 5G Quad Gigabit Ethernet Router

QUARTZ-ONYX-GW42-5G (GL) - Stock Code 61831

QUARTZ-ONYX-GW42-5G (GL) + ACCESSORIES - Stock Code 61870

Dual WiFi Industrial 5G Quad Gigabit Ethernet Router

QUARTZ-ONYX-W42-5G (GL) – Stock code 61818

QUARTZ-ONYX-W42-5G (GL) + ACCESSORIES - Stock Code 61816

The accessories kit contains all the other components required to be able to use the router:

- » 2 swivel joint WLAN antennas
- » 4 swivel joint Cellular antennas supplied with detachable magnetic mount bases with 3m of cable
- » GPS antenna (GPS models only)
- » RJ45 Ethernet cable
- » DIN rail mounting kit
- » Wall mounting kit
- » Multi-region 2A, 12V power supply

Both versions of the router may be ordered with optional internal storage of 16, 32, 64, 128 or 256 GB. This can be useful if the Captive Portal feature is being used. Please contact sales for details (Minimum order quantity 50 pieces).

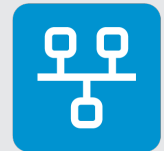

Radio Characteristics

WiFi Characteristics

The Quartz-ONYX supports WiFi using a MediaTek radio that is IEEE802.11n/ac compliant. This means that it will work with other WiFi adapters supporting IEEE 802.11a/b/g/n/ac. The 2.4 GHz and 5 GHz wireless bands may be independently configured.

2.4 GHz bands may be set to 20 or 40 MHz channel width.

5 GHz bands may be set to 20, 40 or 80 MHz channel width.

A channel configured for 2.4 GHz operation may be used as 802.11b only, 802.11g only, 802.11b/g mixed and 802.11n only, as well as the default 802.11b/g/n mixed mode (configured by software).

A channel configured for 5 GHz operation can be used as 802.11a only and 802.11n only, as well as the default 802.11ac mixed mode (configured by software).

WiFi Channels Supported

Table 14. 2.4 GHz WiFi band support

Channel Number	Centre frequency	Frequency Range
1	2412 MHz	2401 – 2423 MHz
2	2417 MHz	2406 – 2428 MHz
3	2422 MHz	2411 – 2433 MHz
4	2427 MHz	2416 – 2438 MHz
5	2432 MHz	2421 – 2443 MHz
6	2437 MHz	2426 – 2448 MHz
7	2442 MHz	2431 - 2453 MHz
8	2447 MHz	2436 – 2458 MHz
9	2452 MHz	2441 – 2463 MHz
10	2457 MHz	2446 – 2468 MHz
11	2462 MHz	2451 – 2473 MHz
12	2467 MHz	2456 – 2478 MHz
13	2472 MHz	2461 – 2483 MHz
14	2484 MHz	2473 – 2495 MHz

IMPORTANT: While the QUARTZ-ONYX can support all 2.4 GHz WiFi channels, the regional settings in the WiFi configuration page will limit the available channels to meet the regulatory requirements of the country in which it is being used. Siretta always recommends that the region setting be correctly configured for the country in which the router is being used.

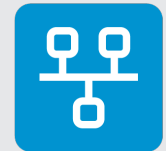
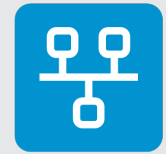

Table 15. 5 GHz WiFi support

Channel Number	Centre frequency	Frequency Range
36	5.18 GHz	5.17 – 5.19 GHz
40	5.20 GHz	5.19 – 5.21 GHz
44	5.22 GHz	5.21 – 5.23 GHz
48	5.24 GHz	5.23 – 5.25 GHz
52	5.26 GHz	5.25 – 5.27 GHz
56	5.28 GHz	5.27 – 5.29 GHz
60	5.30 GHz	5.29 – 5.31 GHz
64	5.32 GHz	5.31 – 5.33 GHz
100	5.50 GHz	5.49 – 5.51 GHz
104	5.52 GHz	5.51 – 5.53 GHz
108	5.54 GHz	5.53 – 5.55 GHz
112	5.56 GHz	5.55 – 5.57 GHz
116	5.58 GHz	5.57 – 5.59 GHz
120	5.60 GHz	5.59 – 5.61 GHz
124	5.62 GHz	5.61 – 5.63 GHz
128	5.64 GHz	5.63 – 5.65 GHz
132	5.66 GHz	5.65 – 5.67 GHz
136	5.68 GHz	5.67 – 5.69 GHz
140	5.70 GHz	5.69 – 5.71 GHz

IMPORTANT: While the QUARTZ-ONYX can support most 5 GHz WiFi channels, the regional settings in the WiFi configuration page will limit the available channels to meet the regulatory requirements of the country in which it is being used. The regional setting also correctly applies transmit power and DFS requirements for the country of use. Siretta always recommends that the region setting be correctly configured for the country in which the router is being used.



WiFi Speed

Mode	Speed
2.4G only	150 Mbps
5G only	433 Mbps
2.4G + 5G	150 Mbps + 433 Mbps

Cellular Characteristics

The QUARTZ-ONYX supports the 3GPP specifications for cellular communications by using the Qualcomm Snapdragon X55 5G Modem.

Cellular Frequency bands supported

Table 16. 5G NR SA and NSA Bands Supported

Band	Frequency	Duplex Mode	Common Name	4X4 MIMO DL	2x2 MIMO UL
n1	2100 MHz	FDD	IMT	●	●
n2	1900 MHz	FDD	PCS	●	●
n3	1800 MHz	FDD	DCS	●	●
n5	850 MHz	FDD	Cellular	●	●
n7	2600 MHz	FDD	IMT-E	●	●
n8	900 MHz	FDD	Extended GSM	●	●
n12	700 MHz	FDD	Lower SMH	●	●
n20	800 MHz	FDD	Digital Dividend	●	●
n25	1900 MHz	FDD	Extended PCS	●	●
n28	700 MHz	FDD	APT	●	●
n38	2600 MHz	TDD	IMT-E	●	●
n40	2300 MHz	TDD	S-Band	●	●
n41	2500 MHz	TDD	BRS	●	●*
n48	3500 MHz	TDD	CBRS	●	●
n66	1700 MHz	FDD	Extended AWS	●	●
n71	600 MHz	FDD	Digital Dividend	●	●
n77	3700 MHz	TDD	C-Band	●	●
n78	3500 MHz	TDD	C-Band	●	●
n79	4700 MHz	TDD	C-Band	●	●

*SA mode only

● Supported ● Unsupported

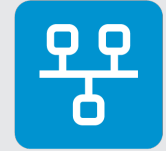

Table 17. LTE Bands Supported

Band	Frequency	Duplex Mode	Common Name	4X4 MIMO DL
1	2100 MHz	FDD	IMT	●
2	1900 MHz	FDD	PCS	●
3	1800 MHz	FDD	DCS	●
4	1700 MHz	FDD	AWS-1	●
5	850 MHz	FDD	Cellular	●
7	2600 MHz	FDD	IMT-E	●
8	900 MHz	FDD	Extended GSM	●
12	700 MHz	FDD	Lower SMH	●
13	700 MHz	FDD	Upper SMH	●
14	700 MHz	FDD	Upper SMH	●
17	700 MHz	FDD	Lower SMH	●
18	850 MHz	FDD	Lower 800	●
19	850 MHz	FDD	Upper 800	●
20	800 MHz	FDD	Digital Dividend	●
25	1900 MHz	FDD	Extended PCS	●
26	850 MHz	FDD	Extended Cellular	●
28	700 MHz	FDD	APT	●
29	700 MHz	FDD	Lower SMH	●
30	2300 MHz	FDD	WCS	●
32	1500 MHz	FDD	L-Band	●
34	2000 MHz	TDD	IMT	●
38	2600 MHz	TDD	IMT-E	●
39	1900 MHz	TDD	DCS-IMT Gap	●
40	2300 MHz	TDD	S-Band	●
41	2500 MHz	TDD	BRS	●
42	3500 MHz	TDD	CBRS	●
43	3700 MHz	TDD	C-Band	●
46 (LAA*)	5200 MHz	TDD	U-NII-1-4	●
48	3500 MHz	TDD	CBRS	●

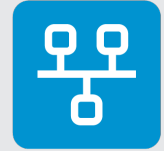

Table 17. LTE Bands Supported continued

Band	Frequency	Duplex Mode	Common Name	4X4 MIMO DL
66	1700 MHz	FDD	Extended AWS	●
71	600 MHz	FDD	Digital Dividend	●

*LAA (License Assisted Access). A method of using the unregulated 5 GHz wireless spectrum to assist data downloads, introduced in 3GPP Release 13.

Table 18. WCDMA (3G) Bands Supported

Band	Frequency	Common Name
1	2100 MHz	IMT
2	1900 MHz	PCS
3	1800 MHz	DCS
4	1700 MHz	AWS-1
5	850 MHz	Cellular
6	800 MHz	UMTS 800
8	900 MHz	Extended GSM
19	800 MHz	Upper 800

Transmit Power

Table 19. Transmit Power

Technology	Class	Maximum Power
5G NR bands	3	23 dBm \pm 2 dB
5G NR bands n41, n77, n78 & n79 HPUE*	2	26 dBm +2/-3 dB
LTE (4G) bands	3	23 dBm \pm 2 dB
LTE (4G) bands 38, 40, 41, 42, 43 HPUE*	2	26 dBm \pm 2 dB
WCDMA (3G) bands	3	24 dBm +1/-3 dB

*HPUE (High Power User Equipment) is a special class of LTE allowed on a single carrier. Because of the higher allowed transmit power, this allows for a greatly increased range for the serving cell.

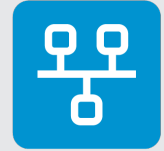

Supported Modulation

Table 20. Modulation

Technology	Supported Modulation
5G NR Uplink	$\pi/2$ -BPSK, QPSK, 16QAM, 64QAM and 256QAM
5G NR Downlink	QPSK, 16QAM, 64QAM and 256QAM
LTE (4G) Uplink	QPSK, 16QAM, 64QAM and 256QAM
LTE (4G) Downlink	QPSK, 16QAM, 64QAM and 256QAM
WCDMA (3G)	QPSK, 16QAM and 64QAM

Data Transmission Rates

Table 21. Data Transmission Rates

Technology	Maximum Download	Maximum Upload
5G NR SA	2.1 Gbps	450 Mbps
5G NR NSA	2.5 Gbps	650 Mbps
LTE (4G)	1.0 Gbps	200 Mbps
UMTS (3G) DC-HSDPA	42 Mbps	
UMTS (3G) HSUPA		5.76 Mbps
UMTS (3G) WCDMA	384 Kbps	384 Kbps

IMPORTANT: All upload and download speeds are those supported by the QUARTZ-ONYX. Actual speeds achieved will be dependent on the capabilities of the network cell connected to, any network congestion, and the radio link quality.

GPS Characteristics

IMPORTANT: This section is only applicable to models with the GPS option.

The GPS receiver in the QUARTZ-ONYX gives excellent positioning availability and accuracy.

Table 22. GPS

Technology	Description	Typical value
Sensitivity	Cold start	-146 dBm
	Reacquisition	-156 dBm
	Tracking	-165 dBm
Time To First Fix (TTFF)	Cold start with open sky	29 s
	Warm start with open sky	10 s
	Hot start with open sky	1 s
Accuracy (CEP-50)	Autonomous with open sky	<2.5 m

Wall Mount Bracket

Figure 6. Wall mount bracket

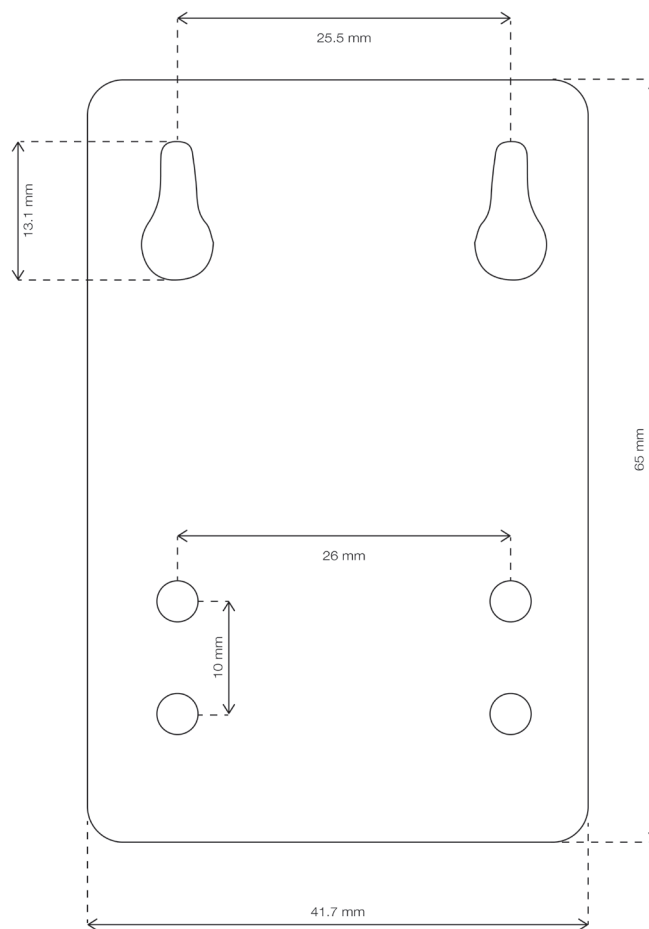

The wall mount bracket is only available as part of the accessories kit.

QUARTZ-ONYX Images

Figure 7. 3D view of the QUARTZ-ONYX Router



Figure 8. Front view of the QUARTZ-ONYX Router



Figure 9. Power, Reset, LED, Antenna, LAN / WAN Interfaces and GPIO



Figure 10. SIM Slot, Earth point, Terminal block

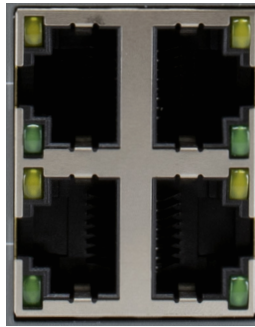

Figure 11. QUARTZ-ONYX accessories



- 1 QUARTZ-ONYX
- 2 Multi-head power adapter
- 3 Multi-region power adapter heads
- 4 DIN and wall mount bracket with screws
- 5 RJ-45 network cable
- 6 Power cable and GPIO connector
- 7 4G/5G antenna x4
- 8 2.4 GHz/ 5 GHz WiFi Antenna x2
- 9 Magnetic Cellular Antenna Extenders x4

Status LEDs

Signal 3		PWR	Yellow		Yellow
Signal 2		WLAN	Green		Green
			Yellow		Yellow
Signal 1		ERR	Green		Green

The status LEDs indicate activity on the QUARTZ-ONYXs interfaces. Note that the LED indication is not valid until the QUARTZ-ROUTER boots up, which takes approximately 30 seconds.

Table 23. Signal Strength and Router operation LEDs

Label	Indication		Meaning
Signal 1 Signal 2 Signal 3	Green	Solid	Signal strength bar graph when connected to the Internet. Read highest lit LED. Signal 3: Strong (CSQ 20-31) Signal 2: Good (CSQ 11-19) Signal 1: Weak (CSQ 0-10)
Signal 1	Green	Blinking Solid	Connected to cellular, obtaining IP address Online, connected to the Internet
PWR	Green	Off Solid	No power applied to QUARTZ-ONYX QUARTZ-ONYX powered
WLAN	Green	Off Blinking Solid	WLAN not enabled Data transfer in progress Enabled, no data transfer in progress
ERR	Red	Off Solid	Connected to Cellular network No cellular connection. See note below.

IMPORTANT: On first power up, it may take 4-5 minutes for the QUARTZ-ONYX to connect to the cellular network and for the ERR LED to go out. On subsequent power-ups it should only take 2-3 minutes to connect to the cellular network. If the ERR LED does not go out, check that the SIM card is inserted correctly, that the SIM is enabled by the network operator, that the correct APN and password settings have been entered (see QUARTZ-ONYX software manual), and that the antennas have been correctly attached.

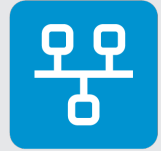

Table 24. WAN/ LAN LED functions

Label	Indication		Meaning
LAN & WAN	Green	Off	Not connected
		Blinking	Data transfer in progress
		Solid	Connected, no data transfer in progress
	Yellow	Off	LED not used

Interfaces

Use the pictures below to identify the interfaces of the QUARTZ-ONYX:

Figure 12. QUARTZ-ONYX interfaces

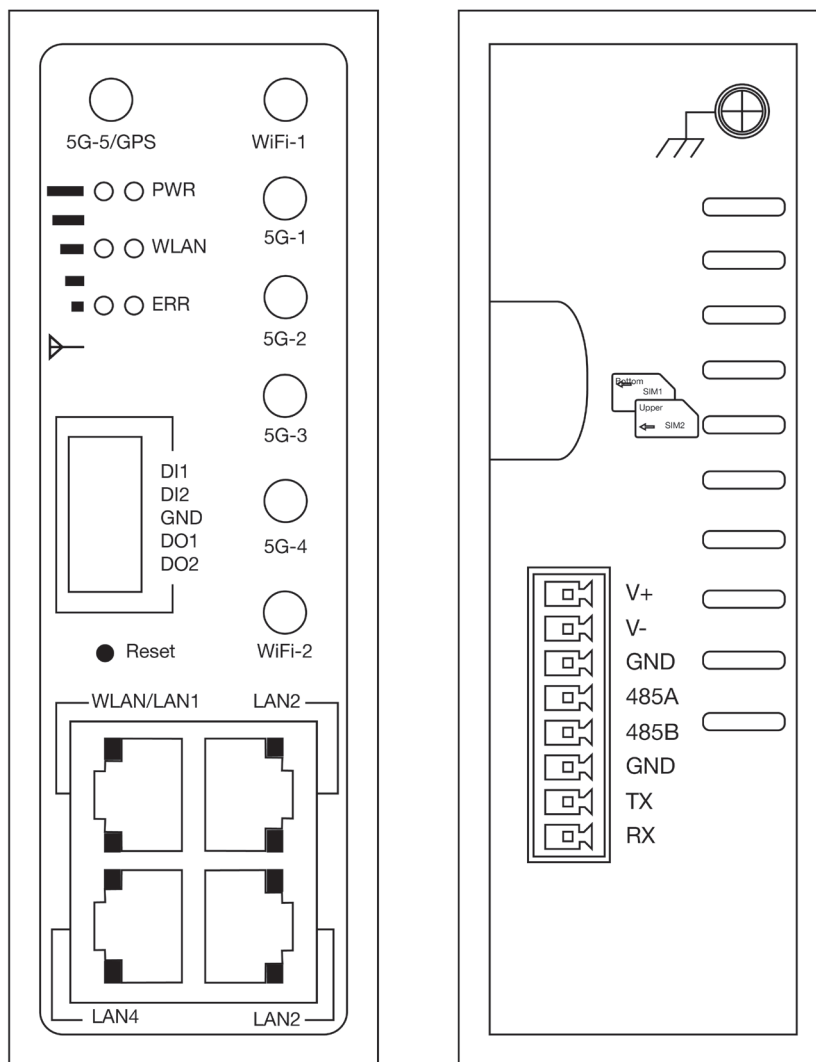

LAN/WAN Connectors

The WiFi requires two antennas with a 50 Ohm reverse polarity SMA connector meeting the following requirements:

Parameter	Value
VSWR	≤ 1.5
Minimum input power	1 W
Frequency range (2.4 GHz band)	2.4 to 2.5 GHz
Frequency range (5 GHz band)	5.15 to 5.85 GHz
Polarization	Vertical
Gain (2.4 GHz band)	3.0 dBi maximum*
Gain (5 GHz band)	3.0 dBi maximum*



Figure 13. LAN/WAN Connectors (GPS Version)



Figure 14. LAN/WAN Connectors (non-GPS version)

RS232/RS485 Interface

The RS232/RS485 interface shares the green connector with the power supply.

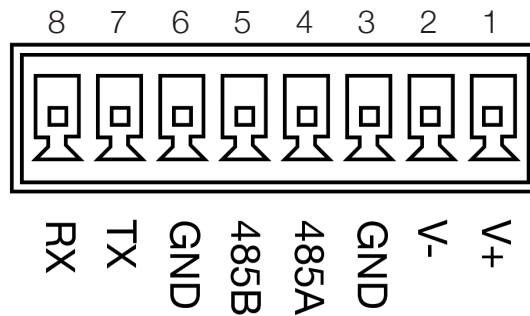

RS232/RS485 mode is selected using software configuration (See the Software User's Manual).

When configured as RS485, a single RS485 port is enabled using the pins used are shown below:

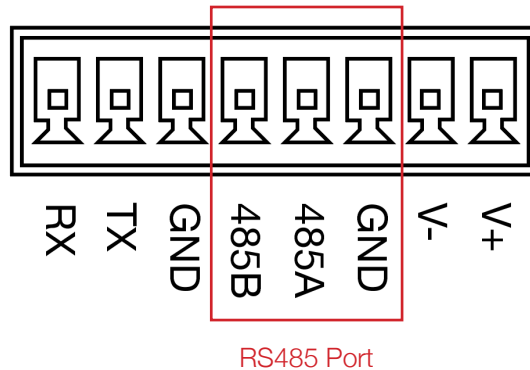

When configured as R232, the pins used are shown below:

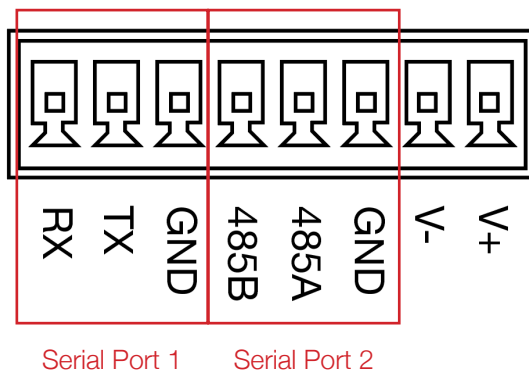



Pin	Label	Description
1	V+	Power positive
2	V-	Power negative
3	GND	RS232 Port 1 / RS485 ground
4	485A	RS232 Port 1 TX / RS485 A
5	485B	RS232 Port 1 RX / RS485 B
6	GND	RS232 Port 2 ground
7	TX	RS232 Port 2 TX
8	RX	RS232 Port 2 RX

GPIO

General

The GPIO terminal block on the QUARTZ-ONYX works with a 5-way connector from Phoenix Contact, part number 1881354.

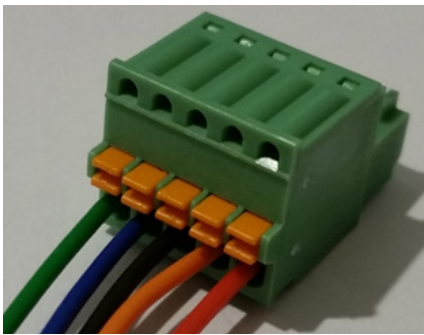

To connect wires to the connector, press in the orange-coloured button to open the jaws of the clamp below the button. Insert the wire and then stop pressing the button to close the jaws of the clamp.

The connector has polarizing lugs on it which prevent not only the connector from being plugged in incorrectly, but also prevent the use of connectors smaller than 5-way from being used.

Figure 15. Connector with signal wires attached

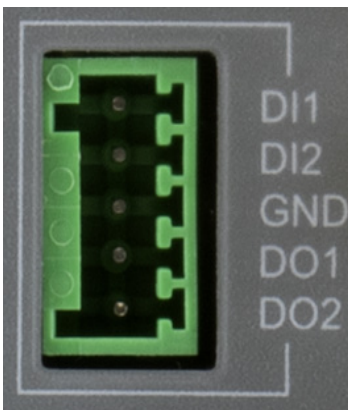

Figure 16. GPIO connections

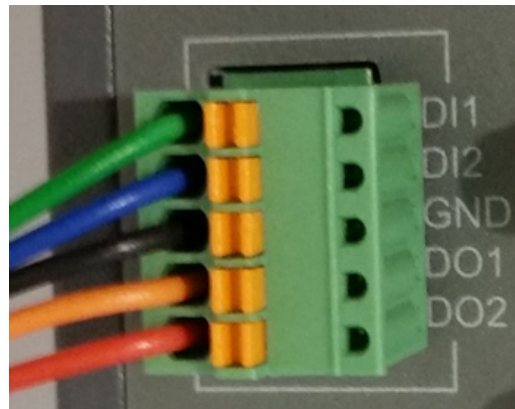
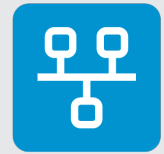

Figure 17. GPIO connector fitted

GND is ground (0 V) and is the reference for the digital inputs and outputs.



Outputs

Each output must be defaulted to be logic level high (5 V) or low (0 V) at power up. Both outputs are completely independent in their operation and settings.

The outputs may be programmed to change state on change of input or received SMS message. Change of state can be immediate or delayed by a programmable period of up to 30 seconds. Once triggered, the state change lasts for a programmable period up to 255 seconds before resetting. A state change can be a logic high, logic low, or a pulsing output of user defined mark space ratio.

When using SMS, to provide security the user must send the SMS from one of two user defined phone numbers with a user defined message otherwise the text message will be ignored by the QUARTZ-ONYX. Valid SMS messages are acknowledged by the QUARTZ-ONYX so that the user knows that the command has been received.

Inputs

Input DI1 and Input DI2 can be used to trigger the sending of an outgoing SMS message, or to trigger an output port. Both inputs are completely independent in their operation and settings.

Input DI1 has an internal pull-down resistor to ground and is triggered by being taken to 5V.

Input DI2 has an internal pull-up resistor to 5V and is triggered by being taken to 0V. Both inputs are digitally filtered to prevent spurious noise from causing the input to trigger. By default, a change of input state must persist for at least 100 mS to be recognised as a change of state. State changes shorter than this are ignored. This filter can be programmed to be up to 10 seconds in length should the application require it.

If used to generate a SMS, a user defined message is sent to up to two phone numbers. Third party applications could extend this feature by forwarding the SMS received from the QUARTZ-ONYX to other phone numbers or to email.

Earth Point

There is an earth point on the side of the QUARTZ-ONYX that may be used to earth the router. When the antennas are placed outside of a building it is recommended that the router be earthed as there is always a possibility that the antennas could be struck by lightning. Earthing the router is unlikely to prevent it from receiving catastrophic damage if an antenna receives a lightning strike but should prevent the surge continuing down wiring connected to the router. This reduces both the shock and the fire hazard.

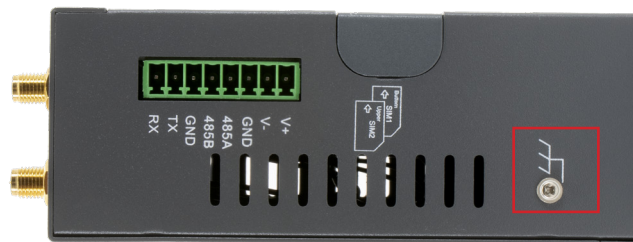

Figure 18. Earth Point



Reset

The QUARTZ-ONYX can be returned to default settings by pressing and holding down the recessed reset switch while the router is powered.

Two forms of reset are possible:

1. Custom reset where customer reset defaults are restored by pressing the recessed reset switch for at least 1 second, or
2. Factory reset by pressing the recessed reset switch for at least 60 seconds, or

Customer reset defaults are set up in the software interface. This is a useful mode of operation to return to known working settings rather than full factory reset if the configuration settings are being experimented with.

SIM Socket

The QUARTZ-ONYX will accept any data enabled SIM card. These may be Pay As You Go (PAYG) or Contract, fixed IP address or normal consumer SIM cards. However, it is recommended that a contract SIM card be used. These are normally shipped ready for use. PAYG SIM cards often need to be activated first in a normal phone before being used in a router.

The SIM card holder is designed to accept either one or two mini-SIM (2FF) (measuring 25 mm x 15 mm). The SIM card voltages supported are 1.8 V and 3.3 V, meaning that the interface will be compatible with any SIM card manufactured after 1998.

Use a 00 Philips screwdriver to remove the screw retaining the plate covering the dual SIM card socket to be able to insert one or two SIM cards. Only one SIM card is necessary for operation. A second SIM card may be used for failover or backup operation. If using one SIM card, either SIM socket may be used.



Figure 19. Remove SIM cover plate

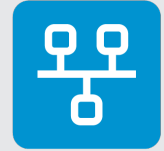

Figure 20. Dual SIM card holder



Figure 21. With one SIM fitted

Note that alignment mark on the SIM card should match the marking on the QUARTZ-ONYX. The SIM card should be inserted with the electrical contacts face down. Note which SIM card is inserted into the lower slot ('SIM 1') and which inserted into the upper slot ('SIM 2'). This information will be required when setting up the QUARTZ-ONYX.



Antenna Connectors

Cellular Antenna Connector

The QUARTZ-ONYX is designed for use with 50 Ohm SMA male antennas. Four cellular antennas are required to fully support all the operating bands and data transfer rates. Performance with fewer antennas cannot be easily predicted.

When selecting an antenna, chose an antenna with a frequency band support that matches the frequencies supported by the QUARTZ-ONYX and the chosen network operator. Note that different countries and different network operators support different frequency bands. If in any doubt, do a cellular site survey with one of Siretta's cellular network analysers to find which network operators are present and on which frequency bands they operate.

The selected antenna needs to conform to the following requirements:

Parameter	Value
VSWR	≤ 3
Efficiency	$> 30\%$
Input impedence	50 Ω
Cable insertion loss (< 1 GHz)	<1 dB
Cable insertion loss (< 1 – 2.3 GHz)	<1.5 dB
Cable insertion loss (> 2.3 GHz)	<2 dB

The antennas supplied as part of the accessory kit will meet these requirements. Connect the antennas to the inputs marked "5G-1, 5G-2, 5G-3 and 5G-4".



Figure 22. Cellular Antenna Connectors (GPS Version)



Figure 23. Cellular Antenna Connectors (non-GPS version)

The antennas should be placed at least 50 cm apart to prevent interference between them provide the best performance. Placing the antennas closer together may result in unnecessary packet re-transmission or even drop out on the cellular connection. Packet re-transmission will be due to transmission errors which not only reduce the effective bandwidth of the cellular connection but may also count against the data allowance provided by the cellular network provider.



GPS Antenna Connector

If the QUARTZ-ONYX has the GPS option, then a GPS antenna is required for this option to work. Use an active antenna with a 50 Ohm SMA male connector meeting the following requirements:

Parameter	Value
Impedance	50 Ω
Frequency range	1575.42 \pm 3 MHz
Polarization	RHCP
VSWR	\leq 2
Maximum noise	1.5 dB
Minimum gain	15 dB
Maximum gain	30 dB

The magnetic mount active GPS antenna supplied as part of the accessory kit meets these specifications. Connect it to the input marked 'GPS'.



Figure 24. GPS Antenna Connectors (GPS Version)

The maximum allowed load current of the antenna allowed is 25 mA. With 25 mA load, the supply voltage to the active antenna is 3.0 V and with no load 3.3 V. The output voltage scales linearly with the load.

The GPS antenna should be placed where it has the best possible view of the sky. The greater the view of the sky, the greater the number of satellites that the GPS receiver will be able to see. More satellites in view means faster time to first fix and greater position accuracy.

With unobstructed line of sight to the sky in all directions, 8-10 satellites should be visible. If placed against a building such that half of the visibility to the sky is obstructed, then 4-5 satellites would typically be seen. Four satellites are required to establish the position. Having established the position, it is possible to maintain the position measurement with only 3 satellites.

WiFi Antenna Connector

The WiFi requires two antennas with a 50 Ohm reverse polarity SMA connector meeting the following requirements:

Parameter	Value
VSWR	≤1.5
Minimum input power	1 W
Frequency range (2.4 GHz band)	2.4 to 2.5 GHz
Frequency range (5 GHz band)	5.15 to 5.85 GHz
Polarization	Vertical
Gain (2.4 GHz band)	3.0 dBi maximum*
Gain (5 GHz band)	3.0 dBi maximum*

*Note that connecting an antenna exceeding this gain will invalidate this routers compliance with EN 300328 and is not under any circumstances allowed. Siretta takes no responsibility should higher gain antennas be used with this router. The antennas supplied with the optional accessory kit have a gain of 3 dBi and a uniform radiation pattern in the XY plane.



Figure 25. WiFi Antenna Connectors (GPS Version)



Figure 26. WiFi Antenna Connectors (non-GPS version)

Power

Power is supplied via a green 8-way 3.50 mm pitch terminal block which also carries the RS232/RS485 connections. The mating connector for the terminal block is Phoenix Contact part number 1840421 or equivalent. All QUARTZ-ONYX models are supplied with an adapter cable consisting of the 8-way connector with power cable fitted (15 cm in length) and a socket so that a power supply with a 2.1 mm Barrel Plug (2.1 x 5.5) can be used to power the QUARTZ-ONYX. A QUARTZ-ONYX purchased with accessories will include a 12 V, 2 A power supply. If using an alternative power supply, this should at least 24 W of output power.



Figure 27. Terminal block to DC power jack adapter supplied with all models

The power connector is shared with that of the RS232/RS485 interface. Power should be connected to V+ and V-. The GND terminals are the ground reference for the RS232 connections and should not be used for the power supply connection.

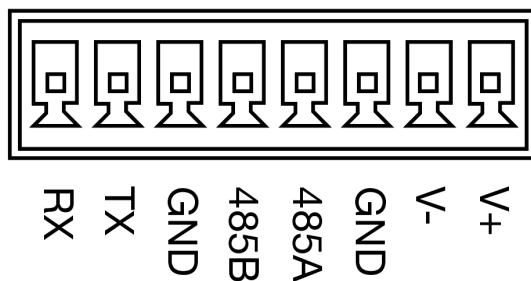

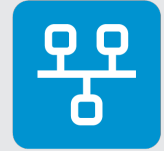

Copyright Information

Copyright Declarations

© 2022 Siretta Ltd, all rights reserved

No part of this publication may be reproduced, transmitted, transcribed, stored in a retrieval system, or translated into any language without the written permission of Siretta Ltd.

Trademarks

Windows and Microsoft are registered trademarks of Microsoft Corporation. Siretta Ltd is an independent business and is neither affiliated with, nor authorized, sponsored, or approved by, Microsoft Corporation.

Snapdragon is a registered trademark of Qualcomm in the United States and other countries.

Quectel is a registered trademark of Quectel Wireless Solutions Co. LTD in the United States and other countries.

Arm and Cortex are registered trademarks of Arm Limited (or its subsidiaries) in the United States and/or elsewhere.

MIPS is a registered trademark of MIPS and MIPS' affiliates as applicable in the United States and other countries.

All other trademarks are the property of their respective owners.



Approvals

- » **CE** - European Conformity
- » **UKCA** - UK Conformity Assessed
- » **RoHS** - Restriction of the Use of Certain Hazardous Substances Compliant
- » **FCC** - (TBC)

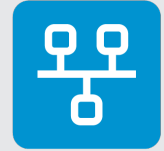

Disclaimer

The information contained in this document is proprietary to Siretta Ltd. Siretta Ltd has made every effort to ensure that the information contained within this document is accurate. Siretta Ltd does not make any warranty as to the information contained within this document and does not accept any liability for any injury, loss or damage of any kind incurred using this information.

Siretta does not take responsibility for any application developed using the product characterized in this document and notes that any application implemented with this product must comply with the safety standards of the applicable country and comply with the relevant wiring rules. Siretta reserves the right to make modifications, additions, and deletions to this document due to typographical errors, inaccurate information, or improvements to equipment at any time and without notice. Such changes will be incorporated into new editions of this document.

Please refer to the [Siretta Ltd](https://www.siretta.com) website for the latest version of this document.

© 2022 Siretta Ltd

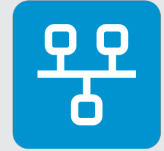

Definitions

Term	Definition
3G	3rd Generation Mobile Telecommunications
4G	4th Generation Mobile Telecommunications
5G	5th Generation Mobile Telecommunications
ADSL	Asymmetric Digital Subscriber Line
DC	Direct Current
DHCP	Dynamic Host Configuration Protocol
FDD	Frequency Division Duplex
GbE	Gigabit Ethernet
GPS	Global Positioning System
IP	Internet Protocol
LAN	Local Area Network
LED	Light Emitting Diode
LTE	Long-Term Evolution
MDI	Medium Dependent Interface
MIMO	Multiple-input and Multiple-output
RHCP	Right-handed Circular Polarization
RXD	Receive Data
SIM	Subscriber Identity Module
SMS	Short Message Service
TDD	Time Division Duplex
TXD	Transmit Data
UMTS	Universal Mobile Telecommunications System

VPN	Virtual Private Network
VSWR	Voltage Standing Wave Ratio
WAN	Wide Area Network
WLAN	Wireless Local Area Network

FCC Statement

This equipment has been tested and found to comply with the limits for a Class B digital device, pursuant to part 15 of the FCC Rules. These limits are designed to provide reasonable protection against harmful interference in a residential installation. This equipment generates, uses and can radiate radio frequency energy and, if not installed and used in accordance with the instructions, may cause harmful interference to radio communications. However, there is no guarantee that interference will not occur in a particular installation. If this equipment does cause harmful interference to radio or television reception, which can be determined by turning the equipment off and on, the user is encouraged to try to correct the interference by one or more of the following measures:

- Reorient or relocate the receiving antenna.
- Increase the separation between the equipment and receiver.
- Connect the equipment into an outlet on a circuit different from that to which the receiver is connected.
- Consult the dealer or an experienced radio/TV technician for help.

Caution: Any changes or modifications to this device not explicitly approved by manufacturer could void your authority to operate this equipment.

This device complies with part 15 of the FCC Rules. Operation is subject to the following two conditions: (1) This device may not cause harmful interference, and (2) this device must accept any interference received, including interference that may cause undesired operation.

RF Exposure Information

This equipment complies with FCC radiation exposure limits set forth for an uncontrolled environment. This equipment should be installed and operated with minimum distance 20cm between the radiator and your body.



Enabling Industrial IoT

sales +44 (0)118 976 9000

email sales@siretta.com

www.siretta.com

Siretta Ltd
Basingstoke Road
Spencers Wood
Reading
Berkshire
RG7 1PW
United Kingdom

Company No. 08405712
VAT Registration No. GB163 04 0349

