



### TEST REPORT FCC Part 27

Report Reference No.....: HK1910082514-13E

FCC ID.....: 2AVI7-91DA3C

Compiled by  
( position+printedname+signature)...: File administrators Gary Qian

Supervised by  
(position+printedname+signature)....: Technique principal Eden Hu

Approved by  
(position+printedname+signature)....: Manager Jason Zhou

Date of issue.....: Oct. 16, 2019

Testing Laboratory Name .....: Shenzhen HUAKE Testing Technology Co., Ltd.

Address .....: 1F, B2 Building, Junfeng Zhongcheng Zhizao Innovation Park,  
Heping Community, Fuhai Street, Bao' an District, Shenzhen,China

Applicant's name.....: Webee Corporation

Address .....: SUITE# W014. 440 N. Wolfe Road, Sunnyvale, CA 94085

Test specification .....

Standard.....: FCC CFR Title 47 Part 2, Part 27

TRF Originator.....: Shenzhen HUAKE Testing Technology Co., Ltd.

**Shenzhen HUAKE Testing Technology Co., Ltd.All rights reserved.**

This publication may be reproduced in whole or in part for non-commercial purposes as long as the Shenzhen HUAKE Testing Technology Co., Ltd.as copyright owner and source of the material. Shenzhen HUAKE Testing Technology Co., Ltd.takes no responsibility for and will not assume liability for damages resulting from the reader's interpretation of the reproduced material due to its placement and context.

Test item description .....: Smartee G3

Trade Mark .....: /

Manufacturer.....: Webee Corporation

Model/Type reference.....: SM3001

Listed Models .....: SM3001+, SM3001x, PCHQ1

Modulation Type.....: QPSK, 16QAM

Rating .....: DC5V/3A From Adapter

Hardware version .....: V1.2

Software version.....: V1.2

Result.....: **PASS**

**TEST REPORT**

<b>Test Report No. :</b>	<b>HK1910082514-13E</b>	Oct. 16, 2019
		Date of issue

Equipment under Test : Smartee G3

Model /Type : SM3001

Listed Models : SM3001+, SM3001x, PCHQ1

**Applicant** : Webee Corporation

Address : SUITE# W014. 440 N. Wolfe Road, Sunnyvale, CA 94085

**Manufacturer** : Webee Corporation

Address : SUITE# W014. 440 N. Wolfe Road, Sunnyvale, CA 94085

<b>Test Result:</b>	<b>PASS</b>
---------------------	-------------

The test report merely corresponds to the test sample.  
It is not permitted to copy extracts of these test result without the written permission of the test laboratory.



## Revision History

Revision	Issue Date	Revisions	Revised By
V1.0	2019-10-16	Initial Issue	James Zhou



## Contents

<b><u>1</u></b>	<b><u>TEST STANDARDS .....</u></b>	<b><u>5</u></b>
<b><u>2</u></b>	<b><u>SUMMARY .....</u></b>	<b><u>6</u></b>
2.1	General Remarks	6
2.2	Product Description	6
2.3	Equipment under Test	6
2.4	Short description of the Equipment under Test (EUT)	6
2.5	Normal Accessory setting	7
2.6	EUT configuration	7
2.7	Related Submittal(s) / Grant (s)	7
2.8	Modifications	7
2.9	General Test Conditions/Configurations	7
<b><u>3</u></b>	<b><u>TEST ENVIRONMENT .....</u></b>	<b><u>8</u></b>
3.1	Address of the test laboratory	8
3.2	Test Description	8
3.3	Equipments Used during the Test	9
<b><u>4</u></b>	<b><u>TEST CONDITIONS AND RESULTS .....</u></b>	<b><u>10</u></b>
4.1	Output Power	10
4.2	Peak-to-Average Ratio (PAR)	14
4.3	Occupied Bandwidth and Emission Bandwidth	15
4.4	Band Edge compliance	16
4.5	Spurious Emission on Antenna Port	17
4.6	Radiated Spurious Emission	18
4.7	Frequency Stability	24
<b><u>5</u></b>	<b><u>TEST SETUP PHOTOS OF THE EUT .....</u></b>	<b><u>26</u></b>
<b><u>6</u></b>	<b><u>EXTERNAL AND INTERNAL PHOTOS OF THE EUT .....</u></b>	<b><u>27</u></b>



# **1 TEST STANDARDS**

The tests were performed according to following standards:

[FCC Part 2](#): FREQUENCY ALLOCATIONS AND RADIO TREATY MATTERS; GENERAL RULES AND REGULATIONS

[FCC Part 27](#): MISCELLANEOUS WIRELESS COMMUNICATIONS SERVICES

[ANSI/TIA-603-E-2016](#): Land Mobile FM or PM Communications Equipment Measurement and Performance Standards.

[ANSI C63.26-2015](#): IEEE/ANSI Standard for Compliance Testing of Transmitters Used in Licensed Radio Services

[FCC KDB971168D01](#) Power Meas License Digital Systems



## 2 SUMMARY

### 2.1 General Remarks

Date of receipt of test sample	:	Oct. 09, 2019
Testing commenced on	:	Oct. 15, 2019
Testing concluded on	:	Oct. 16, 2019

### 2.2 Product Description

The **Webee Corporation's** Model: SM3001 or the "EUT" as referred to in this report; more general information as follows, for more details, refer to the user's manual of the EUT.

Name of EUT	Smartee G3
Model/Type reference:	SM3001
List Model:	SM3001+, SM3001x, PCHQ1
Power supply:	DC 5.0V
Adapter Information	DC5V/3A From Adapter
Modulation Type	QPSK, 16QAM
Antenna Type	Internal Antenna
Antenna Gain	1dBi
Operation Frequency Band	LTE Band 7
Operation frequency	LTE Band 7: 2500 to 2570 MHz
LTE Release	R8
Extreme temp. Tolerance	-30°C to +50°C
Extreme vol. Limits	N/A

### 2.3 Equipment under Test

#### Power supply system utilised

Power supply voltage	:	<input type="radio"/> 120V/ 60 Hz	<input type="radio"/> 115V/60Hz
		<input type="radio"/> 12 V DC	<input type="radio"/> 24 V DC
		<input checked="" type="radio"/> Other (specified in blank below)	

DC5V/3A From Adapter

### 2.4 Short description of the Equipment under Test (EUT)

#### 2.4.1 General Description

SM3001 is subscriber equipment in the LTE system. LTE frequency band is band 41; The Smartee G3 implements such functions as RF signal receiving/transmitting, LTE protocol processing, voice, video MMS service, etc. Externally it provides microSD card interface, earphone port (to provide voice service) and SIM card interface.



### 2.5 Normal Accessory setting

Fully charged battery was used during the test.

### 2.6 EUT configuration

The following peripheral devices and interface cables were connected during the measurement:

- supplied by the manufacturer
- supplied by the lab

<input type="radio"/>	Power Cable	Length (m) :	/
		Shield :	/
		Detachable :	/
<input type="radio"/>	Multimeter	Manufacturer :	/
		Model No. :	/

### 2.7 Related Submittal(s) / Grant (s)

This submittal(s) (test report) is intended for FCC ID: 2AVI7-91DA3C filing to comply with FCC Part 27, Rules.

### 2.8 Modifications

No modifications were implemented to meet testing criteria.

### 2.9 General Test Conditions/Configurations

#### 2.9.1 Test Environment

Environment Parameter	Selected Values During Tests	
Relative Humidity	Ambient	
Temperature	TN	Ambient
Voltage	VL	4.5V
	VN	5.0V
	VH	5.5V

NOTE: VL=lower extreme test voltage VN=nominal voltage  
VH=upper extreme test voltage TN=normal temperature



### **3 TEST ENVIRONMENT**

#### **3.1 Address of the test laboratory**

Test Firm : Shenzhen HUAKE Testing Technology Co., Ltd.

Address : 1F, B2 Building, Junfeng Zhongcheng Zhizao Innovation Park, Fuhai Street, Bao'an District, Shenzhen City, China

FCC designation number : CN1229

test firm registration number : 616276

#### **3.2 Test Description**

<b>Test Item</b>	<b>FCC Rule No.</b>	<b>Verdict</b>
Effective(Isotropic)RadiatedOutputPower	Part 2.1046 27.50(h)(2)	Pass
Peak-AverageRatio	Part 2.1046	compliance *
ModulationCharacteristics	§2.1047	compliance *
Bandwidth	Part 2.1049	compliance *
BandEdgesCompliance	Part 2.1051 27.53(m)	compliance *
SpuriousEmissionatAntennaTerminals	Part 2.1051 27.53(m)	compliance *
Field Strengthof Spurious Radiation	Part 2.1053 27.53(m)	Pass
Frequency Stability	Part 2.1055 27.54	compliance *

NOTE 1: For the verdict, the " compliance \*" Test data refers to FCC ID:XMR201903EG25G, and report number is:HR/2019/100160.

Remark:

1. The measurement uncertainty is not included in the test result.





### 3.3 Equipments Used during the Test

Test Equipment	Manufacturer	Model No.	Serial No.	Calibration Date	Calibration Due Date
LISN	R&S	ENV216	HKE-059	2018/12/27	2019/12/26
LISN	R&S	ENV216	HKE-002	2018/12/27	2019/12/26
Receiver	R&S	ESCI 7	HKE-010	2018/12/27	2019/12/26
Spectrum analyzer	R&S	FSP40	HKE-025	2018/12/27	2019/12/26
Spectrum analyzer	Agilent	N9020A	HKE-048	2018/12/27	2019/12/26
RF automatic control unit	Tonscend	JS0806-1	HKE-060	2018/12/27	2019/12/26
Loop antenna	Schwarzbeck	FMZB 1519 B	HKE-014	2018/12/27	2019/12/26
Bilog Broadband Antenna	Schwarzbeck	VULB9163	HKE-012	2018/12/27	2019/12/26
Horn antenna	Schwarzbeck	9120D	HKE-013	2018/12/27	2019/12/26
High gain antenna	Schwarzbeck	LB-180400KF	HKE-054	2018/12/27	2019/12/26
Preamplifier	EMCI	EMC051845SE	HKE-015	2018/12/27	2019/12/26
Preamplifier	Agilent	83051A	HKE-016	2018/12/27	2019/12/26
Preamplifier	Schwarzbeck	BBV 9743	HKE-006	2018/12/27	2019/12/26
Temperature and humidity meter	Boyang	HTC-1	HKE-075	2018/12/27	2019/12/26
High-low temperature chamber	Guangke	HT-80L	HKE-118	2018/12/27	2019/12/26
High pass filter unit	Tonscend	JS0806-F	HKE-055	2018/12/27	2019/12/26
RF Cable(below 1GHz)	Times	9kHz-1GHz	HKE-117	2018/12/27	2019/12/26
RF Cable(above 1GHz)	Times	1-40G	HKE-034	2018/12/27	2019/12/26
Power meter	Agilent	E4419B	HKE-085	2018/12/27	2019/12/26
Power Sensor	Agilent	E9300A	HKE-086	2018/12/27	2019/12/26
Conducted test software	Tonscend	TS+ Rev 2.5.0.0	HKE-081	N/A	N/A
Radiated test software	Tonscend	TS+ Rev 2.5.0.0	HKE-082	N/A	N/A
RF test software	Tonscend	JS1120-B Version 2.6	HKE-083	N/A	N/A
RF test software	Tonscend	JS1120-4	HKE-113	N/A	N/A
RF test software	Tonscend	JS1120-3	HKE-114	N/A	N/A
RF test software	Tonscend	JS1120-1	HKE-115	N/A	N/A
Wireless Communication Test Set	R&S	CMW500	HKE-026	2018/12/27	2019/12/26
Wireless Communication Test Set	R&S	CMU200	HKE-029	2018/12/27	2019/12/26
Horn Antenna	Schwarzbeck	BBHA 9170	HKE-017	2018/12/27	2019/12/26



## **4 TEST CONDITIONS AND RESULTS**

### **4.1 Output Power**

#### **4.1.1 Conducted Output Power**

##### **TEST APPLICABLE**

Part 27.50(h)(2), during the process of testing, the EUT was controlled via R&S Digital Radio Communication tester (CMW500) to ensure max power transmission and proper modulation. This result contains output power measurements for the EUT. In all cases, output power is within the specified limits.

##### **TEST CONFIGURATION**

Conducted Power Measurement:

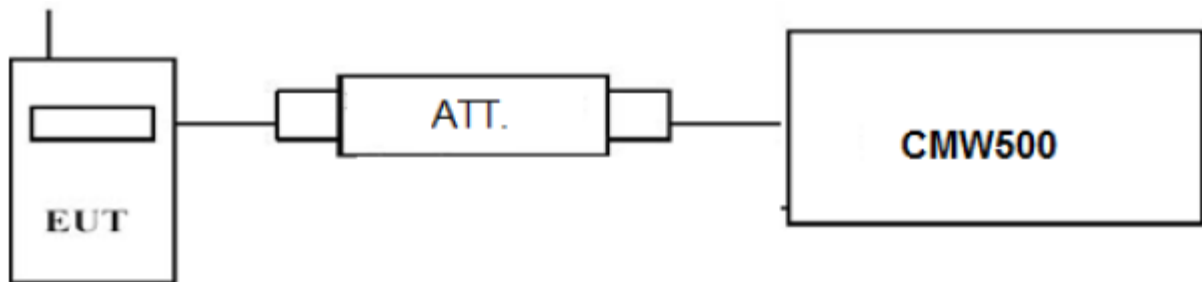

##### **TEST PROCEDURE**

###### **Conducted Power Measurement:**

- a) Place the EUT on a bench and set it in transmitting mode.
- b) Connect a low loss RF cable from the antenna port to a CMW500 by an Att.
- c) EUT Communicate with CMW500 then selects a channel for testing.
- d) Add a correction factor to the display CMW500, and then test.

##### **TEST RESULTS**

**N/A\***

Note: Test data refers to FCC ID: XMR201903EG25G, and report number is: HR/2019/100160.

## 4.1.2. Radiated Output Power

### LIMIT

This is the test for the maximum radiated power from the EUT.

### TEST CONFIGURATION

Radiated Power Measurement:

remark : 0.8m for below 1GHz, 1.5m for above 1GHz

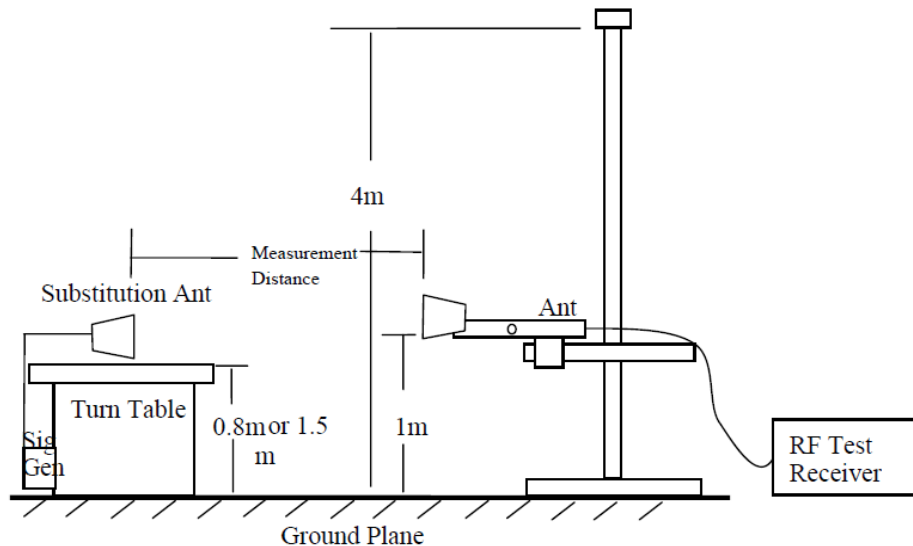

### TEST PROCEDURE

The EUT was setup according to EIA/TIA 603D

- a. The EUT shall be placed at the specified height on a support, and in the position closest to normal use as declared by provider.
- b. The test antenna shall be oriented initially for vertical polarization and shall be chosen to correspond to the frequency of the transmitter.
- c. The output of the test antenna shall be connected to the measuring receiver.
- d. The transmitter shall be switched on and the measuring receiver shall be tuned to the frequency of the transmitter under test.
- e. The test antenna shall be raised and lowered through the specified range of height until a maximum signal level is detected by the measuring receiver.
- f. The transmitter shall then be rotated through 360° in the horizontal plane, until the maximum signal level is detected by the measuring receiver.
- g. The test antenna shall be raised and lowered again through the specified range of height until a maximum signal level is detected by the measuring receiver.
- h. The maximum signal level detected by the measuring receiver shall be noted.
- i. The transmitter shall be replaced by a substitution antenna.
- j. The substitution antenna shall be orientated for vertical polarization and the length of the substitution antenna shall be adjusted to correspond to the frequency of the transmitter.
- k. The substitution antenna shall be connected to a calibrated signal generator.
- l. If necessary, the input attenuator setting of the measuring receiver shall be adjusted in order to increase the sensitivity of the measuring receiver.
- m. The test antenna shall be raised and lowered through the specified range of height to ensure that the maximum signal is received.
- n. The input signal to the substitution antenna shall be adjusted to the level that produces a level detected by the measuring receiver, that is equal to the level noted while the transmitter radiated power was measured, corrected for the change of input attenuator setting of the measuring receiver.
- o. The measurement shall be repeated with the test antenna and the substitution antenna orientated for horizontal polarization.
- p. The measure of the effective radiated power is the larger of the two levels recorded at the input to the substitution antenna, corrected for gain of the substitution antenna if necessary.
- q. Test site anechoic chamber refer to ANSI C63.4.

**TEST RESULTS**

EUT :	Smartee G3	Test Date:	July 11, 2019
Temperature:	25°C	Tested by:	Gary Qian
Humidity:	55 % RH	Test Voltage	Normal Voltage
Operation Mode:	Normal Voltage- Tx Mode		

**Radiated Measurement:**

Remark:

1. We measured all RB Configuration refer 3GPP TS136 521 for each Channel Bandwidth of LTE Band 7; recorded worst case for each Channel Bandwidth of LTE Band 7.
2.  $EIRP = P_s(\text{dBm}) - P_{cl}(\text{dB}) + G_a(\text{dBi})$
3. We measured both Horizontal and Vertical direction, recorded worst case direction.

**LTE Band 7\_Channel Bandwidth 5MHz\_QPSK\_1RB#0**

Frequency (MHz)	$P_s$ (dBm)	$P_{cl}$ (dB)	$G_a$ Antenna Gain(dB)	Burst Average EIRP (dBm)	Limit (dBm)	Margin (dB)	Polarization
2502.5	7.61	3.41	15.12	19.32	33.01	13.69	V
2535	8.08	3.49	15.12	19.71	33.01	13.3	V
2567.5	7.63	3.55	15.12	19.2	33.01	13.81	V
2502.5	7.14	3.41	15.12	18.85	33.01	14.16	H
2535	7.73	3.49	15.12	19.36	33.01	13.65	H
2567.5	7.45	3.55	15.12	19.02	33.01	13.99	H

**LTE Band 7\_Channel Bandwidth 10MHz\_QPSK\_1RB#0**

Frequency (MHz)	$P_s$ (dBm)	$P_{cl}$ (dB)	$G_a$ Antenna Gain(dB)	Burst Average EIRP (dBm)	Limit (dBm)	Margin (dB)	Polarization
2505	7.29	3.41	15.12	19	33.01	14.01	V
2535	7.75	3.49	15.12	19.38	33.01	13.63	V
2565	7.12	3.55	15.12	18.69	33.01	14.32	V
2505	7.5	3.41	15.12	19.21	33.01	13.8	H
2535	8.05	3.49	15.12	19.68	33.01	13.33	H
2565	6.94	3.55	15.12	18.51	33.01	14.5	H

**LTE Band 7\_Channel Bandwidth 15MHz\_QPSK\_1RB#0**

Frequency (MHz)	$P_s$ (dBm)	$P_{cl}$ (dB)	$G_a$ Antenna Gain(dB)	Burst Average EIRP (dBm)	Limit (dBm)	Margin (dB)	Polarization
2507.5	7.04	3.41	15.12	18.75	33.01	14.26	V
2535	8.1	3.49	15.12	19.73	33.01	13.28	V
2507.5	6.8	3.55	15.12	18.37	33.01	14.64	V
2507.5	6.75	3.41	15.12	18.46	33.01	14.55	H
2535	7.67	3.49	15.12	19.3	33.01	13.71	H
2507.5	7.08	3.55	15.12	18.65	33.01	14.36	H

**LTE Band 7\_Channel Bandwidth 20MHz\_QPSK\_1RB#0**

Frequency (MHz)	$P_s$ (dBm)	$P_{cl}$ (dB)	$G_a$ Antenna Gain(dB)	Burst Average EIRP (dBm)	Limit (dBm)	Margin (dB)	Polarization
2510	7.74	3.41	15.12	19.45	33.01	13.56	V
2535	7.55	3.49	15.12	19.18	33.01	13.83	V
2560	7.04	3.55	15.12	18.61	33.01	14.4	V
2510	7.85	3.41	15.12	19.56	33.01	13.45	H
2535	8.23	3.49	15.12	19.86	33.01	13.15	H
2560	6.99	3.55	15.12	18.56	33.01	14.45	H



*LTE Band 7\_Channel Bandwidth 5MHz\_16QAM\_1RB#0*

Frequency (MHz)	P <sub>s</sub> (dBm)	P <sub>cl</sub> (dB)	G <sub>a</sub> Antenna Gain(dB)	Burst Average EIRP (dBm)	Limit (dBm)	Margin (dB)	Polarization
2502.5	7.88	3.41	15.12	19.59	33.01	13.42	V
2535	7.98	3.49	15.12	19.61	33.01	13.4	V
2567.5	6.85	3.55	15.12	18.42	33.01	14.59	V
2502.5	8.27	3.41	15.12	19.98	33.01	13.03	H
2535	8.02	3.49	15.12	19.65	33.01	13.36	H
2567.5	6.84	3.55	15.12	18.41	33.01	14.6	H

*LTE Band 7\_Channel Bandwidth 10MHz\_16QAM\_1RB#0*

Frequency (MHz)	P <sub>s</sub> (dBm)	P <sub>cl</sub> (dB)	G <sub>a</sub> Antenna Gain(dB)	Burst Average EIRP (dBm)	Limit (dBm)	Margin (dB)	Polarization
2505	7.03	3.41	15.12	18.74	33.01	14.27	V
2535	7.94	3.49	15.12	19.57	33.01	13.44	V
2565	6.8	3.55	15.12	18.37	33.01	14.64	V
2505	6.65	3.41	15.12	18.36	33.01	14.65	H
2535	7.56	3.49	15.12	19.19	33.01	13.82	H
2565	7.29	3.55	15.12	18.86	33.01	14.15	H

*LTE Band 7\_Channel Bandwidth 15MHz\_16QAM\_1RB#0*

Frequency (MHz)	P <sub>s</sub> (dBm)	P <sub>cl</sub> (dB)	G <sub>a</sub> Antenna Gain(dB)	Burst Average EIRP (dBm)	Limit (dBm)	Margin (dB)	Polarization
2507.5	7.49	3.41	15.12	19.2	33.01	13.81	V
2535	7.56	3.49	15.12	19.19	33.01	13.82	V
2507.5	7.25	3.55	15.12	18.82	33.01	14.19	V
2507.5	7.45	3.41	15.12	19.16	33.01	13.85	H
2535	7.25	3.49	15.12	18.88	33.01	14.13	H
2507.5	6.75	3.55	15.12	18.32	33.01	14.69	H

*LTE Band 7\_Channel Bandwidth 20MHz\_16QAM\_1RB#0*

Frequency (MHz)	P <sub>s</sub> (dBm)	P <sub>cl</sub> (dB)	G <sub>a</sub> Antenna Gain(dB)	Burst Average EIRP (dBm)	Limit (dBm)	Margin (dB)	Polarization
2510	8.27	3.41	15.12	19.98	33.01	13.03	V
2535	7.88	3.49	15.12	19.51	33.01	13.5	V
2560	6.78	3.55	15.12	18.35	33.01	14.66	V
2510	7.73	3.41	15.12	19.44	33.01	13.57	H
2535	7.49	3.49	15.12	19.12	33.01	13.89	H
2560	6.6	3.55	15.12	18.17	33.01	14.84	H



## 4.2 Peak-to-Average Ratio (PAR)

### LIMIT

The Peak-to-Average Ratio (PAR) of the transmission may not exceed 13 dB.

### TEST CONFIGURATION

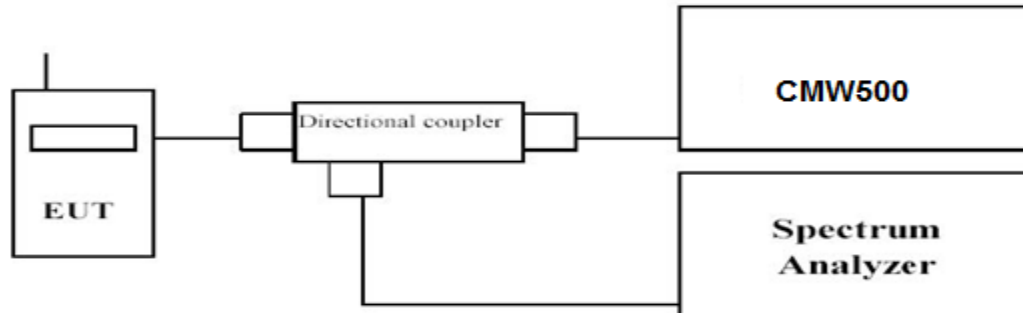

### TEST PROCEDURE

1. Refer to instrument's analyzer instruction manual for details on how to use the power statistics/CCDF function;
2. Set resolution/measurement bandwidth  $\geq$  signal's occupied bandwidth;
3. Set the number of counts to a value that stabilizes the measured CCDF curve;
4. Set the measurement interval as follows:
  - 1). for continuous transmissions, set to 1 ms,
  - 2). for burst transmissions, employ an external trigger that is synchronized with the EUT burst timing sequence, or use the internal burst trigger with a trigger level that allows the burst to stabilize and set the measurement interval to a time that is less than or equal to the burst duration.
5. Record the maximum PAPR level associated with a probability of 0.1%.

### TEST RESULTS

N/A\*

Note: Test data refers to FCC ID: XMR201903EG25G, and report number is: HR/2019/100160.



### 4.3 Occupied Bandwidth and Emission Bandwidth

#### LIMIT

N/A

#### TEST CONFIGURATION

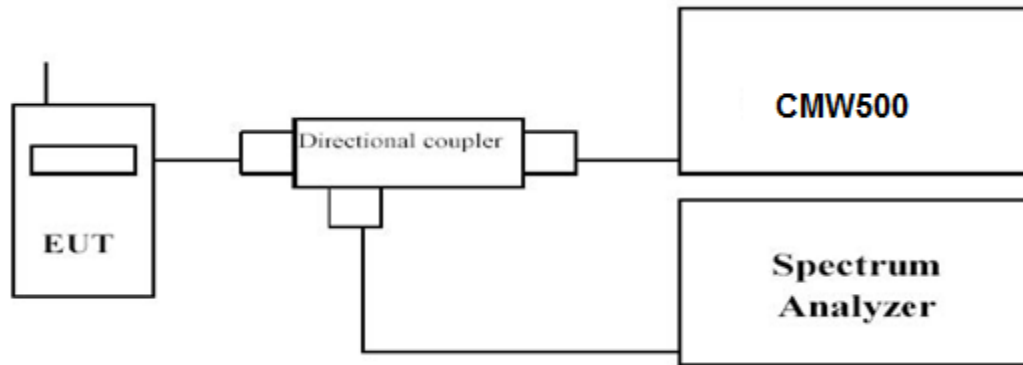

#### TEST PROCEDURE

The transmitter output was connected to a calibrated coaxial cable and coupler, the other end of which was connected to a spectrum analyzer. The occupied bandwidth was measured with the spectrum analyzer at low, middle and high channel in each band. The -26dBc Emission bandwidth was also measured and recorded. Set RBW was set to about 1% of emission BW, VBW  $\geq$  3 times RBW.

-26dBc display line was placed on the screen (or 99% bandwidth), the occupied bandwidth is the delta frequency between the two points where the display line intersects the signal trace.

#### TEST RESULTS

N/A\*

Note: Test data refers to FCC ID: XMR201903EG25G, and report number is: HR/2019/100160



## 4.4 Band Edge compliance

### LIMIT

the power of any emission outside of the authorized operating frequency ranges must be attenuated below the transmitting power (P) by a factor of at least  $40 + 10 \log P$  dB ( $-10$  dBm, 100 nW) on all frequencies between the channel edge and 5 MHz from the channel edge,  $43 + 10 \log P$  dB ( $-13$  dBm, 50 nW) on all frequencies between 5 MHz and X MHz from the channel edge, and  $55 + 10 \log P$  dB ( $-25$  dBm, 3 nW) on all frequencies more than 20 MHz from the channel edge, where X MHz is the greater of 6 MHz or the actual emission bandwidth (26 dB).

### TEST CONFIGURATION

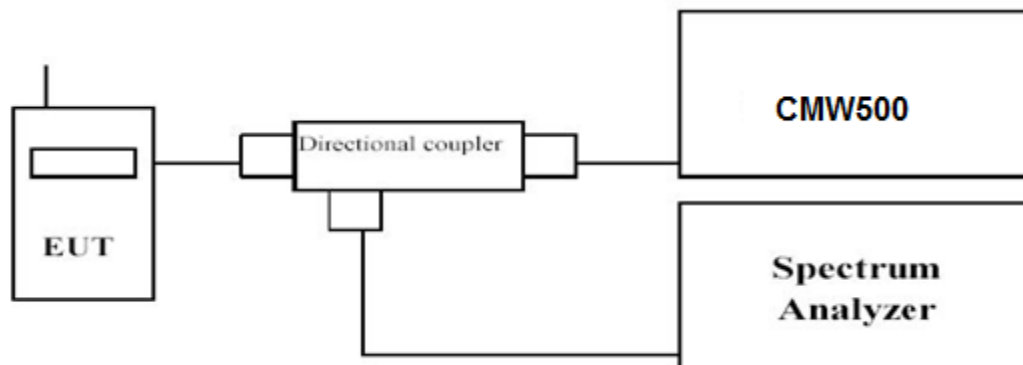

### TEST PROCEDURE

1. The transmitter output port was connected to base station.
2. The RF output of EUT was connected to the power meter by RF cable and attenuator, the path loss was compensated to the results for each measurement.
3. Set EUT at maximum power through base station.
4. Select lowest and highest channels for each band and different modulation.
5. Measure Band edge using RMS (Average) detector by spectrum
6. Set RBW = 100 kHz, VBW=300 kHz, Span=50MHz Peak Detector.

### TEST RESULTS

N/A\*

Note: Test data refers to FCC ID: XMR201903EG25G, and report number is: HR/2019/100160





### 4.5 Spurious Emission on Antenna Port

#### LIMIT

The power of any emission outside of the authorized operating frequency ranges must be attenuated below the transmitting power (P) by a factor of at least  $40 + 10 \log P$  dB (-10 dBm, 100 nW) on all frequencies between the channel edge and 5 MHz from the channel edge,  $43 + 10 \log P$  dB (-13 dBm, 50 nW) on all frequencies between 5 MHz and X MHz from the channel edge, and  $55 + 10 \log P$  dB (-25 dBm, 3 nW) on all frequencies more than 20 MHz from the channel edge, where X MHz is the greater of 6 MHz or the actual emission bandwidth (26 dB).

#### TEST CONFIGURATION

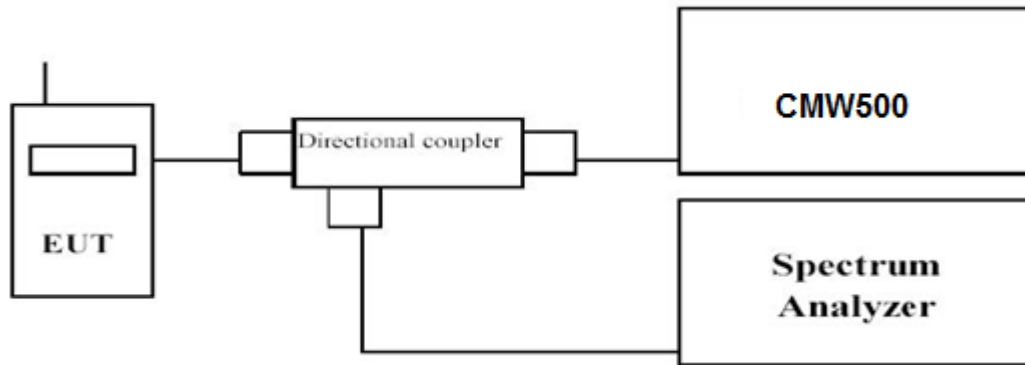

#### TEST PROCEDURE

The EUT was setup according to EIA/TIA 603D

- Place the EUT on a bench and set it in transmitting mode.
- Connect a low loss RF cable from the antenna port to a spectrum analyzer and CMW500 by a Directional Coupler.
- EUT Communicate with CMW500, then select a channel for testing.
- Add a correction factor to the display of spectrum, and then test.
- The resolution bandwidth of the spectrum analyzer was set sufficient scans were taken to show the out of band Emission if any up to 10<sup>th</sup> harmonic.
- Please refer to following tables for test antenna conducted emissions.

Working Frequency	Sub range (GHz)	RBW	VBW	Sweep time (s)
LTE Band 7	0.03~26.5	1 MHz	3 MHz	Auto

#### TEST RESULTS

N/A\*

Note: Test data refers to FCC ID: XMR201903EG25G, and report number is: HR/2019/100160.

## 4.6 Radiated Spurious Emission

### TEST APPLICABLE

The power of any emission outside of the authorized operating frequency ranges must be attenuated below the transmitting power (P) by a factor of at least  $40 + 10 \log P$  dB ( $-10$  dBm, 100 nW) on all frequencies between the channel edge and 5 MHz from the channel edge,  $43 + 10 \log P$  dB ( $-13$  dBm, 50 nW) on all frequencies between 5 MHz and X MHz from the channel edge, and  $55 + 10 \log P$  dB ( $-25$  dBm, 3 nW) on all frequencies more than 20 MHz from the channel edge, where X MHz is the greater of 6 MHz or the actual emission bandwidth (26 dB).

### TEST CONFIGURATION

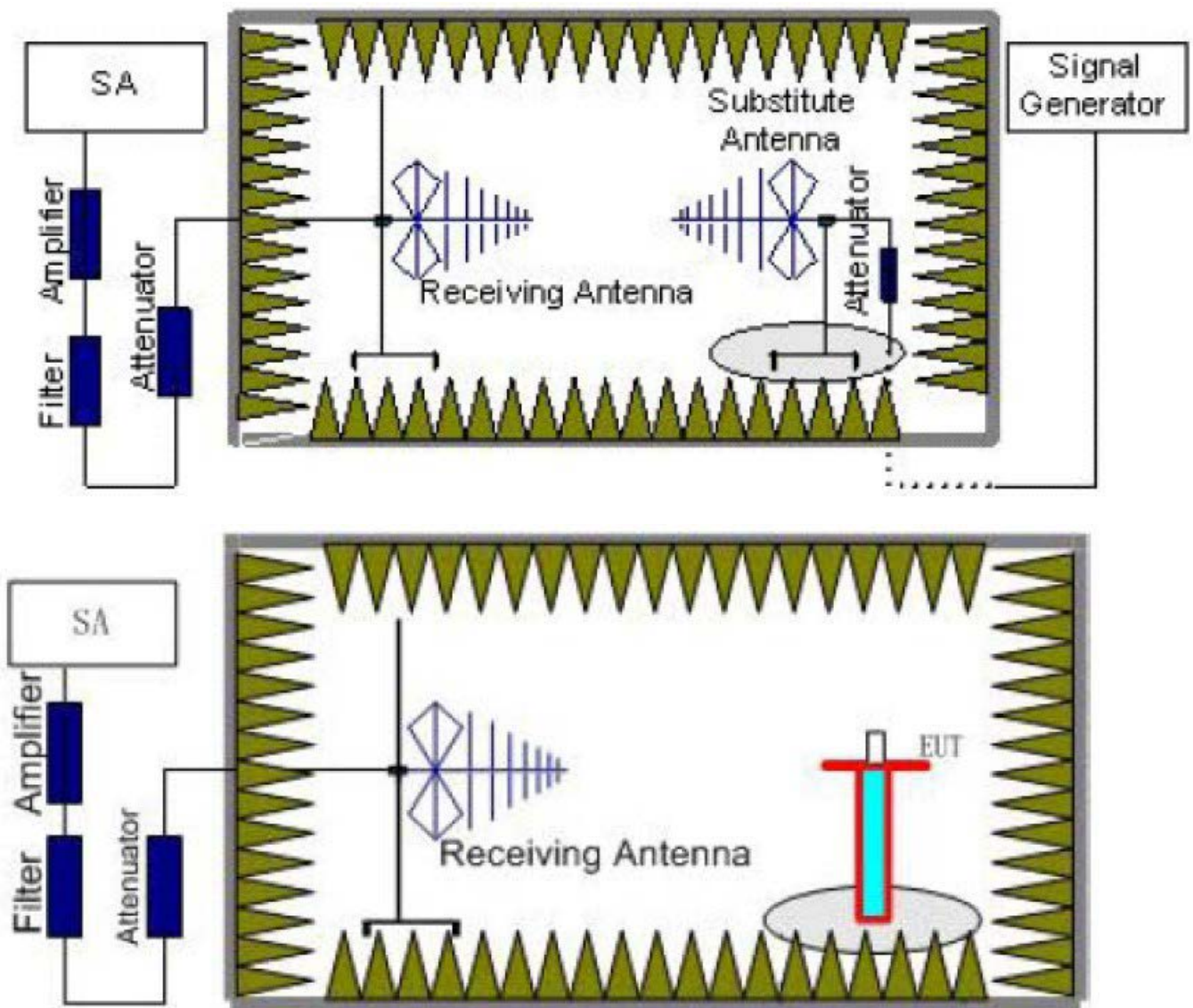

### TEST PROCEDURE

The EUT was setup according to EIA/TIA 603D

- The EUT shall be placed at the specified height on a support, and in the position closest to normal use as declared by provider.
- The test antenna shall be oriented initially for vertical polarization and shall be chosen to correspond to the frequency of the transmitter
- The output of the test antenna shall be connected to the measuring receiver.
- The transmitter shall be switched on and the measuring receiver shall be tuned to the frequency of the transmitter under test.



- e. The test antenna shall be raised and lowered through the specified range of height until a maximum signal level is detected by the measuring receiver.
- f. The transmitter shall then be rotated through 360° in the horizontal plane, until the maximum signal level is detected by the measuring receiver.
- g. The test antenna shall be raised and lowered again through the specified range of height until a maximum signal level is detected by the measuring receiver.
- h. The maximum signal level detected by the measuring receiver shall be noted.
- i. The transmitter shall be replaced by a substitution antenna.
- j. The substitution antenna shall be orientated for vertical polarization and the length of the substitution antenna shall be adjusted to correspond to the frequency of the transmitter.
- k. The substitution antenna shall be connected to a calibrated signal generator.
- l. If necessary, the input attenuator setting of the measuring receiver shall be adjusted in order to increase the sensitivity of the measuring receiver.
- m. The test antenna shall be raised and lowered through the specified range of height to ensure that the maximum signal is received.
- n. The input signal to the substitution antenna shall be adjusted to the level that produces a level detected by the measuring receiver, that is equal to the level noted while the transmitter radiated power was measured, corrected for the change of input attenuator setting of the measuring receiver.
- o. The measurement shall be repeated with the test antenna and the substitution antenna orientated for horizontal polarization.
- p. The measure of the effective radiated power is the larger of the two levels recorded at the input to the substitution antenna, corrected for gain of the substitution antenna if necessary.
- q. Test site anechoic chamber refer to ANSI C63.4:2014.

Frequency	Channel	Frequency Range	Verdict
LTE Band 7	Low	30MHz -26.5GHz	PASS
	Middle	30MHz -26.5GHz	PASS
	High	30MHz -26.5GHz	PASS

**Radiated Measurement:**

EUT :	Smartee G3	Test Date:	July 11, 2019
Temperature:	25°C	Tested by:	Gary Qian
Humidity:	55 % RH	Test Voltage	Normal Voltage
Operation Mode:	Normal Voltage- Tx Mode		

*Remark:*

1. We measured all RB Configuration refer 3GPP TS136 521 for each Channel Bandwidth of LTE Band 7; recorded worst case for each Channel Bandwidth of LTE Band 7.
2.  $EIRP = P_S(dBm) - P_{cl}(dB) + G_a(dBi)$
3. Not recorded other points means the reading of emissions are attenuated more than 20dB below the permissible limits or the field strength is too small to be measured.
4.  $Margin = Limit - EIRP$

LTE Band 7\_Channel Bandwidth 5MHz\_QPSK\_1RB#0\_Low Channel

Frequency (MHz)	P <sub>S</sub> (dBm)	P <sub>cl</sub> (dB)	Distance	G <sub>a</sub> Antenna Gain (dB)	Peak EIRP (dBm)	Limit (dBm)	Margin (dB)	Polarization
5005	-42.04	4.39	3.00	12.34	-34.09	-25.00	9.09	H
7507.5	-51.31	5.31	3.00	13.52	-43.1	-25.00	18.1	H
5005	-43.46	4.39	3.00	12.34	-35.51	-25.00	10.51	V
7507.5	-53.74	5.31	3.00	13.52	-45.53	-25.00	20.53	V

*LTE Band 7\_Channel Bandwidth 5MHz\_QPSK\_1RB#0\_Middle Channel*

Frequency (MHz)	P <sub>s</sub> (dBm)	P <sub>cl</sub> (dB)	Diatance	G <sub>a</sub> Antenna Gain(dB)	Peak EIRP (dBm)	Limit (dBm)	Margin (dB)	Polarization
5070	-41.9	4.41	3.00	12.34	-33.97	-25.00	8.97	H
7605	-49.49	5.38	3.00	13.58	-41.29	-25.00	16.29	H
5070	-44.25	4.41	3.00	12.34	-36.32	-25.00	11.32	V
7605	-51.66	5.38	3.00	13.58	-43.46	-25.00	18.46	V

*LTE Band 7\_Channel Bandwidth 5MHz\_QPSK\_1RB#0\_High Channel*

Frequency (MHz)	P <sub>s</sub> (dBm)	P <sub>cl</sub> (dB)	Diatance	G <sub>a</sub> Antenna Gain(dB)	Peak EIRP (dBm)	Limit (dBm)	Margin (dB)	Polarization
5135	-45.33	4.45	3.00	12.45	-37.33	-25.00	12.33	H
7702.5	-49.07	5.47	3.00	13.66	-40.88	-25.00	15.88	H
5135	-42.98	4.45	3.00	12.45	-34.98	-25.00	9.98	V
7702.5	-52.25	5.48	3.00	13.66	-44.07	-25.00	19.07	V

*LTE Band 7\_Channel Bandwidth 10MHz\_QPSK\_1RB#0\_Low Channel*

Frequency (MHz)	P <sub>s</sub> (dBm)	P <sub>cl</sub> (dB)	Diatance	G <sub>a</sub> Antenna Gain(dB)	Peak EIRP (dBm)	Limit (dBm)	Margin (dB)	Polarization
5010	-42.04	4.39	3.00	12.34	-34.09	-25.00	9.09	H
7515	-51.12	5.31	3.00	13.52	-42.91	-25.00	17.91	H
5010	-43.78	4.39	3.00	12.34	-35.83	-25.00	10.83	V
7515	-54.2	5.31	3.00	13.52	-45.99	-25.00	20.99	V

*LTE Band 7\_Channel Bandwidth 10MHz\_QPSK\_1RB#0\_Middle Channel*

Frequency (MHz)	P <sub>s</sub> (dBm)	P <sub>cl</sub> (dB)	Diatance	G <sub>a</sub> Antenna Gain(dB)	Peak EIRP (dBm)	Limit (dBm)	Margin (dB)	Polarization
5070	-41.98	4.41	3.00	12.34	-34.05	-25.00	9.05	H
7605	-50.04	5.38	3.00	13.58	-41.84	-25.00	16.84	H
5070	-44.31	4.41	3.00	12.34	-36.38	-25.00	11.38	V
7605	-51.63	5.38	3.00	13.58	-43.43	-25.00	18.43	V

*LTE Band 7\_Channel Bandwidth 10MHz\_QPSK\_1RB#0\_High Channel*

Frequency (MHz)	P <sub>s</sub> (dBm)	P <sub>cl</sub> (dB)	Diatance	G <sub>a</sub> Antenna Gain(dB)	Peak EIRP (dBm)	Limit (dBm)	Margin (dB)	Polarization
5130	-46.05	4.45	3.00	12.45	-38.05	-25.00	13.05	H
7695	-49.65	5.47	3.00	13.66	-41.46	-25.00	16.46	H
5130	-43.6	4.45	3.00	12.45	-35.6	-25.00	10.6	V
7695	-52.52	5.48	3.00	13.66	-44.34	-25.00	19.34	V

*LTE Band 7\_Channel Bandwidth 15MHz\_QPSK\_1RB#0\_Low Channel*

Frequency (MHz)	P <sub>s</sub> (dBm)	P <sub>cl</sub> (dB)	Diatance	G <sub>a</sub> Antenna Gain(dB)	Peak EIRP (dBm)	Limit (dBm)	Margin (dB)	Polarization
5015	-42	4.39	3.00	12.34	-34.05	-25.00	9.05	H
7522.5	-51.57	5.31	3.00	13.52	-43.36	-25.00	18.36	H
5015	-43.67	4.39	3.00	12.34	-35.72	-25.00	10.72	V
7522.5	-53.87	5.31	3.00	13.52	-45.66	-25.00	20.66	V

*LTE Band 7\_Channel Bandwidth 15MHz\_QPSK\_1RB#0\_Middle Channel*

Frequency (MHz)	P <sub>s</sub> (dBm)	P <sub>cl</sub> (dB)	Diatance	G <sub>a</sub> Antenna Gain(dB)	Peak EIRP (dBm)	Limit (dBm)	Margin (dB)	Polarization
5070	-42.05	4.41	3.00	12.34	-34.12	-25.00	9.12	H
7605	-49.58	5.38	3.00	13.58	-41.38	-25.00	16.38	H
5070	-44.8	4.41	3.00	12.34	-36.87	-25.00	11.87	V
7605	-51.95	5.38	3.00	13.58	-43.75	-25.00	18.75	V

*LTE Band 7\_Channel Bandwidth 15MHz\_QPSK\_1RB#0\_High Channel*

Frequency (MHz)	Ps (dBm)	P <sub>cl</sub> (dB)	Diatance	G <sub>a</sub> Antenna Gain(dB)	Peak EIRP (dBm)	Limit (dBm)	Margin (dB)	Polarization
5015	-45.24	4.45	3.00	12.45	-37.24	-25.00	12.24	H
7522.5	-49.67	5.47	3.00	13.66	-41.48	-25.00	16.48	H
5015	-43.66	4.45	3.00	12.45	-35.66	-25.00	10.66	V
7522.5	-51.76	5.48	3.00	13.66	-43.58	-25.00	18.58	V

*LTE Band 7\_Channel Bandwidth 20MHz\_QPSK\_1RB#0\_Low Channel*

Frequency (MHz)	Ps (dBm)	P <sub>cl</sub> (dB)	Diatance	G <sub>a</sub> Antenna Gain(dB)	Peak EIRP (dBm)	Limit (dBm)	Margin (dB)	Polarization
5020	-41.78	4.39	3.00	12.34	-33.83	-25.00	8.83	H
7530	-51.87	5.31	3.00	13.52	-43.66	-25.00	18.66	H
5020	-43.32	4.39	3.00	12.34	-35.37	-25.00	10.37	V
7530	-54.11	5.31	3.00	13.52	-45.9	-25.00	20.9	V

*LTE Band 7\_Channel Bandwidth 20MHz\_QPSK\_1RB#0\_Middle Channel*

Frequency (MHz)	Ps (dBm)	P <sub>cl</sub> (dB)	Diatance	G <sub>a</sub> Antenna Gain(dB)	Peak EIRP (dBm)	Limit (dBm)	Margin (dB)	Polarization
5070	-42.49	4.41	3.00	12.34	-34.56	-25.00	9.56	H
7605	-49.37	5.38	3.00	13.58	-41.17	-25.00	16.17	H
5070	-44.46	4.41	3.00	12.34	-36.53	-25.00	11.53	V
7605	-51.8	5.38	3.00	13.58	-43.6	-25.00	18.6	V

*LTE Band 7\_Channel Bandwidth 20MHz\_QPSK\_1RB#0\_High Channel*

Frequency (MHz)	Ps (dBm)	P <sub>cl</sub> (dB)	Diatance	G <sub>a</sub> Antenna Gain(dB)	Peak EIRP (dBm)	Limit (dBm)	Margin (dB)	Polarization
5120	-45.35	4.45	3.00	12.45	-37.35	-25.00	12.35	H
7680	-49.93	5.47	3.00	13.66	-41.74	-25.00	16.74	H
5120	-43.78	4.45	3.00	12.45	-35.78	-25.00	10.78	V
7680	-52.58	5.48	3.00	13.66	-44.4	-25.00	19.4	V

*LTE Band 7\_Channel Bandwidth 5MHz\_16QAM\_1RB#0\_Low Channel*

Frequency (MHz)	Ps (dBm)	P <sub>cl</sub> (dB)	Diatance	G <sub>a</sub> Antenna Gain(dB)	Peak EIRP (dBm)	Limit (dBm)	Margin (dB)	Polarization
5005	-41.54	4.39	3.00	12.34	-33.59	-25.00	8.59	H
7507.5	-51.75	5.31	3.00	13.52	-43.54	-25.00	18.54	H
5005	-43.39	4.39	3.00	12.34	-35.44	-25.00	10.44	V
7507.5	-54.37	5.31	3.00	13.52	-46.16	-25.00	21.16	V

*LTE Band 7\_Channel Bandwidth 5MHz\_16QAM\_1RB#0\_Middle Channel*

Frequency (MHz)	Ps (dBm)	P <sub>cl</sub> (dB)	Diatance	G <sub>a</sub> Antenna Gain(dB)	Peak EIRP (dBm)	Limit (dBm)	Margin (dB)	Polarization
5070	-41.97	4.41	3.00	12.34	-34.04	-25.00	9.04	H
7605	-49.33	5.38	3.00	13.58	-41.13	-25.00	16.13	H
5070	-44.71	4.41	3.00	12.34	-36.78	-25.00	11.78	V
7605	-51.82	5.38	3.00	13.58	-43.62	-25.00	18.62	V

*LTE Band 7\_Channel Bandwidth 5MHz\_16QAM\_1RB#0\_High Channel*

Frequency (MHz)	Ps (dBm)	P <sub>cl</sub> (dB)	Diatance	G <sub>a</sub> Antenna Gain(dB)	Peak EIRP (dBm)	Limit (dBm)	Margin (dB)	Polarization
5135	-45.45	4.45	3.00	12.45	-37.45	-25.00	12.45	H
7702.5	-49.16	5.47	3.00	13.66	-40.97	-25.00	15.97	H
5135	-43.39	4.45	3.00	12.45	-35.39	-25.00	10.39	V
7702.5	-52.05	5.48	3.00	13.66	-43.87	-25.00	18.87	V

*LTE Band 7\_Channel Bandwidth 10MHz\_16QAM\_1RB#0\_Low Channel*

Frequency (MHz)	Ps (dBm)	P <sub>cl</sub> (dB)	Diatance	G <sub>a</sub> Antenna Gain(dB)	Peak EIRP (dBm)	Limit (dBm)	Margin (dB)	Polarization
5010	-42.13	4.39	3.00	12.34	-34.18	-25.00	9.18	H
7515	-50.98	5.31	3.00	13.52	-42.77	-25.00	17.77	H
5010	-43.41	4.39	3.00	12.34	-35.46	-25.00	10.46	V
7515	-54.27	5.31	3.00	13.52	-46.06	-25.00	21.06	V

*LTE Band 7\_Channel Bandwidth 10MHz\_16QAM\_1RB#0\_Middle Channel*

Frequency (MHz)	Ps (dBm)	P <sub>cl</sub> (dB)	Diatance	G <sub>a</sub> Antenna Gain(dB)	Peak EIRP (dBm)	Limit (dBm)	Margin (dB)	Polarization
5070	-42.04	4.41	3.00	12.34	-34.11	-25.00	9.11	H
7605	-49.46	5.38	3.00	13.58	-41.26	-25.00	16.26	H
5070	-44.74	4.41	3.00	12.34	-36.81	-25.00	11.81	V
7605	-51.65	5.38	3.00	13.58	-43.45	-25.00	18.45	V

*LTE Band 7\_Channel Bandwidth 10MHz\_16QAM\_1RB#0\_High Channel*

Frequency (MHz)	Ps (dBm)	P <sub>cl</sub> (dB)	Diatance	G <sub>a</sub> Antenna Gain(dB)	Peak EIRP (dBm)	Limit (dBm)	Margin (dB)	Polarization
5130	-46.09	4.45	3.00	12.45	-38.09	-25.00	13.09	H
7695	-49.13	5.47	3.00	13.66	-40.94	-25.00	15.94	H
5130	-43.23	4.45	3.00	12.45	-35.23	-25.00	10.23	V
7695	-52.22	5.48	3.00	13.66	-44.04	-25.00	19.04	V

*LTE Band 7\_Channel Bandwidth 15MHz\_16QAM\_1RB#0\_Low Channel*

Frequency (MHz)	Ps (dBm)	P <sub>cl</sub> (dB)	Diatance	G <sub>a</sub> Antenna Gain(dB)	Peak EIRP (dBm)	Limit (dBm)	Margin (dB)	Polarization
5015	-41.62	4.39	3.00	12.34	-33.67	-25.00	8.67	H
7522.5	-51.36	5.31	3.00	13.52	-43.15	-25.00	18.15	H
5015	-43.99	4.39	3.00	12.34	-36.04	-25.00	11.04	V
7522.5	-53.72	5.31	3.00	13.52	-45.51	-25.00	20.51	V

*LTE Band 7\_Channel Bandwidth 15MHz\_16QAM\_1RB#0\_Middle Channel*

Frequency (MHz)	Ps (dBm)	P <sub>cl</sub> (dB)	Diatance	G <sub>a</sub> Antenna Gain(dB)	Peak EIRP (dBm)	Limit (dBm)	Margin (dB)	Polarization
5070	-42.57	4.41	3.00	12.34	-34.64	-25.00	9.64	H
7605	-50.04	5.38	3.00	13.58	-41.84	-25.00	16.84	H
5070	-44.71	4.41	3.00	12.34	-36.78	-25.00	11.78	V
7605	-51.73	5.38	3.00	13.58	-43.53	-25.00	18.53	V

*LTE Band 7\_Channel Bandwidth 15MHz\_16QAM\_1RB#0\_High Channel*

Frequency (MHz)	Ps (dBm)	P <sub>cl</sub> (dB)	Diatance	G <sub>a</sub> Antenna Gain(dB)	Peak EIRP (dBm)	Limit (dBm)	Margin (dB)	Polarization
5015	-45.27	4.45	3.00	12.45	-37.27	-25.00	12.27	H
7522.5	-49.86	5.47	3.00	13.66	-41.67	-25.00	16.67	H
5015	-43.82	4.45	3.00	12.45	-35.82	-25.00	10.82	V
7522.5	-52.46	5.48	3.00	13.66	-44.28	-25.00	19.28	V

*LTE Band 7\_Channel Bandwidth 20MHz\_16QAM\_1RB#0\_Low Channel*

Frequency (MHz)	Ps (dBm)	P <sub>cl</sub> (dB)	Diatance	G <sub>a</sub> Antenna Gain(dB)	Peak EIRP (dBm)	Limit (dBm)	Margin (dB)	Polarization
5020	-42.11	4.39	3.00	12.34	-34.16	-25.00	9.16	H
7530	-51.35	5.31	3.00	13.52	-43.14	-25.00	18.14	H
5020	-43.98	4.39	3.00	12.34	-36.03	-25.00	11.03	V
7530	-54.26	5.31	3.00	13.52	-46.05	-25.00	21.05	V

*LTE Band 7\_Channel Bandwidth 20MHz\_16QAM\_1RB#0\_Middle Channel*

Frequency (MHz)	Ps (dBm)	P <sub>cl</sub> (dB)	Diatance	G <sub>a</sub> Antenna Gain(dB)	Peak EIRP (dBm)	Limit (dBm)	Margin (dB)	Polarization
5070	-42.02	4.41	3.00	12.34	-34.09	-25.00	9.09	H
7605	-49.27	5.38	3.00	13.58	-41.07	-25.00	16.07	H
5070	-44.19	4.41	3.00	12.34	-36.26	-25.00	11.26	V
7605	-51.96	5.38	3.00	13.58	-43.76	-25.00	18.76	V

*LTE Band 7\_Channel Bandwidth 20MHz\_16QAM\_1RB#0\_High Channel*

Frequency (MHz)	Ps (dBm)	P <sub>cl</sub> (dB)	Diatance	G <sub>a</sub> Antenna Gain(dB)	Peak EIRP (dBm)	Limit (dBm)	Margin (dB)	Polarization
5120	-45.23	4.45	3.00	12.45	-37.23	-25.00	12.23	H
7680	-49.41	5.47	3.00	13.66	-41.22	-25.00	16.22	H
5120	-43.78	4.45	3.00	12.45	-35.78	-25.00	10.78	V
7680	-52.15	5.48	3.00	13.66	-43.97	-25.00	18.97	V



## 4.7 Frequency Stability

### LIMIT

According to §2.1055 requirement, the frequency stability shall be sufficient to ensure that the fundamental emissions stay within the authorized bands of operation and should not exceed 2.5ppm.

### TEST CONFIGURATION

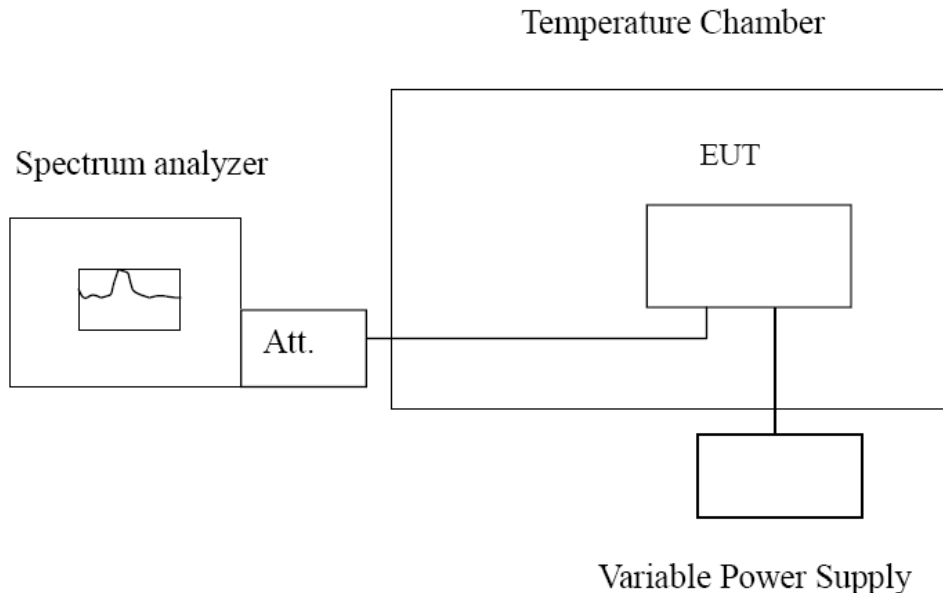

### TEST PROCEDURE

The EUT was setup according to EIA/TIA 603D

#### **Frequency Stability Under Temperature Variations:**

In order to measure the carrier frequency under the condition of AFC lock, it is necessary to make measurements with the EUT in a "call mode". This is accomplished with the use of R&S CMW500 DIGITAL RADIO COMMUNICATION TESTER.

1. Measure the carrier frequency at room temperature.
2. Subject the EUT to overnight soak at -30°C.
3. With the EUT, powered via nominal voltage, connected to the CMW500 and in a simulated call on middle channel for LTE band 41, measure the carrier frequency. These measurements should be made within 2 minutes of Powering up the EUT, to prevent significant self-warming.
4. Repeat the above measurements at 10°C increments from -30°C to +50°C. Allow at least 1.5 hours at each temperature, unpowered, before making measurements.
5. Re-measure carrier frequency at room temperature with nominal voltage. Vary supply voltage from minimum voltage to maximum voltage, in 0.1V increments re-measuring carrier frequency at each voltage. Pause at nominal voltage for 1.5 hours unpowered, to allow any self-heating to stabilize, before continuing.
6. Subject the EUT to overnight soak at +50°C.
7. With the EUT, powered via nominal voltage, connected to the CMW500 and in a simulated call on the centre channel, measure the carrier frequency. These measurements should be made within 2 minutes of Powering up the EUT, to prevent significant self-warming.
8. Repeat the above measurements at 10 °C increments from +50°C to -30°C. Allow at least 1.5 hours at each temperature, unpowered, before making measurements
9. At all temperature levels hold the temperature to +/- 0.5°C during the measurement procedure.

#### **Frequency Stability Under Voltage Variations:**

Set chamber temperature to 20°C. Use a variable AC power supply / DC power source to power the EUT and set the voltage to rated voltage. Set the spectrum analyzer RBW low enough to obtain the desired frequency resolution and recorded the frequency.

Reduce the input voltage to specify extreme voltage variation ( $\pm 15\%$ ) and endpoint, record the maximum frequency change.





**TEST RESULTS**

**N/A\***

Note: Test data refers to FCC ID: XMR201903EG25G, and report number is: HR/2019/100160.

## 5 Test Setup Photos of the EUT

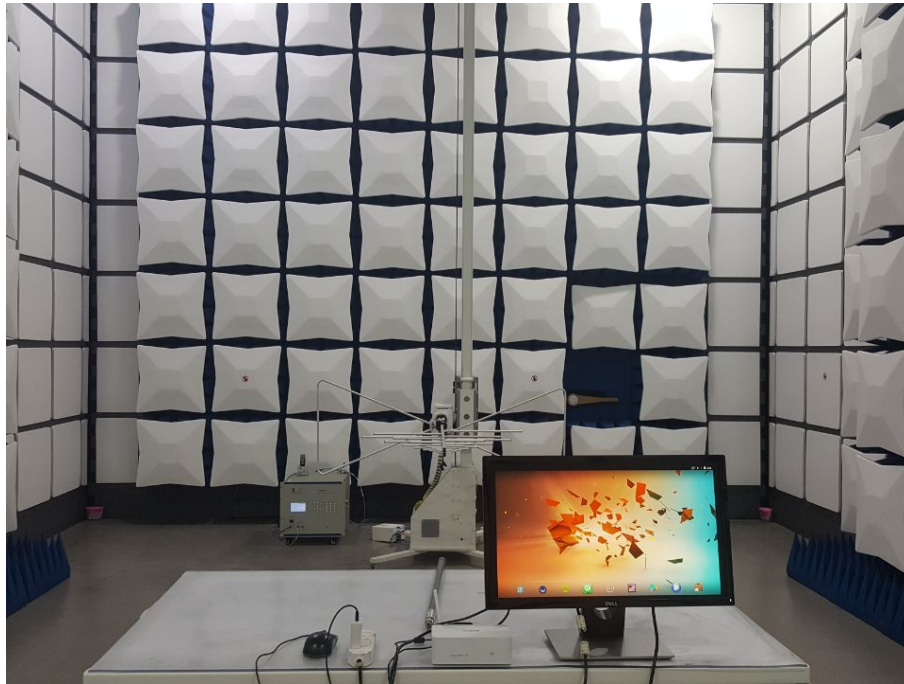



## **6 External and Internal Photos of the EUT**

Reference to the report :ANNEX A of external photos and ANNEX B of internal photos

**\*\*\*\*\*End of Report\*\*\*\*\***