



FCC TEST REPORT

**Test report
On Behalf of
Webee Corporation
For
Smartee G3
Model No.: SM3001, SM3001+, SM3001x, PCHQ1
FCC ID: 2AVI7-91DA3C**

Prepared for : Webee Corporation
SUITE# W014. 440 N. Wolfe Road, Sunnyvale, CA 94085

Prepared By : Shenzhen HUAKE Testing Technology Co., Ltd.
1F, B2 Building, Junfeng Zhongcheng Zhizao Innovation Park, Fuhai Street,
Bao'an District, Shenzhen City, China

Date of Test: Oct. 06, 2019 ~Oct. 12, 2019

Date of Report: Oct. 12, 2019

Report Number: HK1910082514-10E



TEST RESULT CERTIFICATION

Applicant's name: Webee Corporation
 Address: SUITE# W014. 440 N. Wolfe Road, Sunnyvale, CA 94085
Manufacture's Name.....: Webee Corporation
 Address: SUITE# W014. 440 N. Wolfe Road, Sunnyvale, CA 94085

Product description

Trade Mark: N/A
 Product name.....: Smartee G3
 Model and/or type reference .: SM3001, SM3001+, SM3001x, PCHQ1
Standards: FCC Rules and Regulations Part 15 Subpart C Section 15.407
 ANSI C63.10: 2013

This publication may be reproduced in whole or in part for non-commercial purposes as long as the Shenzhen HUAKE Testing Technology Co., Ltd. is acknowledged as copyright owner and source of the material. Shenzhen HUAKE Testing Technology Co., Ltd. takes no responsibility for and will not assume liability for damages resulting from the reader's interpretation of the reproduced material due to its placement and context.

Date of Test:
 Date (s) of performance of tests: Oct. 06, 2019 ~Oct. 12, 2019
 Date of Issue.....: Oct. 12, 2019
 Test Result.....: Pass

Testing Engineer : Gary Qian
 (Gary Qian)

Technical Manager : Eden Hu
 (Eden Hu)

Authorized Signatory : Jason Zhou
 (Jason Zhou)



TABLE OF CONTENTS

1. Test Result Summary	4
1.1. TEST PROCEDURES AND RESULTS.....	4
1.2. TEST FACILITY	4
1.3. MEASUREMENT UNCERTAINTY	5
2. EUT Description	6
2.1. GENERAL DESCRIPTION OF EUT	6
2.2. OPERATION FREQUENCY EACH OF CHANNEL.....	7
2.3. OPERATION OF EUT DURING TESTING	7
2.4. DESCRIPTION OF TEST SETUP	8
3. Genera Information	9
3.1. TEST ENVIRONMENT AND MODE	9
3.2. DESCRIPTION OF SUPPORT UNITS	10
4. Test Results and Measurement Data	11
4.1. CONDUCTED EMISSION	11
4.2. MAXIMUM CONDUCTED OUTPUT POWER	15
4.3. 6dB EMISSION BANDWIDTH	17
4.4. 26dB BANDWIDTH AND 99% OCCUPIED BANDWIDTH.....	24
4.5. POWER SPECTRAL DENSITY	25
4.6. BAND EDGE.....	32
4.7. SPURIOUS EMISSION	46
4.8. FREQUENCY STABILITY MEASUREMENT.....	54
4.9. ANTENNA REQUIREMENT	56
4.10. PHOTOGRAPHS OF TEST SETUP	57
4.11. PHOTOS OF THE EUT	59



1. Test Result Summary

1.1. TEST PROCEDURES AND RESULTS

Requirement	CFR 47 Section	Result
Antenna requirement	§15.203	PASS
AC Power Line Conducted Emission	§15.207	PASS
Maximum Conducted Output Power	§15.407(a)	PASS
6dB Emission Bandwidth	§15.407(e)	PASS
26dB Emission Bandwidth & 99% Occupied Bandwidth	§15.407(a)	N/A
Power Spectral Density	§15.407(a)	PASS
Band edge	§15.407(a)	PASS
Radiated Emission	§15.407(a)	PASS
Frequency Stability	§15.407(g)	PASS

Note:

1. PASS: Test item meets the requirement.
2. Fail: Test item does not meet the requirement.
3. N/A: Test case does not apply to the test object.
4. The test result judgment is decided by the limit of test standard.

1.2. TEST FACILITY

Test Firm : Shenzhen HUAKE Testing Technology Co., Ltd.

Address : 1F, B2 Building, Junfeng Zhongcheng Zhizao Innovation Park, Fuhai Street, Bao'an District, Shenzhen City, China



1.3. Measurement Uncertainty

The reported uncertainty of measurement $y \pm U$, where expanded uncertainty U is based on a standard uncertainty multiplied by a coverage factor of $k=2$, providing a level of confidence of approximately 95 %.

No.	Item	MU
1	Conducted Emission	$\pm 2.56\text{dB}$
2	RF power, conducted	$\pm 0.12\text{dB}$
3	Spurious emissions, conducted	$\pm 0.11\text{dB}$
4	All emissions, radiated(<1G)	$\pm 3.92\text{dB}$
5	All emissions, radiated(>1G)	$\pm 4.28\text{dB}$
6	Temperature	$\pm 0.1^\circ\text{C}$
7	Humidity	$\pm 1.0\%$



2. EUT Description

2.1. GENERAL DESCRIPTION OF EUT

Equipment	Smartee G3
Model Name	SM3001
Serial No.	SM3001+, SM3001x, PCHQ1
Trade Mark	N/A
Model Difference	All model's the function, software and electric circuit are the same, only with trade mark and model named different. Test sample model: SM3001
FCC ID	2AVI7-91DA3C
Operation Frequency:	IEEE 802.11a:5745-5825MHz
Modulation Technology:	IEEE 802.11a: BPSK,QPSK,16QAM,64QAM
Modulation Type	OFDM
Antenna Type	internal Antenna
Antenna Gain	2dBi
Power Source	DC5V/3A From Adapter
Power Supply:	DC5V/3A From Adapter



2.2. Operation Frequency each of channel

802.11a/802.11n(HT20) 802.11ac(HT20)		802.11n(HT40)/ 802.11ac(HT40)		802.11ac(HT80)	
Channel	Frequency	Channel	Frequency	Channel	Frequency
149	5745	151	5755	155	5775
153	5765	159	5790		
157	5785				
161	5805				
165	5825				

Note:

In section 15.31(m), regards to the operating frequency range over 10 MHz, the Lowest frequency, the middle frequency, and the highest frequency of channel were selected to perform the test, and the selected channel see below:

2.3. Operation of EUT during testing

Band IV (5725 - 5850 MHz)		
For 802.11a/ n HT20/ac HT 20		
Channel Number	Channel	Frequency (MHz)
149	Low	5745
157	Mid	5785
165	High	5825
For 802.11n HT40/ac HT 40		
Channel Number	Channel	Frequency (MHz)
151	Low	5755
159	High	5795
For 802.11n HT40/ac HT 40		
Channel Number	Channel	Frequency (MHz)
155	-	5775



2.4. DESCRIPTION OF TEST SETUP

Operation of EUT during Conducted, Radiation testing:

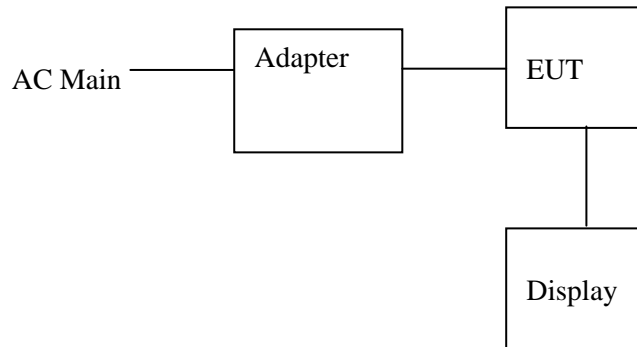

Operation of EUT during Above1GHz Radiation testing:

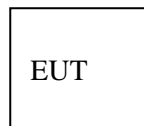

- Adapter information
Model: TEKA018-0503000UK
Input: 100-240V~ 50/60Hz, 0.5Amax
Output: 5V, 3000mA
- Display information
Model: 24PFF3661/T3
Input: AC 120V/60Hz



3. Genera Information

3.1. Test environment and mode

Operating Environment:	
Temperature:	25.0 °C
Humidity:	56 % RH
Atmospheric Pressure:	1010 mbar
Test Mode:	
Engineering mode:	Keep the EUT in continuous transmitting by select channel and modulations(The value of duty cycle is 100%)
<p>The sample was placed 0.8m/1.5m for blow/above 1GHz above the ground plane of 3m chamber. Measurements in both horizontal and vertical polarities were performed. During the test, each emission was maximized by: having the EUT continuously working, investigated all operating modes, rotated about all 3 axis (X, Y & Z) and considered typical configuration to obtain worst position, manipulating interconnecting cables, rotating the turntable, varying antenna height from 1m to 4m in both horizontal and vertical polarizations. The emissions worst-case are shown in Test Results of the following pages.</p>	

<p>We have verified the construction and function in typical operation. All the test modes were carried out with the EUT in transmitting operation, which was shown in this test report and defined as follows:</p>	
Per-scan all kind of data rate in lowest channel, and found the follow list which it was worst case.	
Mode	Data rate
802.11a	6 Mbps
Final Test Mode:	
Operation mode:	Keep the EUT in continuous transmitting with modulation



3.2. Description of Support Units

The EUT has been tested as an independent unit together with other necessary accessories or support units. The following support units or accessories were used to form a representative test configuration during the tests.

Equipment	Model No.	Serial No.	FCC ID	Trade Name
/	/	/	/	/

Note:

- 1. All the equipment/cables were placed in the worst-case configuration to maximize the emission during the test.*
- 2. Grounding was established in accordance with the manufacturer's requirements and conditions for the intended use.*
- 3. For conducted measurements (Output Power, Emission Bandwidth, Power Spectral Density, Spurious Emissions), the antenna of EUT is connected to the test equipment via temporary antenna connector, the antenna connector is soldered on the antenna port of EUT, and the temporary antenna connector is listed in the Test Instruments.*



4. Test Results and Measurement Data

4.1. Conducted Emission

4.1.1. Test Specification

Test Requirement:	FCC Part15 C Section 15.207														
Test Method:	ANSI C63.10:2013														
Frequency Range:	150 kHz to 30 MHz														
Receiver setup:	RBW=9 kHz, VBW=30 kHz, Sweep time=auto														
Limits:	<table border="1"> <thead> <tr> <th rowspan="2">Frequency range (MHz)</th> <th colspan="2">Limit (dBuV)</th> </tr> <tr> <th>Quasi-peak</th> <th>Average</th> </tr> </thead> <tbody> <tr> <td>0.15-0.5</td> <td>66 to 56*</td> <td>56 to 46*</td> </tr> <tr> <td>0.5-5</td> <td>56</td> <td>46</td> </tr> <tr> <td>5-30</td> <td>60</td> <td>50</td> </tr> </tbody> </table>	Frequency range (MHz)	Limit (dBuV)		Quasi-peak	Average	0.15-0.5	66 to 56*	56 to 46*	0.5-5	56	46	5-30	60	50
Frequency range (MHz)	Limit (dBuV)														
	Quasi-peak	Average													
0.15-0.5	66 to 56*	56 to 46*													
0.5-5	56	46													
5-30	60	50													
Test Setup:	<p><i>Remark</i> <i>E.U.T: Equipment Under Test</i> <i>LISN: Line Impedance Stabilization Network</i> <i>Test table height=0.8m</i></p>														
Test Mode:	Tx Mode														
Test Procedure:	<ol style="list-style-type: none"> 1. The E.U.T and simulators are connected to the main power through a line impedance stabilization network (L.I.S.N.). This provides a 50ohm/50uH coupling impedance for the measuring equipment. 2. The peripheral devices are also connected to the main power through a LISN that provides a 50ohm/50uH coupling impedance with 50ohm termination. (Please refer to the block diagram of the test setup and photographs). 3. Both sides of A.C. line are checked for maximum conducted interference. In order to find the maximum emission, the relative positions of equipment and all of the interface cables must be changed according to ANSI C63.10: 2013 on conducted measurement. 														
Test Result:	PASS														



4.1.2. Test Instruments

Conducted Emission Shielding Room Test Site (843)

Equipment	Manufacturer	Model	Serial Number	Calibration Date	Calibration Due
Receiver	R&S	ESCI 7	HKE-010	Dec. 28, 2018	Dec. 26, 2019
LISN	R&S	ENV216	HKE-002	Dec. 28, 2018	Dec. 26, 2019
Coax cable (9KHz-30MHz)	Times	381806-002	N/A	Dec. 28, 2018	Dec. 26, 2019
Conducted test software	Tonscend	TS+ Rev 2.5.0.0	HKE-081	N/A	N/A

Note: The calibration interval of the above test instruments is 12 months and the calibrations are traceable to international system unit (SI).



TEST RESULTS

PASS

All the test modes completed for test. only the worst result of AC240V/60Hz(802.11a at 5745MHz) was reported as below:

Conducted Emission on Line Terminal of the power line (150 kHz to 30MHz)

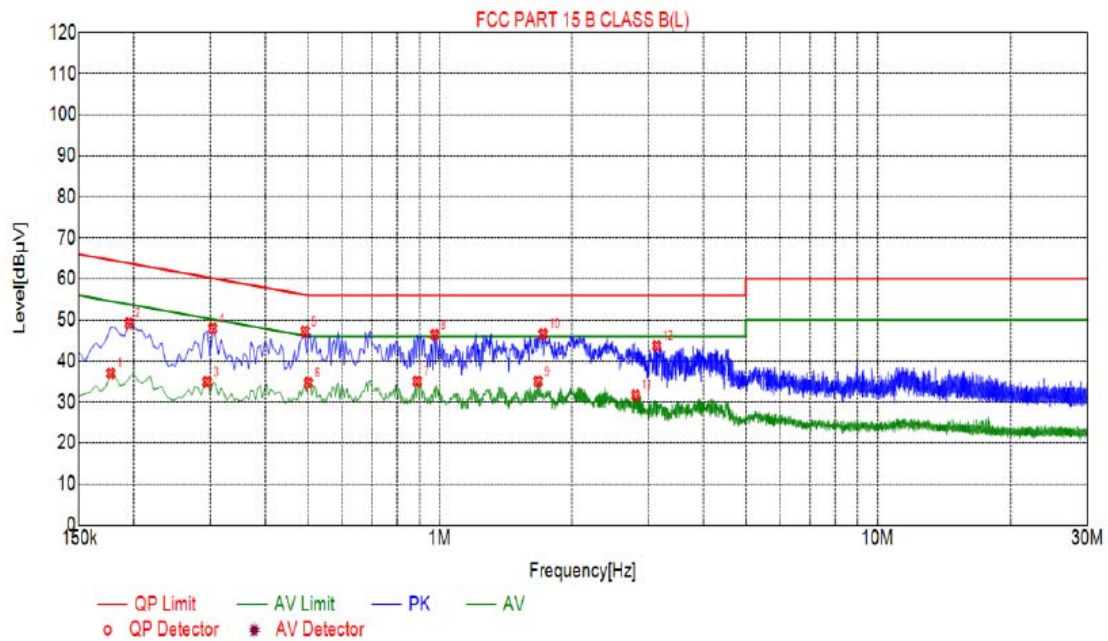

Suspected List

NO.	Freq. [MHz]	Level [dBμV]	Factor [dB]	Limit [dBμV]	Margin [dB]	Reading [dBμV]	Detector	Type
1	0.1770	36.99	10.05	54.63	17.64	26.94	AV	L
2	0.1950	49.16	10.03	63.82	14.66	39.13	PK	L
3	0.2940	34.91	10.03	50.41	15.50	24.88	AV	L
4	0.3030	47.95	10.04	60.16	12.21	37.91	PK	L
5	0.4920	47.24	10.04	56.13	8.89	37.20	PK	L
6	0.5010	34.64	10.04	46.00	11.36	24.60	AV	L
7	0.8880	35.08	10.06	46.00	10.92	25.02	AV	L
8	0.9735	46.40	10.06	56.00	9.60	36.34	PK	L
9	1.6755	35.04	10.13	46.00	10.96	24.91	AV	L
10	1.7205	46.54	10.13	56.00	9.46	36.41	PK	L
11	2.8005	31.65	10.21	46.00	14.35	21.44	AV	L
12	3.1290	43.69	10.23	56.00	12.31	33.46	PK	L

Remark: Margin = Limit – Level



Conducted Emission on Neutral Terminal of the power line (150 kHz to 30MHz)

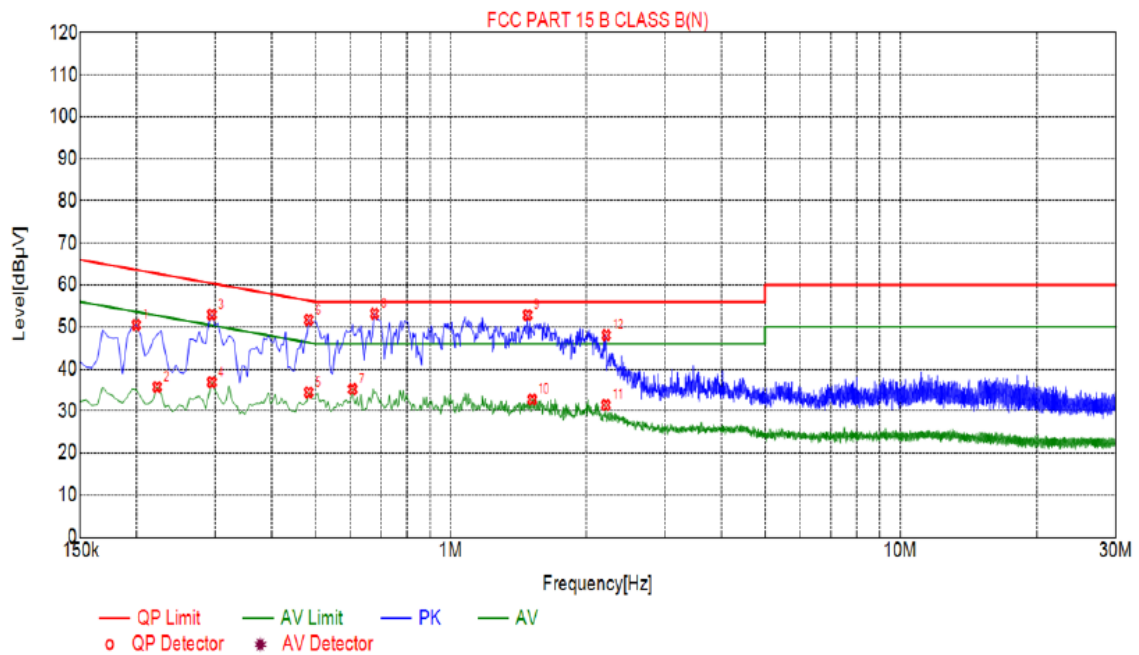

Suspected List								
NO.	Freq. [MHz]	Level [dBµV]	Factor [dB]	Limit [dBµV]	Margin [dB]	Reading [dBµV]	Detector	Type
1	0.1995	50.52	10.03	63.63	13.11	40.49	PK	N
2	0.2220	35.73	10.04	52.74	17.01	25.69	AV	N
3	0.2940	52.97	10.03	60.41	7.44	42.94	PK	N
4	0.2940	36.87	10.03	50.41	13.54	26.84	AV	N
5	0.4830	34.44	10.04	46.29	11.85	24.40	AV	N
6	0.4830	51.72	10.04	56.29	4.57	41.68	PK	N
7	0.6045	35.20	10.05	46.00	10.80	25.15	AV	N
8	0.6765	53.20	10.05	56.00	2.80	43.15	PK	N
9	1.4820	52.86	10.10	56.00	3.14	42.76	PK	N
10	1.5180	32.74	10.11	46.00	13.26	22.63	AV	N
11	2.2155	31.42	10.17	46.00	14.58	21.25	AV	N
12	2.2200	48.06	10.17	56.00	7.94	37.89	PK	N

Remark: Margin = Limit – Level



4.2. Maximum Conducted Output Power

4.2.1. Test Specification

Test Requirement:	FCC Part15 E Section 15.407(a)				
Test Method:	KDB789033 D02 General UNII Test Procedures New Rules v02.r01 Section E				
Limit:	<table border="1"> <thead> <tr> <th>Frequency Band (MHz)</th> <th>Limit</th> </tr> </thead> <tbody> <tr> <td>5725-5850</td> <td>1 W</td> </tr> </tbody> </table>	Frequency Band (MHz)	Limit	5725-5850	1 W
	Frequency Band (MHz)	Limit			
5725-5850	1 W				
Test Setup:	<p style="text-align: center;"> Power meter EUT </p>				
Test Mode:	Transmitting mode with modulation				
Test Procedure:	<ol style="list-style-type: none"> 1. The testing follows the Measurement Procedure of KDB789033 D02 General UNII Test Procedures New Rules v02r01 Section E, 3, a 2. The RF output of EUT was connected to the power meter by RF cable and attenuator. The path loss was compensated to the results for each measurement. 3. Set to the maximum power setting and enable the EUT transmit continuously. 5. Measure the conducted output power and record the results in the test report. 				
Test Result:	PASS				
Remark:	<p>Conducted output power= measurement power +10log(1/x) X is duty cycle=1, so 10log(1/1)=0</p> <p>Conducted output power= measurement power</p>				
<p>Note: The test double antenna is simultaneously transmitted, and the transmitting module is the same.</p>					



4.2.2. Test Instruments

RF Test Room					
Equipment	Manufacturer	Model	Serial Number	Calibration Date	Calibration Due
Spectrum analyzer	Agilent	N9020A	HKE-048	Dec. 28, 2018	Dec. 26, 2019
Power meter	Agilent	E4419B	HKE-085	Dec. 28, 2018	Dec. 26, 2019
Power Sensor	Agilent	E9300A	HKE-086	Dec. 28, 2018	Dec. 26, 2019
RF cable	Times	1-40G	HKE-034	Dec. 28, 2018	Dec. 26, 2019
RF automatic control unit	Tonscend	JS0806-2	HKE-060	Dec. 28, 2018	Dec. 26, 2019

Note: The calibration interval of the above test instruments is 12 months and the calibrations are traceable to international system unit (SI).

Test Data

Configuration Band IV (5725 - 5850 MHz)				
Mode	Test channel	Maximum Conducted Output Power (dBm)	FCC Limit (dBm)	Result
11a	CH149	13.85	30	PASS
11a	CH157	13.46	30	PASS
11a	CH165	13.47	30	PASS
11n HT20	CH149	12.86	30	PASS
11n HT20	CH157	12.69	30	PASS
11n HT20	CH165	12.63	30	PASS
11n HT40	CH151	12.78	30	PASS
11n HT40	CH159	12.82	30	PASS
11ac HT20	CH149	13.63	30	PASS
11ac HT20	CH157	13.19	30	PASS
11ac HT20	CH165	13.37	30	PASS
11ac HT40	CH151	12.17	30	PASS
11ac HT40	CH159	12.83	30	PASS
11ac HT80	CH155	11.77	30	PASS



4.3.3. Test data

Band IV (5725 - 5850 MHz)					
Mode	Test channel	Frequency (MHz)	6 dB Bandwidth (MHz)	Limit (MHz)	Result
11a	CH149	5745	15.17	0.5	PASS
11a	CH157	5785	15.04	0.5	PASS
11a	CH165	5825	15.11	0.5	PASS
11n HT20	CH149	5745	15.28	0.5	PASS
11n HT20	CH157	5785	15.16	0.5	PASS
11n HT20	CH165	5825	15.09	0.5	PASS
11n HT40	CH151	5755	35.17	0.5	PASS
11n HT40	CH159	5795	35.18	0.5	PASS
11ac HT20	CH149	5745	15.47	0.5	PASS
11ac HT20	CH157	5785	15.15	0.5	PASS
11ac HT20	CH165	5825	13.86	0.5	PASS
11ac HT40	CH151	5755	35.19	0.5	PASS
11ac HT40	CH159	5795	35.19	0.5	PASS
11ac HT80	CH155	5775	75.32	0.5	PASS

Test plots as follows:



Band IV (5725 – 5850 MHz)

802.11a



Low



Mid



High



802.11n HT20



Low



Mid



High



802.11n HT40

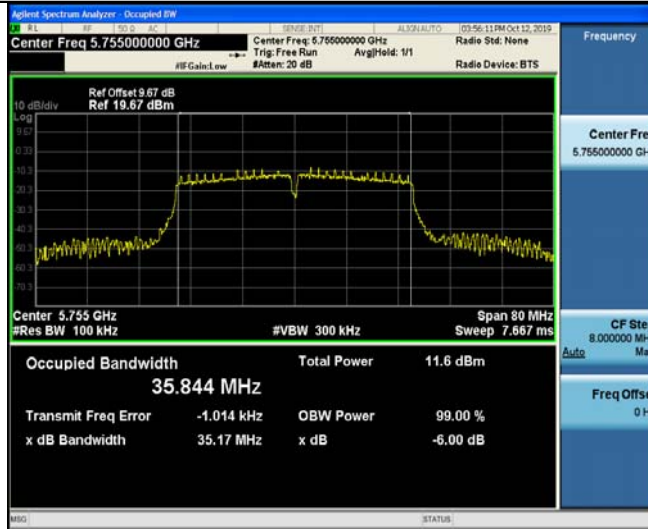

Low



High

802.11ac HT20



Low



Middle

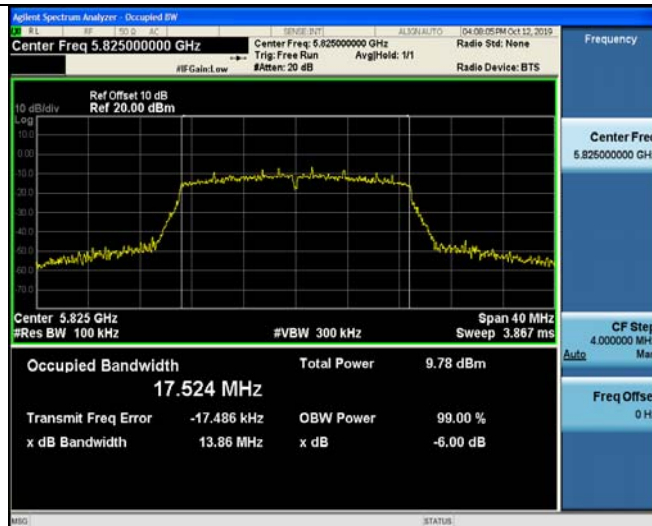

High
802.11ac HT40



Low

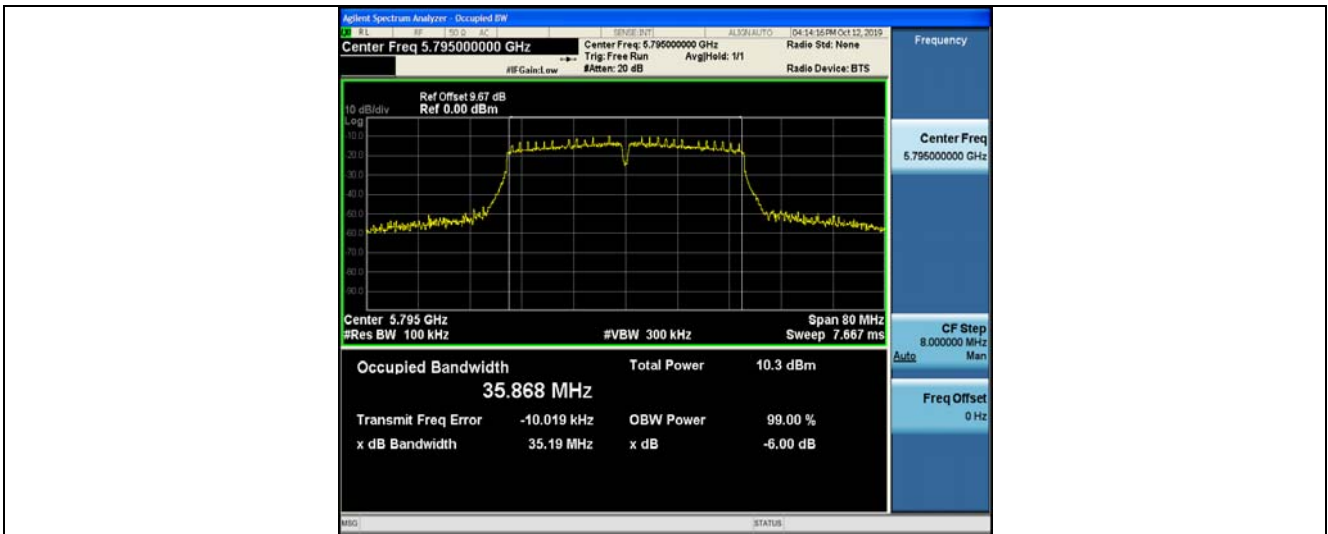

High
802.11ac HT80





4.5.3. Test data

Configuration Band IV (5725 - 5850 MHz)							
Mode	Test channel	Level [dBm/510kHz]	10log(1/x) Factor[dB]	10log(500/510)	Power Spectral Density	Limit (dBm/500kHz)	Result
11a	CH149	-1.26	0	-0.086	-1.346	30	PASS
11a	CH157	-1.59	0	-0.086	-1.676	30	PASS
11a	CH165	-1.91	0	-0.086	-1.996	30	PASS
11n HT20	CH149	-2.93	0	-0.086	-3.016	30	PASS
11n HT20	CH157	-3.29	0	-0.086	-3.376	30	PASS
11n HT20	CH165	-2.83	0	-0.086	-2.916	30	PASS
11n HT40	CH151	-5.43	0	-0.086	-5.516	30	PASS
11n HT40	CH159	-5.51	0	-0.086	-5.596	30	PASS
11ac HT20	CH149	-3.87	0	-0.086	-3.956	30	PASS
11ac HT20	CH157	-3.06	0	-0.086	-3.146	30	PASS
11ac HT20	CH165	-3.52	0	-0.086	-3.606	30	PASS
11ac HT40	CH151	-6.01	0	-0.086	-6.096	30	PASS
11ac HT40	CH159	-6.45	0	-0.086	-6.536	30	PASS
11ac HT80	CH155	-9.67	0	-0.086	-9.756	30	PASS

Test plots as follows:



Band IV (5725 – 5850 MHz)

802.11a



Low



Mid



High



802.11n HT20



Low



Mid



High



802.11n HT40



Low



High

802.11ac HT20

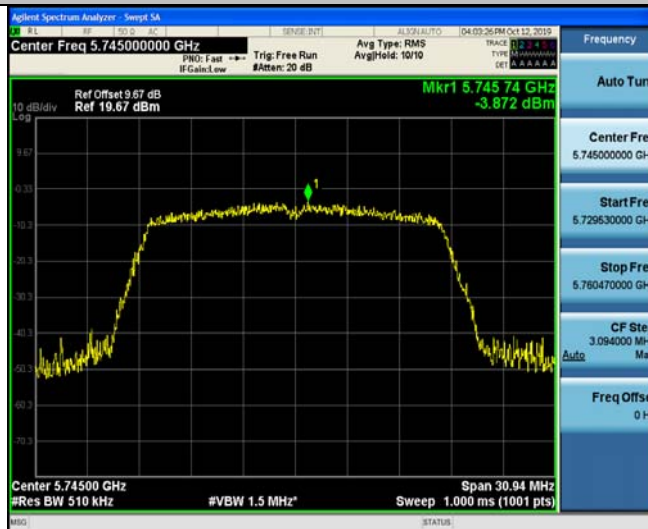

Low



Middle



High

802.11ac HT40



Low



High

802.11ac HT80





4.6. Band edge

4.6.1. Test Specification

Test Requirement:	FCC CFR47 Part 15E Section 15.407
Test Method:	ANSI C63.10 2013
Limit:	<p>For band I&II&III: $E[\text{dB}\mu\text{V}/\text{m}] = \text{EIRP}[\text{dBm}] + 95.2 = 68.2 \text{ dB}\mu\text{V}/\text{m}$, for $\text{EIRP}(\text{dBm}) = -27\text{dBm}$</p> <p>For transmitters operating in the 5.725-5.85 GHz band:</p> <p>All emissions shall be limited to a level of $-27 \text{ dBm}/\text{MHz}$ at 75 MHz or more above or below the band edge increasing linearly to $10 \text{ dBm}/\text{MHz}$ at 25 MHz above or below the band edge, and from 25 MHz above or below the band edge increasing linearly to a level of $15.6 \text{ dBm}/\text{MHz}$ at 5 MHz above or below the band edge, and from 5 MHz above or below the band edge increasing linearly to a level of $27 \text{ dBm}/\text{MHz}$ at the band edge.</p> <p>For band IV(5715-5725MHz&5850-5860MHz): $E[\text{dB}\mu\text{V}/\text{m}] = \text{EIRP}[\text{dBm}] + 95.2 = 78.2 \text{ dB}\mu\text{V}/\text{m}$, for $\text{EIRP}(\text{dBm}) = -27\text{dBm}$;</p> <p>For band IV(other un-restricted band): $E[\text{dB}\mu\text{V}/\text{m}] = \text{EIRP}[\text{dBm}] + 95.2 = 68.2 \text{ dB}\mu\text{V}/\text{m}$, for $\text{EIRP}(\text{dBm}) = -27\text{dBm}$</p>
Test Setup:	<p>The diagram illustrates the test setup. An Equipment Under Test (EUT) is placed on a rotating turn table at a height of 1.5 meters. The turn table is positioned 3 meters away from an antenna feed point. The antenna is mounted on a vertical tower that can be adjusted to heights between 1 and 4 meters. The entire setup is on a ground plane. A receiver and amplifier (Amp.) are connected to the antenna feed point.</p>
Test Mode:	Transmitting mode with modulation
Test Procedure:	<ol style="list-style-type: none"> 1. The EUT was placed on the top of a rotating table 0.8 meters above the ground at a 3 meter camber. The table was rotated 360 degrees to determine the position of the highest radiation. 2. The EUT was set 3 meters away from the interference-receiving antenna, which was mounted on the top of a variable-height antenna tower. 3. The antenna height is varied from one meter to four meters above the ground to determine the maximum value of the field strength. Both horizontal and vertical polarizations of the antenna are set to make the measurement. 4. For each suspected emission, the EUT was arranged to its worst case and then the antenna was tuned to heights from 1 meter to 4 meters and the rota table was



	<p>turned from 0 degrees to 360 degrees to find the maximum reading.</p> <p>5. The test-receiver system was set to Peak Detect Function and Specified Bandwidth with Maximum Hold Mode.</p> <p>6. If the emission level of the EUT in peak mode was 10dB lower than the limit specified, then testing could be stopped and the peak values of the EUT would be reported. Otherwise the emissions that did not have 10dB margin would be re-tested one by one using peak, quasipeak or average method as specified and then reported in a data sheet.</p>
Test Result:	PASS



4.6.2. Test Instruments

Radiated Emission Test Site (966)					
Name of Equipment	Manufacturer	Model	Serial Number	Calibration Date	Calibration Due
Receiver	R&S	ESRP3	HKE-005	Dec. 28, 2018	Dec. 26, 2019
Spectrum analyzer	Agilent	N9020A	HKE-048	Dec. 28, 2018	Dec. 26, 2019
Preamplifier	EMCI	EMC051845S E	HKE-015	Dec. 28, 2018	Dec. 26, 2019
Preamplifier	Agilent	83051A	HKE-016	Dec. 28, 2018	Dec. 26, 2019
Loop antenna	Schwarzbeck	FMZB 1519 B	HKE-014	Dec. 28, 2018	Dec. 26, 2019
Broadband antenna	Schwarzbeck	VULB 9163	HKE-012	Dec. 28, 2018	Dec. 26, 2019
Horn antenna	Schwarzbeck	9120D	HKE-013	Dec. 28, 2018	Dec. 26, 2019
Antenna Mast	Keleto	CC-A-4M	N/A	N/A	N/A
Position controller	Taiwan MF	MF7802	HKE-011	Dec. 28, 2018	Dec. 26, 2019
Radiated test software	Tonscend	TS+ Rev 2.5.0.0	HKE-082	N/A	N/A
RF cable (9KHz-1GHz)	Times	381806-001	N/A	N/A	N/A
Hf antenna	Schwarzbeck	LB-180400-KF	HKE-031	Dec. 28, 2018	Dec. 26, 2019
RF cable	Tonscend	1-18G	HKE-099	Dec. 28, 2018	Dec. 26, 2019
RF cable	Times	1-40G	HKE-034	Dec. 28, 2018	Dec. 26, 2019

Note: The calibration interval of the above test instruments is 12 months and the calibrations are traceable to international system unit (SI).



4.6.3. Test Data

Operation Mode: 802.11a Mode with 5.8G TX CH Low

Horizontal

Frequency	Meter Reading	Factor	Emission Level	Limits	Margin	Detector Type
(MHz)	(dB μ V)	(dB)	(dB μ V/m)	(dB μ V/m)	(dB)	
5650	58.14	-2.06	56.08	68.2	-12.12	peak
5650	39.63	-2.06	37.57	48.2	-10.63	AVG
5700	87.23	-1.96	85.27	105.2	-19.93	peak
5700	67.59	-1.96	65.63	85.2	-19.57	AVG
5720	90.22	-2.87	87.35	110.8	-23.45	peak
5720	77.56	-2.87	74.69	90.8	-16.11	AVG
5725	105.53	-2.14	103.39	122.2	-18.81	peak
5725	89.65	-2.14	87.51	102.2	-14.69	AVG

Remark: Factor = Antenna Factor + Cable Loss – Pre-amplifier.

Vertical:

Frequency	Meter Reading	Factor	Emission Level	Limits	Margin	Detector Type
(MHz)	(dB μ V)	(dB)	(dB μ V/m)	(dB μ V/m)	(dB)	
5650	59.03	-2.06	56.97	68.2	-11.23	peak
5650	37.89	-2.06	35.83	48.2	-12.37	AVG
5700	89.66	-1.96	87.7	105.2	-17.5	peak
5700	65.19	-1.96	63.23	85.2	-21.97	AVG
5720	95.02	-2.87	92.15	110.8	-18.65	peak
5720	78.64	-2.87	75.77	90.8	-15.03	AVG
5725	108.34	-2.14	106.2	122.2	-16	peak
5725	88.22	-2.14	86.08	102.2	-16.12	AVG

Remark: Factor = Antenna Factor + Cable Loss – Pre-amplifier.



Operation Mode: TX CH High with 5.8G

Horizontal

Frequency	Meter Reading	Factor	Emission Level	Limits	Margin	Detector Type
(MHz)	(dB μ V)	(dB)	(dB μ V/m)	(dB μ V/m)	(dB)	
5850	110.11	-1.97	108.14	122.2	-14.06	peak
5850	87.45	-1.97	85.48	102.2	-16.72	AVG
5855	95.68	-2.13	93.55	110.8	-17.25	peak
5855	76.12	-2.13	73.99	90.8	-16.81	AVG
5875	89.52	-2.65	86.87	105.2	-18.33	peak
5875	63.74	-2.65	61.09	85.2	-24.11	AVG
5925	56.29	-2.28	54.01	68.2	-14.19	peak
5925	38.22	-2.28	35.94	48.2	-12.26	AVG

Remark: Factor = Antenna Factor + Cable Loss – Pre-amplifier.

Vertical:

Frequency	Meter Reading	Factor	Emission Level	Limits	Margin	Detector Type
(MHz)	(dB μ V)	(dB)	(dB μ V/m)	(dB μ V/m)	(dB)	
5850	113.78	-1.97	111.81	122.2	-10.39	peak
5850	88.26	-1.97	86.29	102.2	-15.91	AVG
5855	95.49	-2.13	93.36	110.8	-17.44	peak
5855	77.58	-2.13	75.45	90.8	-15.35	AVG
5875	86.15	-2.65	83.5	105.2	-21.7	peak
5875	66.25	-2.65	63.6	85.2	-21.6	AVG
5925	56.78	-2.28	54.5	68.2	-13.7	peak
5925	37.66	-2.28	35.38	48.2	-12.82	AVG

Remark: Factor = Antenna Factor + Cable Loss – Pre-amplifier.



Operation Mode: 802.11n HT20 Mode with 5.8G TX CH Low

Horizontal

Frequency	Meter Reading	Factor	Emission Level	Limits	Margin	Detector Type
(MHz)	(dB μ V)	(dB)	(dB μ V/m)	(dB μ V/m)	(dB)	
5650	57.55	-2.06	55.49	68.2	-12.71	peak
5650	38.49	-2.06	36.43	48.2	-11.77	AVG
5700	88.37	-1.96	86.41	105.2	-18.79	peak
5700	66.42	-1.96	64.46	85.2	-20.74	AVG
5720	91.23	-2.87	88.36	110.8	-22.44	peak
5720	78.79	-2.87	75.92	90.8	-14.88	AVG
5725	102.45	-2.14	100.31	122.2	-21.89	peak
5725	87.59	-2.14	85.45	102.2	-16.75	AVG

Remark: Factor = Antenna Factor + Cable Loss – Pre-amplifier.

Vertical:

Frequency	Meter Reading	Factor	Emission Level	Limits	Margin	Detector Type
(MHz)	(dB μ V)	(dB)	(dB μ V/m)	(dB μ V/m)	(dB)	
5650	58.34	-2.06	56.28	68.2	-11.92	peak
5650	38.44	-2.06	36.38	48.2	-11.82	AVG
5700	88.26	-1.96	86.3	105.2	-18.9	peak
5700	64.19	-1.96	62.23	85.2	-22.97	AVG
5720	96.15	-2.87	93.28	110.8	-17.52	peak
5720	79.43	-2.87	76.56	90.8	-14.24	AVG
5725	107.03	-2.14	104.89	122.2	-17.31	peak
5725	87.48	-2.14	85.34	102.2	-16.86	AVG

Remark: Factor = Antenna Factor + Cable Loss – Pre-amplifier.



Operation Mode: TX CH High with 5.8G

Horizontal

Frequency	Meter Reading	Factor	Emission Level	Limits	Margin	Detector Type
(MHz)	(dB μ V)	(dB)	(dB μ V/m)	(dB μ V/m)	(dB)	
5850	106.13	-1.97	104.16	122.2	-18.04	peak
5850	68.32	-1.97	66.35	102.2	-35.85	AVG
5855	94.15	-2.13	92.02	110.8	-18.78	peak
5855	77.12	-2.13	74.99	90.8	-15.81	AVG
5875	88.59	-2.65	85.94	105.2	-19.26	peak
5875	64.03	-2.65	61.38	85.2	-23.82	AVG
5925	57.49	-2.28	55.21	68.2	-12.99	peak
5925	39.16	-2.28	36.88	48.2	-11.32	AVG

Remark: Factor = Antenna Factor + Cable Loss – Pre-amplifier.

Vertical:

Frequency	Meter Reading	Factor	Emission Level	Limits	Margin	Detector Type
(MHz)	(dB μ V)	(dB)	(dB μ V/m)	(dB μ V/m)	(dB)	
5850	110.06	-1.97	108.09	122.2	-14.11	peak
5850	87.88	-1.97	85.91	102.2	-16.29	AVG
5855	96.12	-2.13	93.99	110.8	-16.81	peak
5855	78.45	-2.13	76.32	90.8	-14.48	AVG
5875	85.39	-2.65	82.74	105.2	-22.46	peak
5875	67.88	-2.65	65.23	85.2	-19.97	AVG
5925	88.37	-2.28	86.09	68.2	17.89	peak
5925	36.49	-2.28	34.21	48.2	-13.99	AVG

Remark: Factor = Antenna Factor + Cable Loss – Pre-amplifier.



Operation Mode: 802.11n40 Mode with 5.8G TX CH Low

Horizontal

Frequency	Meter Reading	Factor	Emission Level	Limits	Margin	Detector Type
(MHz)	(dB μ V)	(dB)	(dB μ V/m)	(dB μ V/m)	(dB)	
5650	57.18	-2.06	55.12	68.2	-13.08	peak
5650	36.25	-2.06	34.19	48.2	-14.01	AVG
5700	90.22	-1.96	88.26	105.2	-16.94	peak
5700	71.38	-1.96	69.42	85.2	-15.78	AVG
5720	93.66	-2.87	90.79	110.8	-20.01	peak
5720	66.78	-2.87	63.91	90.8	-26.89	AVG
5725	112.45	-2.14	110.31	122.2	-11.89	peak
5725	90.7	-2.14	88.56	102.2	-13.64	AVG

Remark: Factor = Antenna Factor + Cable Loss – Pre-amplifier.

Vertical:

Frequency	Meter Reading	Factor	Emission Level	Limits	Margin	Detector Type
(MHz)	(dB μ V)	(dB)	(dB μ V/m)	(dB μ V/m)	(dB)	
5650	61.34	-2.06	59.28	68.2	-8.92	peak
5650	36.76	-2.06	34.7	48.2	-13.5	AVG
5700	94.25	-1.96	92.29	105.2	-12.91	peak
5700	70.85	-1.96	68.89	85.2	-16.31	AVG
5720	90.47	-2.87	87.6	110.8	-23.2	peak
5720	77.65	-2.87	74.78	90.8	-16.02	AVG
5725	112.44	-2.14	110.3	122.2	-11.9	peak
5725	80.46	-2.14	78.32	102.2	-23.88	AVG

Remark: Factor = Antenna Factor + Cable Loss – Pre-amplifier.



Operation Mode: TX CH High with 5.8G
Horizontal

Frequency	Meter Reading	Factor	Emission Level	Limits	Margin	Detector Type
(MHz)	(dB μ V)	(dB)	(dB μ V/m)	(dB μ V/m)	(dB)	
5850	110.05	-1.97	108.08	122.2	-14.12	peak
5850	91.13	-1.97	89.16	102.2	-13.04	AVG
5855	94.27	-2.13	92.14	110.8	-18.66	peak
5855	77.68	-2.13	75.55	90.8	-15.25	AVG
5875	89.22	-2.65	86.57	105.2	-18.63	peak
5875	67.34	-2.65	64.69	85.2	-20.51	AVG
5925	54.89	-2.28	52.61	68.2	-15.59	peak
5925	37.65	-2.28	35.37	48.2	-12.83	AVG

Remark: Factor = Antenna Factor + Cable Loss – Pre-amplifier.

Vertical:

Frequency	Meter Reading	Factor	Emission Level	Limits	Margin	Detector Type
(MHz)	(dB μ V)	(dB)	(dB μ V/m)	(dB μ V/m)	(dB)	
5850	108.16	-1.97	106.19	122.2	-16.01	peak
5850	94.36	-1.97	92.39	102.2	-9.81	AVG
5855	93.52	-2.13	91.39	110.8	-19.41	peak
5855	75.15	-2.13	73.02	90.8	-17.78	AVG
5875	85.31	-2.65	82.66	105.2	-22.54	peak
5875	63.01	-2.65	60.36	85.2	-24.84	AVG
5925	53.64	-2.28	51.36	68.2	-16.84	peak
5925	37.56	-2.28	35.28	48.2	-12.92	AVG

Remark: Factor = Antenna Factor + Cable Loss – Pre-amplifier.



Operation Mode: 802.11ac HT20 Mode with 5.8G TX CH Low

Horizontal

Frequency	Meter Reading	Factor	Emission Level	Limits	Margin	Detector Type
(MHz)	(dB μ V)	(dB)	(dB μ V/m)	(dB μ V/m)	(dB)	
5650	57.88	-2.06	55.82	68.2	-12.38	peak
5650	38.16	-2.06	36.1	48.2	-12.1	AVG
5700	88.45	-1.96	86.49	105.2	-18.71	peak
5700	68.92	-1.96	66.96	85.2	-18.24	AVG
5720	92.26	-2.87	89.39	110.8	-21.41	peak
5720	73.58	-2.87	70.71	90.8	-20.09	AVG
5725	111.32	-2.14	109.18	122.2	-13.02	peak
5725	88.23	-2.14	86.09	102.2	-16.11	AVG

Remark: Factor = Antenna Factor + Cable Loss – Pre-amplifier.

Vertical:

Frequency	Meter Reading	Factor	Emission Level	Limits	Margin	Detector Type
(MHz)	(dB μ V)	(dB)	(dB μ V/m)	(dB μ V/m)	(dB)	
5650	57.26	-2.06	55.2	68.2	-13	peak
5650	38.15	-2.06	36.09	48.2	-12.11	AVG
5700	91.64	-1.96	89.68	105.2	-15.52	peak
5700	69.11	-1.96	67.15	85.2	-18.05	AVG
5720	95.48	-2.87	92.61	110.8	-18.19	peak
5720	76.09	-2.87	73.22	90.8	-17.58	AVG
5725	113.65	-2.14	111.51	122.2	-10.69	peak
5725	91.37	-2.14	89.23	102.2	-12.97	AVG

Remark: Factor = Antenna Factor + Cable Loss – Pre-amplifier.



Operation Mode: TX CH High with 5.8G

Horizontal

Frequency	Meter Reading	Factor	Emission Level	Limits	Margin	Detector Type
(MHz)	(dB μ V)	(dB)	(dB μ V/m)	(dB μ V/m)	(dB)	
5850	110.66	-1.97	108.69	122.2	-13.51	peak
5850	89.15	-1.97	87.18	102.2	-15.02	AVG
5855	94.23	-2.13	92.1	110.8	-18.7	peak
5855	79.62	-2.13	77.49	90.8	-13.31	AVG
5875	87.12	-2.65	84.47	105.2	-20.73	peak
5875	68.03	-2.65	65.38	85.2	-19.82	AVG
5925	54.47	-2.28	52.19	68.2	-16.01	peak
5925	38.56	-2.28	36.28	48.2	-11.92	AVG

Remark: Factor = Antenna Factor + Cable Loss – Pre-amplifier.

Vertical:

Frequency	Meter Reading	Factor	Emission Level	Limits	Margin	Detector Type
(MHz)	(dB μ V)	(dB)	(dB μ V/m)	(dB μ V/m)	(dB)	
5850	111.12	-1.97	109.15	122.2	-13.05	peak
5850	87.69	-1.97	85.72	102.2	-16.48	AVG
5855	90.24	-2.13	88.11	110.8	-22.69	peak
5855	76.03	-2.13	73.9	90.8	-16.9	AVG
5875	85.78	-2.65	83.13	105.2	-22.07	peak
5875	72.63	-2.65	69.98	85.2	-15.22	AVG
5925	56.98	-2.28	54.7	68.2	-13.5	peak
5925	38.79	-2.28	36.51	48.2	-11.69	AVG

Remark: Factor = Antenna Factor + Cable Loss – Pre-amplifier.



Operation Mode: 802.11ac HT40 Mode with 5.8G TX CH Low

Horizontal

Frequency	Meter Reading	Factor	Emission Level	Limits	Margin	Detector Type
(MHz)	(dB μ V)	(dB)	(dB μ V/m)	(dB μ V/m)	(dB)	
5650	56.17	-2.06	54.11	68.2	-14.09	peak
5650	37.59	-2.06	35.53	48.2	-12.67	AVG
5700	88.75	-1.96	86.79	105.2	-18.41	peak
5700	67.25	-1.96	65.29	85.2	-19.91	AVG
5720	94.28	-2.87	91.41	110.8	-19.39	peak
5720	75.16	-2.87	72.29	90.8	-18.51	AVG
5725	110.32	-2.14	108.18	122.2	-14.02	peak
5725	90.85	-2.14	88.71	102.2	-13.49	AVG

Remark: Factor = Antenna Factor + Cable Loss – Pre-amplifier.

Vertical:

Frequency	Meter Reading	Factor	Emission Level	Limits	Margin	Detector Type
(MHz)	(dB μ V)	(dB)	(dB μ V/m)	(dB μ V/m)	(dB)	
5650	57.02	-2.06	54.96	68.2	-13.24	peak
5650	37.42	-2.06	35.36	48.2	-12.84	AVG
5700	88.69	-1.96	86.73	105.2	-18.47	peak
5700	67.45	-1.96	65.49	85.2	-19.71	AVG
5720	94.28	-2.87	91.41	110.8	-19.39	peak
5720	75.88	-2.87	73.01	90.8	-17.79	AVG
5725	110.12	-2.14	107.98	122.2	-14.22	peak
5725	90.02	-2.14	87.88	102.2	-14.32	AVG

Remark: Factor = Antenna Factor + Cable Loss – Pre-amplifier.



Operation Mode: TX CH High with 5.8G

Horizontal

Frequency	Meter Reading	Factor	Emission Level	Limits	Margin	Detector Type
(MHz)	(dB μ V)	(dB)	(dB μ V/m)	(dB μ V/m)	(dB)	
5850	110.15	-1.97	108.18	122.2	-14.02	peak
5850	93.14	-1.97	91.17	102.2	-11.03	AVG
5855	92.82	-2.13	90.69	110.8	-20.11	peak
5855	75.36	-2.13	73.23	90.8	-17.57	AVG
5875	88.52	-2.65	85.87	105.2	-19.33	peak
5875	65.13	-2.65	62.48	85.2	-22.72	AVG
5925	54.99	-2.28	52.71	68.2	-15.49	peak
5925	37.94	-2.28	35.66	48.2	-12.54	AVG

Remark: Factor = Antenna Factor + Cable Loss – Pre-amplifier.

Vertical:

Frequency	Meter Reading	Factor	Emission Level	Limits	Margin	Detector Type
(MHz)	(dB μ V)	(dB)	(dB μ V/m)	(dB μ V/m)	(dB)	
5850	112.32	-1.97	110.35	122.2	-11.85	peak
5850	90.35	-1.97	88.38	102.2	-13.82	AVG
5855	90.47	-2.13	88.34	110.8	-22.46	peak
5855	70.65	-2.13	68.52	90.8	-22.28	AVG
5875	87.16	-2.65	84.51	105.2	-20.69	peak
5875	64.35	-2.65	61.7	85.2	-23.5	AVG
5925	55.88	-2.28	53.6	68.2	-14.6	peak
5925	35.03	-2.28	32.75	48.2	-15.45	AVG

Remark: Factor = Antenna Factor + Cable Loss – Pre-amplifier.



Operation Mode: 802.11ac80 Mode with 5.8G TX CH Low

Horizontal

Frequency	Meter Reading	Factor	Emission Level	Limits	Margin	Detector Type
(MHz)	(dB μ V)	(dB)	(dB μ V/m)	(dB μ V/m)	(dB)	
5650	57.33	-2.06	55.27	68.2	-12.93	peak
5650	38.56	-2.06	36.5	48.2	-11.7	AVG
5700	88.02	-1.96	86.06	105.2	-19.14	peak
5700	67.55	-1.96	65.59	85.2	-19.61	AVG
5720	94.27	-2.87	91.4	110.8	-19.4	peak
5720	76.38	-2.87	73.51	90.8	-17.29	AVG
5725	110.32	-2.14	108.18	122.2	-14.02	peak
5725	90.48	-2.14	88.34	102.2	-13.86	AVG

Remark: Factor = Antenna Factor + Cable Loss – Pre-amplifier.

Vertical:

Frequency	Meter Reading	Factor	Emission Level	Limits	Margin	Detector Type
(MHz)	(dB μ V)	(dB)	(dB μ V/m)	(dB μ V/m)	(dB)	
5650	59.05	-2.06	56.99	68.2	-11.21	peak
5650	36.78	-2.06	34.72	48.2	-13.48	AVG
5700	91.23	-1.96	89.27	105.2	-15.93	peak
5700	67.25	-1.96	65.29	85.2	-19.91	AVG
5720	94.66	-2.87	91.79	110.8	-19.01	peak
5720	70.36	-2.87	67.49	90.8	-23.31	AVG
5725	114.32	-2.14	112.18	122.2	-10.02	peak
5725	94.65	-2.14	92.51	102.2	-9.69	AVG

Remark: Factor = Antenna Factor + Cable Loss – Pre-amplifier.



4.7. Spurious Emission

4.7.1.1. Test Specification

Test Requirement:	FCC CFR47 Part 15 Section 15.407 & 15.209 & 15.205				
Test Method:	KDB 789033 D02 v02r01				
Frequency Range:	9kHz to 40GHz				
Measurement Distance:	3 m				
Antenna Polarization:	Horizontal & Vertical				
Operation mode:	Transmitting mode with modulation				
Receiver Setup:	Frequency	Detector	RBW	VBW	Remark
	9kHz- 150kHz	Quasi-peak	200Hz	1kHz	Quasi-peak Value
	150kHz- 30MHz	Quasi-peak	9kHz	30kHz	Quasi-peak Value
	30MHz-1GHz	Quasi-peak	120KHz	300KHz	Quasi-peak Value
	Above 1GHz	Peak	1MHz	3MHz	Peak Value
Peak		1MHz	10Hz	Average Value	
Limit:	Unwanted spurious emissions fallen in restricted bands per FCC Part15.205 shall comply with the general field strength limits set forth in § 15.209 as below table,				
	Frequency	Field Strength (microvolts/meter)	Measurement Distance (meters)		
	0.009-0.490	2400/F(KHz)	300		
	0.490-1.705	24000/F(KHz)	30		
	1.705-30	30	30		
	30-88	100	3		
	88-216	150	3		
	216-960	200	3		
	Above 960	500	3		
	Frequency	Limit (dBuV/m @3m)	Detector		
Above 1G	74.0	Peak			
	54.0	Average			
Test setup:	For radiated emissions below 30MHz				
	<p>Distance = 3m</p> <p>EUT</p> <p>Turn table</p> <p>Ground Plane</p> <p>Pre -Amplifier</p> <p>Receiver</p> <p>Computer</p>				
30MHz to 1GHz					

	<p>Above 1GHz</p>
<p>Test Procedure:</p>	<ol style="list-style-type: none"> 1. The EUT was placed on the top of a rotating table 0.8 meters above the ground at a 3 meter camber. The table was rotated 360 degrees to determine the position of the highest radiation. 2. The EUT was set 3 meters away from the interference-receiving antenna, which was mounted on the top of a variable-height antenna tower. 3. The antenna height is varied from one meter to four meters above the ground to determine the maximum value of the field strength. Both horizontal and vertical polarizations of the antenna are set to make the measurement. 4. For each suspected emission, the EUT was arranged to its worst case and then the antenna was tuned to heights from 1 meter to 4 meters and the rotating table was turned from 0 degrees to 360 degrees to find the maximum reading. 5. The test-receiver system was set to Peak Detect Function and Specified Bandwidth with Maximum Hold Mode. 6. If the emission level of the EUT in peak mode was 10dB lower than the limit specified, then testing could be stopped and the peak values of the EUT would be reported. Otherwise the emissions that did not have 10dB margin would be re-tested one by one using peak, quasi-peak or average method as specified and then reported in a data sheet.
<p>Test results:</p>	<p>PASS</p>



4.7.2. Test Data

Remark: All the test modes completed for test. The worst case of Radiated Emission is CH 149; the test data of this mode was reported.

Below 1GHz

Horizontal

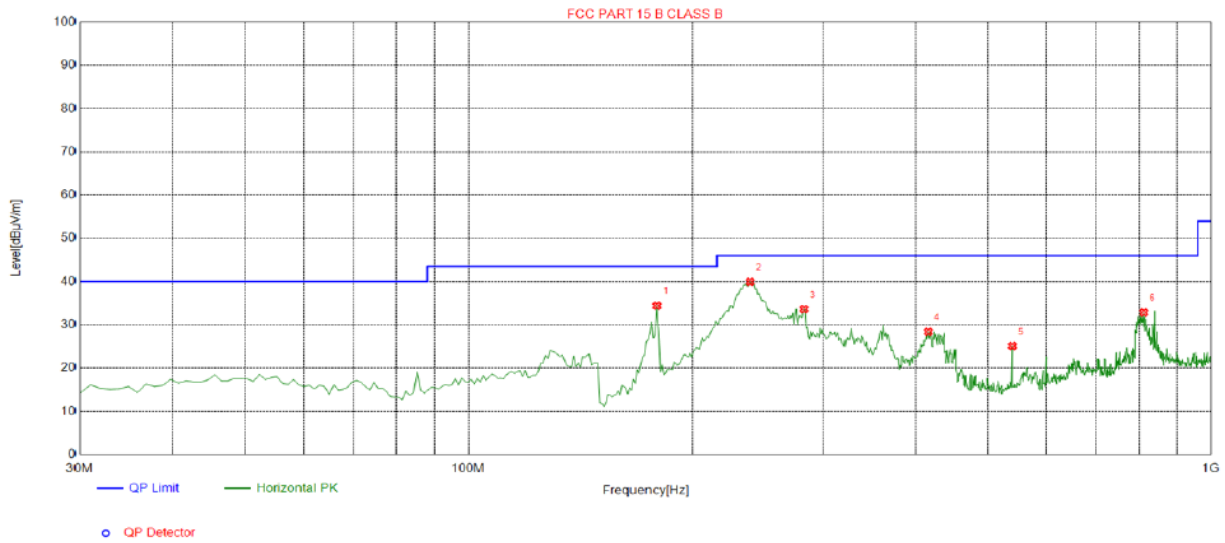

Suspected List									
NO	Freq. [MHz]	Factor [dB]	Reading [dBµV/m]	Level [dBµV/m]	Limit [dBµV/m]	Margin [dB]	Height [cm]	Angle [°]	Polarity
1	179.3800	-16.88	51.28	34.40	43.50	9.10	100	226	Horizontal
2	239.5200	-13.88	53.83	39.95	46.00	6.05	100	319	Horizontal
3	283.1700	-13.12	46.75	33.63	46.00	12.37	100	325	Horizontal
4	416.0600	-10.11	38.50	28.39	46.00	17.61	100	1	Horizontal
5	540.2200	-7.20	32.29	25.09	46.00	20.91	100	332	Horizontal
6	811.8200	-2.91	35.76	32.85	46.00	13.15	100	348	Horizontal

Remark: Transd = Cable lose + Antenna factor - Pre-amplifier; Margin = Limit – Level



Vertical

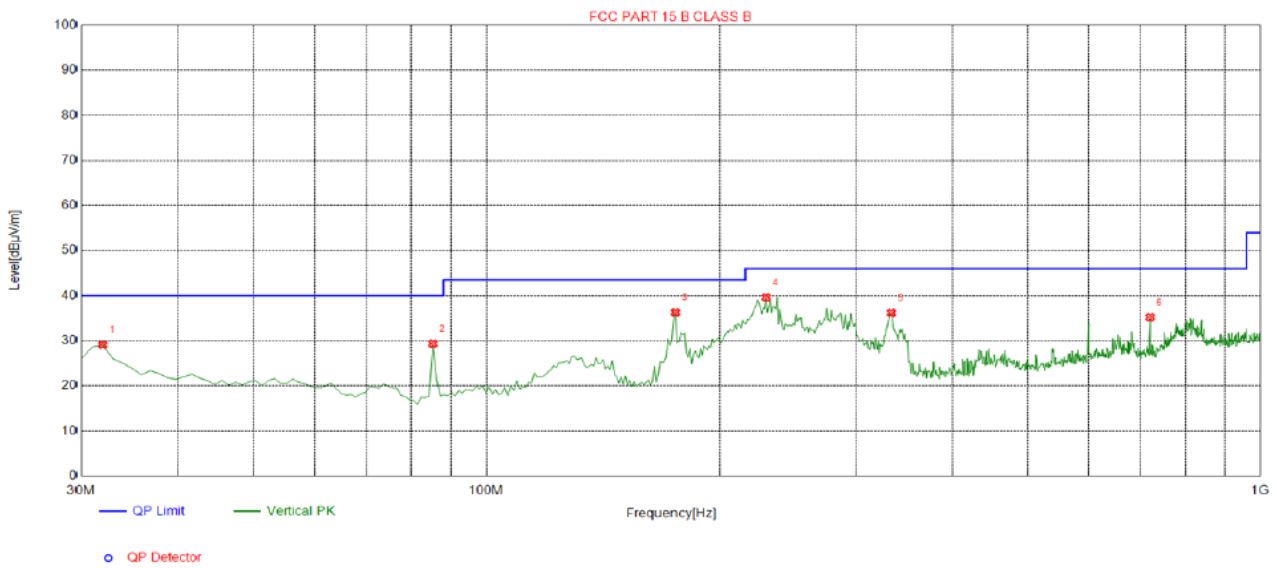

Suspected List									
NO	Freq. [MHz]	Factor [dB]	Reading [dBµV/m]	Level [dBµV/m]	Limit [dBµV/m]	Margin [dB]	Height [cm]	Angle [°]	Polarity
1	31.9400	-16.26	45.38	29.12	40.00	10.88	100	38	Vertical
2	85.2900	-18.20	47.56	29.36	40.00	10.64	100	191	Vertical
3	175.5000	-17.06	53.34	36.28	43.50	7.22	100	286	Vertical
4	229.8200	-14.32	53.94	39.62	46.00	6.38	100	18	Vertical
5	333.6100	-11.61	47.80	36.19	46.00	9.81	100	18	Vertical
6	720.6400	-4.70	39.93	35.23	46.00	10.77	100	236	Vertical

Remark: Factor = Antenna Factor + Cable Loss – Pre-amplifier.

Note: radiated emission which above the 15.209 is from unintentional part, which will be subject to 15.109



Harmonics and Spurious Emissions

Frequency Range (9 kHz-30MHz)

Frequency (MHz)	Level@3m (dB μ V/m)	Limit@3m (dB μ V/m)
--	--	--
--	--	--
--	--	--
--	--	--

- Note:** 1. *Emission Level=Reading+ Cable loss-Antenna factor-Amp factor*
2. *The emission levels are 20 dB below the limit value, which are not reported. It is deemed to comply with the requirement*

**Above 1GHz**

LOW CH 149 (802.11 a Mode with 5.8G)/5745

Horizontal:

Frequency	Meter Reading	Factor	Emission Level	Limits	Margin	Detector Type
(MHz)	(dB μ V)	(dB)	(dB μ V/m)	(dB μ V/m)	(dB)	
3647	64.72	-4.59	60.13	74	-13.87	peak
3647	47.25	-4.59	42.66	54	-11.34	AVG
11570	51.36	4.21	55.57	74	-18.43	peak
11570	38.55	4.21	42.76	54	-11.24	AVG

Remark: Factor = Antenna Factor + Cable Loss – Pre-amplifier.

Vertical:

Frequency	Meter Reading	Factor	Emission Level	Limits	Margin	Detector Type
(MHz)	(dB μ V)	(dB)	(dB μ V/m)	(dB μ V/m)	(dB)	
3647	63.17	-4.59	58.58	74	-15.42	peak
3647	48.66	-4.59	44.07	54	-9.93	AVG
11570	55.78	4.21	59.99	74	-14.01	peak
11570	37.46	4.21	41.67	54	-12.33	AVG

Remark: Factor = Antenna Factor + Cable Loss – Pre-amplifier.



MID CH157 (802.11 a Mode with 5.8G)/5785

Horizontal:

Frequency	Meter Reading	Factor	Emission Level	Limits	Margin	Detector Type
(MHz)	(dB μ V)	(dB)	(dB μ V/m)	(dB μ V/m)	(dB)	
3647	60.16	-4.59	55.57	74	-18.43	peak
3647	48.63	-4.59	44.04	54	-9.96	AVG
11570	54.79	4.21	59	74	-15	peak
11570	40.22	4.21	44.43	54	-9.57	AVG

Remark: Factor = Antenna Factor + Cable Loss – Pre-amplifier.

Vertical:

Frequency	Meter Reading	Factor	Emission Level	Limits	Margin	Detector Type
(MHz)	(dB μ V)	(dB)	(dB μ V/m)	(dB μ V/m)	(dB)	
3647	60.44	-4.59	55.85	74	-18.15	peak
3647	48.63	-4.59	44.04	54	-9.96	AVG
11570	51.55	4.21	55.76	74	-18.24	peak
11570	37.65	4.21	41.86	54	-12.14	AVG

Remark: Factor = Antenna Factor + Cable Loss – Pre-amplifier.



HIGH CH 165 (802.11a Mode with 5.8G)/5825

Horizontal:

Frequency	Meter Reading	Factor	Emission Level	Limits	Margin	Detector Type
(MHz)	(dB μ V)	(dB)	(dB μ V/m)	(dB μ V/m)	(dB)	
3647	61.78	-4.59	57.19	74	-16.81	peak
3647	49.65	-4.59	45.06	54	-8.94	AVG
11650	55.23	4.84	60.07	74	-13.93	peak
11650	39.64	4.84	44.48	54	-9.52	AVG

Remark: Factor = Antenna Factor + Cable Loss – Pre-amplifier.

Vertical:

Frequency	Meter Reading	Factor	Emission Level	Limits	Margin	Detector Type
(MHz)	(dB μ V)	(dB)	(dB μ V/m)	(dB μ V/m)	(dB)	
3647	58.06	-4.59	53.47	74	-20.53	peak
3647	48.65	-4.59	44.06	54	-9.94	AVG
11650	51.44	4.84	56.28	74	-17.72	peak
11650	38.69	4.84	43.53	54	-10.47	AVG

Remark: Factor = Antenna Factor + Cable Loss – Pre-amplifier.

Remark:

- (1) Measuring frequencies from 1 GHz to the 40 GHz.
- (2) "F" denotes fundamental frequency; "H" denotes spurious frequency. "E" denotes band edge frequency.
- (3) * denotes emission frequency which appearing within the Restricted Bands specified in provision of 15.205, then the general radiated emission limits in 15.209 apply.
- (4) Data of measurement within this frequency range shown "---" in the table above means the reading of emissions are attenuated more than 20dB below the permissible limits or the field strength is too small to be measured.
- (5) The IF bandwidth of EMI Test Receiver between 30MHz to 1GHz was 120KHz, 1 MHz for measuring above 1 GHz, below 30MHz was 10KHz.
- (6) When the test results of Peak Detected below the limits of Average Detected, the Average Detected is not need completed. For example: Top Channel at Fundamental 73.16dBuV/m(PK Value) <93.98(AV Limit), at harmonic 53.20 dBuV/m(PK Value) <54 dBuV/m(AV Limit), the Average Detected not need to completed.



4.8. Frequency Stability Measurement

4.8.1. Test Specification

Test Requirement:	FCC Part15 Section 15.407(g)
Test Method:	ANSI C63.10: 2013
Limit:	The frequency tolerance shall be maintained within the band of operation frequency over a temperature variation of 0 degrees to 35 degrees C at normal supply voltage, and for a variation in the primary supply voltage from 85% to 115% of the rated supply voltage at a temperature of 20 degrees C.
Test Setup:	<pre> graph LR SA[Spectrum Analyzer] --- EUT[EUT] subgraph TC [Temperature Chamber] EUT end P[AC/DC Power supply] --- EUT </pre>
Test Procedure:	The EUT was placed inside the environmental test chamber and powered by nominal AC/DC voltage. b. Turn the EUT on and couple its output to a spectrum analyzer. c. Turn the EUT off and set the chamber to the highest temperature specified. d. Allow sufficient time (approximately 30 min) for the temperature of the chamber to stabilize. e. Repeat step 2 and 3 with the temperature chamber set to the lowest temperature. f. The test chamber was allowed to stabilize at +20 degree C for a minimum of 30 minutes. The supply voltage was then adjusted on the EUT from 85% to 115% and the frequency record.
Test Result:	PASS
Remark:	N/A

**Test Result as follows:**

Mode	Voltage (V)	FHL (5745MHz)	Deviation (KHz)	FHH (5825MHz)	Deviation (KHz)
5.8G Band	5V	5744.996	19	5824.976	24
	5.5V	5745.030	15	5825.031	31
	4.5V	5745.012	14	5824.988	12

Mode	Temperature (°C)	FHL (5745MHz)	Deviation (KHz)	FHH (5825MHz)	Deviation (KHz)
5.8G Band	-30	5744.997	33	5824.962	14
	-20	5744.997	18	5824.988	19
	-10	5744.953	29	5825.037	28
	0	5745.043	22	5825.049	13
	10	5744.950	13	5825.015	15
	20	5745.012	8	5824.967	16
	30	5744.972	25	5825.028	21
	40	5744.998	21	5825.043	21
	50	5745.048	17	5825.016	18

4.9. ANTENNA REQUIREMENT

Standard Applicable

For intentional device, according to FCC 47 CFR Section 15.203, an intentional radiator shall be designed to ensure that no antenna other than that furnished by the responsible party shall be used with the device.

Refer to statement below for compliance.

The manufacturer may design the unit so that the user can replace a broken antenna, but the use of a standard antenna jack or electrical connector is prohibited. Further, this requirement does not apply to intentional radiators that must be professionally installed.

Antenna Connected Construction

The antenna used in this product is a Internal antenna, The directional gains of antenna used for transmitting is 2dBi.

WIFI ANTENNA

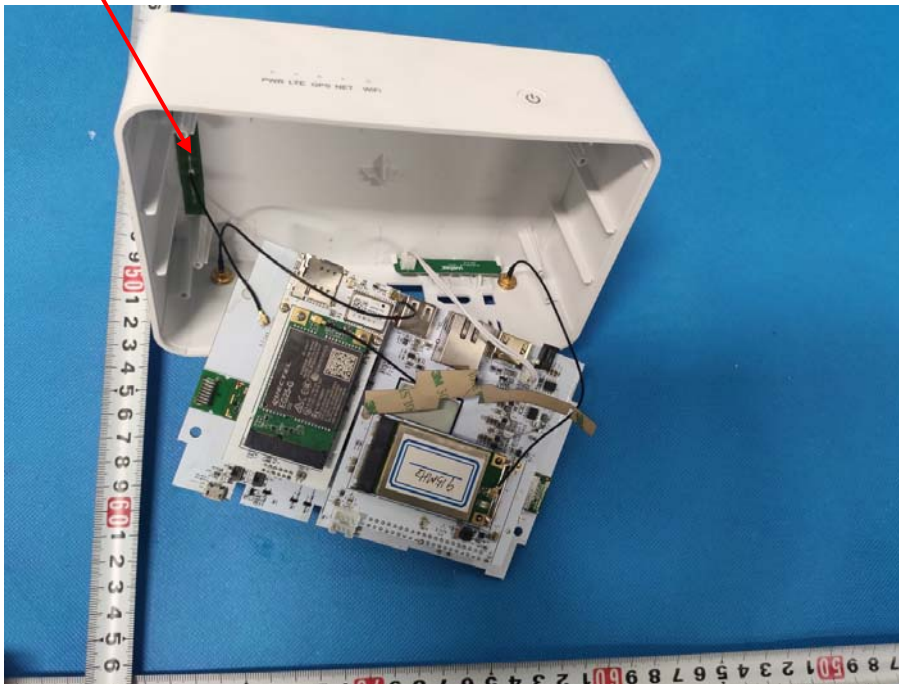

4.10. Photographs of Test Setup

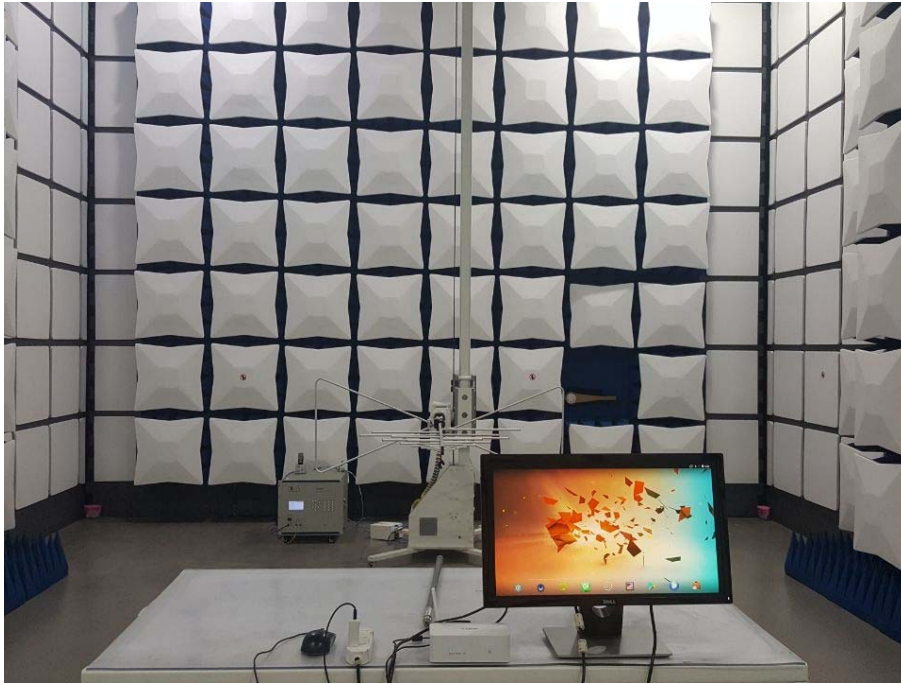





4.11. PHOTOS OF THE EUT

Reference to the reporter : ANNEX A of external photos and ANNEX B of internal photos

-----End of test report-----