

FCC Part 15.247

TEST REPORT

For

Toshiba Inspection Solutions Co., Ltd.

8, Shin Sugita-cho, Isogo-ku, Yokohama, Kanagawa Prefecture 235-8523 JAPAN

FCC ID: 2AVHN-TMRCD210TX

Report Type: Original Report	Product Type: RF 2.4G Remote Controller
Report Producer : <u>Coco Lin</u>	
Report Number : <u>RXZ230705015-02RF02</u>	
Report Date : <u>2024-05-13</u>	
Reviewed By: <u>Andy Shih</u> <i>Andy Shih</i>	
Prepared By: Bay Area Compliance Laboratories Corp. (New Taipei Laboratory) 70, Lane 169, Sec. 2, Datong Road, Xizhi Dist., New Taipei City 22183, Taiwan, R.O.C. Tel: +886 (2) 2647 6898 Fax: +886 (2) 2647 6895 www.bacl.com.tw	

Revision History

Revision	No.	Report Number	Issue Date	Description	Author/ Revised by
0.0	RXZ230705015-02	RXZ230705015-02RF02	2024-05-13	Original Report	Coco Lin

TABLE OF CONTENTS

1	General Information.....	5
1.1	Product Description for Equipment under Test (EUT)	5
1.2	Objective	6
1.3	Test Methodology.....	6
1.4	Statement.....	6
1.5	Measurement Uncertainty	7
1.6	Environmental Conditions.....	7
1.7	Test Facility	7
2	System Test Configuration.....	8
2.1	Description of Test Configuration.....	8
2.2	Equipment Modifications	8
2.3	EUT Exercise Software	8
2.4	Support Equipment List and Details.....	8
2.5	External Cable List and Details.....	8
2.6	Test Mode.....	9
2.7	Block Diagram of Test Setup	9
2.8	Duty Cycle.....	10
3	Summary of Test Results.....	11
4	Test Equipment List and Details	12
5	FCC §15.247(i), §1.1307(b)(3)(i) – RF Exposure.....	13
5.1	Applicable Standard	13
5.2	RF Exposure Evaluation Result.....	14
6	FCC §15.203 – Antenna Requirements.....	15
6.1	Applicable Standard	15
6.2	Antenna Information	15
7	FCC §15.209, §15.205 , §15.247(d) – Spurious Emissions	16
7.1	Applicable Standard	16
7.2	EUT Setup	17
7.3	EMI Test Receiver & Spectrum Analyzer Setup.....	18
7.4	Test Procedure.....	18
7.5	Corrected Factor & Margin Calculation.....	18
7.6	Test Results	19
8	FCC §15.247(a)(2) – 6 dB Emission Bandwidth.....	25
8.1	Applicable Standard.....	25
8.2	Test Procedure.....	25
8.3	Test Results	25
9	FCC §15.247(b)(3) – Maximum Output Power.....	28
9.1	Applicable Standard.....	28
9.2	Test Procedure.....	28
9.3	Test Results	28
10	FCC§15.247(d) – 100 kHz Bandwidth of Frequency Band Edge	29
10.1	Applicable Standard.....	29
10.2	Test Procedure.....	29
10.3	Test Results	29

11 FCC §15.247(e) – Power Spectral Density 31

11.1 Applicable Standard..... 31

11.2 Test Procedure..... 31

11.3 Test Results 31

1 General Information

1.1 Product Description for Equipment under Test (EUT)

Applicant	Toshiba Inspection Solutions Co., Ltd.
	8, Shin Sugita-cho, Isogo-ku, Yokohama, Kanagawa Prefecture 235-8523 JAPAN
Manufacturer	King Wins Technology Co., Ltd.
	11F., No.33, Ln. 332, Sec. 2, Zhongshan Rd., Zhonghe Dist., New Taipei City 235, Taiwan (R.O.C.)
Brand(Trade) Name	Toshiba
Product (Equipment)	RF 2.4G Remote Controller
Main Model Name	TMRC210TX
Frequency Range	2405 ~ 2476 MHz
Conducted Peak Output Power	-1.81 dBm
Modulation Technique	GFSK
Power Operation (Voltage Range)	<input type="checkbox"/> AC 120V/60Hz <input type="checkbox"/> Adapter <input type="checkbox"/> By AC Power Core
	<input checked="" type="checkbox"/> DC <input checked="" type="checkbox"/> Battery 3Vdc <input type="checkbox"/> DC Power Supply <input type="checkbox"/> External from USB Cable <input type="checkbox"/> External DC Adapter
	<input type="checkbox"/> Host System
Received Date	2023/07/19
Date of Test	2023/07/26 ~ 2024/05/09

*All measurement and test data in this report was gathered from production sample serial number: RXZ230705015-2 (Assigned by BACL, New Taipei Laboratory).

1.2 Objective

This report is prepared on behalf of *Toshiba Inspection Solutions Co., Ltd.* in accordance with Part 2, Subpart J, Part 15, Subparts A and C of the Federal Communication Commission's rules.

1.3 Test Methodology

All measurements contained in this report were conducted with ANSI C63.10-2013, American National Standard of Procedures for Compliance Testing of Unlicensed Wireless Devices.

KDB 558074 D01 15.247 Meas Guidance v05r02

1.4 Statement

Decision Rule: No, (The test results do not include MU judgment)

It may not be duplicated or used in part without prior written consent from Bay Area Compliance Laboratories Corp. (New Taipei Laboratory).

Any unauthorized alteration, forgery or falsification of the content or appearance of this document is unlawful and offenders may be prosecuted to the fullest extent of the law.

Unless otherwise stated the results shown in this test report refer only to the sample(s) tested.

The determination of the test results does not require consideration of the uncertainty of the measurement, unless the assessment is required by customer agreement, regulation or standard document specification.

Bay Area Compliance Laboratories Corp. (New Taipei Laboratory) is not responsible for the authenticity of the information provided by the applicant that affects the test results.

1.5 Measurement Uncertainty

Parameter		Uncertainty
RF output power, conducted		±3.74 dB
Power Spectral Density, conducted		±0.62 dB
Occupied Bandwidth		±0.09 %
Unwanted Emissions, conducted		±1.15 dB
Emissions, radiated	9 kHz~30 MHz	±3.54 dB
	30 MHz~1GHz	±4.99 dB
	1 GHz~18 GHz	±7.56 dB
	18 GHz~40 GHz	±5.06 dB
Temperature		±0.79 °C
Humidity		±0.44 %

Note: The extended uncertainty given in this report is obtained by combining the standard uncertainty times the coverage factor K with the 95% confidence interval. Otherwise required by the applicant or Product Regulations, Decision Rule in this report did not consider the uncertainty

1.6 Environmental Conditions

Test Site	Test Date	Temperature (°C)	Relative Humidity (%)	ATM Pressure (hPa)	Test Engineer
Radiation Spurious Emissions	2023/7/26~2024/5/9	23.1-23.7	50-65	1010	Aaron Pan
Conducted Spurious Emissions	2023/7/26	24.9	58	1010	Jing Chang
6 dB Emission Bandwidth	2023/7/26	24.9	58	1010	Jing Chang
Maximum Output Power	2023/7/26	24.9	58	1010	Jing Chang
100 kHz Bandwidth of Frequency Band Edge	2023/7/26	24.9	58	1010	Jing Chang
Power Spectral Density	2023/7/26	24.9	58	1010	Jing Chang

1.7 Test Facility

The Test site used by Bay Area Compliance Laboratories Corp. (New Taipei Laboratory) to collect test data is located on

70, Lane 169, Sec. 2, Datong Road, Xizhi Dist., New Taipei City 22183, Taiwan, R.O.C.

Bay Area Compliance Laboratories Corp. (New Taipei Laboratory) is accredited to ISO 17025 by Taiwan Accreditation Foundation (TAF code: 3732) and the FCC designation No.TW3732 under the Mutual Recognition Agreement (MRA) in FCC Test.

2 System Test Configuration

2.1 Description of Test Configuration

For SRD mode, 12 channels are provided to testing:

Channel	Freq. (MHz)
1	2405
2	2407
3	2408
4	2422
5	2423
6	2427
7	2447
8	2451
9	2452
10	2473
11	2474
12	2476

EUT was tested with Channel 1, 7 and 12.

2.2 Equipment Modifications

No modification was made to the EUT.

2.3 EUT Exercise Software

The test software was used “Pxi_Link_Emi_Tool v1.0.0.0.exe”

The system was configured for testing in engineering mode, which was provided by manufacturer.

Test Frequency	Low	Middle	High
Power Level Setting	4	0	0

2.4 Support Equipment List and Details

N/A.

2.5 External Cable List and Details

N/A.

2.6 Test Mode

Full System (model: TMRC210TX) for all test item.

2.7 Block Diagram of Test Setup

See test photographs attached in setup photos for the actual connections between EUT and support equipment.

Radiation:

Below 1GHz:

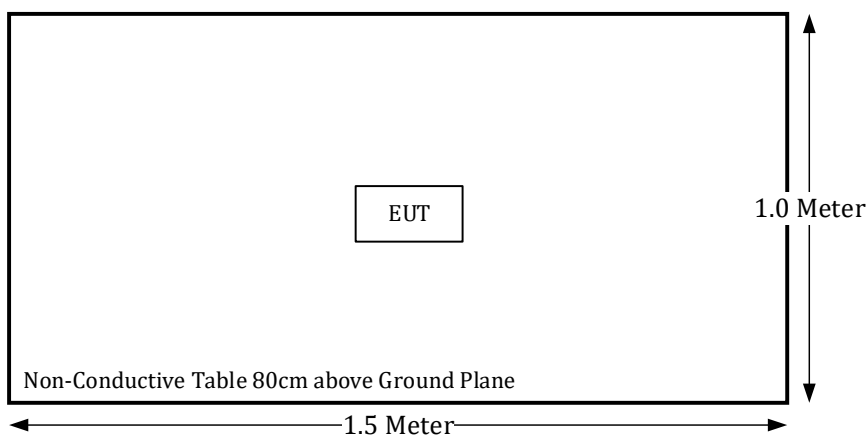

Above 1GHz:

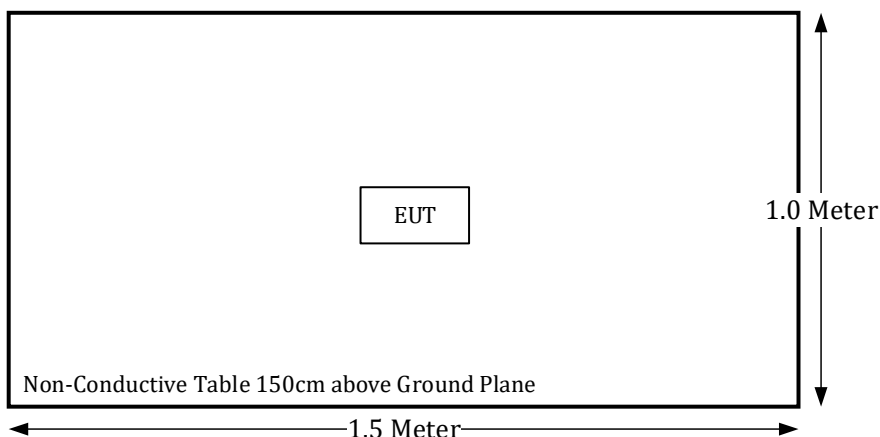

Conducted

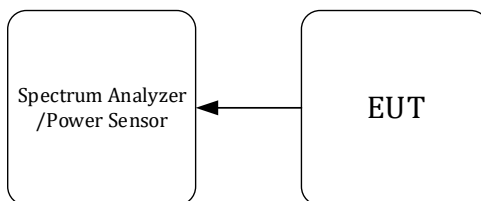

2.8 Duty Cycle

The duty cycle as below:

Radio Mode	On Time (ms)	Off Time (ms)	Duty Cycle (%)	1/T (kHz)	VBW setting (kHz)
SRD	0.338	0.274	55	2.959	3

Please refer to the following plots.

SRD Mode

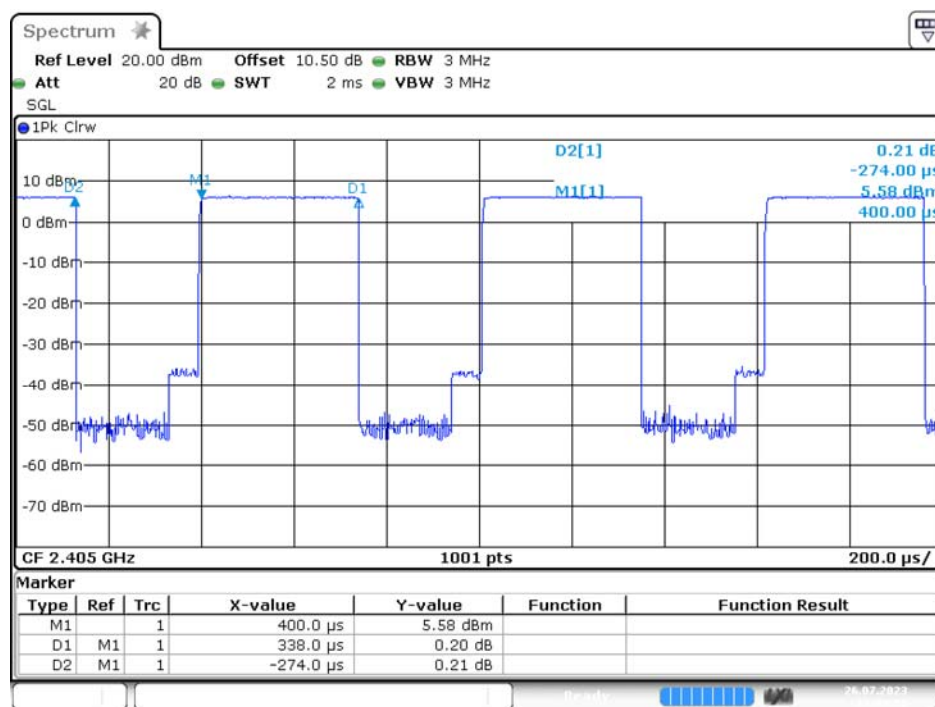

Date: 26 JUL 2023 11:08:58

3 Summary of Test Results

FCC Rules	Description of Test	Results
FCC §15.247(i), §1.1307(b)(3)(i)	RF Exposure	Compliance
§15.203	Antenna Requirement	Compliance
§15.207(a)	AC Line Conducted Emissions	Not applicable
§15.205, §15.209, §15.247(d)	Spurious Emissions	Compliance
§15.247(a)(2)	6 dB Emission Bandwidth	Compliance
§15.247(b)(3)	Maximum Peak Output Power	Compliance
§15.247(d)	100 kHz Bandwidth of Frequency Band Edge	Compliance
§15.247(e)	Power Spectral Density	Compliance

Not applicable: Device only supports battery.

4 Test Equipment List and Details

Description	Manufacturer	Model	Serial Number	Calibration Date	Calibration Due Date
Radiation 3M Room (966-A)					
Active Loop Antenna	ETS-Lindgren	6502	35796	2024/3/27	2025/3/26
Bilog Antenna with 6 dB Attenuator	SUNOL SCIENCES & MINI-CIRCUITS	JB6/UNAT-6+	A050115/1554_2_01	2023/2/2	2024/2/1
Horn Antenna	EMCO	SAS-571	1020	2023/5/18	2024/5/16
Horn Antenna	ETS-Lindgren	3116	62638	2022/8/18	2023/8/17
Preamplifier	Sonoma	310N	130602	2023/6/16	2024/6/14
Preamplifier	Channel	ERA-100M-18G-01D1748	EC2300051	2023/4/01	2024/3/30
Microwave Preamplifier	EM Electronics Corporation	EM18G40G	60656	2023/1/6	2024/1/5
Spectrum Analyzer	Rohde & Schwarz	FSV40	101939	2023/3/23	2024/3/22
				2024/3/27	2025/3/26
EMI Test Receiver	Rohde & Schwarz	ESR3	102099	2023/6/16	2024/6/14
Micro flex Cable	UTIFLEX	UFB197C-1-2362-70U-70U	225757-001	2023/1/24	2024/1/23
				2024/1/23	2025/1/21
Coaxial Cable	COMMATE	PEWC	8Dr	2022/12/24	2023/12/23
				2023/12/23	2024/12/21
Coaxial Cable	UTIFLEX	UFB311A-Q-1440-300300	220490-006	2023/1/24	2024/1/23
				2024/1/23	2025/1/21
Coaxial Cable	JUNFLON	J12J102248-00-B-5	AUG-07-15-044	2022/12/24	2023/12/23
				2023/12/23	2024/12/21
Cable	EMC	EMC105-SM-SM-10000	201003	2023/1/24	2024/1/23
				2024/1/23	2025/1/21
Coaxial Cable	ROSNOL	K1K50-UP0264-K1K50-450CM	160309-1	2023/1/24	2024/1/23
Coaxial Cable	ROSNOL	K1K50-UP0264-K1K50-50CM	15120-1	2023/2/2	2024/2/1
Software	AUDIX	E3	18621a	N.C.R	N.C.R
Conducted Room					
Spectrum Analyzer	Rohde & Schwarz	FSV40	101140	2023/2/10	2024/2/9
Cable	UTIFLEX	UFA210A	9435	2022/10/3	2023/10/2
Power Sensor	Boonton	RTP5006	11037	2023/5/23	2024/5/21
Attenuator	MINI-CIRCUITS	BW-S10W5+	1419	2023/2/2	2024/2/1

***Statement of Traceability:** BACL Corp. attests that all of the calibrations on the equipment items listed above were traceable to the SI System of Units via the R.O.C. Center for Measurement Standards of the Electronics Testing Center, Taiwan (ETC) or to another internationally recognized National Metrology Institute (NMI), and were compliant with the current Taiwan Accreditation Foundation (TAF) requirements.

5 FCC §15.247(i), §1.1307(b)(3)(i) – RF Exposure

5.1 Applicable Standard

According to subpart 15.247(i) and subpart §1.1310, systems operating under the provisions of this section shall be operated in a manner that ensures that the public is not exposed to radio frequency energy level in excess of the Commission’s guidelines.

For single RF sources (i.e., any single fixed RF source, mobile device, or portable device, as defined in paragraph (b)(2) of this section): A single RF source is exempt if:

(A) The available maximum time-averaged power is no more than 1 mW, regardless of separation distance. This exemption may not be used in conjunction with other exemption criteria other than those in paragraph (b)(3)(ii)(A) of this section. Medical implant devices may only use this exemption and that in paragraph (b)(3)(ii)(A);

(B) Or the available maximum time-averaged power or effective radiated power (ERP), whichever is greater, is less than or equal to the threshold P_{th} (mW) described in the following formula. This method shall only be used at separation distances (cm) from 0.5 centimeters to 40 centimeters and at frequencies from 0.3 GHz to 6 GHz (inclusive). P_{th} is given by:

$$P_{th} \text{ (mW)} = \begin{cases} ERP_{20 \text{ cm}} (d/20 \text{ cm})^x & d \leq 20 \text{ cm} \\ ERP_{20 \text{ cm}} & 20 \text{ cm} < d \leq 40 \text{ cm} \end{cases}$$

Where

$$x = -\log_{10} \left(\frac{60}{ERP_{20 \text{ cm}} \sqrt{f}} \right) \text{ and } f \text{ is in GHz;}$$

and

$$ERP_{20 \text{ cm}} \text{ (mW)} = \begin{cases} 2040f & 0.3 \text{ GHz} \leq f < 1.5 \text{ GHz} \\ 3060 & 1.5 \text{ GHz} \leq f \leq 6 \text{ GHz} \end{cases}$$

(C) Or using Table 1 and the minimum separation distance (R in meters) from the body of a nearby person for the frequency (f in MHz) at which the source operates, the ERP (watts) is no more than the calculated value prescribed for that frequency. For the exemption in Table 1 to apply, R must be at least λ/2π, where λ is the free-space operating wavelength in meters. If the ERP of a single RF source is not easily obtained, then the available maximum time-averaged power may be used in lieu of ERP if the physical dimensions of the radiating structure(s) do not exceed the electrical length of λ/4 or if the antenna gain is less than that of a half-wave dipole (1.64 linear value).

Table 1 to § 1.1307(b)(3)(i)(C) - Single RF Sources Subject to Routine Environmental Evaluation

RF Source frequency (MHz)	Threshold ERP (watts)
0.3-1.34	1,920 R ² .
1.34-30	3,450 R ² /f ² .
30-300	3.83 R ² .
300-1,500	0.0128 R ² f.
1,500-100,000	19.2R ² .

5.2 RF Exposure Evaluation Result

Project info

Band	Freq (MHz)	Tune-up Power (dBm)	Ant Gain (dBi)	Distances (mm)	Tune-up Power (mW)	ERP (dBm)	ERP (mW)
SRD Mode	2476	-1.5	0.5	5	0.71	-3.15	0.48

§ 1.1307(b)(3)(i)(A)

Determination of 1 mW blanket exemption under § 1.1307(b)(3)(i)(A)

Band	Freq (MHz)	Result Option A
SRD Mode	2476	exempt

The available maximum time-averaged power is no more than 1 mW

Result: The EUT meets exemption requirement.

6 FCC §15.203 – Antenna Requirements

6.1 Applicable Standard

According to § 15.203,

An intentional radiator shall be designed to ensure that no antenna other than that furnished by the responsible party shall be used with the device. The use of a permanently attached antenna or of an antenna that uses a unique coupling to the intentional radiator shall be considered sufficient to comply with the provisions of this section. The manufacturer may design the unit so that a broken antenna can be replaced by the user, but the user of a standard antenna jack or electrical connector is prohibited.

And according to FCC 47 CFR section 15.247 (b), if the transmitting antennas of directional gain greater than 6dBi are used, the power shall be reduced by the amount in dB that the directional gain of the antenna does not exceed 6dBi.

6.2 Antenna Information

Manufacturer	Model	Type	Antenna Gain
King Wins Technology Co., Ltd	TMRC210TX	PCB Antenna	0.5 dBi

Result: Compliance

7 FCC §15.209, §15.205 , §15.247(d) – Spurious Emissions

7.1 Applicable Standard

As per FCC §15.35(d): Unless otherwise specified, on any frequency or frequencies above 1000 MHz, the radiated emission limits are based on the use of measurement instrumentation employing an average detector function. Unless otherwise specified, measurements above 1000 MHz shall be performed using a minimum resolution bandwidth of 1MHz.

As Per FCC §15.205(a) except as show in paragraph (d) of this section, only spurious emissions are permitted in any of the frequency bands listed below:

MHz	MHz	MHz	GHz
0.090 – 0.110	16.42 – 16.423	608 – 614	4.5 – 5.15
0.495 – 0.505	16.69475 – 16.69525	960 – 1240	5.35 – 5.46
2.1735 – 2.1905	16.80425 – 16.80475	1300 – 1427	7.25 – 7.75
4.125 – 4.128	25.5 – 25.67	1435 – 1626.5	8.025 – 8.5
4.17725 – 4.17775	37.5 – 38.25	1645.5 – 1646.5	9.0 – 9.2
4.20725 – 4.20775	73 – 74.6	1660 – 1710	9.3 – 9.5
6.215 – 6.218	74.8 – 75.2	1718.8 – 1722.2	10.6 – 12.7
6.26775 – 6.26825	108 – 121.94	2200 – 2300	13.25 – 13.4
6.31175 – 6.31225	123 – 138	2310 – 2390	14.47 – 14.5
8.291 – 8.294	149.9 – 150.05	2483.5 – 2500	15.35 – 16.2
8.362 – 8.366	156.52475 – 156.52525	2690 – 2900	17.7 – 21.4
8.37625 – 8.38675	156.7 – 156.9	3260 – 3267	22.01 – 23.12
8.41425 – 8.41475	162.0125 – 167.17	3.332 – 3.339	23.6 – 24.0
12.29 – 12.293	167.72 – 173.2	3.3458 – 3.358	31.2 – 31.8
12.51975 – 12.52025	240 – 285	3.600 – 4.400	36.43 – 36.5
12.57675 – 12.57725	322 – 335.4		Above 38.6
13.36 – 13.41	399.9 – 410		

As per FCC §15.209(a): Except as provided elsewhere in this Subpart, the emissions from an intentional radiator shall not exceed the field strength levels specified in the following table:

Frequency (MHz)	Field Strength (micro volts/meter)	Measurement Distance (meters)
0.009 - 0.490	2400/F(kHz)	300
0.490 - 1.705	24000/F(kHz)	30
1.705 - 30.0	30	30
30 - 88	100**	3
88 - 216	150**	3
216 - 960	200**	3
Above 960	500	3

** Except as provided in paragraph (g), fundamental emissions from intentional radiators operating under this Section shall not be located in the frequency bands 54-72 MHz, 76-88 MHz, 174-216 MHz or 470-806 MHz. However, operation within these frequency bands is permitted under other sections of this Part, e.g., Sections 15.231 and 15.241.

As per FCC §15.247 (d) In any 100 kHz bandwidth outside the frequency band in which the spread spectrum or digitally modulated intentional radiator is operating, the radio frequency power that is produced by the

intentional radiator shall be at least 20 dB below that in the 100 kHz bandwidth within the band that contains the highest level of the desired power, based on either an RF conducted or a radiated measurement, provided the transmitter demonstrates compliance with the peak conducted power limits. If the transmitter complies with the conducted power limits based on the use of RMS averaging over a time interval, as permitted under paragraph (b)(3) of this section, the attenuation required under this paragraph shall be 30 dB instead of 20 dB. Attenuation below the general limits specified in §15.209(a) is not required. In addition, radiated emissions which fall in the restricted bands, as defined in §15.205(a), must also comply with the radiated emission limits specified in §15.209(a) (see §15.205(c)).

7.2 EUT Setup

9kHz-30MHz:

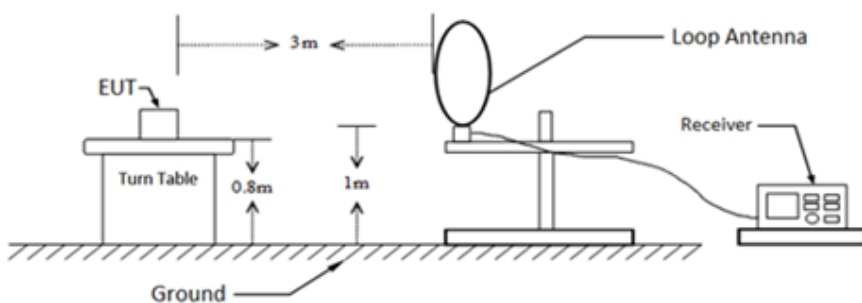

30MHz-1GHz:

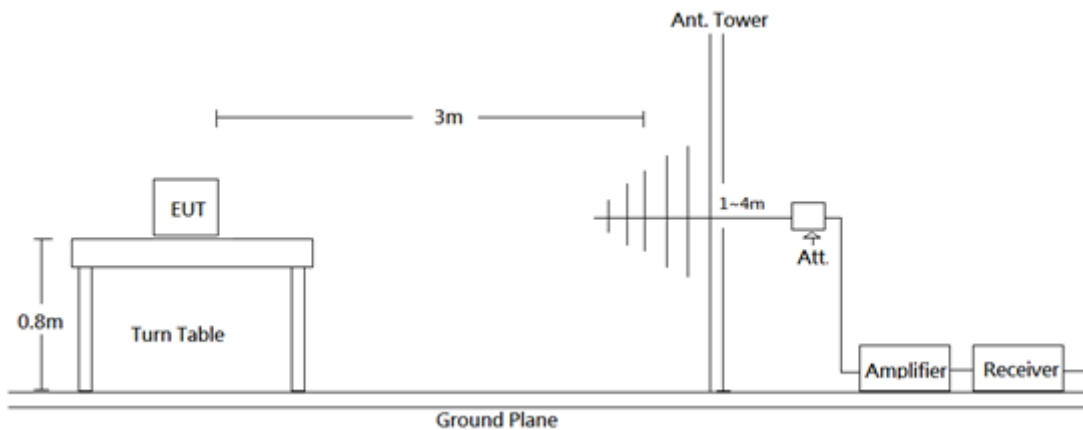

Above 1 GHz:

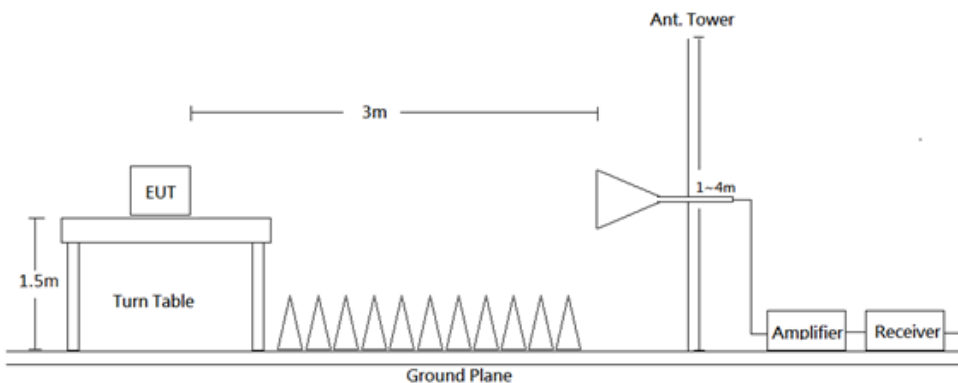

Radiated emission tests were performed in the 3 meters chamber test site, using the setup accordance with the ANSI C63.10-2013. The specification used was the FCC Part 15.209 and FCC 15.247 Limits.

7.3 EMI Test Receiver & Spectrum Analyzer Setup

The system was investigated from 30 MHz to 26.5 GHz. During the radiated emission test, the EMI test receiver was set with the following configurations measurement method 6.3 in ANSI C63.10.

Frequency Range	RBW	VBW	Duty cycle	Measurement method
9 kHz - 150 kHz	200 Hz/300 Hz	1 kHz	/	QP/AV
150 kHz - 30 MHz	9 kHz/10 kHz	30 kHz	/	QP/AV
30-1000 MHz	120 kHz	300 kHz	/	QP
Above 1 GHz	1 MHz	3 MHz	/	PK
	1 MHz	10 Hz	>98%	Ave
	1 MHz	1/T	<98%	Ave

Note: T is minimum transmission duration

7.4 Test Procedure

Maximizing procedure was performed on the highest emissions to ensure that the EUT complied with all installation combinations.

All data was recorded in the Quasi-peak detector mode from 30 MHz to 1 GHz and PK and average detector modes for frequencies above 1 GHz.

7.5 Corrected Factor & Margin Calculation

The Correct Factor is calculated by adding the Antenna Factor and Cable Loss, and subtracting the Amplifier Gain from the Meter Reading. The basic equation is as follows:

$$\text{Correct Factor} = \text{Antenna Factor} + \text{Cable Loss} - \text{Amplifier Gain}$$

The “Margin” column of the following data tables indicates the degree of compliance with the applicable limit. For example, a margin of -7 dB means the emission is 7 dB below the limit. The equation for margin calculation is as follows:

$$\text{Margin} = \text{Level} - \text{Limit}$$

7.6 Test Results

Test Mode: Transmitting

(Pre-scan with three orthogonal axis, and worse case as Z axis.)

9kHz-30MHz:

(Worst case is SRD mode high channel)

(Pre-scan using three directional polarities, worst case as parallel.)

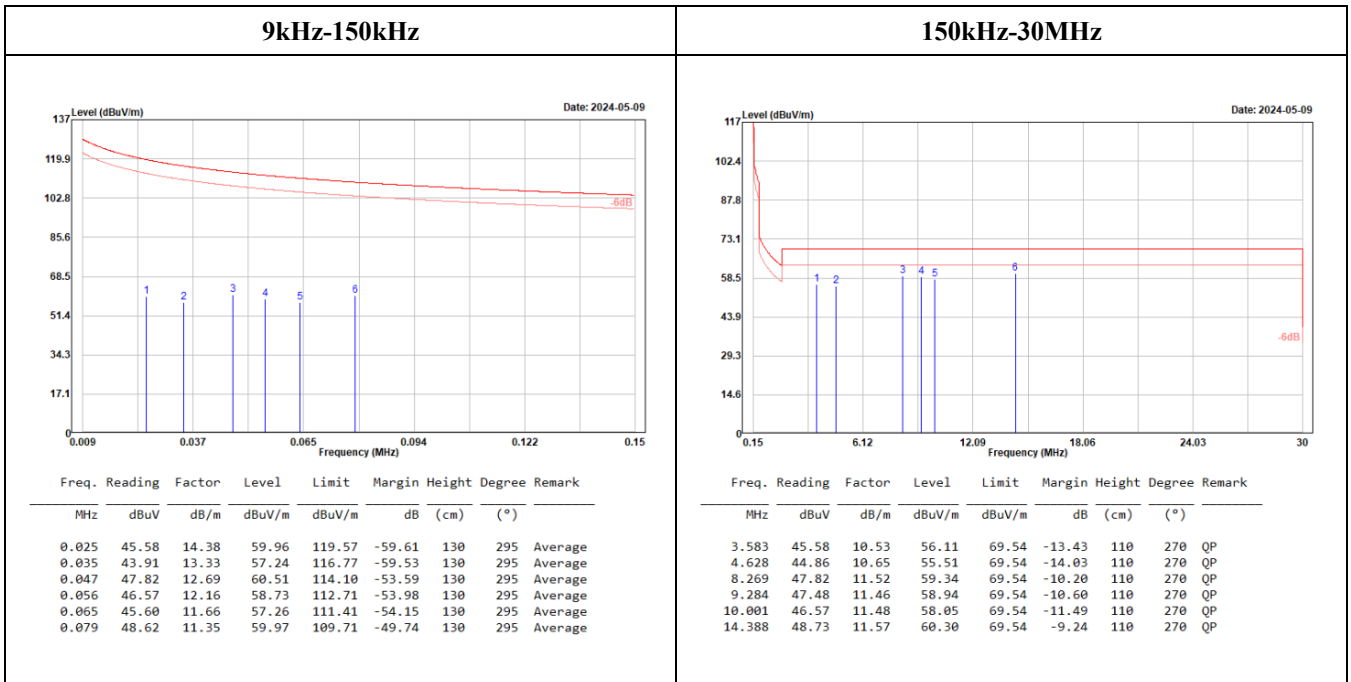

30MHz-1GHz:

(Worst case is SRD mode high channel)

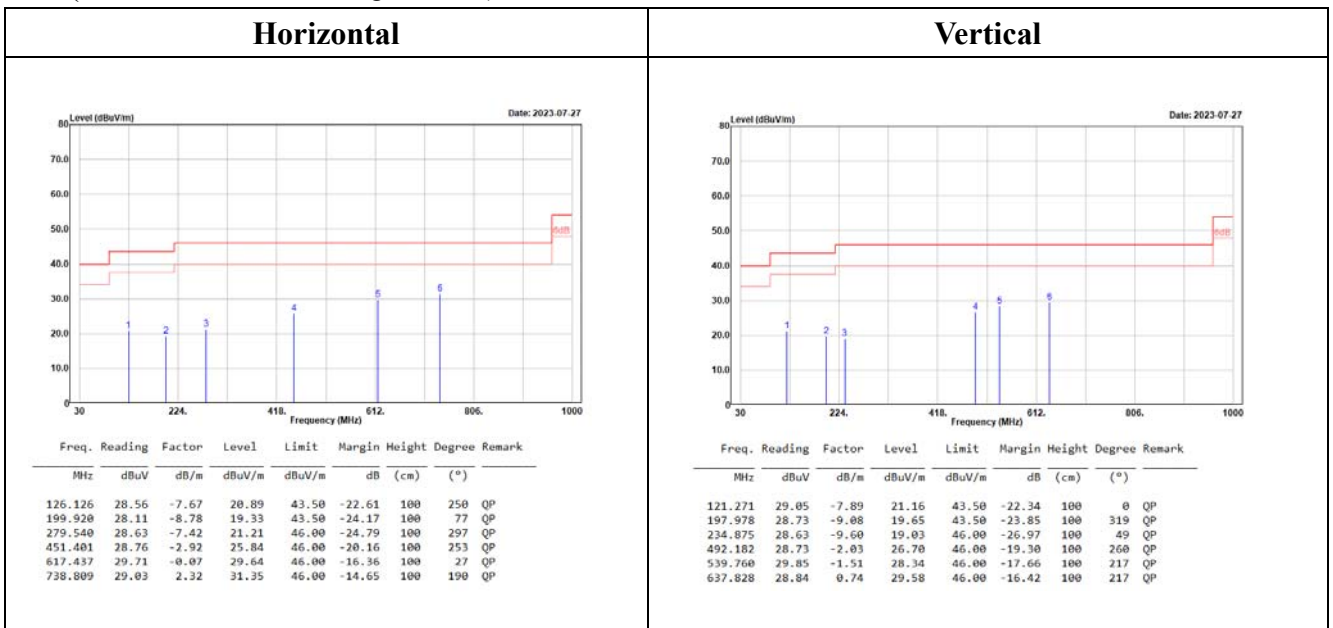

Band-Edge:

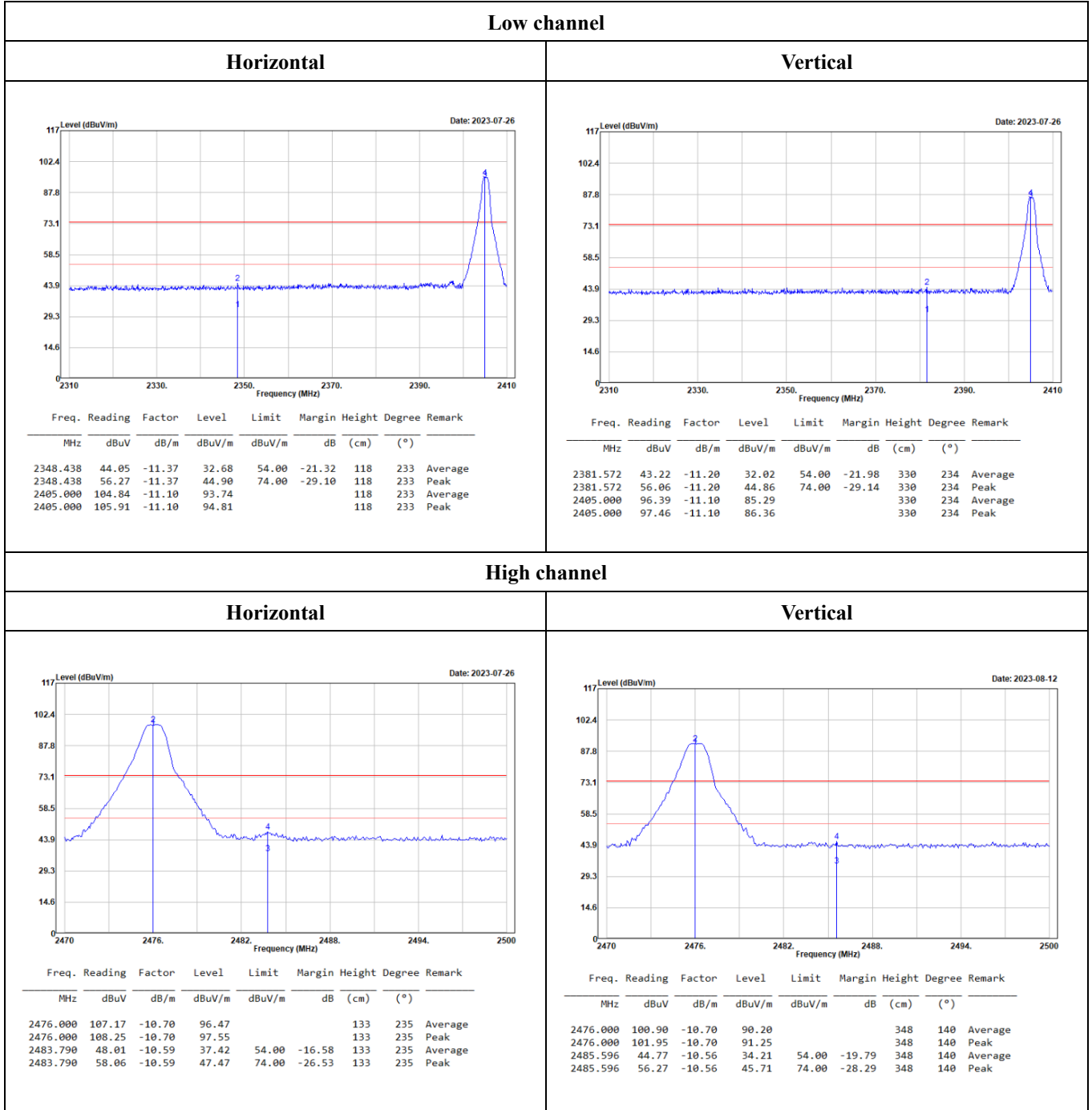

Level = Reading + Factor.

Margin = Level - Limit.

Factor = Antenna Factor + Cable Loss - Amplifier Gain.

(Worst case is SRD mode high channel)

1GHz-18GHz:

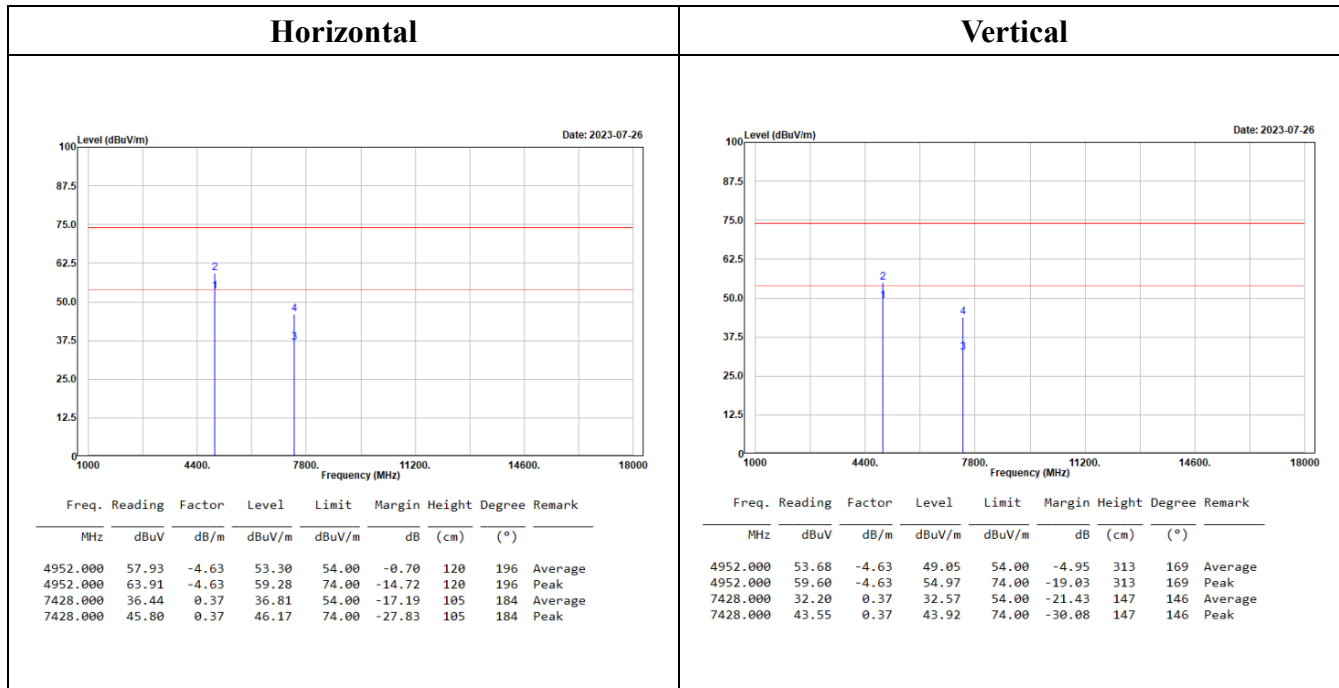

Level = Reading + Factor.

Margin = Level - Limit.

Factor = Antenna Factor + Cable Loss - Amplifier Gain.

18GHz-26.5GHz:

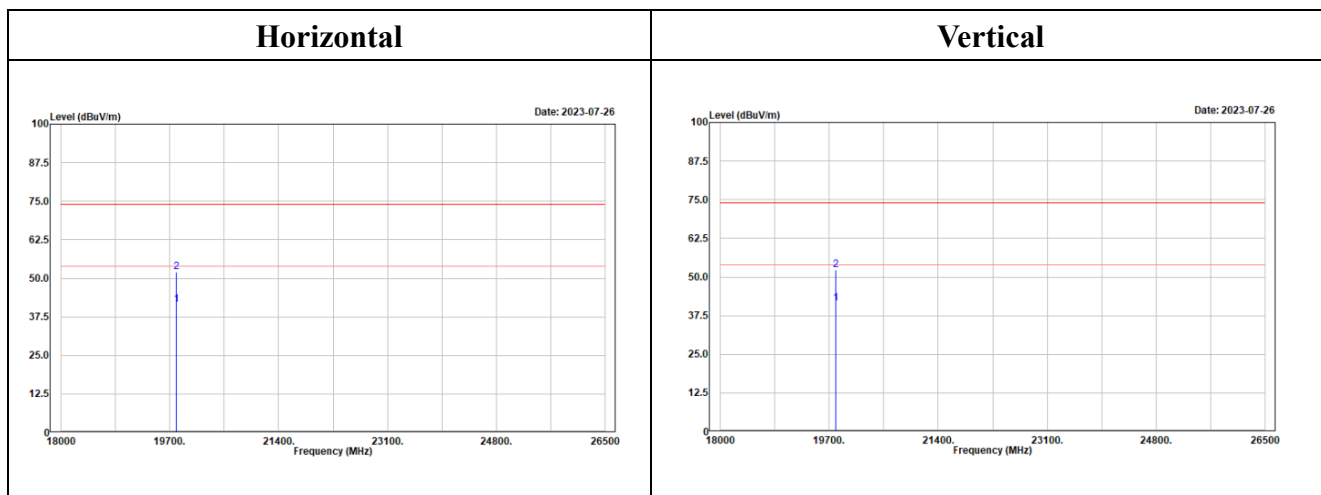

Above 1GHz

Low channel																	
Horizontal								Vertical									
Freq.	Reading	Factor	Level	Limit	Margin	Height	Degree	Remark	Freq.	Reading	Factor	Level	Limit	Margin	Height	Degree	Remark
MHz	dBuV	dB/m	dBuV/m	dBuV/m	dB	(cm)	(°)		MHz	dBuV	dB/m	dBuV/m	dBuV/m	dB	(cm)	(°)	
2348.438	44.05	-11.37	32.68	54.00	-21.32	118	233	Average	2381.572	43.22	-11.20	32.02	54.00	-21.98	330	234	Average
2348.438	56.27	-11.37	44.90	74.00	-29.10	118	233	Peak	2381.572	56.06	-11.20	44.86	74.00	-29.14	330	234	Peak
2405.000	104.84	-11.10	93.74			118	233	Average	2405.000	96.39	-11.10	85.29			330	234	Average
2405.000	105.91	-11.10	94.81			118	233	Peak	2405.000	97.46	-11.10	86.36			330	234	Peak
Freq. Reading Factor Level Limit Margin Height Degree Remark								Freq. Reading Factor Level Limit Margin Height Degree Remark									
MHz dBuV dB/m dBuV/m dBuV/m dB (cm) (°)								MHz dBuV dB/m dBuV/m dBuV/m dB (cm) (°)									
4810.000	57.31	-4.97	52.34	54.00	-1.66	135	202	Average	4810.000	54.22	-4.97	49.25	54.00	-4.75	298	173	Average
4810.000	62.72	-4.97	57.75	74.00	-16.25	135	202	Peak	4810.000	59.51	-4.97	54.54	74.00	-19.46	298	173	Peak
7215.000	42.26	0.02	42.28	54.00	-11.72	110	192	Average	7215.000	35.46	0.02	35.48	54.00	-18.52	271	166	Average
7215.000	48.46	0.02	48.48	74.00	-25.52	110	192	Peak	7215.000	45.43	0.02	45.45	74.00	-28.55	271	166	Peak

Middle channel																	
Horizontal								Vertical									
Freq.	Reading	Factor	Level	Limit	Margin	Height	Degree	Remark	Freq.	Reading	Factor	Level	Limit	Margin	Height	Degree	Remark
MHz	dBuV	dB/m	dBuV/m	dBuV/m	dB	(cm)	(°)		MHz	dBuV	dB/m	dBuV/m	dBuV/m	dB	(cm)	(°)	
2447.000	101.73	-11.05	90.68			112	238	Average	2447.000	91.14	-11.05	80.09			317	53	Average
2447.000	102.83	-11.05	91.78			112	238	Peak	2447.000	92.27	-11.05	81.22			317	53	Peak
Freq. Reading Factor Level Limit Margin Height Degree Remark								Freq. Reading Factor Level Limit Margin Height Degree Remark									
MHz dBuV dB/m dBuV/m dBuV/m dB (cm) (°)								MHz dBuV dB/m dBuV/m dBuV/m dB (cm) (°)									
4894.000	56.32	-4.87	51.45	54.00	-2.55	101	195	Average	4894.000	53.37	-4.87	48.50	54.00	-5.50	281	162	Average
4894.000	62.68	-4.87	57.81	74.00	-16.19	101	195	Peak	4894.000	59.73	-4.87	54.86	74.00	-19.14	281	162	Peak
7341.000	37.79	0.12	37.91	54.00	-16.09	112	183	Average	7341.000	32.77	0.12	32.89	54.00	-21.11	148	296	Average
7341.000	46.76	0.12	46.88	74.00	-27.12	112	183	Peak	7341.000	44.13	0.12	44.25	74.00	-29.75	148	296	Peak

High channel																	
Horizontal								Vertical									
Freq.	Reading	Factor	Level	Limit	Margin	Height	Degree	Remark	Freq.	Reading	Factor	Level	Limit	Margin	Height	Degree	Remark
MHz	dBuV	dB/m	dBuV/m	dBuV/m	dB	(cm)	(°)		MHz	dBuV	dB/m	dBuV/m	dBuV/m	dB	(cm)	(°)	
2476.000	107.17	-10.70	96.47			133	235	Average	2476.000	100.90	-10.70	90.20			348	140	Average
2476.000	108.25	-10.70	97.55			133	235	Peak	2476.000	101.95	-10.70	91.25			348	140	Peak
2483.790	48.01	-10.59	37.42	54.00	-16.58	133	235	Average	2485.596	44.77	-10.56	34.21	54.00	-19.79	348	140	Average
2483.790	58.06	-10.59	47.47	74.00	-26.53	133	235	Peak	2485.596	56.27	-10.56	45.71	74.00	-28.29	348	140	Peak
Freq. Reading Factor Level Limit Margin Height Degree Remark								Freq. Reading Factor Level Limit Margin Height Degree Remark									
MHz dBuV dB/m dBuV/m dBuV/m dB (cm) (°)								MHz dBuV dB/m dBuV/m dBuV/m dB (cm) (°)									
4952.000	57.93	-4.63	53.30	54.00	-0.70	120	196	Average	4952.000	53.68	-4.63	49.05	54.00	-4.95	313	169	Average
4952.000	63.91	-4.63	59.28	74.00	-14.72	120	196	Peak	4952.000	59.60	-4.63	54.97	74.00	-19.03	313	169	Peak
7428.000	36.44	0.37	36.81	54.00	-17.19	105	184	Average	7428.000	32.20	0.37	32.57	54.00	-21.43	147	146	Average
7428.000	45.80	0.37	46.17	74.00	-27.83	105	184	Peak	7428.000	43.55	0.37	43.92	74.00	-30.08	147	146	Peak

Level = Reading + Factor.

Margin = Level - Limit.

Factor = Antenna Factor + Cable Loss - Amplifier Gain.

Conducted Spurious Emissions:

Channel	Frequency (MHz)	Delta Peak to Band Emission (dBc)	Limit (dBc)	Result
Low	2405	34.60	≥ 20	PASS
Mid	2447	31.58	≥ 20	PASS
High	2476	33.81	≥ 20	PASS

**SRD Mode
Low Channel**

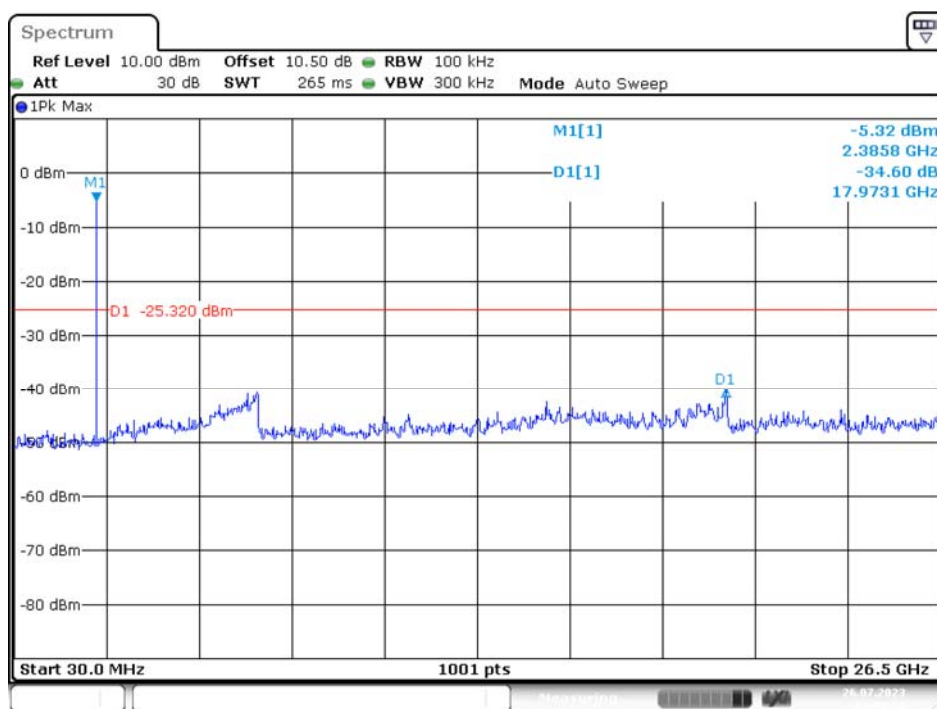

Date: 26 JUL 2023 14:48:26

Middle Channel

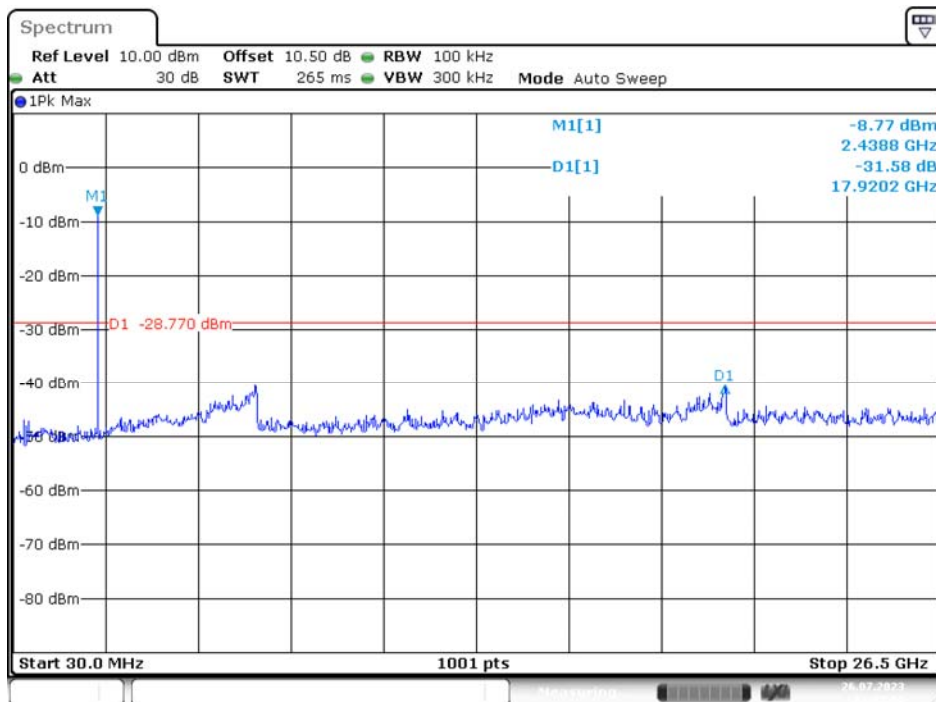

Date: 26 JUL 2023 14:51:01

High Channel

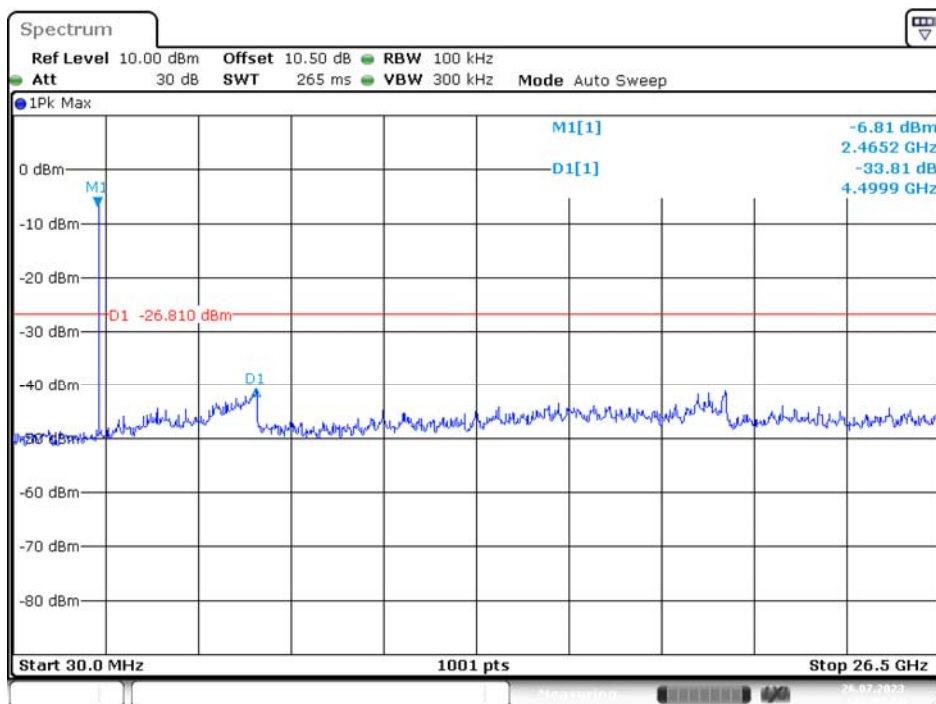

Date: 26 JUL 2023 14:57:17

8 FCC §15.247(a)(2) – 6 dB Emission Bandwidth

8.1 Applicable Standard

According to FCC §15.247(a)(2).

Systems using digital modulation techniques may operate in the 902–928 MHz, 2400–2483.5 MHz, and 5725–5850 MHz bands. The minimum 6 dB bandwidth shall be at least 500 kHz.

8.2 Test Procedure

According to ANSI C63.10-2013, section 11.8

The steps for the first option are as follows:

- a) Set RBW = 100 kHz.
- b) Set the VBW $\geq [3 \times \text{RBW}]$.
- c) Detector = peak.
- d) Trace mode = max hold.
- e) Sweep = auto couple.
- f) Allow the trace to stabilize.
- g) Measure the maximum width of the emission that is constrained by the frequencies associated with the two outermost amplitude points (upper and lower frequencies) that are attenuated by 6 dB relative to the maximum level measured in the fundamental emission.

8.3 Test Results

Channel	Frequency (MHz)	6 dB Emission Bandwidth (MHz)	Limit (kHz)	Result
Low	2405	0.735	> 500	Compliance
Middle	2447	0.756	> 500	Compliance
High	2476	0.753	> 500	Compliance

Please refer to the following plots

SRD Mode Low Channel

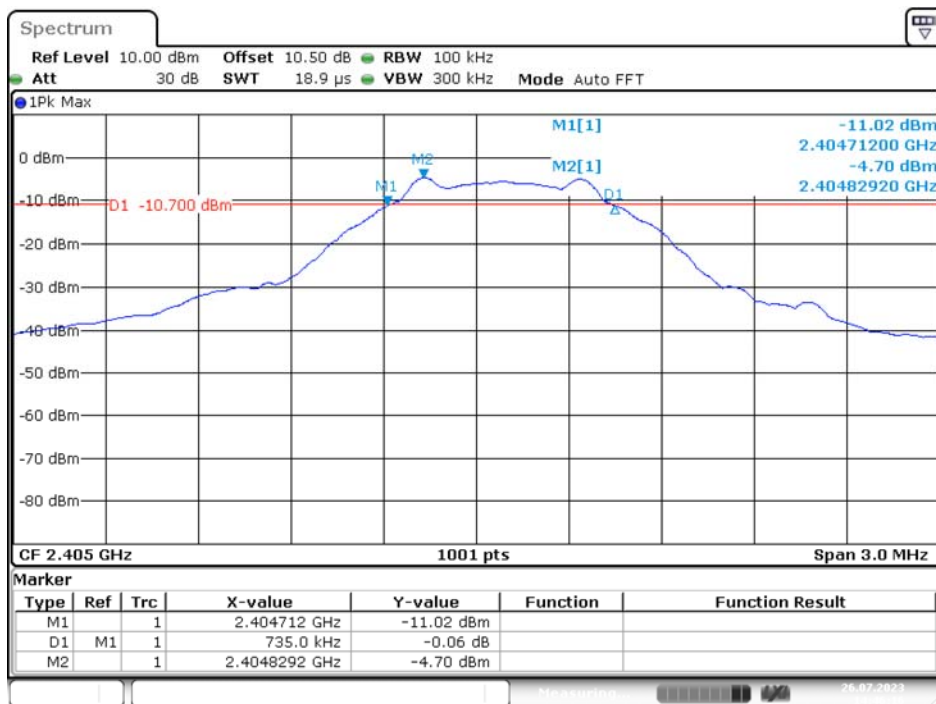

Date: 26 JUL 2023 14:46:17

Middle Channel

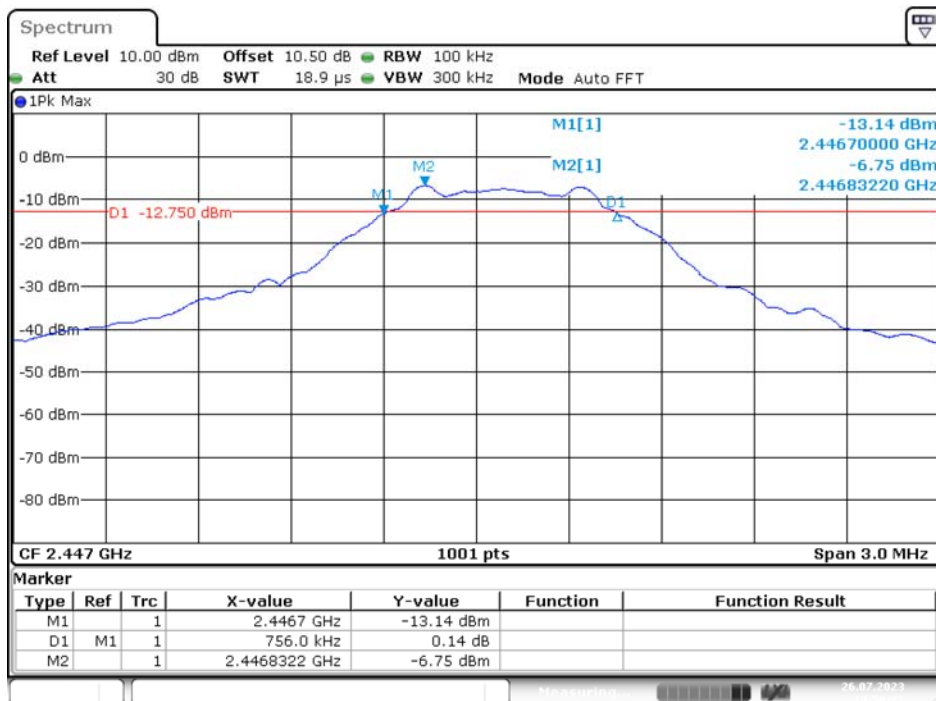

Date: 26 JUL 2023 14:50:21

High Channel

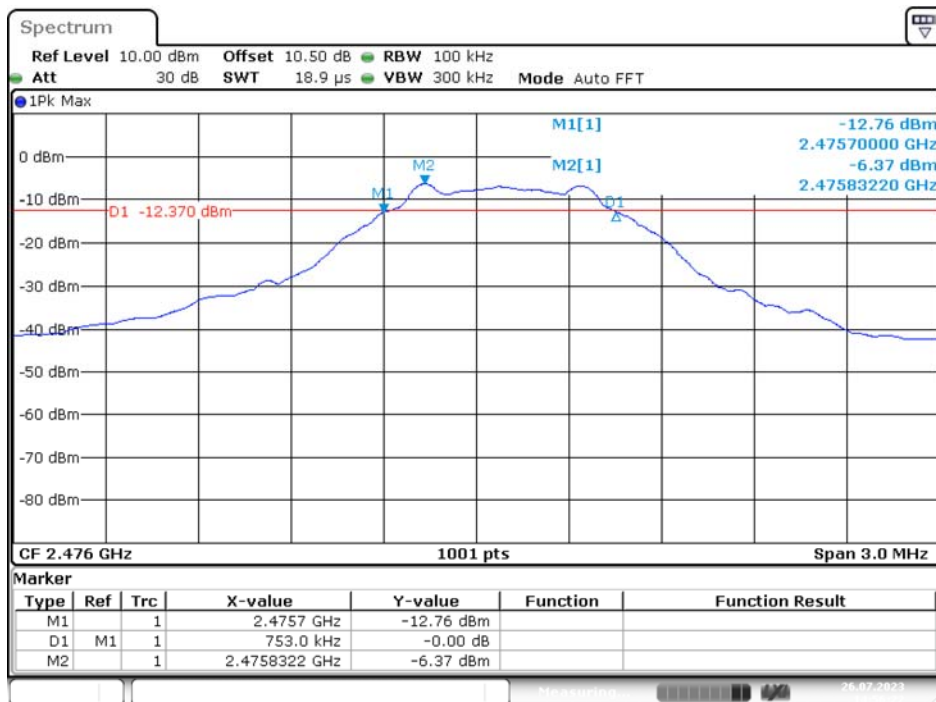

Date: 26. JUL. 2023 14:56:22

9 FCC §15.247(b)(3) – Maximum Output Power

9.1 Applicable Standard

According to FCC §15.247(b) (3).

Systems using digital modulation in the 902-928 MHz, 2400-2483.5 MHz, and 5725-5850 MHz bands: 1 Watt. As an alternative to a peak power measurement, compliance with the one Watt limit can be based on a measurement of the maximum conducted output power. Maximum Conducted Output Power is defined as the total transmit power delivered to all antennas and antenna elements averaged across all symbols in the signaling alphabet when the transmitter is operating at its maximum power control level. Power must be summed across all antennas and antenna elements. The average must not include any time intervals during which the transmitter is off or is transmitting at a reduced power level. If multiple modes of operation are possible (e.g., alternative modulation methods), the maximum conducted output power is the highest total transmit power occurring in any mode.

9.2 Test Procedure

According to ANSI C63.10-2013, section 11.9.1.3

1. Place the EUT on a bench and set it in transmitting mode.
2. Remove the antenna from the EUT and then connect a low loss RF cable from the antenna port to measuring equipment.

9.3 Test Results

Conducted Peak Output Power

Channel	Frequency (MHz)	Conducted Peak Output Power (dBm)	Power (W)	Limit (W)	Result
SRD Mode					
Low	2405	-1.81	0.0007	1	PASS
Middle	2447	-4.12	0.0004	1	PASS
High	2476	-4.20	0.0004	1	PASS

10 FCC§15.247(d) – 100 kHz Bandwidth of Frequency Band Edge

10.1 Applicable Standard

According to FCC §15.247(d).

In any 100 kHz bandwidth outside the frequency band in which the spread spectrum or digitally modulated intentional radiator is operating, the radio frequency power that is produced by the intentional radiator shall be at least 20 dB below that in the 100 kHz bandwidth within the band that contains the highest level of the desired power, based on either an RF conducted or a radiated measurement, provided the transmitter demonstrates compliance with the peak conducted power limits. If the transmitter complies with the conducted power limits based on the use of RMS averaging over a time interval, as permitted under paragraph (b)(3) of this section, the attenuation required under this paragraph shall be 30 dB instead of 20 dB. Attenuation below the general limits specified in §15.209(a) is not required. In addition, radiated emissions which fall in the restricted bands, as defined in §15.205(a), must also comply with the radiated emission limits specified in §15.209(a) (see §15.205(c)).

10.2 Test Procedure

According to ANSI C63.10-2013 Section 11.11

1. Check the calibration of the measuring instrument using either an internal calibrator or a known signal from an external generator.
2. Position the EUT without connection to measurement instrument. Turn on the EUT and connect its antenna terminal to measurement instrument via a low loss cable. Then set it to any one measured frequency within its operating range, and make sure the instrument is operated in its linear range.
3. Set RBW to 100 kHz and VBW of spectrum analyzer to 300 kHz with a convenient frequency span including 100 kHz bandwidth from band edge.
4. Measure the highest amplitude appearing on spectral display and set it as a reference level. Plot the graph with marking the highest point and edge frequency.
5. Repeat above procedures until all measured frequencies were complete.

10.3 Test Results

Channel	Frequency (MHz)	Delta Peak to Band Emission (dBc)	Limit (dBc)	Result
Low	2405	44.52	≥ 20	PASS
High	2476	40.79	≥ 20	PASS

Please refer to the following plots

SRD Mode Band Edge, Left Side

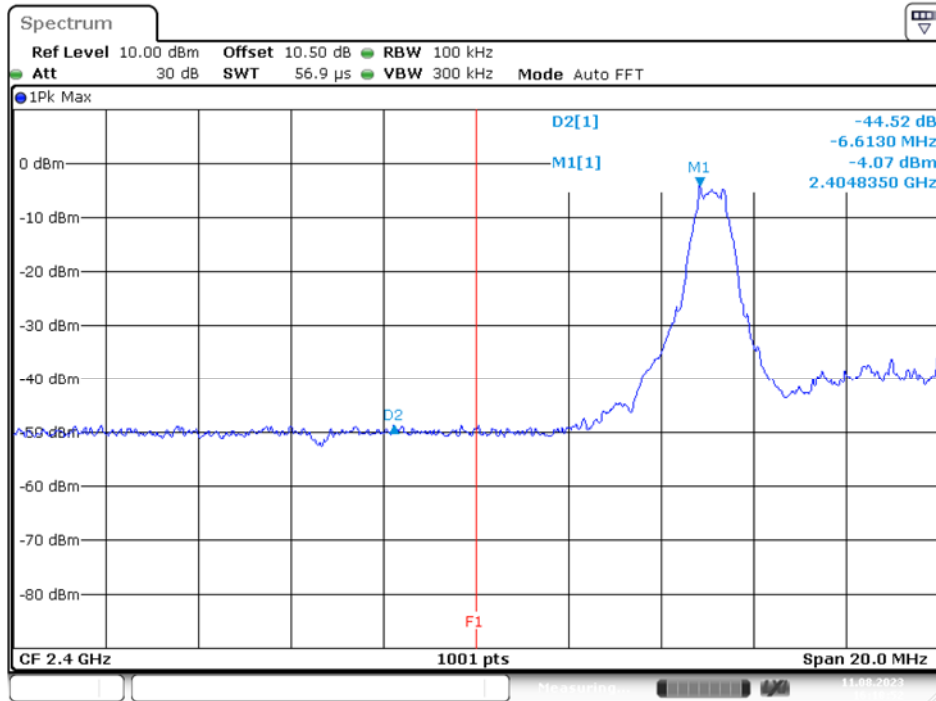

Date: 26 JUL 2023 14:48:11

Band Edge, Right Side

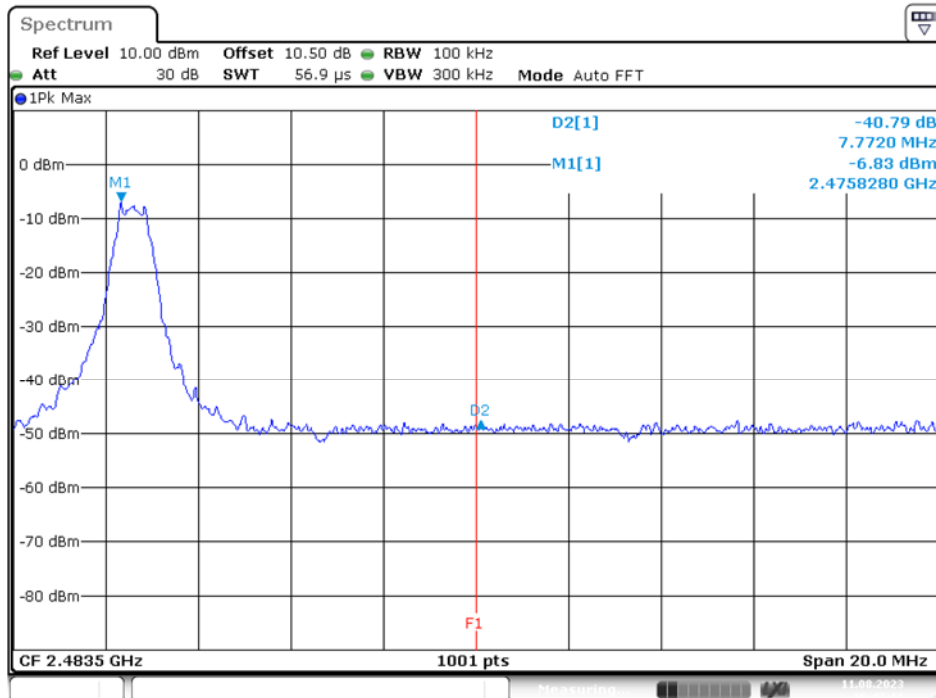

Date: 26 JUL 2023 14:57:02

11 FCC §15.247(e) – Power Spectral Density

11.1 Applicable Standard

According to FCC §15.247(e).

For digitally modulated systems, the power spectral density conducted from the intentional radiator to the antenna shall not be greater than 8 dBm in any 3 kHz band during any time interval of continuous transmission. This power spectral density shall be determined in accordance with the provisions of paragraph (b) of this section. The same method of determining the conducted output power shall be used to determine the power spectral density.

11.2 Test Procedure

According to ANSI C63.10-2013, section 11.10.2

- a) Set analyzer center frequency to DTS channel center frequency.
- b) Set the span to 1.5 times the DTS bandwidth.
- c) Set the RBW to $3 \text{ kHz} \leq \text{RBW} \leq 100 \text{ kHz}$.
- d) Set the VBW $\geq [3 \times \text{RBW}]$.
- e) Detector = peak.
- f) Sweep time = auto couple.
- g) Trace mode = max hold.
- h) Allow trace to fully stabilize.
- i) Use the peak marker function to determine the maximum amplitude level within the RBW.
- j) If measured value exceeds requirement, then reduce RBW (but no less than 3 kHz) and repeat

11.3 Test Results

Channel	Frequency (MHz)	Power Spectral Density (dBm/3 kHz)	Limit (dBm/3 kHz)	Result
Low	2405	-19.07	8	Compliance
Middle	2447	-21.09	8	Compliance
High	2476	-20.65	8	Compliance

Please refer to the following plots

SRD Mode Low Channel

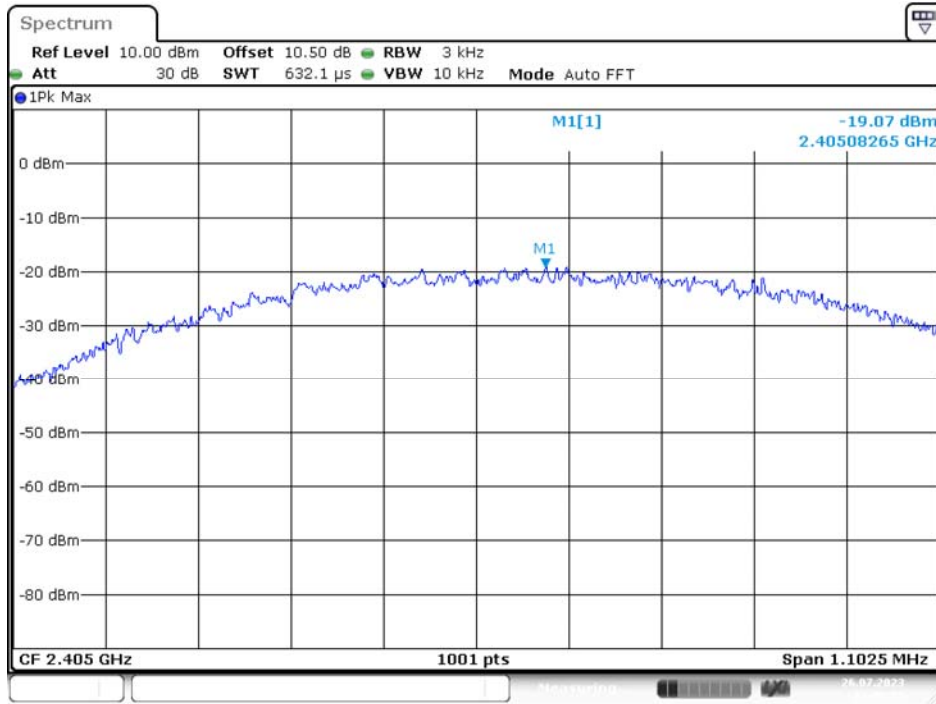

Date: 26. JUL. 2023 14:46:26

Middle Channel

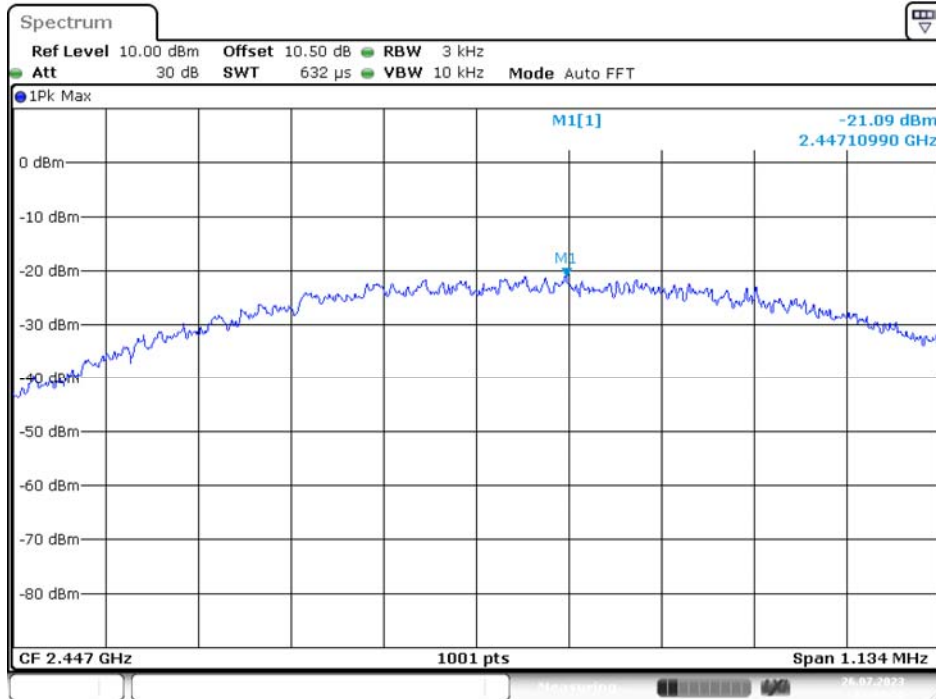

Date: 26. JUL. 2023 14:50:30

High Channel

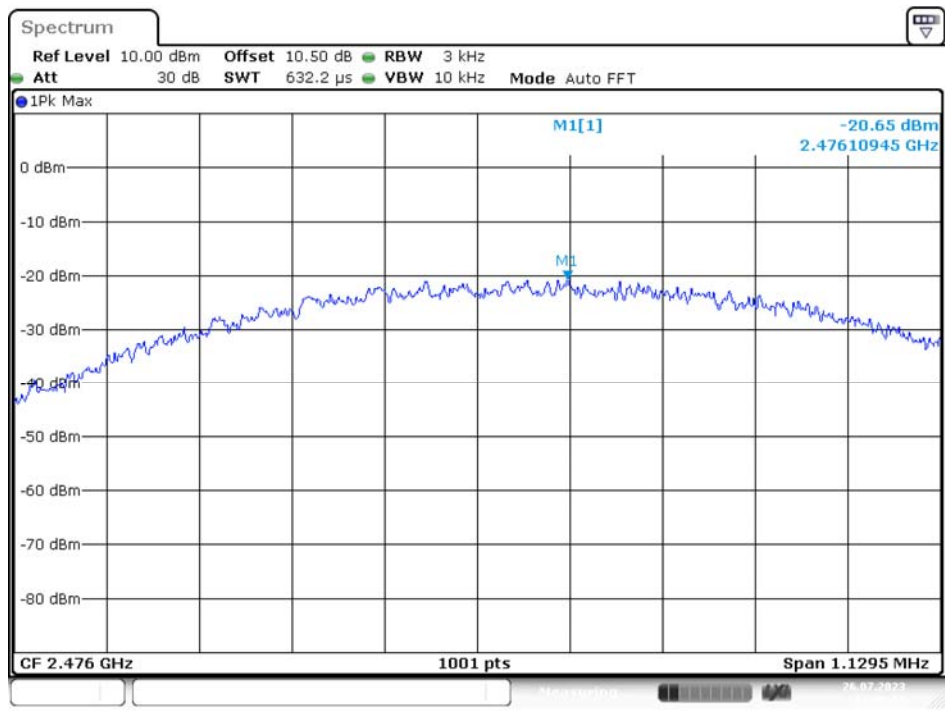

Date: 26 JUL 2023 14:56:31

***** END OF REPORT *****