

RADIO TEST REPORT – REP016954

Type of assessment:

Final product testing

Applicant:

M.A.E. ELETTRONICA S.R.L.

Via Presolana, 3/31 – 24030 Medolago (BG) - Italy

Product:

Dashboard

Model:

RTADM002

Versions

n/a

FCC ID:

2AVGH-RTADM002

IC Registration number:

25794-RTADM002

Specifications:

- ◆ FCC 47 CFR Part 15 Subpart C
- ◆ RSS-210, Issue 10, December 2019, Amendment (April 2020)

Date of issue: **September 25, 2023**

Oscar Frau

Tested by



Signature

Roberto Giampaglia

Reviewed by



Signature

This test report shall not be partially reproduced without the prior written consent of Nemko S.p.A. The phase of sampling of equipment under test is carried out by the customer. Results indicated in this test report refer exclusively to the tested samples and apply to the sample as received. This Test Report, when bearing the Nemko name and logo is only valid when issued by a Nemko laboratory, or by a laboratory having special agreement with Nemko.

Test location

Company name	Nemko Spa
Address	Via del Carroccio, 4
City	Biassono
Province	MB
Postal code	20853
Country	Italy
Telephone	+39 039 220 12 01
Facsimile	+39 039 220 12 21
Website	www.nemko.com
Site number	682159 and 9109A

Limits of responsibility

Note that the results contained in this report relate only to the items tested and were obtained in the period between the date of initial receipt of samples and the date of issue of the report. This test report has been completed in accordance with the requirements of ISO/IEC 17025. All results contain in this report are within Nemko Spa ISO/IEC 17025 accreditation.

Copyright notification

Nemko Spa authorizes the applicant to reproduce this report provided it is reproduced in its entirety and for use by the company's employees only. Any use which a third party makes of this report, or any reliance on or decisions to be made based on it, are the responsibility of such third parties. Nemko Spa accepts no responsibility for damages, if any, suffered by any third party as a result of decisions made or actions based on this report.

Table of contents

Table of contents	3
Section 1. Report summary	4
1.1 Applicant and manufacturer.....	4
1.2 Test specifications.....	4
1.3 Test methods.....	4
1.4 Statement of compliance.....	4
1.5 Exclusions.....	4
1.6 Test report revision history.....	4
Section 2. Summary of test results	5
2.1 FCC Part 15 Subpart C, general requirements test results.....	5
2.2 IC RSS-GEN, Issue 5, test results.....	5
2.3 IC RSS-210, Issue 10, test results.....	5
Section 3. Equipment under test (EUT) details	6
3.1 Sample information.....	6
3.2 EUT information.....	6
3.3 Technical information.....	6
3.4 Product description and theory of operation.....	7
3.5 EUT exercise details.....	7
3.6 EUT setup photos.....	8
3.7 Equipment Used During Test.....	8
Section 4. Engineering considerations	9
4.1 Modifications incorporated in the EUT.....	9
4.2 Technical judgment.....	9
4.3 Deviations from laboratory tests procedures.....	9
Section 5. Test conditions	10
5.1 Atmospheric conditions.....	10
5.2 Power supply range.....	10
Section 6. Measurement uncertainty	11
6.1 Uncertainty of measurement.....	11
Section 7. Test equipment	12
7.1 Test equipment list.....	12
Section 8. Testing data	13
8.1 RSS-Gen 8.11 Frequency stability.....	13
8.2 RSS-Gen 6.7 Occupied bandwidth.....	14
8.3 FCC 15.209(a) and RSS-210, Radiated emissions limits.....	16
Section 9. Block diagrams of test set-ups and EUT photos	24
9.1 Radiated emissions set-up below 30 MHz.....	24
9.2 Radiated emissions set-up below 1 GHz.....	25
9.3 Set-up photos.....	26
9.4 EUT photos.....	29

Section 1. Report summary

1.1 Applicant and manufacturer

Applicant name	M.A.E. ELETTRONICA S.R.L.
Applicant address	Via Presolana, 3/31 – 24030 Medolago (BG) - Italy
Manufacture name	Same as applicant
Manufacture address	Same as applicant

1.2 Test specifications

FCC 47 CFR Part 15, Subpart C	Intentional radiators
RSS-210, Issue 10 , Amendment (April 2020), Section 7	General field strength limits

1.3 Test methods

ANSI C63.10 v2013	American National Standard of Procedures for Compliance Testing of Unlicensed Wireless Devices
RSS-Gen, Issue 5 (April 2018) + Amendment 1 (March 2019) + Amendment 2 (February 2021)	General Requirements for Compliance of Radio Apparatus

1.4 Statement of compliance

In the configuration tested, the EUT was found compliant.

Testing was completed against all relevant requirements of the test standard. Results obtained indicate that the product under test complies in full with the requirements tested. The test results relate only to the items tested.

See "Summary of test results" for full details.

1.5 Exclusions

None

1.6 Test report revision history

Revision #	Details of changes made to test report
REP016954	Original report issued

Section 2. Summary of test results

2.1 FCC Part 15 Subpart C, general requirements test results

Part	Test description	Verdict
§15.207(a)	Conducted limits	Not applicable ¹
§15.31	Variation of power source	Pass ²
§15.31(m)	Number of tested frequencies	Pass ³
§15.203	Antenna requirement	Pass ⁴
§15.209	Radiated emission limits; general requirements.	Pass

Notes: ¹ The EUT is supplied by the vehicle battery.

² Measurements of the variation of the input power or the radiated signal level of the fundamental frequency component of the emission, as appropriate, was performed with the supply voltage varied between 85 % and 115 % of the nominal rated supply voltage. No noticeable output power variation was observed.

³ The EUT use only one transmitting frequency

⁴ The Antennas are located within the enclosure of EUT and not user accessible.

2.2 IC RSS-GEN, Issue 5, test results

Part	Test description	Verdict
6.7	Occupied bandwidth	Pass
8.8	AC power lines conducted emission limits	Not applicable ¹
8.9	Transmitter emission limits	Pass
8.11	Transmitter frequency stability	Pass

Notes: ¹ The EUT is supplied by the vehicle battery.

² The EUT does not have a stand-alone receiver neither scanner receiver, therefore exempt from receiver requirements.

2.3 IC RSS-210, Issue 10, test results

Part	Test description	Verdict
7.2	General field strength limits	Pass
7.3	Transmitters with Wanted Emissions that are Within the General Field Strength Limits	Pass

Notes: None

Section 3. Equipment under test (EUT) details

3.1 Sample information

Receipt date	July 21, 2023
Nemko sample ID number	00185000025

3.2 EUT information

Product name	Dashboard
Model	RTADM002
Model version	--
Serial number	40611981C

3.3 Technical information

Operating frequency	134.2 kHz
Modulation type	FSK
Field strength, dB μ V/m @ 10 m	73.57
Occupied bandwidth (99 %)	9.85 kHz
Transmitted spurious emission, dB μ V/m @ 3 m	27.8 @346.4800MHz
Emission designator	F1D
Power requirements	14.5 Vdc from vehicular battery
Antenna information	The EUT uses a unique antenna coupling/ non-detachable antenna to the intentional radiator. Loop antenna, type EL017601_0, made by ZADI S.p.A.

3.4 Product description and theory of operation

The EUT is a motorcycle dashboard. It is able to drive directly some loads presents on the bike (high & low beam, claxon), and with CAN line it is able to send and receive data from/to other devices joined to the line. The EUT is provided with an immobilizer system working at 134 kHz.

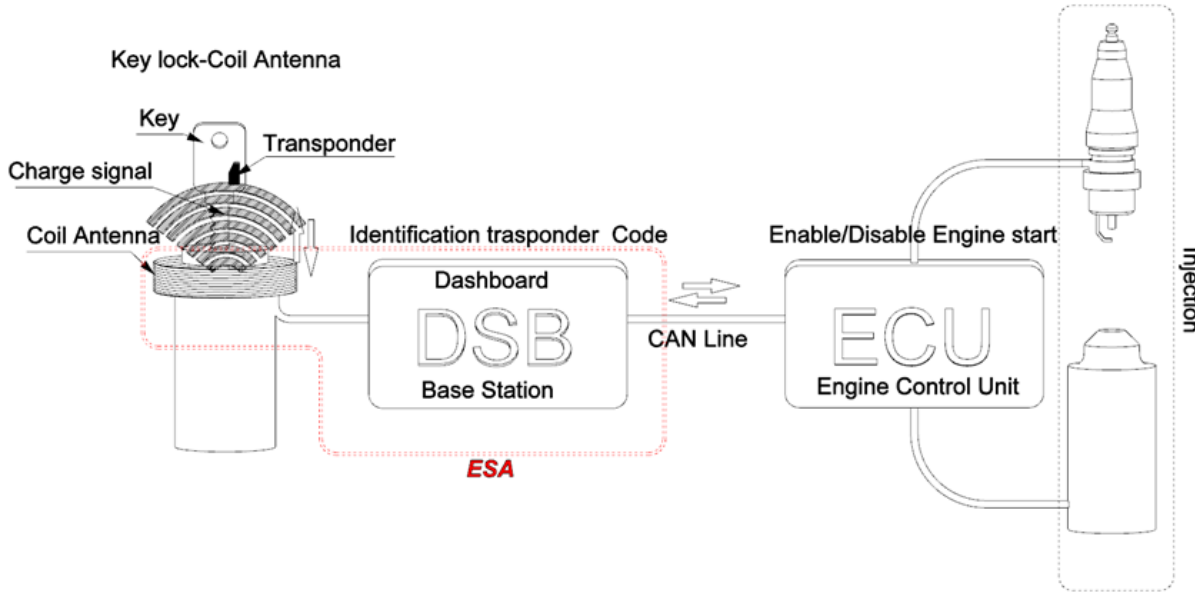

3.5 EUT exercise details

The EUT has been tested forced in continuous transmission mode by a dedicated firmware preinstalled by the manufacturer. Firmware version: 08.04

3.6 EUT setup photos



Figure 3.6-1: Setup photos

3.7 Equipment Used During Test

Table 3.7-1: Equipment Used During Test

Description	Brand name	Model/Part number	Serial number
Original cable and accessories	Ducati	--	--
ECU	Ducati	--	--
TEST BENCH	Ducati	DSB V21D	--
LIN	Ducati	--	--

Section 4. Engineering considerations

4.1 Modifications incorporated in the EUT

There were no modifications performed to the EUT during this assessment.

4.2 Technical judgment

None

4.3 Deviations from laboratory tests procedures

No deviations were made from laboratory procedures.

Section 5. Test conditions

5.1 Atmospheric conditions

Temperature	15 °C – 35 °C
Relative humidity	20 % – 75 %
Air pressure	86 kPa (860 mbar) – 106 kPa (1060 mbar)

When it is impracticable to carry out tests under these conditions, a note to this effect stating the ambient temperature and relative humidity during the tests shall be recorded and stated.

The following instruments are used to monitor the environmental conditions:

Equipment	Manufacturer	Model no.	Asset no.	Cal date	Next cal.
Thermo-hygrometer data loggers	Testo	175-H2	20012380/305	2022-12	2024-12
Thermo-hygrometer data loggers	Testo	175-H2	38203337/703	2022-12	2024-12
Barometer	Castle	GPB 3300	072015	2023-04	2024-04

5.2 Power supply range

The normal test voltage for equipment to be connected to the mains shall be the nominal mains voltage. For the purpose of the present document, the nominal voltage shall be the declared voltage, or any of the declared voltages $\pm 15\%$, for which the equipment was designed.

Section 6. Measurement uncertainty

6.1 Uncertainty of measurement

The measurement uncertainty was calculated for each test and quantity listed in this test report, according to CISPR 16-4-2 and other specific test standard and is documented in Nemko Spa working manual WML1002.

The assessment of conformity for each test performed on the equipment is performed not taking into account the measurement uncertainty. The two following possible verdicts are stated in the report:

P (Pass) - The measured values of the equipment respect the specification limit at the points tested. The specific risk of false accept is up to 50% when the measured result is close to the limit.

F (Fail) - One or more measured values of the equipment do not respect the specification limit at the points tested. The specific risk of false reject is up to 50% when the measured result is close to the limit.

Hereafter Nemko's measurement uncertainties are reported:

EUT	Type	Test	Range	Measurement Uncertainty	Notes
Transmitter	Conducted	Frequency error	0.001 MHz ÷ 40 GHz	0.08 ppm	(1)
		Carrier power RF Output Power	0.009 MHz ÷ 30 MHz	1.1 dB	(1)
			30 MHz ÷ 18 GHz	1.5 dB	(1)
			18 MHz ÷ 40 GHz	3.0 dB	(1)
			40 MHz ÷ 140 GHz	5.0 dB	(1)
		Adjacent channel power	1 MHz ÷ 18 GHz	1.4 dB	(1)
		Conducted spurious emissions	0.009 MHz ÷ 18 GHz	3.0 dB	(1)
			18 GHz ÷ 40 GHz	4.2 dB	(1)
			40 GHz ÷ 220 GHz	6.0 dB	(1)
		Intermodulation attenuation	1 MHz ÷ 18 GHz	2.2 dB	(1)
		Attack time – frequency behaviour	1 MHz ÷ 18 GHz	2.0 ms	(1)
		Attack time – power behaviour	1 MHz ÷ 18 GHz	2.5 ms	(1)
		Release time – frequency behaviour	1 MHz ÷ 18 GHz	2.0 ms	(1)
		Release time – power behaviour	1 MHz ÷ 18 GHz	2.5 ms	(1)
		Transient behaviour of the transmitter– Transient frequency behaviour	1 MHz ÷ 18 GHz	0.2 kHz	(1)
		Transient behaviour of the transmitter – Power level slope	1 MHz ÷ 18 GHz	9%	(1)
		Frequency deviation - Maximum permissible frequency deviation	0.001 MHz ÷ 18 GHz	1.3%	(1)
		Frequency deviation - Response of the transmitter to modulation frequencies above 3 kHz	0.001 MHz ÷ 18 GHz	0.5 dB	(1)
		Dwell time	-	3%	(1)
	Hopping Frequency Separation	0.01 MHz ÷ 18 GHz	1%	(1)	
	Occupied Channel Bandwidth	0.01 MHz ÷ 18 GHz	2%	(1)	
	Modulation Bandwidth	0.01 MHz ÷ 18 GHz	2%	(1)	
	Radiated	Radiated spurious emissions	0.009 MHz ÷ 26.5 GHz	6.0 dB	(1)
26.5 GHz ÷ 66 GHz			8.0 dB	(1)	
66 GHz ÷ 220 GHz			10 dB	(1)	
Effective radiated power transmitter		10 kHz ÷ 26.5 GHz	6.0 dB	(1)	
		26.5 GHz ÷ 66 GHz	8.0 dB	(1)	
66 GHz ÷ 220 GHz	10 dB	(1)			

NOTES:

(1) The reported expanded uncertainty of measurement is stated as the standard uncertainty of measurement multiplied by the coverage factor $k = 2$, which for a normal distribution corresponds to a coverage probability of approximately 95 %

Section 7. Test equipment

7.1 Test equipment list

Table 7.1-1: Equipment list

Equipment	Manufacturer	Model no.	Asset no.	Cal cycle	Next cal.
EMI Receiver	Rohde & Schwarz	ESW44	101620	2023-08	2024-08
EMI Receiver	Rohde & Schwarz	ESU8	100202	2022-09	2023-09
Antenna Loop Attiva	Teseq	HLA6121+PI6121	45749	2023-07	2026-07
Antenna Trilog 25MHz - 8GHz	Schwarzbeck Mess-Elektronik	VULB9162	9162-025	2021-07	2024-07
Controller	Maturo	FCU3.0	10041	NCR	NCR
Tilt antenna mast	Maturo	TAM4.0-E	10042	NCR	NCR
Turntable	Maturo	TT4.0-5T	2.527	NCR	NCR
Semi-anechoic chamber	Nemko S.p.a.	10m semi-anechoic chamber	530	2021-09	2023-09
Climatic Chamber	MSL	EC500DA	15022	2023-02	2024-02

Notes: NCR - no calibration required, VOU - verify on use

Section 8. Testing data

8.1 RSS-Gen 8.11 Frequency stability

8.1.1 Definitions and limits

If the frequency stability of the licence-exempt radio apparatus is not specified in the applicable RSS, the fundamental emissions of the radio apparatus should be kept within at least the central 80% of its permitted operating frequency band in order to minimize the possibility of out-of-band operation. In addition, its occupied bandwidth shall be entirely outside the restricted bands and the prohibited TV bands of 54-72 MHz, 76-88 MHz, 174-216 MHz, and 470-602 MHz, unless otherwise indicated.

8.1.2 Test summary

Verdict	Pass		
Tested by	Oscar Frau	Test date	September 15, 2023

8.1.3 Observations, settings and special notes

Spectrum analyzer settings:

Detector mode	Peak
Resolution bandwidth	≥1 % of emission bandwidth
Video bandwidth	RBW × 3
Trace mode	Max Hold

8.1.4 Test equipment used

Equipment	Manufacturer	Model no.	Asset no.
EMI Receiver	Rohde & Schwarz	ESW44	101620
Climatic Chamber	MSL	EC500DA	15022

8.1.5 Test data

Test conditions	Frequency, kHz	Frequency drift, ±ppm	Limit, ±ppm	Margin, ppm
+50 °C, Nominal	134.448717949	-77.5	--	--
+40 °C, Nominal	134.450745652	-62.4	--	--
+30 °C, Nominal	134.455372156	-28.0	--	--
+20 °C, +15 %	134.459134615	0.0	--	--
+20 °C, Nominal	134.459134615	Reference	Reference	Reference
+20 °C, -15 %	134.459134615	0.0	--	--
+10 °C, Nominal	134.462355314	24.0	--	--
-0 °C, Nominal	134.465544872	47.7	--	--
-10 °C, Nominal	134.467147436	59.6	--	--
-20 °C, Nominal	134.471942308	95.3	--	--

Note: frequency drift was calculated as follows:

$$\text{Frequency drift (ppm)} = ((F_{\text{measured}} - F_{\text{reference}}) \div F_{\text{reference}}) \times 1 \times 10^6$$

8.2 RSS-Gen 6.7 Occupied bandwidth

8.2.1 Definitions and limits

The occupied bandwidth or the “99% emission bandwidth” is defined as the frequency range between two points, one above and the other below the carrier frequency, within which 99% of the total transmitted power of the fundamental transmitted emission is contained. The occupied bandwidth shall be reported for all equipment in addition to the specified bandwidth required in the applicable RSSs.

The following conditions shall be observed for measuring the occupied bandwidth:

The transmitter shall be operated at its maximum carrier power measured under normal test conditions.

The span of the spectrum analyzer shall be set large enough to capture all products of the modulation process, including the emission skirts, around the carrier frequency, but small enough to avoid having other emissions (e.g. on adjacent channels) within the span.

The detector of the spectrum analyzer shall be set to “Sample”. However, a peak, or peak hold, may be used in place of the sampling detector since this usually produces a wider bandwidth than the actual bandwidth (worst-case measurement). Use of a peak hold (or “Max Hold”) may be necessary to determine the occupied / x dB bandwidth if the device is not transmitting continuously.

The resolution bandwidth (RBW) shall be in the range of 1% to 5% of the actual occupied / x dB bandwidth and the video bandwidth (VBW) shall not be smaller than three times the RBW value. Video averaging is not permitted.

Note: It may be necessary to repeat the measurement a few times until the RBW and VBW are in compliance with the above requirement.

For the 99% emission bandwidth, the trace data points are recovered and directly summed in linear power level terms. The recovered amplitude data points, beginning at the lowest frequency, are placed in a running sum until 0.5% of the total is reached, and that frequency recorded. The process is repeated for the highest frequency data points (starting at the highest frequency, at the right side of the span, and going down in frequency). This frequency is then recorded. The difference between the two recorded frequencies is the occupied bandwidth (or the 99% emission bandwidth).

8.2.2 Test summary

Verdict	Pass		
Tested by	Oscar Frau	Tested by	Oscar Frau

8.2.3 Observations, settings and special notes

Spectrum analyser settings:

Resolution bandwidth:	1% to 5% of the actual occupied
Video bandwidth:	$\geq 3 \times \text{RBW}$
Detector mode:	Peak
Trace mode:	Max Hold

8.2.4 Test equipment used

Equipment	Manufacturer	Model no.	Asset no.
EMI Receiver	Rohde & Schwarz	ESW44	101620
Antenna Loop Attiva+Power Inserter	Teseq	HLA6121+PI6121	45749
Controller	Maturo	FCU3.0	10041
Tilt antenna mast	Maturo	TAM4.0-E	10042
Turntable	Maturo	TT4.0-5T	2.527
Semi-anechoic chamber	Nemko S.p.a.	10m semi-anechoic chamber	530

8.2.5 Test data

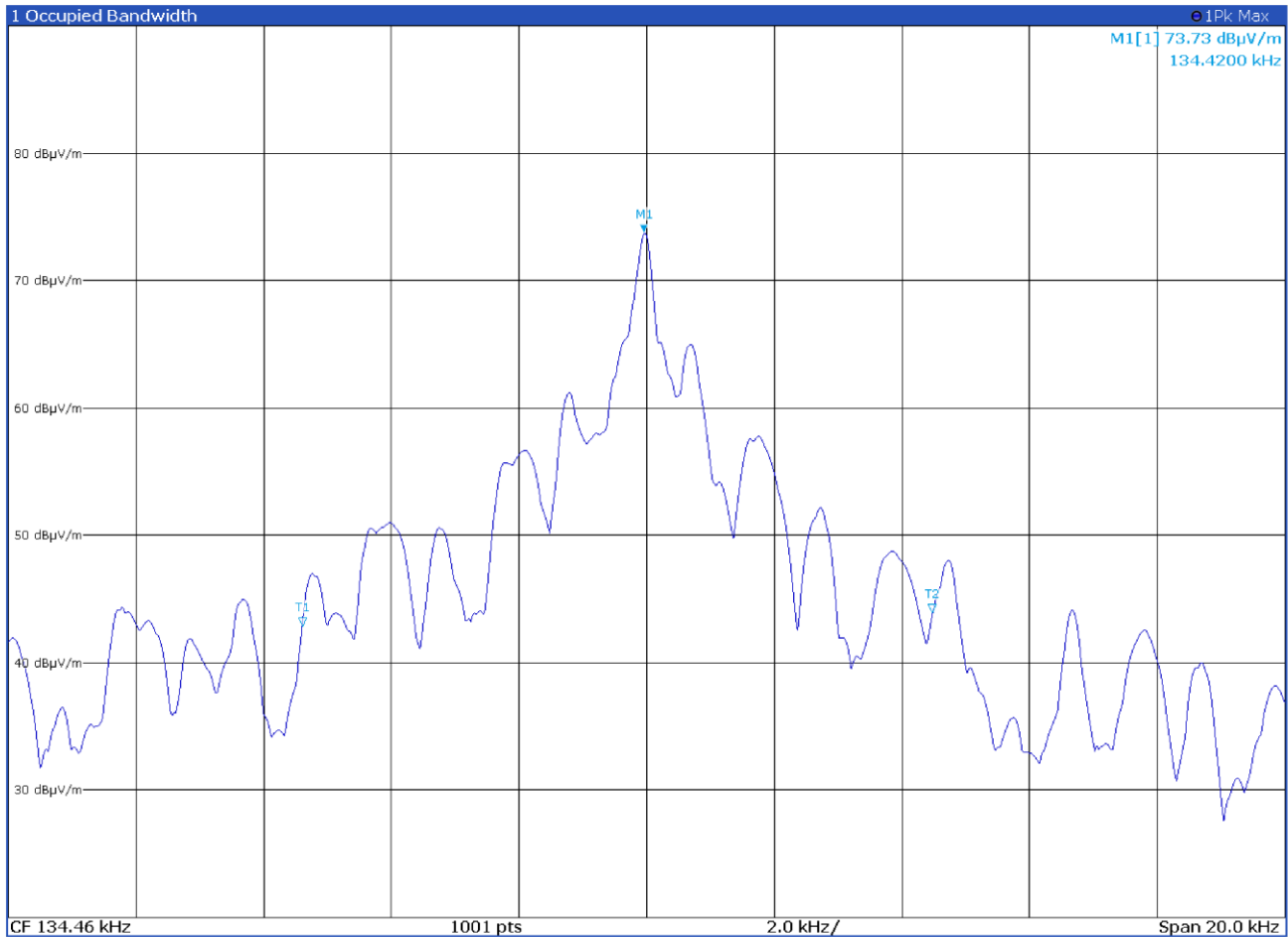

2 Marker Table							
Type	Ref	Trc	X-Value	Y-Value	Function	Function Result	
M1		1	134.42 kHz	73.73 dBµV/m	Occ Bw	9.852017332 kHz	
T1		1	129.0752 kHz	42.87 dBµV/m	Occ Bw Centroid	134.001226723 kHz	
T2		1	138.9272 kHz	43.91 dBµV/m	Occ Bw Freq Offset	-458.773277255 Hz	

Table 8.2-1: 99 % bandwidth results

Modulation	99 % bandwidth
FSK	9.85 kHz

8.3 FCC 15.209(a) and RSS-210, Radiated emissions limits

8.3.1 Definitions and limits

FCC:

- (a) Except as provided elsewhere in this subpart, the emissions from an intentional radiator shall not exceed the field strength levels specified in the Table 8.3-1 below.
- (c) The level of any unwanted emissions from an intentional radiator operating under these general provisions shall not exceed the level of the fundamental emission. For intentional radiators which operate under the provisions of other sections within this part and which are required to reduce their unwanted emissions to the limits specified in this table, the limits in this table are based on the frequency of the unwanted emission and not the fundamental frequency. However, the level of any unwanted emissions shall not exceed the level of the fundamental frequency.
- (d) The emission limits shown in the above table are based on measurements employing a CISPR quasi-peak detector except for the frequency bands 9–90 kHz, 110–490 kHz and above 1000 MHz. Radiated emission limits in these three bands are based on measurements employing an average detector.

IC:

Unless otherwise indicated, equipment for which emissions fall within the restricted frequency bands listed in RSS-Gen shall comply with the provisions set forth in RSS-Gen.

RSS-Gen includes the general field strength limits of unwanted emissions, where applicable, for transmitters and receivers operating in accordance with the provisions specified in this standard.

Unless otherwise indicated, unwanted emissions of transmitters and receivers are permitted to fall within the restricted frequency bands listed in RSS-Gen and the TV bands 54-72 MHz, 76-88 MHz, 174-216 MHz and 470-602 MHz; however, fundamental emissions are prohibited in these bands, except where equipment operation is permitted in the applicable RSS.

Transmitters whose wanted and unwanted emissions fall within the general field strength limits specified in RSS-Gen may operate licence-exempt in any of the frequency bands, other than the restricted frequency bands listed in RSS-Gen and the TV bands 54-72 MHz, 76-88 MHz, 174-216 MHz and 470-602 MHz, and shall be certified under RSS-210. Under no circumstances shall the level of any unwanted emissions exceed the level of the fundamental emissions

Devices operating below 490 kHz for which all emissions are at least 40 dB below the general field strength limit listed in RSS-Gen (for transmitters at frequencies below 30 MHz) are Category II devices and are subject to the requirements specified in RSS-310, Licence-Exempt Radio Apparatus: Category II Equipment.

Table 8.3-1: FCC §15.209 and RSS-Gen – Radiated emission limits

Frequency, MHz	Field strength of emissions		Measurement distance, m
	µV/m	dBµV/m	
0.009–0.490	2400/F	$67.6 - 20 \times \log_{10}(F)$	300
0.490–1.705	24000/F	$87.6 - 20 \times \log_{10}(F)$	30
1.705–30.0	30	29.5	30
30–88	100	40.0	3
88–216	150	43.5	3
216–960	200	46.0	3
above 960	500	54.0	3

Notes: In the emission table above, the tighter limit applies at the band edges.

For frequencies above 1 GHz the limit on peak RF emissions is 20 dB above the maximum permitted average emission limit applicable to the equipment under test.

Definitions and limits, continued

Table 8.3-2: IC restricted frequency bands

MHz	MHz	MHz	GHz
0.090–0.110	12.51975–12.52025	399.9–410	5.35–5.46
2.1735–2.1905	12.57675–12.57725	608–614	7.25–7.75
3.020–3.026	13.36–13.41	960–1427	8.025–8.5
4.125–4.128	16.42–16.423	1435–1626.5	9.0–9.2
4.17725–4.17775	16.69475–16.69525	1645.5–1646.5	9.3–9.5
4.20725–4.20775	16.80425–16.80475	1660–1710	10.6–12.7
5.677–5.683	25.5–25.67	1718.8–1722.2	13.25–13.4
6.215–6.218	37.5–38.25	2200–2300	14.47–14.5
6.26775–6.26825	73–74.6	2310–2390	15.35–16.2
6.31175–6.31225	74.8–75.2	2655–2900	17.7–21.4
8.291–8.294	108–138	3260–3267	22.01–23.12
8.362–8.366	156.52475–156.52525	3332–3339	23.6–24.0
8.37625–8.38675	156.7–156.9	3345.8–3358	31.2–31.8
8.41425–8.41475	240–285	3500–4400	36.43–36.5
12.29–12.293	322–335.4	4500–5150	Above 38.6

Note: Certain frequency bands listed in Table 8.3-2 and above 38.6 GHz are designated for low-power licence-exempt applications. These frequency bands and the requirements that apply to the devices are set out in this Standard

Table 8.3-3: FCC restricted frequency bands

MHz	MHz	MHz	GHz
0.090–0.110	16.42–16.423	399.9–410	4.5–5.15
0.495–0.505	16.69475–16.69525	608–614	5.35–5.46
2.1735–2.1905	16.80425–16.80475	960–1240	7.25–7.75
4.125–4.128	25.5–25.67	1300–1427	8.025–8.5
4.17725–4.17775	37.5–38.25	1435–1626.5	9.0–9.2
4.20725–4.20775	73–74.6	1645.5–1646.5	9.3–9.5
6.215–6.218	74.8–75.2	1660–1710	10.6–12.7
6.26775–6.26825	108–121.94	1718.8–1722.2	13.25–13.4
6.31175–6.31225	123–138	2200–2300	14.47–14.5
8.291–8.294	149.9–150.05	2310–2390	15.35–16.2
8.362–8.366	156.52475–156.52525	2483.5–2500	17.7–21.4
8.37625–8.38675	156.7–156.9	2690–2900	22.01–23.12
8.41425–8.41475	162.0125–167.17	3260–3267	23.6–24.0
12.29–12.293	167.72–173.2	3332–3339	31.2–31.8
12.51975–12.52025	240–285	3345.8–3358	36.43–36.5
12.57675–12.57725	322–335.4	3600–4400	Above 38.6
13.36–13.41			

8.3.2 Test summary

Verdict	Pass		
Tested by	Oscar Frau	Test date	September 15, 2023

8.3.3 Observations, settings and special notes

The spectrum was searched from 30 MHz to the 10th harmonic.
 Radiated measurements were performed at a distance of 3 m

Receiving settings for radiated measurements below 150 kHz:

Resolution bandwidth:	200 Hz
Detector mode:	Peak
Trace mode:	Max Hold

Receiving settings for radiated measurements below 30 MHz:

Resolution bandwidth:	9 kHz
Detector mode:	Peak
Trace mode:	Max Hold

Receiving settings for radiated measurements below 1 GHz:

Resolution bandwidth:	120 kHz
Detector mode:	Peak
Trace mode:	Max Hold

8.3.4 Test equipment used

Equipment	Manufacturer	Model no.	Asset no.
EMI Receiver	Rohde & Schwarz	ESW44	101620
Antenna Loop Attiva+Power Inserter	Teseq	HLA6121+PI6121	45749
Antenna Trilog 25MHz - 8GHz	Schwarzbeck Mess-Elektronik	VULB9162	9162-025
Antenna 1 - 18 GHz	Schwarzbeck Mess-Elektronik	STLP9148	STLP 9148-152
Broadband Amplifier	Schwarzbeck Mess-Elektronik	BBV9718	BBV9718-137
Controller	Maturo	FCU3.0	10041
Tilt antenna mast	Maturo	TAM4.0-E	10042
Turntable	Maturo	TT4.0-5T	2.527
Semi-anechoic chamber	Nemko S.p.a.	10m semi-anechoic chamber	530

8.3.5 Test data

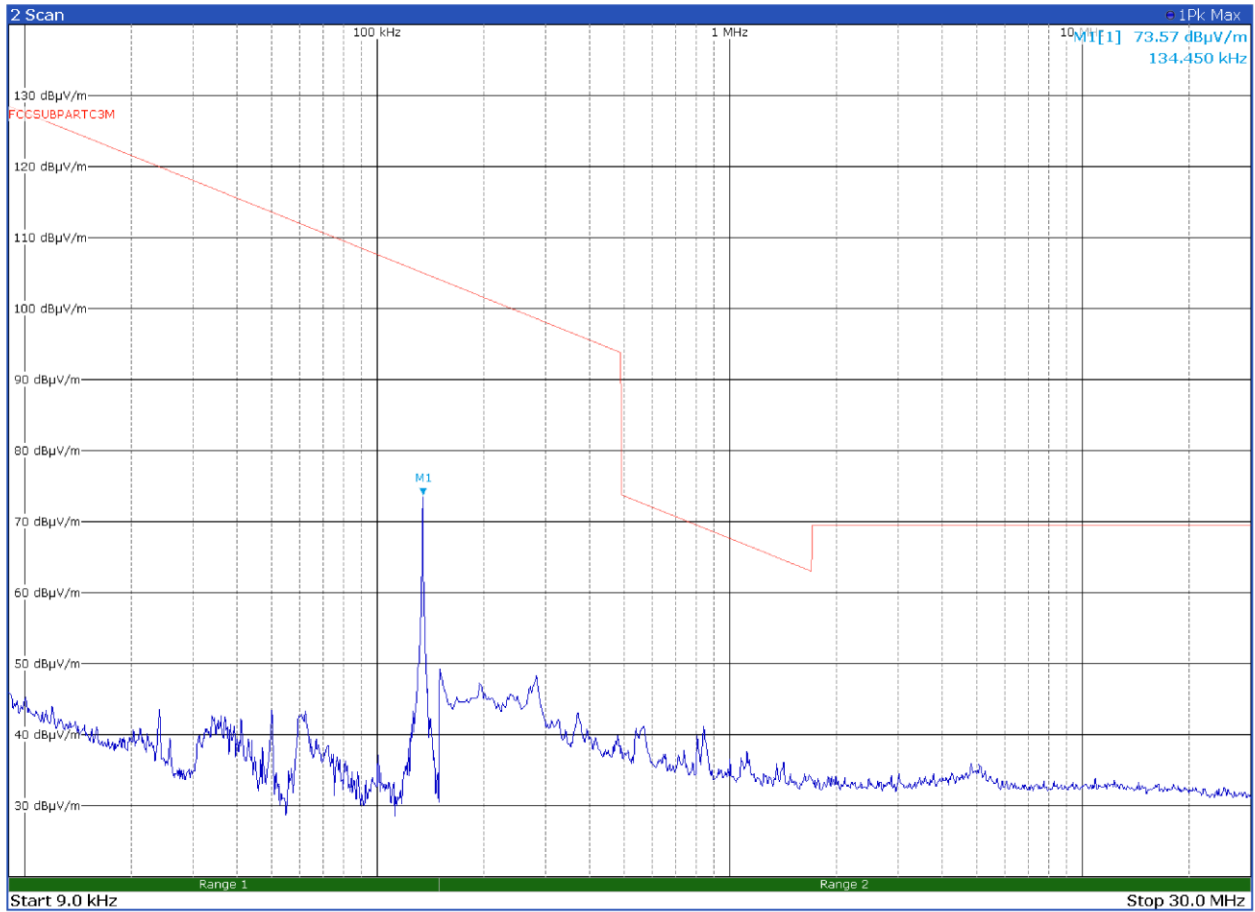

Figure 8.3-1: Radiated emissions with antenna loop (9 kHz – 30 MHz)

Test data, continued

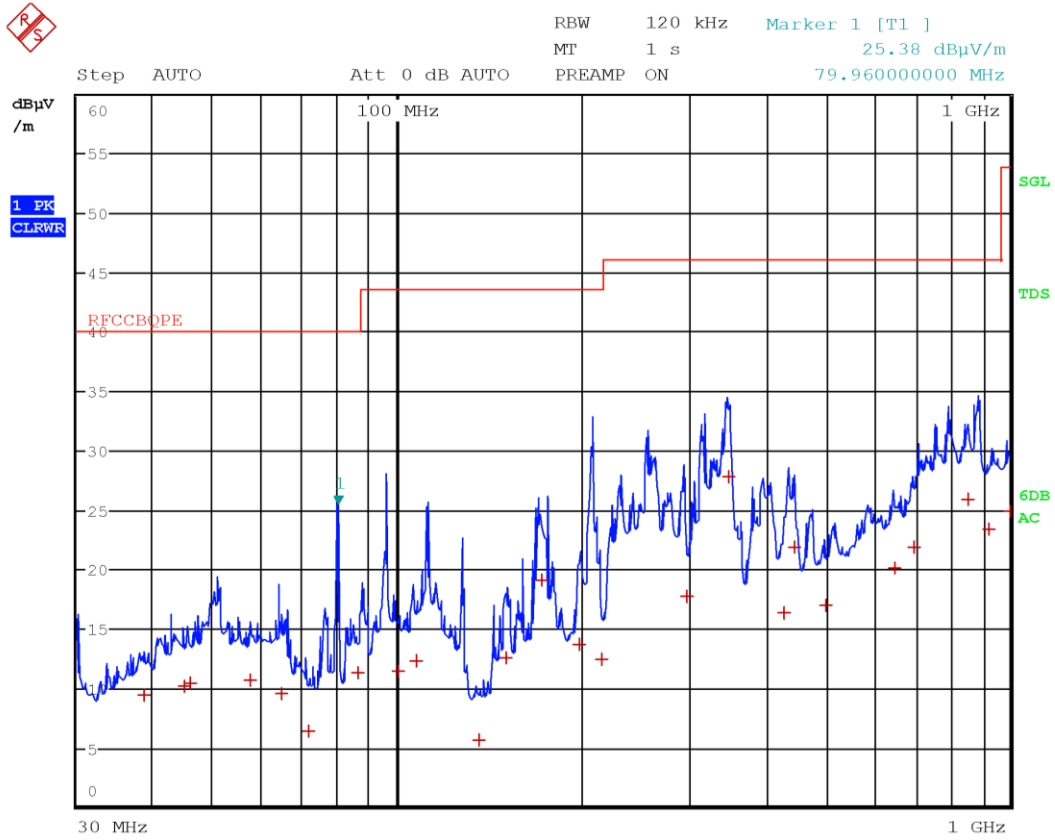

Figure 8.3-2: Radiated emissions with antenna in horizontal polarization (30 - 1000 MHz)

Test data, continued

Frequency (MHz)	Level (dB μ V/m)	Limit (dB μ V/m)	Margin (dB)	Detector
38.6800	9.4	40.0	-30.6	QP
45.0000	10.2	40.0	-29.8	QP
46.0400	10.4	40.0	-29.6	QP
57.4400	10.7	40.0	-29.3	QP
64.6000	9.5	40.0	-30.5	QP
71.7600	6.4	40.0	-33.6	QP
86.0800	11.3	40.0	-28.7	QP
100.4000	11.4	43.5	-32.1	QP
107.6400	12.3	43.5	-31.2	QP
136.2000	5.6	43.5	-37.9	QP
150.6000	12.5	43.5	-31.0	QP
172.2000	19.2	43.5	-24.3	QP
198.0000	13.7	43.5	-29.8	QP
215.2000	12.4	43.5	-31.1	QP
297.0000	17.7	46.0	-28.2	QP
346.4800	27.8	46.0	-18.2	QP
427.8800	16.4	46.0	-29.6	QP
445.4800	21.8	46.0	-24.2	QP
499.9600	16.9	46.0	-29.1	QP
648.0000	20.1	46.0	-25.9	QP
696.0000	21.9	46.0	-24.1	QP
856.0000	25.9	46.0	-20.1	QP
926.0400	23.4	46.0	-22.6	QP
1000.0000	24.8	53.9	-29.2	QP

Test data, continued

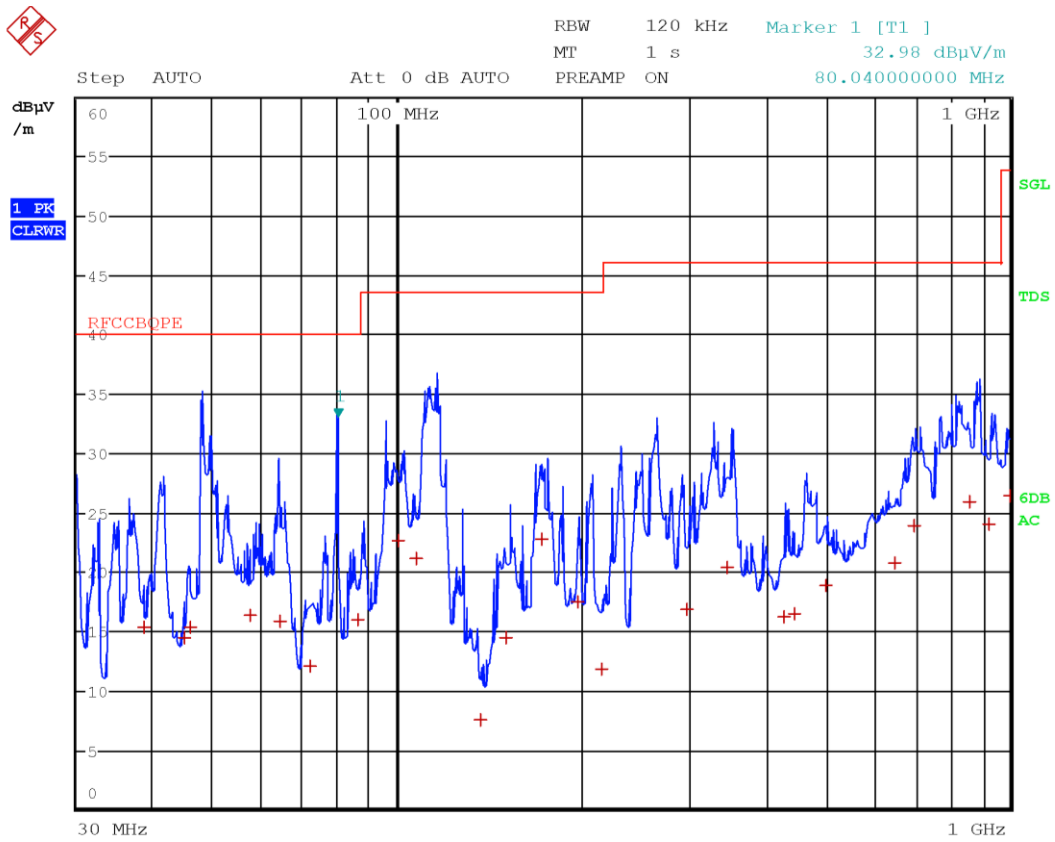

Figure 8.3-3: Radiated emissions with antenna in vertical polarization (30 - 1000 MHz)

Test data, continued

Frequency (MHz)	Level (dB μ V/m)	Limit (dB μ V/m)	Margin (dB)	Detector
38.6800	15.4	40.0	-24.6	QP
45.0000	14.5	40.0	-25.5	QP
46.0400	15.3	40.0	-24.7	QP
57.4400	16.3	40.0	-33.7	QP
64.6000	15.9	40.0	-24.1	QP
71.7600	12.0	40.0	-28.0	QP
86.0800	15.9	40.0	-24.1	QP
100.4000	22.7	43.5	-20.8	QP
107.6400	21.2	43.5	-22.3	QP
136.2000	7.5	43.5	-36.0	QP
150.6000	14.4	43.5	-29.1	QP
172.2000	22.7	43.5	-20.8	QP
198.0000	17.4	43.5	-26.1	QP
215.2000	11.8	43.5	-31.7	QP
297.0000	16.8	46.0	-29.2	QP
346.4800	20.4	46.0	-25.6	QP
427.8800	16.2	46.0	-29.8	QP
445.4800	16.5	46.0	-29.5	QP
499.9600	18.8	46.0	-27.2	QP
648.0000	20.7	46.0	-25.3	QP
696.0000	23.9	46.0	-22.1	QP
856.0000	25.9	46.0	-20.1	QP
926.0400	24.1	46.0	-21.9	QP
1000.0000	26.4	53.9	-27.6	QP

Section 9. Block diagrams of test set-ups and EUT photos

9.1 Radiated emissions set-up below 30 MHz

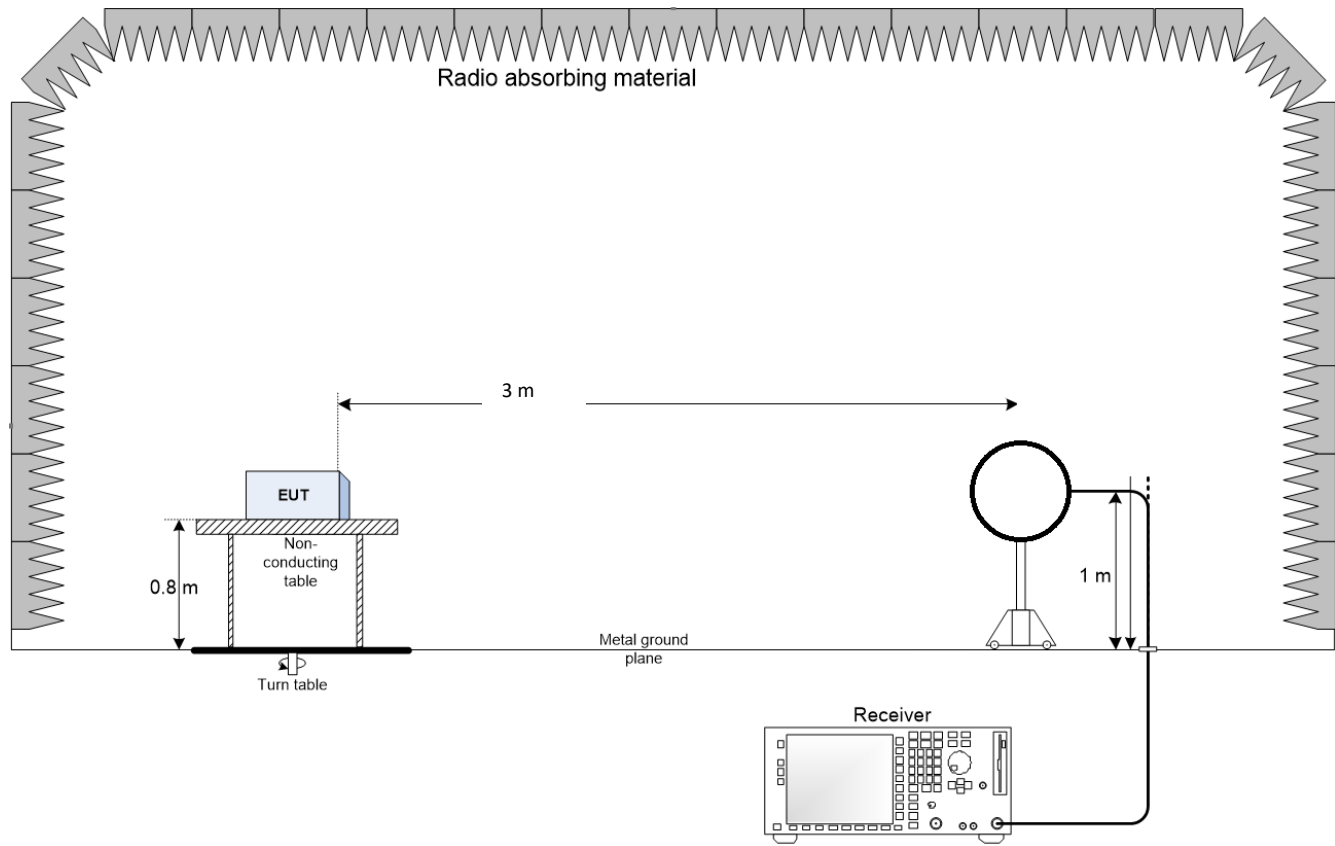

9.2 Radiated emissions set-up below 1 GHz

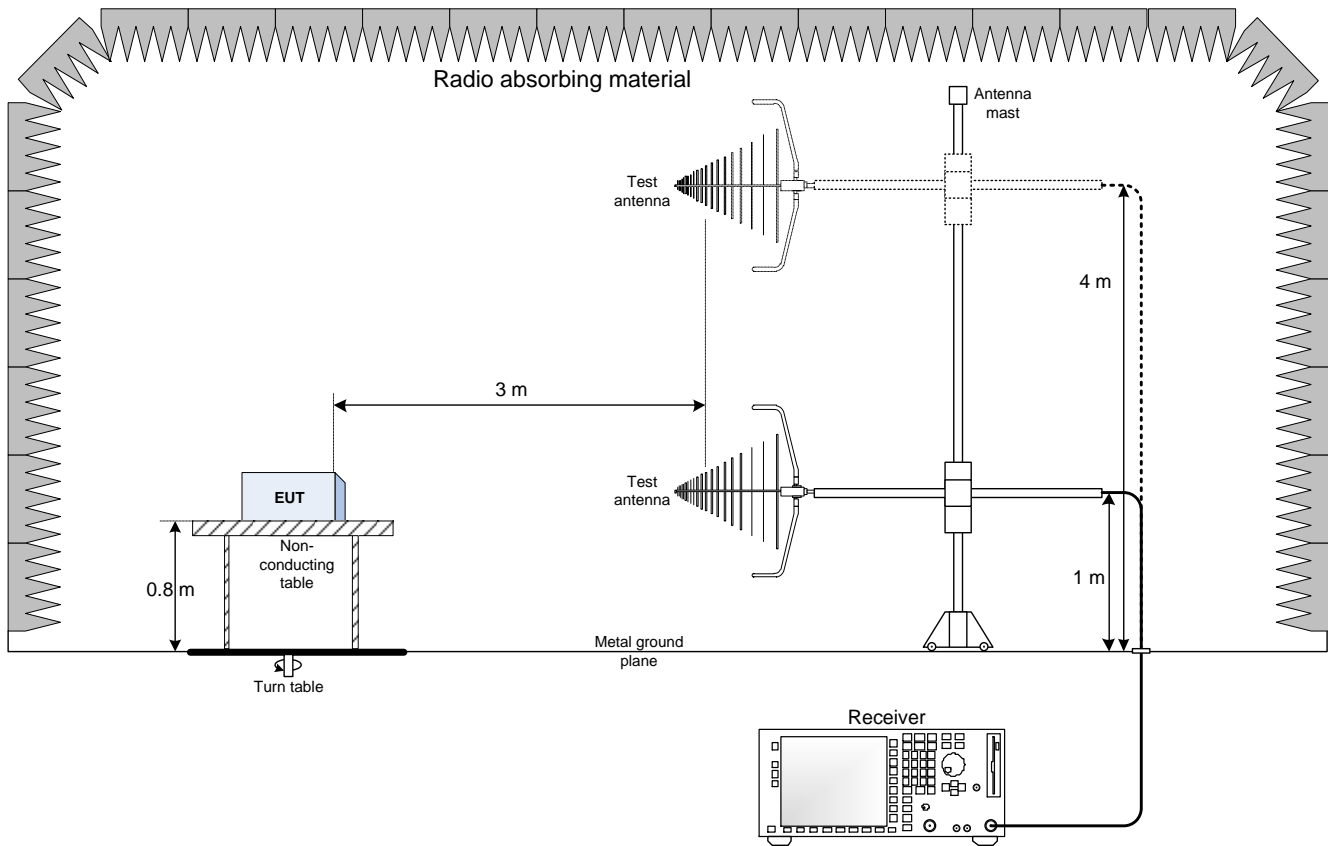

9.3 Set-up photos



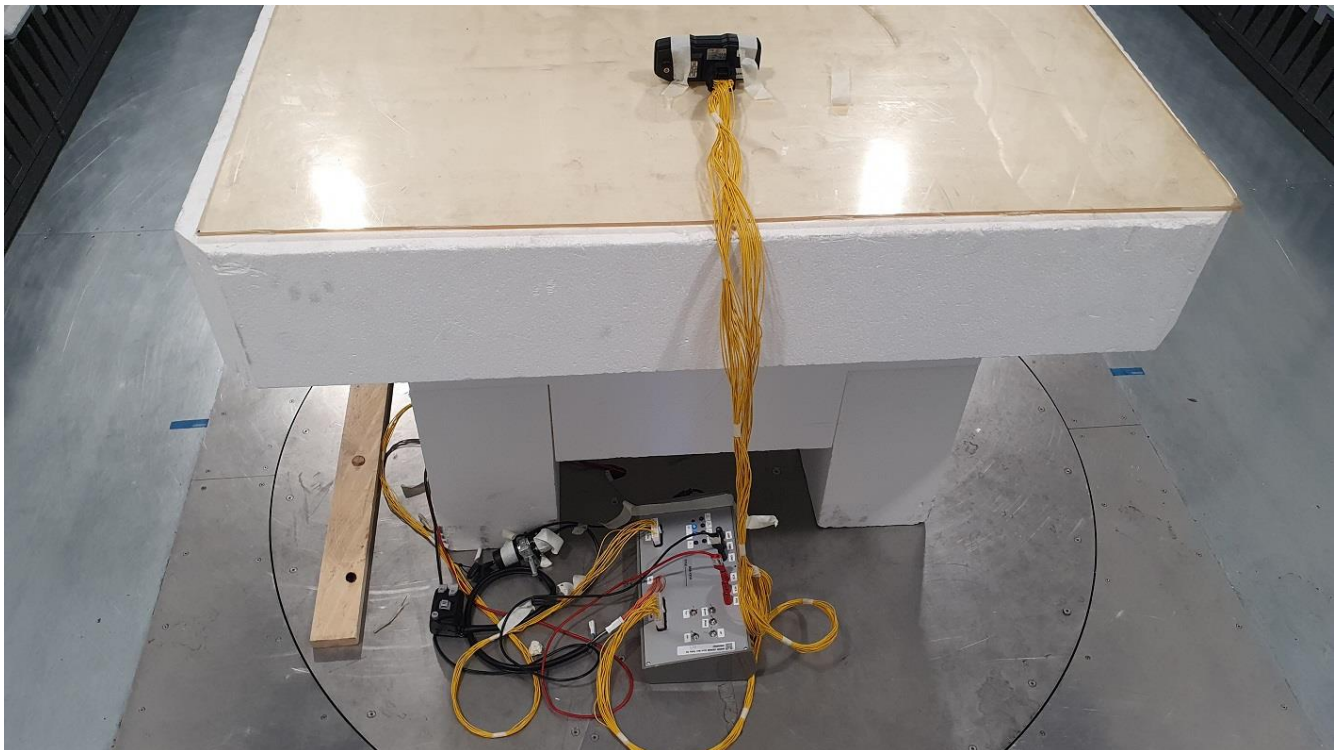
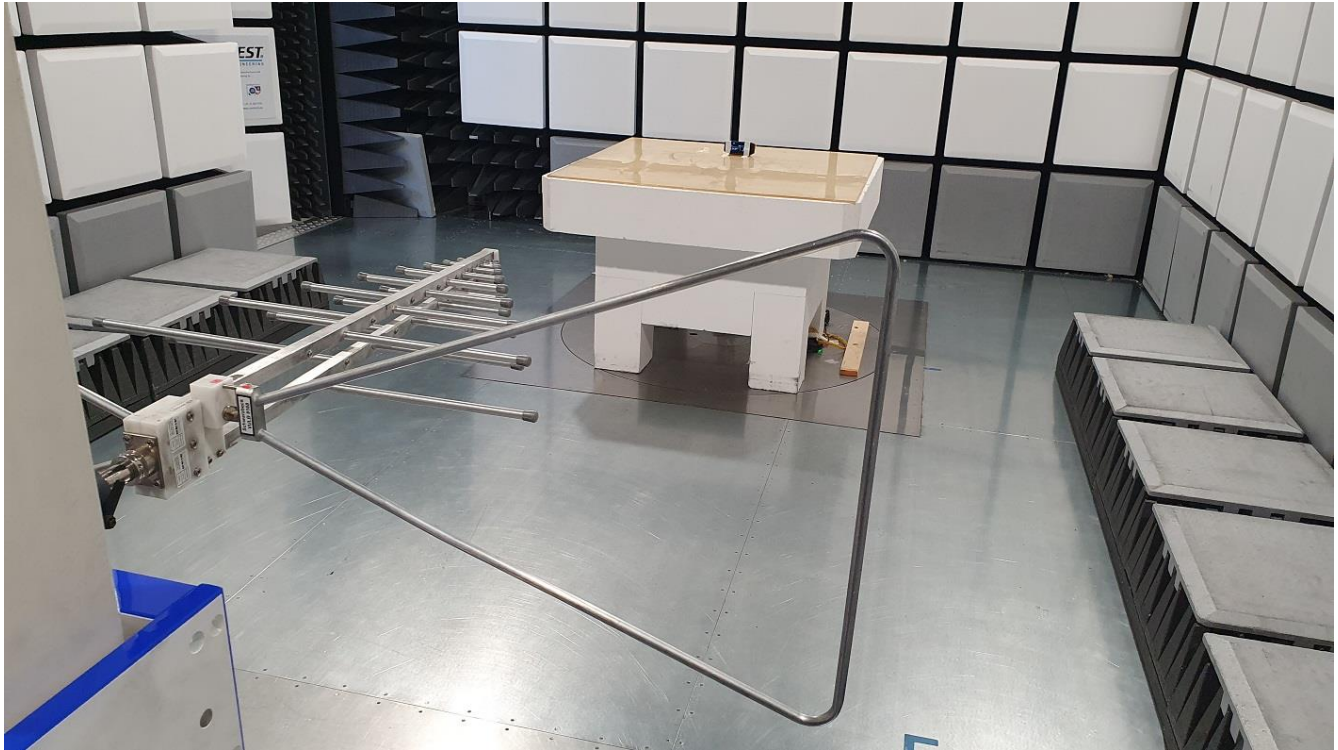

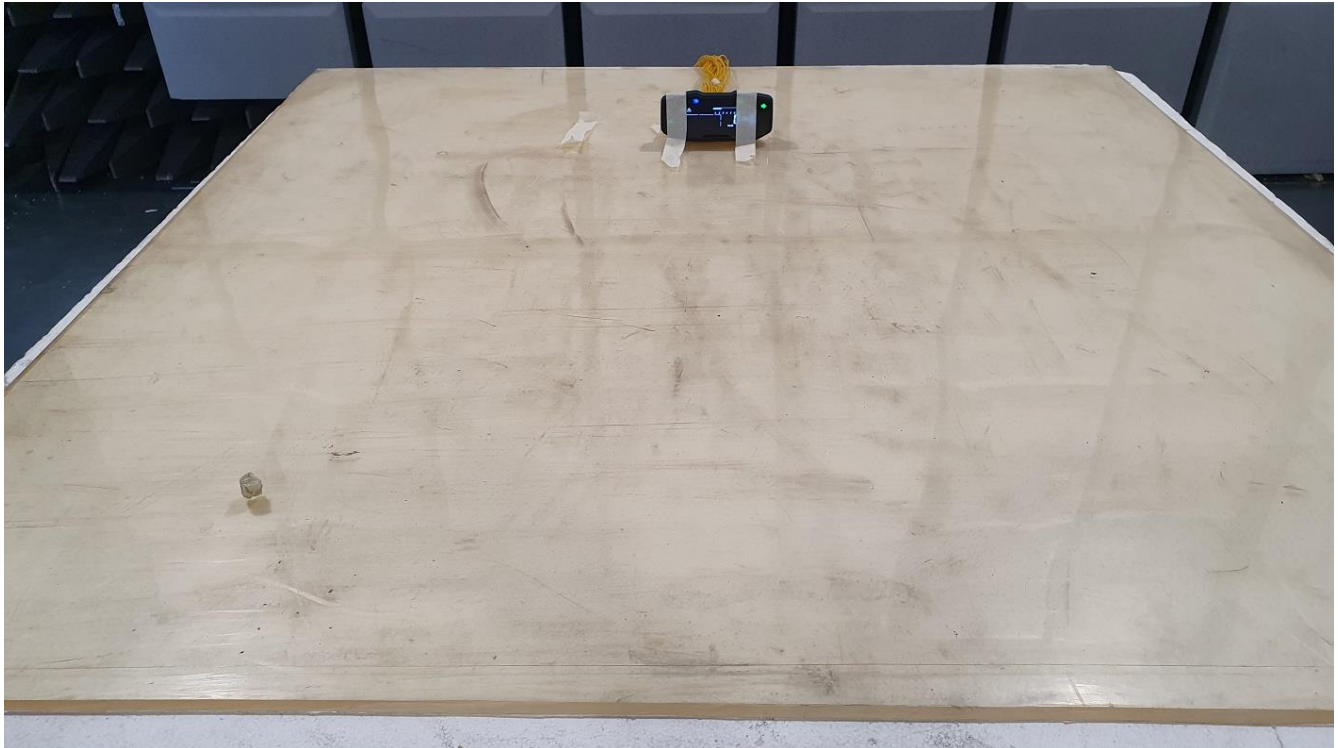

9.4 EUT photos



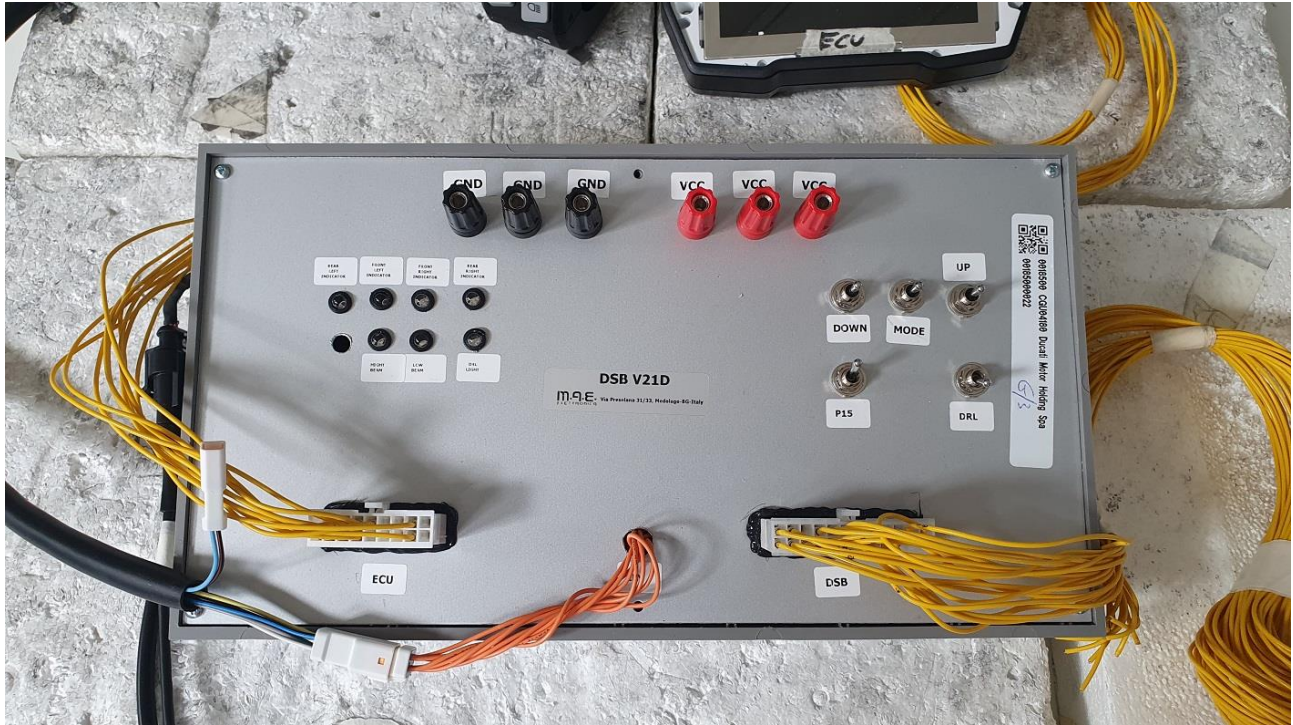

(not under test)



(not under test)

End of report