

MAE-DEX-PANV4-User Manual-01-200115

**DASHBOARD for PANV4 MODEL**  
**User Manual**

|             |                   |             |
|-------------|-------------------|-------------|
| Filled In:  | Checked:          | Approved:   |
| I.Locatelli | Claudia Gravalini | F.Gravalini |

MAE-DEX-PANV4-User Manual-01-200115

1. COMPONENT LAYOUT – COMPLETE VIEW:

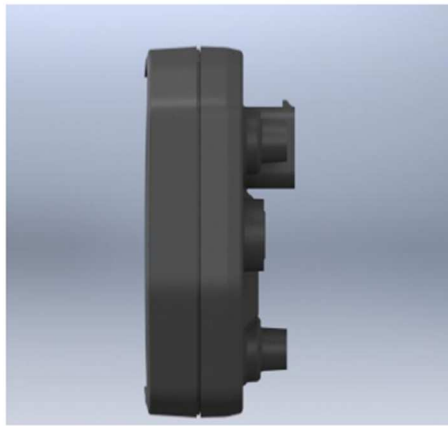
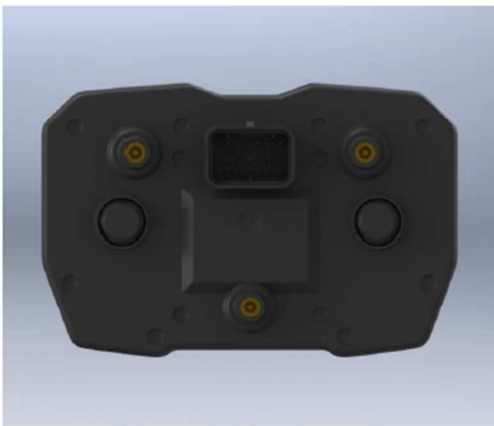

## 2. IMMOBILIZER SYSTEM:

Key electronic codes are stored inside instrument panel control unit, which serves as Immobilizer. The transponder contained inside each key is powered by the antenna inside the key switch. Instrument panel control unit reads the electronic code stored inside the key and compares it to the codes enabled for engine start, then it communicates to engine control unit - through the CAN line - whether engine starting can be enabled.

Key electronic codes are stored inside instrument panel control unit, which serves as Immobilizer. The transponder contained inside each key (A) is powered by the antenna inside the key switch (B). Instrument panel control unit (C) reads the electronic code stored inside the key and compares it to the codes enabled for engine start, then it communicates to engine control unit - through the CAN line - whether engine starting can be enabled.

The activations must be performed only with key turned to ON, engine off and battery voltage  $\geq 11.0V$ .



### 3. NOTES

Changes or modifications not expressly approved by the party responsible for compliance could void the user's authority to operate the equipment

This device model PANV4 is listed under FCC ID: 2AVGH-PANV4; IC: 25794-PANV4

This device complies with FCC and ISED radiation exposure limits for uncontrolled environment. The antenna should be installed and operated with minimum distance of 20 cm between the radiator and your body.

#### **Canada:**

This device contains license-exempt transmitter(s)/receiver(s) that comply with Innovation, Science and Economic Development Canada's license exempt RSS(s). Operation is subject to the following two conditions: (1) This device may not cause interference. (2) This device must accept any interference, including interference that may cause undesired operation of the device.

*L'émetteur/recepteur exempt de licence contenu dans le present appareil est conforme aux CNR d'Innovation, Sciences et Developpement economique Canada applicables aux appareils radio exempts de licence. L'exploitation est autorisee aux deux conditions suivantes : (1) L'appareil ne doit pas produire de brouillage; (2) L'appareil doit accepter tout brouillage radioelectrique subi, meme si le brouillage est susceptible d'en compromettre le fonctionnement. 8*

ICES-003 Class B Notice -Avis NMB-003 Classe B:

This Class B digital device complies with Canadian ICES-003

*Cet appareil numerique classe B est conforme à la norme Canadien NMB-003.*

CAN ICES-3(B) /NMB-3(B)

#### **FCC USA:**

This device complies with Part 15 of the FCC rules subject to the following two conditions:

This device may not cause harmful interference.

This device must accept all interference received, including interference that may cause undesired operation.

This equipment has been tested and found to comply with the limits for a Class B digital device, pursuant to part 15 of the FCC Rules. These limits are designed to provide reasonable protection against harmful interference in a residential installation. This equipment generates, uses and can radiate radio frequency energy and, if not installed and used in accordance with the instructions, may cause harmful interference to radio communications. However, there is no guarantee that interference will not occur in a particular installation. If this equipment does cause harmful interference to radio or television reception, which can be determined by turning the equipment off and on, the user is encouraged to try to correct the interference by one or more of the following measures:

- Reorient or relocate the receiving antenna.
- Increase the separation between the equipment and receiver.
- Connect the equipment into an outlet on a circuit different from that to which the receiver is connected.
- Consult the dealer or an experienced radio/TV technician for help

MAE-DEX-PANV4-User Manual-01-200115

**CANADIAN REPRESENTATIVE INFORMATION**

|                               |                        |
|-------------------------------|------------------------|
| Company Name:                 | Ducati Canada          |
| Company Number <sup>1</sup> : | 23452                  |
| Company Address:              | 777 Bayly Ave.         |
| City:                         | Ajax                   |
| Province/State:               | ON                     |
| Postal Code:                  | L1S7G7                 |
| Country:                      | Canada                 |
| Contact Name:                 | Steve Hicks            |
| Phone Number:                 | +17058782231           |
| Email:                        | steve.hicks@ducati.com |