



# MEASUREMENT REPORT

## FCC PART 27

---

**FCC ID:** ZMOFM101NA  
**Applicant:** Fibocom Wireless Inc.

**Application Type:** Certification  
**Product:** LTE Module  
**Model No.:** FM101-NA  
**Brand Name:** Fibocom  
**FCC Rule Part(s):** Part 27 Subpart D  
**Test Procedure(s):** ANSI C63.26: 2015  
**Test Date:** November 05 ~ 26, 2021

**Reviewed By:** 

**Approved By:** 



The test results relate only to the samples tested.  
This equipment has been shown to be capable of compliance with the applicable technical standards as indicated in the measurement report and was tested in accordance with the measurement procedures specified in ANSI C63.26-2015. Test results reported herein relate only to the item(s) tested.  
The test report shall not be reproduced except in full without the written approval of MRT Technology (Suzhou) Co., Ltd.

## Revision History

Report No.	Version	Description	Issue Date	Note
2110RSU053-U5	Rev. 01	Initial Report	12-17-2021	Invalid
2110RSU053-U5	Rev. 02	Corrected the calibration date of equipment	12-23-2021	Valid

---

## CONTENTS

Description	Page
<b>1. GENERAL INFORMATION.....</b>	<b>5</b>
1.1. Applicant.....	5
1.2. Manufacturer.....	5
1.3. Testing Facility.....	5
<b>2. PRODUCT INFORMATION .....</b>	<b>6</b>
2.1. Product Information .....	6
2.2. Radio Specification under Test .....	6
2.3. Description of Available Antennas.....	7
2.4. Test Methodology.....	7
2.5. EMI Suppression Device(s)/Modifications .....	7
2.6. Configuration of Tested System .....	8
2.7. Test Environment Condition.....	8
<b>3. TEST EQUIPMENT CALIBRATION DATE.....</b>	<b>9</b>
<b>4. MEASUREMENT UNCERTAINTY.....</b>	<b>10</b>
<b>5. TEST RESULT .....</b>	<b>11</b>
5.1. Summary .....	11
5.2. Occupied Bandwidth Measurement.....	12
5.2.1. Test Limit.....	12
5.2.2. Test Procedure.....	12
5.2.3. Test Setting .....	12
5.2.4. Test Setup .....	12
5.2.5. Test Result .....	13
5.3. Frequency Stability Measurement .....	14
5.3.1. Test Limit.....	14
5.3.2. Test Procedure.....	14
5.3.3. Test Setting .....	14
5.3.4. Test Setup .....	15
5.3.5. Test Result .....	16
5.4. Equivalent Isotropically Radiated Power Measurement .....	17
5.4.1. Test Limit.....	17
5.4.2. Test Procedure.....	17
5.4.3. Test Setting .....	17
5.4.4. Test Setup .....	18
5.4.5. Test Result .....	19

---

5.5.	Band Edge Measurement .....	20
5.5.1.	Test Limit.....	20
5.5.2.	Test Procedure .....	20
5.5.3.	Test Setting .....	20
5.5.4.	Test Setup .....	21
5.5.5.	Test Result .....	22
5.6.	Conducted Spurious Emission Measurement.....	25
5.6.1.	Test Limit.....	25
5.6.2.	Test Procedure .....	25
5.6.3.	Test Setting .....	25
5.6.4.	Test Setup .....	26
5.6.5.	Test Result .....	27
5.7.	Radiated Spurious Emission Measurement.....	29
5.7.1.	Test Limit.....	29
5.7.2.	Test Procedure.....	29
5.7.3.	Test Setting .....	29
5.7.4.	Test Setup .....	29
5.7.5.	Test Result .....	31
<b>6.</b>	<b>CONCLUSION .....</b>	<b>32</b>
	<b>Appendix A - Test Setup Photograph .....</b>	<b>33</b>
	<b>Appendix B - EUT Photograph .....</b>	<b>34</b>

## 1. GENERAL INFORMATION

### 1.1. Applicant

Fibocom Wireless Inc.

1101, Tower A, Building 6, Shenzhen International Innovation Valley, Dashi 1<sup>st</sup> Rd, Nanshan, Shenzhen, China

### 1.2. Manufacturer

Fibocom Wireless Inc.

1101, Tower A, Building 6, Shenzhen International Innovation Valley, Dashi 1<sup>st</sup> Rd, Nanshan, Shenzhen, China

### 1.3. Testing Facility

<input checked="" type="checkbox"/>	<p><b>Test Site – MRT Suzhou Laboratory</b></p> <p><b>Laboratory Location (Suzhou - Wuzhong)</b> D8 Building, No.2 Tian’edang Rd., Wuzhong Economic Development Zone, Suzhou, China</p> <p><b>Laboratory Location (Suzhou - SIP)</b> 4b Building, Liando U Valley, No.200 Xingpu Rd., Shengpu Town, Suzhou Industrial Park, China</p> <p><b>Laboratory Accreditations</b></p> <table style="width: 100%; border: none;"> <tr> <td style="width: 50%;">A2LA: 3628.01</td> <td style="width: 50%;">CNAS: L10551</td> </tr> <tr> <td>FCC: CN1166</td> <td>ISED: CN0001</td> </tr> <tr> <td>VCCI: <input type="checkbox"/>R-20025</td> <td><input type="checkbox"/>G-20034 <input type="checkbox"/>C-20020 <input type="checkbox"/>T-20020</td> </tr> <tr> <td><input type="checkbox"/>R-20141</td> <td><input type="checkbox"/>G-20134 <input type="checkbox"/>C-20103 <input type="checkbox"/>T-20104</td> </tr> </table>	A2LA: 3628.01	CNAS: L10551	FCC: CN1166	ISED: CN0001	VCCI: <input type="checkbox"/> R-20025	<input type="checkbox"/> G-20034 <input type="checkbox"/> C-20020 <input type="checkbox"/> T-20020	<input type="checkbox"/> R-20141	<input type="checkbox"/> G-20134 <input type="checkbox"/> C-20103 <input type="checkbox"/> T-20104
A2LA: 3628.01	CNAS: L10551								
FCC: CN1166	ISED: CN0001								
VCCI: <input type="checkbox"/> R-20025	<input type="checkbox"/> G-20034 <input type="checkbox"/> C-20020 <input type="checkbox"/> T-20020								
<input type="checkbox"/> R-20141	<input type="checkbox"/> G-20134 <input type="checkbox"/> C-20103 <input type="checkbox"/> T-20104								
<input type="checkbox"/>	<p><b>Test Site – MRT Shenzhen Laboratory</b></p> <p><b>Laboratory Location (Shenzhen)</b> 1G, Building A, Junxiangda Building, Zhongshanyuan Road West, Nanshan District, Shenzhen, China</p> <p><b>Laboratory Accreditations</b></p> <table style="width: 100%; border: none;"> <tr> <td style="width: 50%;">A2LA: 3628.02</td> <td style="width: 50%;">CNAS: L10551</td> </tr> <tr> <td>FCC: CN1284</td> <td>ISED: CN0105</td> </tr> </table>	A2LA: 3628.02	CNAS: L10551	FCC: CN1284	ISED: CN0105				
A2LA: 3628.02	CNAS: L10551								
FCC: CN1284	ISED: CN0105								
<input type="checkbox"/>	<p><b>Test Site – MRT Taiwan Laboratory</b></p> <p><b>Laboratory Location (Taiwan)</b> No. 38, Fuxing 2nd Rd., Guishan Dist., Taoyuan City 333, Taiwan (R.O.C.)</p> <p><b>Laboratory Accreditations</b></p> <table style="width: 100%; border: none;"> <tr> <td style="width: 50%;">TAF: L3261-190725</td> <td style="width: 50%;"></td> </tr> <tr> <td>FCC: 291082, TW3261</td> <td>ISED: TW3261</td> </tr> </table>	TAF: L3261-190725		FCC: 291082, TW3261	ISED: TW3261				
TAF: L3261-190725									
FCC: 291082, TW3261	ISED: TW3261								

## 2. PRODUCT INFORMATION

### 2.1. Product Information

Product Name	LTE Module
Model No.	FM101-NA
Brand Name	Fibocom
IMEI	Conducted Measurement: 867141050004112 Radiated Measurement: 867141050004062
Operating Temperature	-30 ~ 75 °C
Power Type	3.135 ~ 4.4Vdc, typical 3.8Vdc
Antenna Information	Refer to Section 2.3
UMTS Specification	
Single Band	Band 2, 4, 5
Modulation	Uplink up to 16QAM, Downlink up to 64QAM
E-UTRA Specification	
Single Band	Band 2, 4, 5, 7, 12, 13, 14, 17, 25, 26, 30, 41, 42, 43, 48, 66, 71
HPUE Band	Band 41
Modulation	Uplink up to 16QAM, Downlink up to 64QAM

Note: The information of EUT was provided by the manufacturer, and the accuracy of the information shall be the responsibility of the manufacturer.

### 2.2. Radio Specification under Test

FDD T <sub>x</sub> Frequency Range	Band 30: 2305 ~ 2315 MHz
FDD R <sub>x</sub> Frequency Range	Band 30: 2350 ~ 2360 MHz

Note: For other features of this EUT, test reports will be issued separately.

### 2.3. Description of Available Antennas

Technology	Frequency Range (MHz)	Antenna Type	Max Peak Gain (dBi)
LTE Band 2	1850 ~ 1910	PIFA	2.63
LTE Band 4	1710 ~ 1755		2.86
LTE Band 5	824 ~ 849		1.61
LTE Band 7	2500 ~ 2570		1.07
LTE Band 12	699 ~ 716		1.61
LTE Band 13	777 ~ 787		2.19
LTE Band 14	788 ~ 798		2.22
LTE Band 17	704 ~ 716		1.61
LTE Band 25	1850 ~ 1915		2.63
LTE Band 26	814 ~ 849		1.93
LTE Band 30	2305 ~ 2315		0.67
LTE Band 41	2496 ~ 2690		2.49
LTE Band 42	3450 ~ 3550		-1.18
LTE Band 42	3550 ~ 3600		-1.18
LTE Band 43	3600 ~ 3700		-0.13
LTE Band 43	3700 ~ 3800		-0.71
LTE Band 48	3550 ~ 3700		-0.13
LTE Band 66	1710 ~ 1780		3.76
LTE Band 71	663 ~ 698		1.39

### 2.4. Test Methodology

According to the specifications of the manufacturer, the EUT must comply with the requirements of the following standards:

- ANSI C63.26:2015
- FCC CFR 47 Part 27
- FCC KDB 971168 D01 v03r01: Power Meas License Digital Systems
- FCC KDB 971168 D02 v02r01: Misc Rev Approv License Devices
- FCC KDB 412172 D01 v01r01: Determining ERP and EIRP

### 2.5. EMI Suppression Device(s)/Modifications

No EMI suppression device(s) were added and/or no modifications were made during testing.

## 2.6. Configuration of Tested System

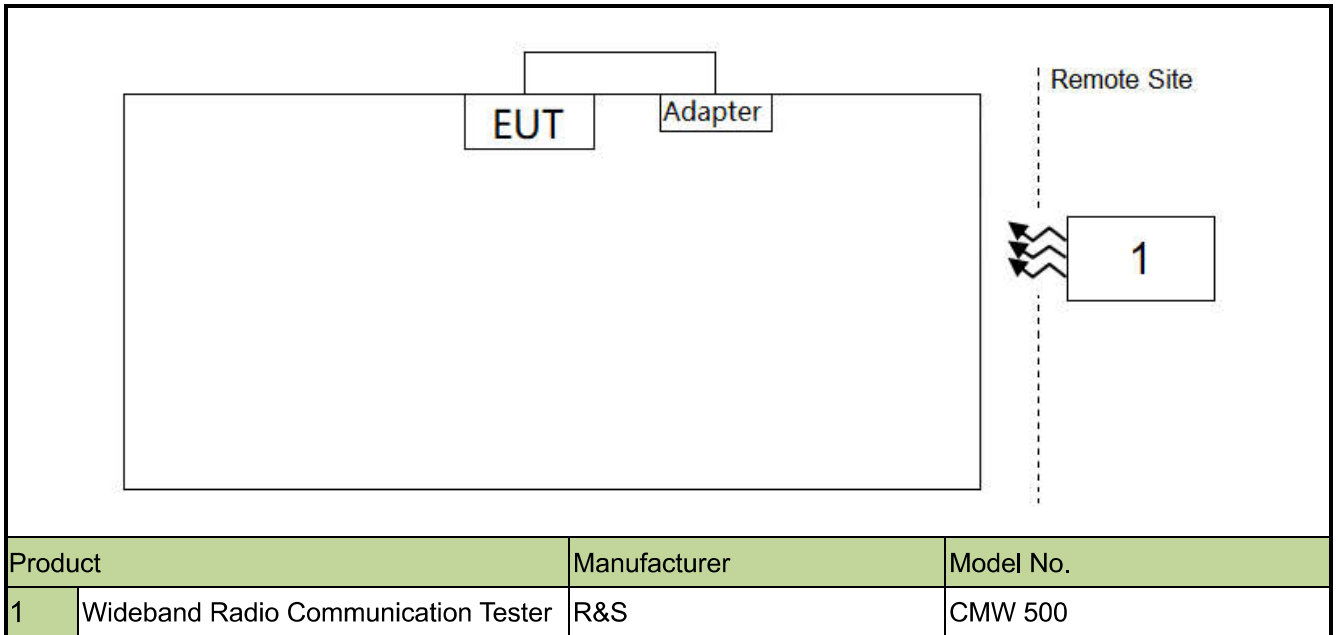

## 2.7. Test Environment Condition

Ambient Temperature	15 ~ 35°C
Relative Humidity	20% ~ 75%RH



### 3. TEST EQUIPMENT CALIBRATION DATE

Instrument Name	Manufacturer	Model No.	Asset No.	Cali. Interval	Cal. Due Date	Test Site
Communication Tester	R&S	CMU 200	MRTSUE06009	1 year	2022/9/7	SIP-SR1
Communication Tester	R&S	CMW500	MRTSUE06243	1 year	2022/10/10	SIP-SR1
Signal Generator	Keysight	E8257D	MRTSUE06453	1 year	2022/6/24	SIP-SR1
Thermohygrometer	testo	622	MRTSUE06629	1 year	2022/11/2	SIP-SR1
Signal Generator	Keysight	E8257D	MRTSUE06904	1 year	2021/12/8	SIP-SR1
Signal Generator	Keysight	E8257D	MRTSUE06904	1 year	2022/11/23	SIP-SR1
DC POWER MODULE	Keysight	N6743B	MRTSUE06905	/	/	SIP-SR1
DC POWER MODULE	Keysight	N6743B	MRTSUE06906	/	/	SIP-SR1
Low-Profile Modular Power System Mainframe	Keysight	N6700C	MRTSUE06907	/	/	SIP-SR1
Signal Analyzer	Keysight	N9021B	MRTSUE06915	1 year	2022/1/18	SIP-SR1
Temperature Chamber	BAOYT	BYG-80CL	MRTSUE06932	1 year	2022/3/16	SIP-SR1
Shielding Room	MIX-BEP	SIP-SR1	MRTSUE06948	/	/	SIP-SR1
EMI Test Receiver	R&S	ESR3	MRTSUE06185	1 year	2022/1/12	SIP-AC2
Signal Analyzer	Keysight	N9010B	MRTSUE06559	1 year	2022/6/24	SIP-AC2
Horn Antenna	Schwarzbeck	BBHA 9170	MRTSUE06599	1 year	2022/10/20	SIP-AC2
Preamplifier	EMCI	EMC184045SE	MRTSUE06602	1 year	2022/10/11	SIP-AC2
Thermohygrometer	testo	608-H1	MRTSUE06623	1 year	2021/12/3	SIP-AC2
Thermohygrometer	testo	608-H1	MRTSUE06624	1 year	2021/12/3	SIP-AC2
Preamplifier	EMCI	EMC051845SE	MRTSUE06644	1 year	2021/11/26	SIP-AC2
Preamplifier	EMCI	EMC051845SE	MRTSUE06644	1 year	2022/11/8	SIP-AC2
TRILOG Antenna	Schwarzbeck	VULB 9168	MRTSUE06647	1 year	2022/8/5	SIP-AC2
Horn Antenna	Schwarzbeck	BBHA 9120D	MRTSUE06648	1 year	2021/11/26	SIP-AC2
Horn Antenna	Schwarzbeck	BBHA 9120D	MRTSUE06648	1 year	2022/11/9	SIP-AC2
Anechoic Chamber	RIKEN	SIP-AC2	MRTSUE06781	1 year	2021/12/24	SIP-AC2

Software	Version	Function
EMI Software	V3	EMI Test Software

#### 4. MEASUREMENT UNCERTAINTY

Where relevant, the following test uncertainty levels have been estimated for tests performed on the EUT as specified in CISPR 16-4-2. This uncertainty represents an expanded uncertainty expressed at approximately the 95% confidence level using a coverage factor of  $k = 2$ .

<b>Radiated Spurious Emissions</b>
Measurement Uncertainty for a Level of Confidence of 95% ( $U=2Uc(y)$ ): Horizontal: 9kHz ~ 300MHz: 5.04dB 300MHz ~ 1GHz: 4.95dB 1GHz ~ 40GHz: 6.40dB Vertical: 9kHz ~ 300MHz: 5.24dB 300MHz ~ 1GHz: 6.03dB 1GHz ~ 40GHz: 6.40dB
<b>Conducted Spurious Emissions</b>
Measuring Uncertainty for a Level of Confidence of 95% ( $U=2Uc(y)$ ): 0.78dB
<b>Output Power</b>
Measuring Uncertainty for a Level of Confidence of 95% ( $U=2Uc(y)$ ): 1.13dB
<b>Occupied Bandwidth</b>
Measuring Uncertainty for a Level of Confidence of 95% ( $U=2Uc(y)$ ): 0.28%
<b>Frequency Stability</b>
Measuring Uncertainty for a Level of Confidence of 95% ( $U=2Uc(y)$ ): 76.2Hz

## 5. TEST RESULT

### 5.1. Summary

FCC Part Section(s)	Test Description	Test Limit	Test Condition	Test Result	Reference
2.1049	Occupied Bandwidth	N/A	Conducted	Pass	Section 5.2
2.1055, 27.54	Frequency Stability	Within the band		Pass	Section 5.3
27.50(a)(3)	Equivalent Radiated Power	< 250mW/5MHz		Pass	Section 5.4
2.1051, 27.53(a)(4)	Band Edge	Refer to section 5.5		Pass	Section 5.5
2.1051, 27.53(a)(4)	Spurious Emission	<70 + 10log10 (P <sub>[Watts]</sub> )		Pass	Section 5.6
2.1053, 27.53(a)(4)	Spurious Emission	<70 + 10log10 (P <sub>[Watts]</sub> )	Radiated	Pass	Section 5.7

#### Notes:

- 1) The analyzer plots shown in this section were all taken with a correction table loaded into the analyzer. The correction table was used to account for the losses of the cables and attenuators used as part of the system to connect the EUT to the analyzer at all frequencies of interest.
- 2) Pre-scan has been conducted to determine the worst-case mode from all possible combinations between available modulations the worst-case was found.
- 3) All supported modulation types were evaluated. The worst-case emission of modulation was selected. Therefore, the Frequency Stability, Band Edge, Radiated & Conducted Spurious Emission were presented worst case in the test report.

## 5.2. Occupied Bandwidth Measurement

### 5.2.1. Test Limit

The occupied bandwidth, that is the frequency bandwidth such that, below its lower and above its upper frequency limits, the mean powers radiated are each equal to 0.5 percent of the total mean power radiated by a given emission shall be measured.

### 5.2.2. Test Procedure

ANSI C63.26-2015 - Section 5.4

### 5.2.3. Test Setting

1. Set center frequency to the nominal EUT channel center frequency
2. RBW = The nominal RBW shall be in the range of 1% to 5% of the anticipated OBW
3. VBW  $\geq 3 \times$  RBW
4. Detector = Peak
5. Trace mode = max hold
6. Sweep = auto couple
7. Allow the trace to stabilize
8. Use the 99% power bandwidth function of the instrument and report the measured bandwidth.

### 5.2.4. Test Setup

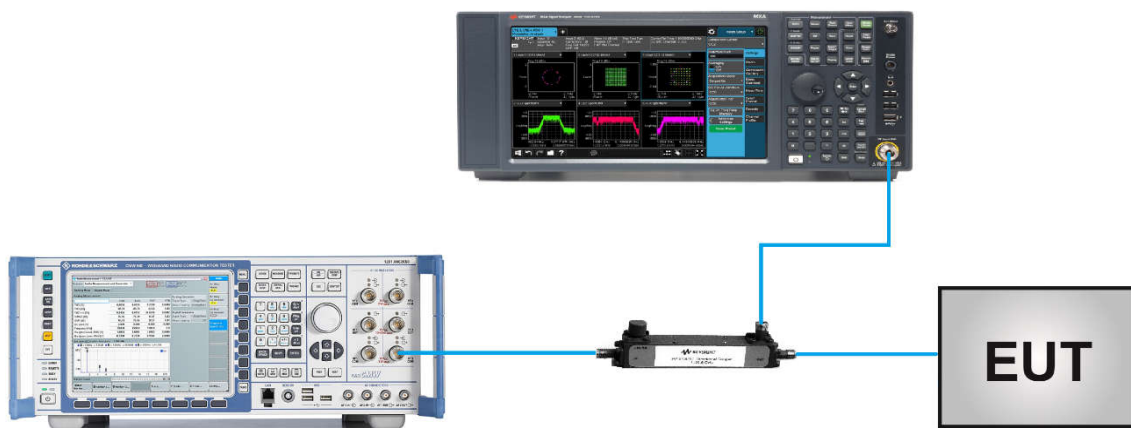

### 5.2.5. Test Result

Product	LTE Module	Test Site	SIP-SR1
Test Engineer	Candy Luo	Test Date	2021/11/05
Test Band	LTE Band 30		

Modulation	Frequency (MHz)	Bandwidth (MHz)	99% Bandwidth (MHz)
QPSK	2310	5	4.47
		10	8.96
16QAM	2310	5	4.48
		10	8.96

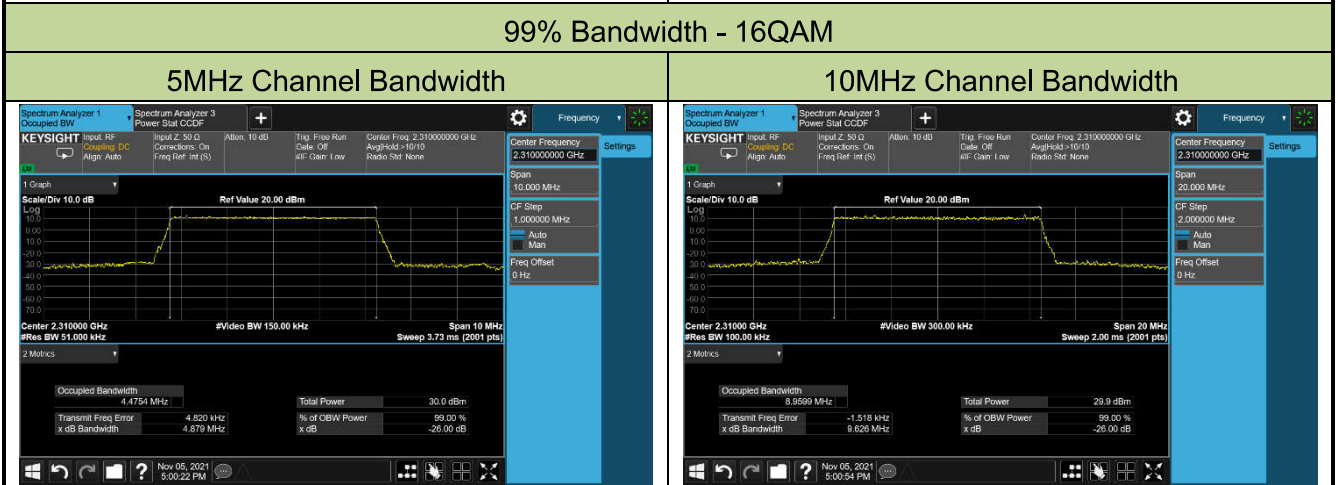
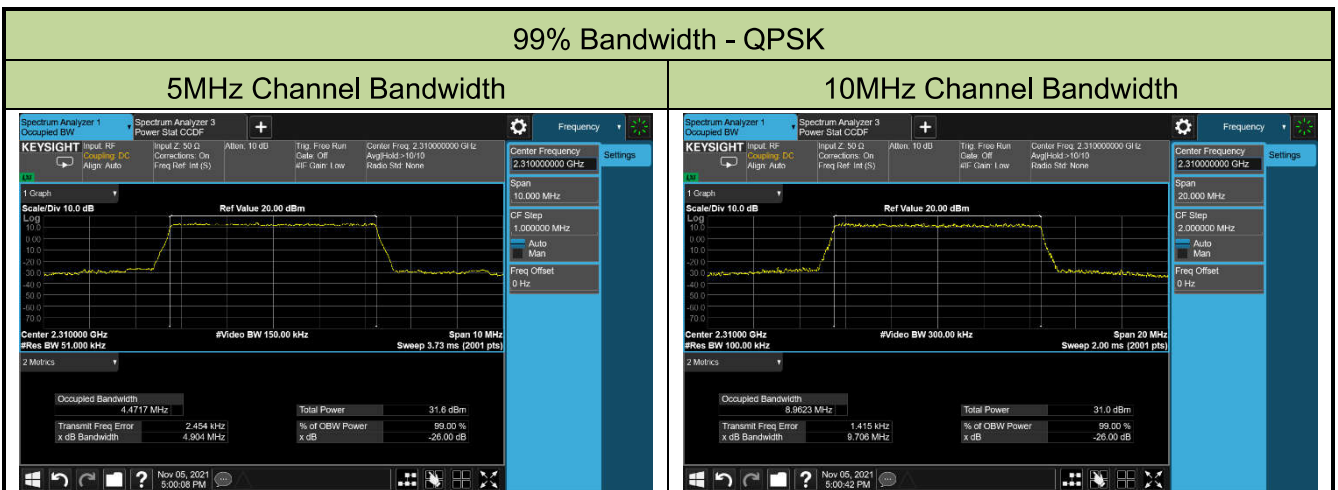

### **5.3. Frequency Stability Measurement**

#### **5.3.1. Test Limit**

The frequency stability shall be sufficient to ensure that the fundamental emissions stay within the authorized bands of operation.

#### **5.3.2. Test Procedure**

ANSI C63.26-2015 - Section 5.6

#### **5.3.3. Test Setting**

##### **Frequency Stability Under Temperature Variations:**

The equipment under test was connected to an external AC or DC power supply and input rated voltage. RF output was connected to a frequency counter or spectrum analyzer via feed through attenuators. The EUT was placed inside the temperature chamber. Set the spectrum analyzer RBW low enough to obtain the desired frequency resolution and measure EUT 20°C operating frequency as reference frequency. Turn EUT off and set the chamber temperature to highest. After the temperature stabilized for approximately 30 minutes recorded the frequency. Repeat step measure with 10°C decreased per stage until the lowest temperature reached.

##### **Frequency Stability Under Voltage Variations:**

Set chamber temperature to 20°C. Use a variable AC power supply / DC power source to power the EUT and set the voltage to rated voltage. Set the spectrum analyzer RBW low enough to obtain the desired frequency resolution and recorded the frequency.

Reduce the input voltage to specify extreme voltage variation ( $\pm 15\%$ ) and endpoint, record the maximum frequency change.

### 5.3.4. Test Setup

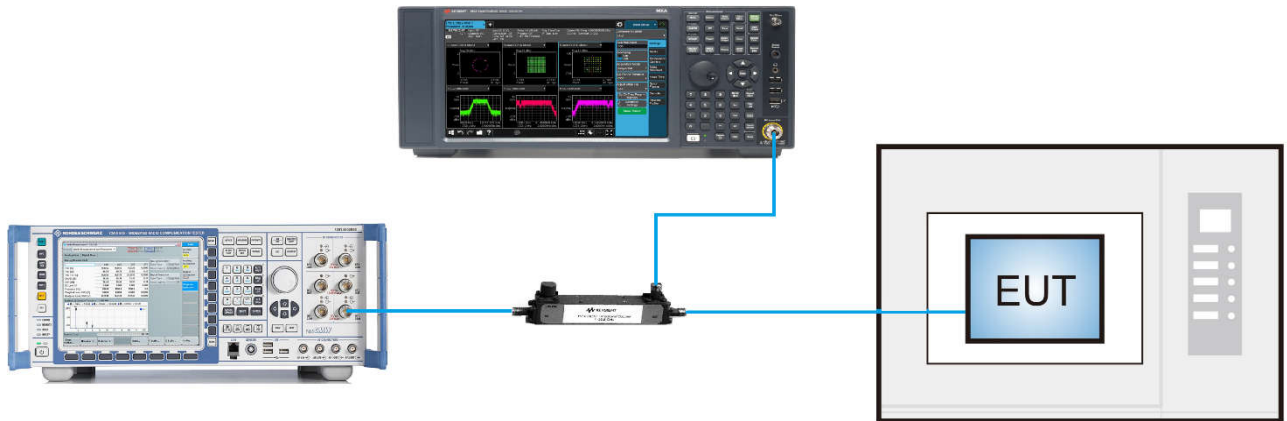

### 5.3.5.Test Result

Product	LTE Module	Test Site	SIP-SR1
Test Engineer	Candy Luo	Test Date	2021/11/11
Test Band	LTE Band 30		

Power (Vdc)	Temp. (°C)	Frequency Tolerance (ppm)
3.8	- 30	-0.0047
	- 20	-0.0056
	- 10	0.0065
	0	0.0044
	+ 10	-0.0054
	+ 20	0.0065
	+ 30	-0.0062
	+ 40	0.0057
	+ 50	-0.0038
4.4	+ 20	-0.0050
3.135	+ 20	0.0046



## **5.4. Equivalent Isotropically Radiated Power Measurement**

### **5.4.1. Test Limit**

For mobile and portable stations transmitting in the 2305-2315 MHz band or the 2350-2360 MHz band, the average EIRP must not exceed 50 milliwatts within any 1 megahertz of authorized bandwidth, except that for mobile and portable stations compliant with 3GPP LTE standards or another advanced mobile broadband protocol that avoids concentrating energy at the edge of the operating band the average EIRP must not exceed 250 milliwatts within any 5 megahertz of authorized bandwidth but may exceed 50 milliwatts within any 1 megahertz of authorized bandwidth

### **5.4.2. Test Procedure**

ANSI C63.26-2015 - Section 5.2.4.4.2 & 5.2.5.5

### **5.4.3. Test Setting**

When the fundamental condition for average power measurements cannot be realized (i.e., the EUT can not be configured to transmit at full-power on a continuous basis (i.e., duty cycle < 98%) and the instrumentation cannot be configured to measure only during active full-power transmissions), then the following procedure can be used if the EUT duty cycle is constant (i.e., duty cycle variations are less than or equal to  $\pm 2\%$ ).

- a) Set span to  $2 \times$  to  $3 \times$  the OBW.
  - b) Set RBW = 1% to 5% of the OBW.
  - c) Set VBW  $\geq 3 \times$  RBW.
  - d) Set number of measurement points in sweep  $\geq 2 \times$  span / RBW.
  - e) Sweep time:
    - 1) Set = auto-couple, or
    - 2) Set  $\geq [10 \times (\text{number of points in sweep}) \times (\text{transmission symbol period})]$  for single sweep (automation-compatible) measurement.
  - f) Detector = power averaging (rms).
  - g) Set sweep trigger to "free run."
  - h) Trace average at least 100 traces in power averaging (rms) mode if sweep is set to auto-couple.
- To accurately determine the average power over the on and off time of the transmitter, it can be necessary to increase the number of traces to be averaged above 100, or if using a manually configured sweep time, increase the sweep time.

i) Using the marker function to identify the maximum PSD.

j) Add  $10 \log (1/\text{duty cycle})$  to the measured power level to compute the average power during continuous transmission. For example, add  $[10 \log (1/0.25)] = 6 \text{ dB}$  if the duty cycle is a constant 25%.

The relevant equation for determining the maximum ERP or EIRP from the measured RF output power is given in Equation (1) as follows:

$$\text{ERP or EIRP} = P_{\text{Meas}} + G_{\text{T}} \quad (1)$$

where

ERP or EIRP effective radiated power or equivalent isotropically radiated power, respectively (expressed in the same units as  $P_{\text{Meas}}$ , e.g., dBm or dBW)

$P_{\text{Meas}}$  measured transmitter output power or PSD, in dBm or dBW

$G_{\text{T}}$  gain of the transmitting antenna, in dBd (ERP) or dBi (EIRP)

For devices utilizing multiple antennas, see 6.4 for guidance with respect to determining the effective array transmit antenna gain term to be used in the above equation.

#### 5.4.4. Test Setup

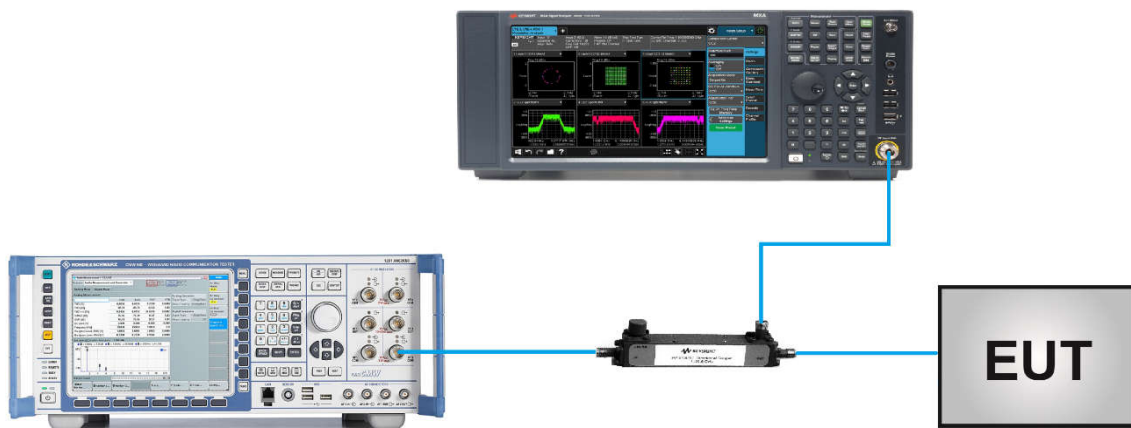

**5.4.5.Test Result**

Product	LTE Module	Test Site	SIP-SR1
Test Engineer	Candy Luo	Test Date	2021/11/11

Channel No.	Frequency (MHz)	Channel Bandwidth (MHz)	RB Size	RB Offset	Power Density (dBm/5MHz)	EIRP Density (dBm/5MHz)	Limit (dBm /5MHz)
<b>QPSK</b>							
27685	2307.5	5	25	0	21.29	21.96	< 23.98
27710	2310.0				21.31	21.98	< 23.98
27735	2312.5				21.21	21.88	< 23.98
27710	2310.0	10	50	0	19.02	19.69	< 23.98
<b>16QAM</b>							
27685	2307.5	5	25	0	20.31	20.98	< 23.98
27710	2310.0				20.37	21.04	< 23.98
27735	2312.5				20.20	20.87	< 23.98
27710	2310.0	10	50	0	18.08	18.75	< 23.98
Note: The EIRP Density (dBm/5MHz) = Power Density (dBm/5MHz) + Antenna Gain (dBi)							

## **5.5. Band Edge Measurement**

### **5.5.1. Test Limit**

For mobile and portable stations operating in the 2305-2315 MHz and 2350-2360MHz bands:

- (1) By a factor of not less than:  $43 + 10 \log (P)$  dB on all frequencies between 2305 and 2320 MHz and on all frequencies between 2345 and 2360 MHz that are outside the licensed band(s) of operation, not less than  $55 + 10 \log (P)$  dB on all frequencies between 2320 and 2324 MHz and on all frequencies between 2341 and 2345 MHz, not less than  $61 + 10 \log (P)$  dB on all frequencies between 2324 and 2328 MHz and on all frequencies between 2337 and 2341 MHz, and not less than  $67 + 10 \log (P)$  dB on all frequencies between 2328 and 2337 MHz;
- (2) By a factor of not less than  $43 + 10 \log (P)$  dB on all frequencies between 2300 and 2305 MHz,  $55 + 10 \log (P)$  dB on all frequencies between 2296 and 2300 MHz,  $61 + 10 \log (P)$  dB on all frequencies between 2292 and 2296 MHz,  $67 + 10 \log (P)$  dB on all frequencies between 2288 and 2292 MHz, and  $70 + 10 \log (P)$  dB below 2288 MHz;
- (3) By a factor of not less than  $43 + 10 \log (P)$  dB on all frequencies between 2360 and 2365 MHz, and not less than  $70 + 10 \log (P)$  dB above 2365 MHz.

### **5.5.2. Test Procedure**

ANSI C63.26-2015 - Section 5.7

### **5.5.3. Test Setting**

1. Set the analyzer frequency to low or high channel
2.  $RBW \geq$  The nominal RBW shall be in the range of 1% of the anticipated OBW (in the 1MHz band immediately outside and adjacent to the band edge). For improvement of the accuracy in the measurement of the average power of a noise-like emission, a RBW narrower than the specified reference bandwidth can be used (generally limited to no less than 1% of the OBW), provided that a subsequent integration is performed over the full required measurement bandwidth. This integration should be performed using the spectrum analyzer's band power functions.
3.  $VBW \geq 3 * RBW$
4. Sweep time = auto
5. Detector = power averaging (rms)
6. Set sweep trigger to "free run."
7. User gate triggered such that the analyzer only sweeps when the device is transmitting at full

power

- Trace average at least 100 traces in power averaging (rms) mode if sweep is set to auto-couple. To accurately determine the average power over the on and off time of the transmitter, it can be necessary to increase the number of traces to be averaged above 100, or if using a manually configured sweep time, increase the sweep time.

#### 5.5.4.Test Setup

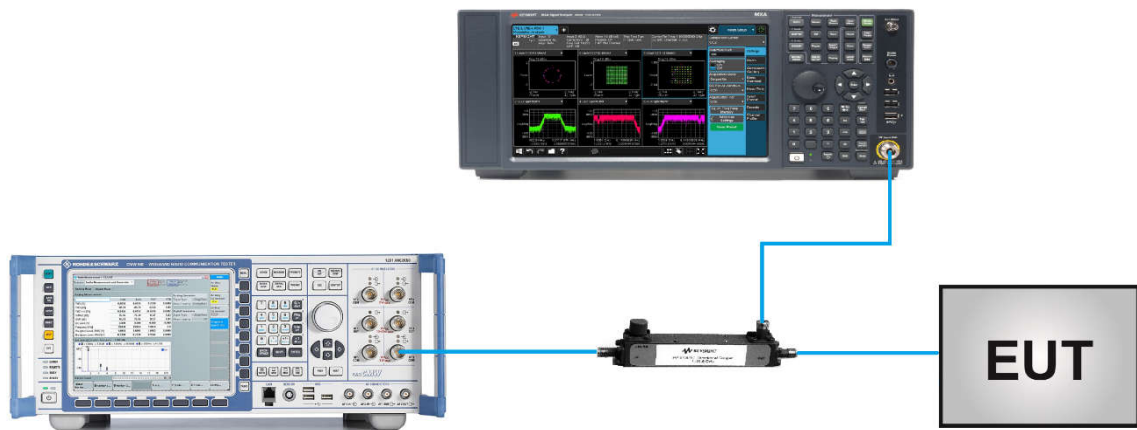

### 5.5.5.Test Result

Product	LTE Module	Test Site	SIP-SR1
Test Engineer	Candy Luo	Test Date	2021/11/18
Test Band	LTE Band 30_QPSK		

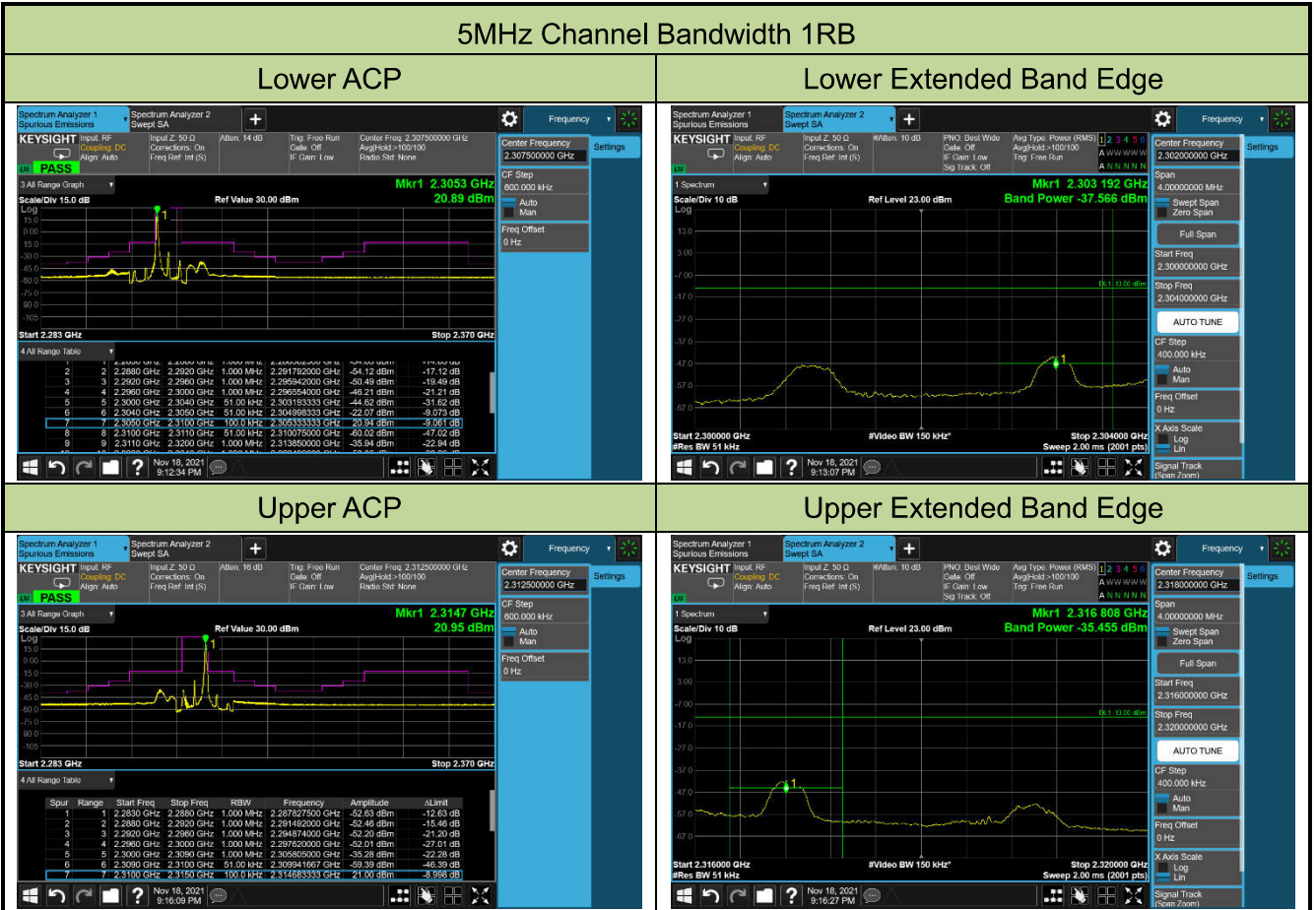

### 10MHz Channel Bandwidth 1RB

#### Lower ACP

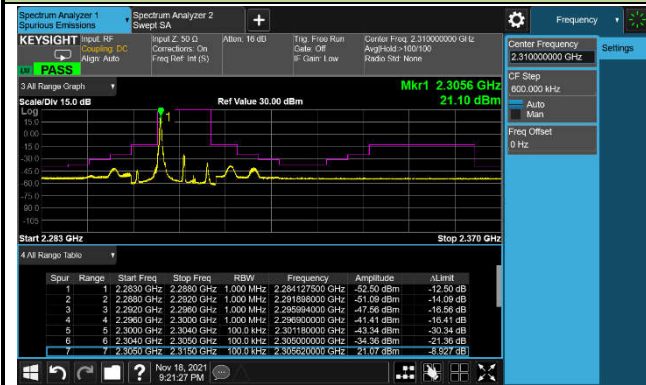

#### Lower Extended Band Edge

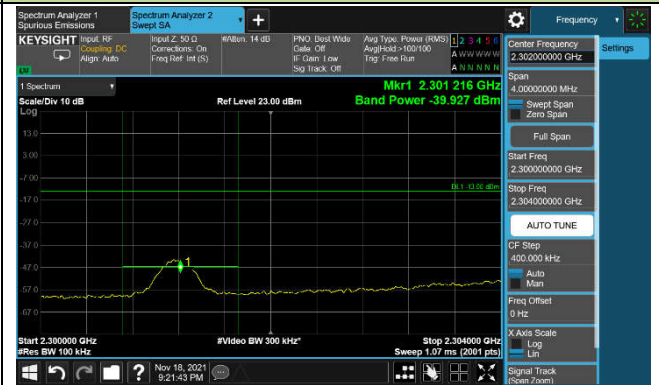

#### Upper ACP

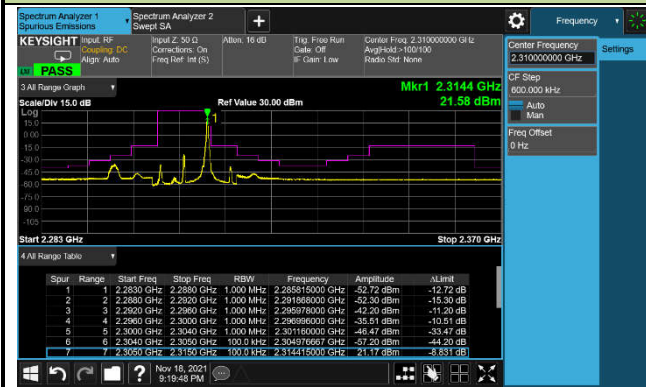

#### Upper Extended Band Edge

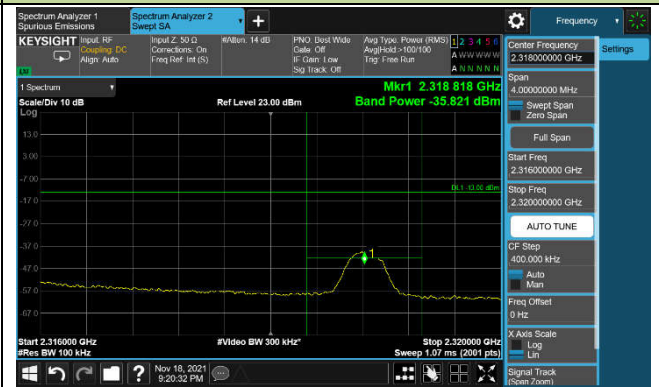

### 5MHz Channel Bandwidth Full RB

#### Lower ACP

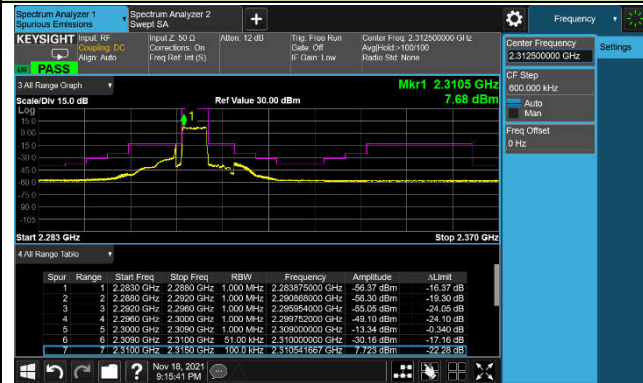

#### Lower Extended Band Edge



#### Upper ACP

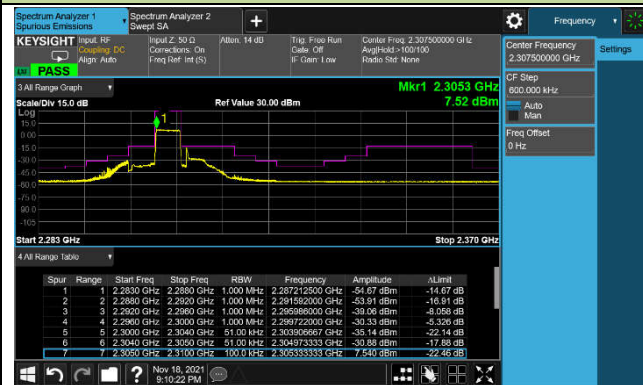

#### Upper Extended Band Edge

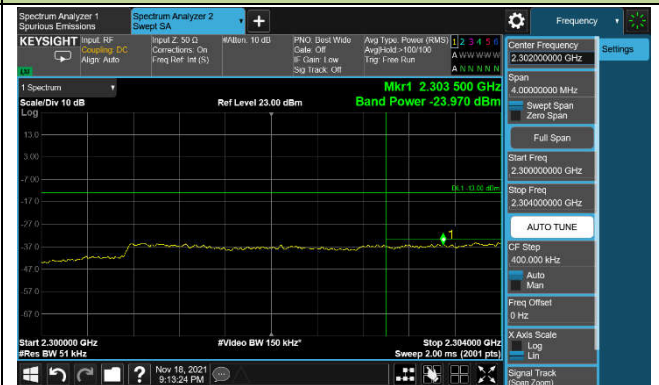

### 10MHz Channel Bandwidth Full RB

#### Lower ACP

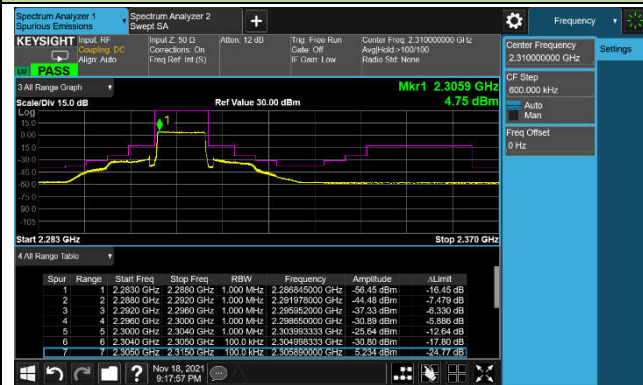

#### Upper ACP

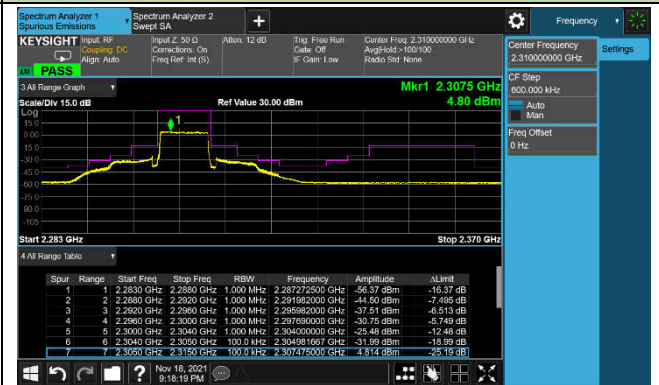



## **5.6. Conducted Spurious Emission Measurement**

### **5.6.1. Test Limit**

The level of the carrier and the various conducted spurious and harmonic frequencies is measured by means of a calibrated spectrum analyzer. The spectrum is scanned from the lowest frequency generated in the equipment up to a frequency including its 10<sup>th</sup> harmonic. All out of band emissions are measured with a spectrum analyzer connected to the antenna terminal of the EUT while the EUT is operating at its maximum duty cycle, at maximum power, and at the appropriate frequencies. All data rates were investigated to determine the worst-case configuration. All modes of operation were investigated and the worst-case configuration results are reported in this section.

The power of any emission outside of the authorized operating frequency ranges must be lower than the transmitter power (P) by a factor of at least  $70 + 10 \log (P)$  dB.

### **5.6.2. Test Procedure**

ANSI C63.26-2015 - Section 5.7

### **5.6.3. Test Setting**

1. Set the analyzer frequency to low, mid, high channel.
2. RBW = 1MHz
3. VBW  $\geq 3 \cdot$ RBW
4. Sweep time = auto
5. Detector = power averaging (rms)
6. Set sweep trigger to "free run."
7. User gate triggered such that the analyzer only sweeps when the device is transmitting at full power.
8. Trace average at least 100 traces in power averaging (rms) mode if sweep is set to auto-couple.  
To accurately determine the average power over the on and off time of the transmitter, it can be necessary to increase the number of traces to be averaged above 100, or if using a manually configured sweep time, increase the sweep time.

### 5.6.4.Test Setup



### 5.6.5.Test Result

Product	LTE Module	Test Site	SIP-SR1
Test Engineer	Candy Luo	Test Date	2021/11/26
Test Band	LTE Band 30_QPSK		

Channel	Frequency (MHz)	Channel Bandwidth (MHz)	Frequency Range (MHz)	Max Spurious Emissions (dBm)	Limit (dBm)	Result
27685	2307.5	5	30 ~ 25000	-43.04	≤ -40.00	Pass
27710	2310.0	5	30 ~ 25000	-44.03	≤ -40.00	Pass
27735	2312.5	5	30 ~ 25000	-44.33	≤ -40.00	Pass
27710	2310.0	10	30 ~ 25000	-44.87	≤ -40.00	Pass

Note: Spurious emissions within 9kHz – 30MHz were found more than 20dB below limit line.

### 5MHz Channel Bandwidth

#### Low Channel



#### Middle Channel

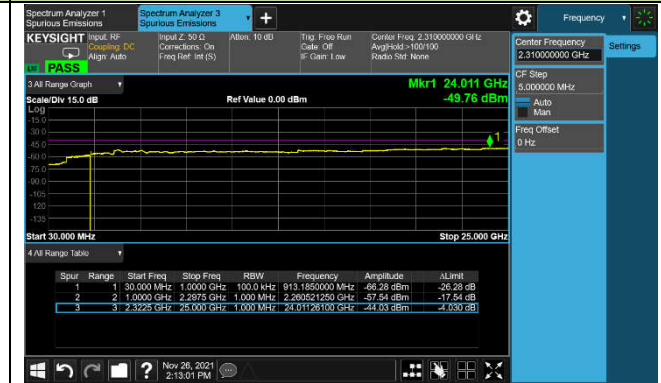

#### High Channel

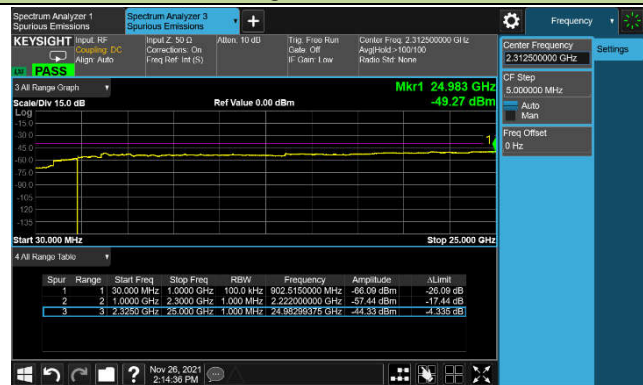

### 10MHz Channel Bandwidth

#### Middle Channel

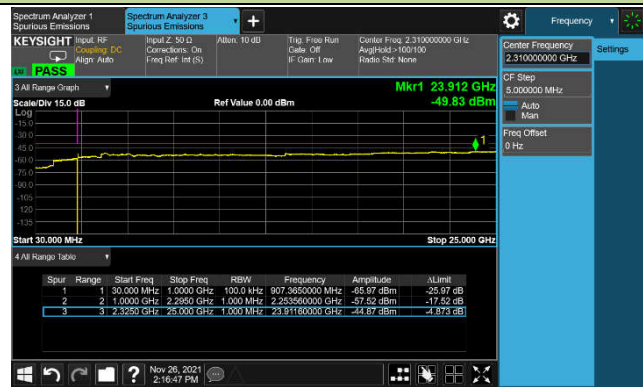

## 5.7. Radiated Spurious Emission Measurement

### 5.7.1. Test Limit

Out of band emissions: The power of any emission outside of the authorized operating frequency ranges must be lower than the transmitter power (P) by a factor of at least  $70 + 10 \log (P)$  dB.

$E \text{ (dB}\mu\text{V/m)} = \text{EIRP (dBm)} - 20 \log D + 104.8$ ; where D is the measurement distance in meters. The emission limit equal to 55.3dB $\mu\text{V/m}$ .

### 5.7.2. Test Procedure

ANSI C63.26-2015 - Section 5.2.7 & 5.5

### 5.7.3. Test Setting

1. RBW = 1MHz
2. VBW  $\geq 3 \times$  RBW
3. Sweep time  $\geq 10 \times$  (number of points in sweep)  $\times$  (transmission symbol period)
4. Detector = Peak
5. Trace mode = max hold
6. The trace was allowed to stabilize

### 5.7.4. Test Setup

Below 1GHz Test Setup:

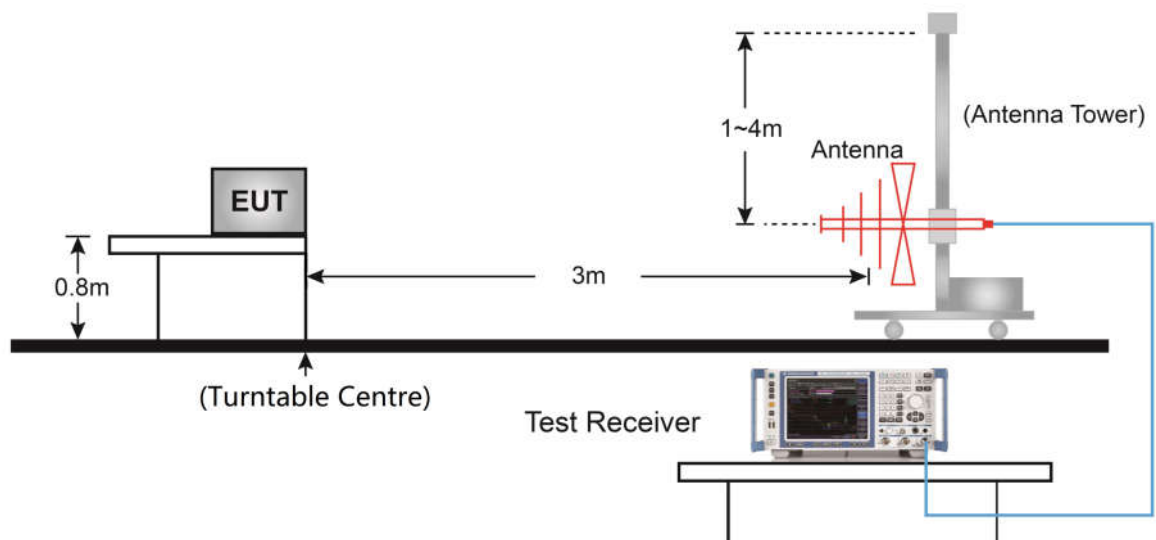

Above 1GHz Test Setup:

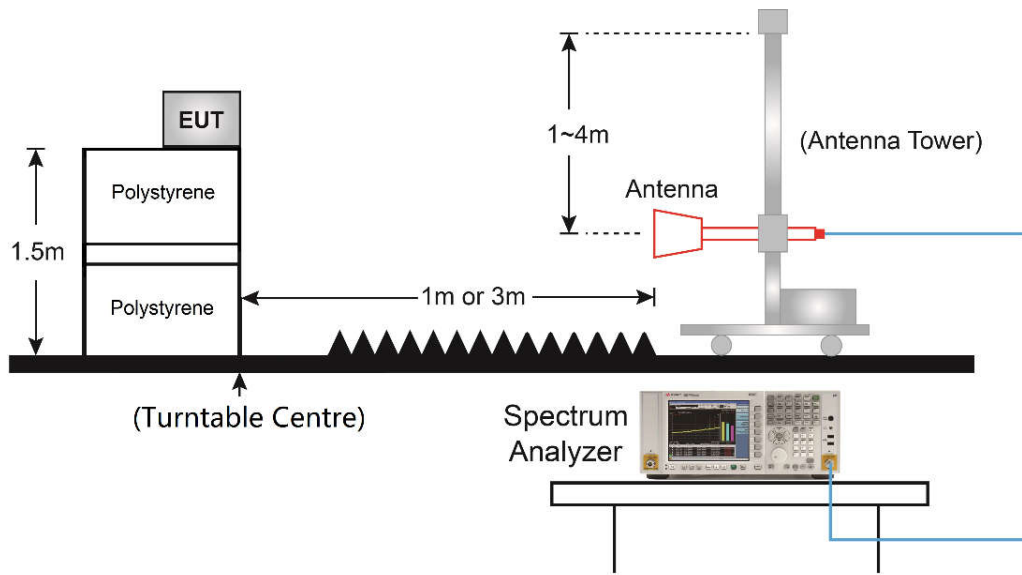

**5.7.5.Test Result**

Product	LTE Module	Test Site	SIP-AC2
Test Engineer	Allen Zou	Test Date	2021/11/12
Test Band	LTE Band 30_5MHz_1RB_QPSK		

Frequency (MHz)	Reading Level (dBμV)	Factor (dB/m)	Measure Level(dBμV/m)	Limit (dBμV/m)	Margin (dB)	Detector	Polarization
<b>Low Channel</b>							
69.77	20.93	15.60	36.53	55.30	-18.77	Peak	Horizontal
760.90	3.86	28.34	32.20	55.30	-23.10	Peak	Horizontal
30.00	18.70	16.37	35.07	55.30	-20.23	Peak	Vertical
67.35	19.59	16.10	35.69	55.30	-19.61	Peak	Vertical
16555.00	45.30	4.13	49.43	55.30	-5.87	Peak	Horizontal
17753.50	44.27	5.37	49.64	55.30	-5.66	Peak	Horizontal
16385.00	44.50	4.57	49.07	55.30	-6.23	Peak	Vertical
17753.50	44.22	5.37	49.59	55.30	-5.71	Peak	Vertical
<b>Middle Channel</b>							
69.77	18.18	15.60	33.78	55.30	-21.52	Peak	Horizontal
336.04	12.31	19.59	31.90	55.30	-23.40	Peak	Horizontal
30.00	19.19	16.37	35.56	55.30	-19.74	Peak	Vertical
67.35	19.45	16.10	35.55	55.30	-19.75	Peak	Vertical
16376.50	44.43	4.34	48.77	55.30	-6.53	Peak	Horizontal
17685.50	44.40	5.41	49.81	55.30	-5.49	Peak	Horizontal
15824.00	45.78	3.63	49.41	55.30	-5.89	Peak	Vertical
17915.00	45.20	5.36	50.56	55.30	-4.74	Peak	Vertical
<b>High Channel</b>							
69.77	18.00	15.60	33.60	55.30	-21.70	Peak	Horizontal
949.08	2.47	30.18	32.65	55.30	-22.65	Peak	Horizontal
30.00	18.48	16.37	34.85	55.30	-20.45	Peak	Vertical
67.35	19.71	16.10	35.81	55.30	-19.49	Peak	Vertical
16249.00	44.67	3.44	48.11	55.30	-7.19	Peak	Horizontal
17694.00	44.15	5.20	49.35	55.30	-5.95	Peak	Horizontal
16495.50	45.22	4.06	49.28	55.30	-6.02	Peak	Vertical
18000.00	44.07	5.63	49.70	55.30	-5.60	Peak	Vertical

Note: Measure Level (dBμV/m) = Reading Level (dBμV) + Factor (dB/m).

Factor (dB/m) = Cable Loss (dB) + Antenna Factor (dB/m)

## 6. CONCLUSION

The data collected relate only the item(s) tested and show that unitis compliance with FCC Rules.



## **Appendix A - Test Setup Photograph**

Refer to "2110RSU053-UT" file.

## **Appendix B - EUT Photograph**

Refer to "2110RSU053-UE" file.