



MEASUREMENT REPORT

FCC PART 90

FCC ID: ZMOFM101NA
Applicant: Fibocom Wireless Inc.

Application Type: Certification
Product: LTE Module
Model No.: FM101-NA
Brand Name: Fibocom
FCC Rule Part(s): Part 90 Subpart S
Test Procedure(s): ANSI C63.26: 2015
Test Date: November 05 ~ 26, 2021

Reviewed By: *Sunny Sun*

Approved By: *Robin Wu*



The test results relate only to the samples tested.

This equipment has been shown to be capable of compliance with the applicable technical standards as indicated in the measurement report and was tested in accordance with the measurement procedures specified in ANSI C63.26-2015. Test results reported herein relate only to the item(s) tested.

The test report shall not be reproduced except in full without the written approval of MRT Technology (Suzhou) Co., Ltd.

Revision History

Report No.	Version	Description	Issue Date	Note
2110RSU053-U4	Rev. 01	Initial Report	12-17-2021	Invalid
2110RSU053-U4	Rev. 02	Corrected the calibration date of equipment	12-23-2021	Valid

CONTENTS

Description	Page
1. GENERAL INFORMATION.....	5
1.1. Applicant.....	5
1.2. Manufacturer.....	5
1.3. Testing Facility.....	5
2. PRODUCT INFORMATION	6
2.1. Product Information	6
2.2. Radio Specification under Test	6
2.3. Description of Available Antennas.....	7
2.4. Test Methodology.....	7
2.5. EMI Suppression Device(s)/Modifications	7
2.6. Configuration of Tested System	8
2.7. Test Environment Condition.....	8
3. TEST EQUIPMENT CALIBRATION DATE.....	9
4. MEASUREMENT UNCERTAINTY.....	10
5. TEST RESULT	11
5.1. Summary	11
5.2. Occupied Bandwidth Measurement.....	12
5.2.1. Test Limit.....	12
5.2.2. Test Procedure.....	12
5.2.3. Test Setting	12
5.2.4. Test Setup.....	12
5.2.5. Test Result	13
5.3. Frequency Stability Measurement	16
5.3.1. Test Limit.....	16
5.3.2. Test Procedure.....	16
5.3.3. Test Setting	16
5.3.4. Test Setup.....	17
5.3.5. Test Result	18
5.4. Conducted Output Power Measurement	19
5.4.1. Test Limit.....	19
5.4.2. Test Procedure.....	19
5.4.3. Test Setting	19
5.4.4. Test Setup.....	19
5.4.5. Test Result	20

5.5.	Band Edge Measurement	24
5.5.1.	Test Limit.....	24
5.5.2.	Test Procedure	24
5.5.3.	Test Setting	24
5.5.4.	Test Setup	25
5.5.5.	Test Result	26
5.6.	Conducted Spurious Emission Measurement.....	30
5.6.1.	Test Limit.....	30
5.6.2.	Test Procedure	30
5.6.3.	Test Setting	30
5.6.4.	Test Setup	31
5.6.5.	Test Result	32
5.7.	Radiated Spurious Emission Measurement.....	36
5.7.1.	Test Limit.....	36
5.7.2.	Test Procedure.....	36
5.7.3.	Test Setting	36
5.7.4.	Test Setup	36
5.7.5.	Test Result	38
6.	CONCLUSION	39
	Appendix A - Test Setup Photograph	40
	Appendix B - EUT Photograph	41

1. GENERAL INFORMATION

1.1. Applicant

Fibocom Wireless Inc.

1101, Tower A, Building 6, Shenzhen International Innovation Valley, Dashi 1st Rd, Nanshan, Shenzhen, China

1.2. Manufacturer

Fibocom Wireless Inc.

1101, Tower A, Building 6, Shenzhen International Innovation Valley, Dashi 1st Rd, Nanshan, Shenzhen, China

1.3. Testing Facility

<input checked="" type="checkbox"/>	Test Site – MRT Suzhou Laboratory
	Laboratory Location (Suzhou – Wuzhong) D8 Building, No.2 Tian'edang Rd., Wuzhong Economic Development Zone, Suzhou, China
	Laboratory Location (Suzhou – SIP) 4b Building, Liando U Valley, No.200 Xingpu Rd., Shengpu Town, Suzhou Industrial Park, China
	Laboratory Accreditations
	A2LA: 3628.01 CNAS: L10551 FCC: CN1166 ISED: CN0001
	VCCI: <input type="checkbox"/> R-20025 <input type="checkbox"/> G-20034 <input type="checkbox"/> C-20020 <input type="checkbox"/> T-20020 <input type="checkbox"/> R-20141 <input type="checkbox"/> G-20134 <input type="checkbox"/> C-20103 <input type="checkbox"/> T-20104
<input type="checkbox"/>	Test Site – MRT Shenzhen Laboratory
	Laboratory Location (Shenzhen) 1G, Building A, Junxiangda Building, Zhongshanyuan Road West, Nanshan District, Shenzhen, China
	Laboratory Accreditations
	A2LA: 3628.02 CNAS: L10551 FCC: CN1284 ISED: CN0105
<input type="checkbox"/>	Test Site – MRT Taiwan Laboratory
	Laboratory Location (Taiwan) No. 38, Fuxing 2 nd Rd., Guishan Dist., Taoyuan City 333, Taiwan (R.O.C.)
	Laboratory Accreditations
	TAF: L3261-190725 FCC: 291082, TW3261 ISED: TW3261

2. PRODUCT INFORMATION

2.1. Product Information

Product Name	LTE Module
Model No.	FM101-NA
Brand Name	Fibocom
IMEI	Conducted Measurement: 867141050004112 Radiated Measurement: 867141050004062
Operating Temperature	-30 ~ 75 °C
Power Type	3.135 ~ 4.4Vdc, typical 3.8Vdc
Antenna Information	Refer to Section 2.3
UMTS Specification	
Single Band	Band 2, 4, 5
Modulation	Uplink up to 16QAM, Downlink up to 64QAM
E-UTRA Specification	
Single Band	Band 2, 4, 5, 7, 12, 13, 14, 17, 25, 26, 30, 41, 42, 43, 48, 66, 71
HPUE Band	Band 41
Modulation	Uplink up to 16QAM, Downlink up to 64QAM

Note: The information of EUT was provided by the manufacturer, and the accuracy of the information shall be the responsibility of the manufacturer.

2.2. Radio Specification under Test

FDD T _x Frequency Range	Band 26: 814 ~ 824 MHz
FDD R _x Frequency Range	Band 26: 859 ~ 869 MHz

Note 1: For other features of this EUT, test reports will be issued separately.

Note 2: LTE band 26 transmit frequency for part 90 rule is 814 ~ 824MHz and part 22 rule is 824 ~ 849MHz. ERP over 15MHz bandwidth complies the ERP limit line of part 22 rule, therefore ERP of the partial frequency spectrum which falls within part 22 also complies.

2.3. Description of Available Antennas

Technology	Frequency Range (MHz)	Antenna Type	Max Peak Gain (dBi)
LTE Band 2	1850 ~ 1910	PIFA	2.63
LTE Band 4	1710 ~ 1755		2.86
LTE Band 5	824 ~ 849		1.61
LTE Band 7	2500 ~ 2570		1.07
LTE Band 12	699 ~ 716		1.61
LTE Band 13	777 ~ 787		2.19
LTE Band 14	788 ~ 798		2.22
LTE Band 17	704 ~ 716		1.61
LTE Band 25	1850 ~ 1915		2.63
LTE Band 26	814 ~ 849		1.93
LTE Band 30	2305 ~ 2315		0.67
LTE Band 41	2496 ~ 2690		2.49
LTE Band 42	3450 ~ 3550		-1.18
LTE Band 42	3550 ~ 3600		-1.18
LTE Band 43	3600 ~ 3700		-0.13
LTE Band 43	3700 ~ 3800		-0.71
LTE Band 48	3550 ~ 3700		-0.13
LTE Band 66	1710 ~ 1780		3.76
LTE Band 71	663 ~ 698		1.39

2.4. Test Methodology

According to the specifications of the manufacturer, the EUT must comply with the requirements of the following standards:

- ANSI C63.26:2015
- FCC CFR 47 Part 90
- FCC KDB 971168 D01 v03r01: Power Meas License Digital Systems
- FCC KDB 971168 D02 v02r01: Misc Rev Approv License Devices
- FCC KDB 412172 D01 v01r01: Determining ERP and EIRP

2.5. EMI Suppression Device(s)/Modifications

No EMI suppression device(s) were added and/or no modifications were made during testing.

2.6. Configuration of Tested System

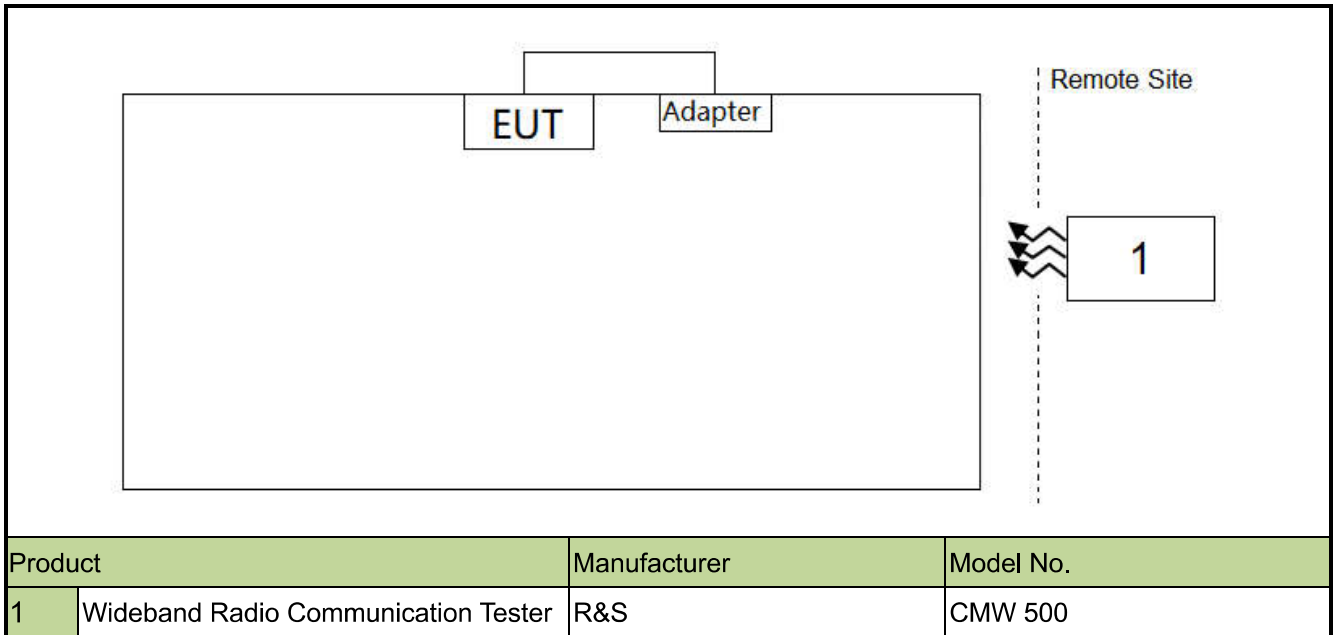

2.7. Test Environment Condition

Ambient Temperature	15 ~ 35°C
Relative Humidity	20% ~ 75%RH

3. TEST EQUIPMENT CALIBRATION DATE

Instrument Name	Manufacturer	Model No.	Asset No.	Cali. Interval	Cal. Due Date	Test Site
Communication Tester	R&S	CMU 200	MRTSUE06009	1 year	2022/9/7	SIP-SR1
Communication Tester	R&S	CMW500	MRTSUE06243	1 year	2022/10/10	SIP-SR1
Signal Generator	Keysight	E8257D	MRTSUE06453	1 year	2022/6/24	SIP-SR1
Thermohygrometer	testo	622	MRTSUE06629	1 year	2022/11/2	SIP-SR1
Signal Generator	Keysight	E8257D	MRTSUE06904	1 year	2021/12/8	SIP-SR1
Signal Generator	Keysight	E8257D	MRTSUE06904	1 year	2022/11/23	SIP-SR1
DC POWER MODULE	Keysight	N6743B	MRTSUE06905	/	/	SIP-SR1
DC POWER MODULE	Keysight	N6743B	MRTSUE06906	/	/	SIP-SR1
Low-Profile Modular Power System Mainframe	Keysight	N6700C	MRTSUE06907	/	/	SIP-SR1
Signal Analyzer	Keysight	N9021B	MRTSUE06915	1 year	2022/1/18	SIP-SR1
Temperature Chamber	BAOYT	BYG-80CL	MRTSUE06932	1 year	2022/3/16	SIP-SR1
Shielding Room	MIX-BEP	SIP-SR1	MRTSUE06948	/	/	SIP-SR1
EMI Test Receiver	R&S	ESR3	MRTSUE06185	1 year	2022/1/12	SIP-AC2
Signal Analyzer	Keysight	N9010B	MRTSUE06559	1 year	2022/6/24	SIP-AC2
Horn Antenna	Schwarzbeck	BBHA 9170	MRTSUE06599	1 year	2022/10/20	SIP-AC2
Preamplifier	EMCI	EMC184045SE	MRTSUE06602	1 year	2022/10/11	SIP-AC2
Thermohygrometer	testo	608-H1	MRTSUE06623	1 year	2021/12/3	SIP-AC2
Thermohygrometer	testo	608-H1	MRTSUE06624	1 year	2021/12/3	SIP-AC2
Preamplifier	EMCI	EMC051845SE	MRTSUE06644	1 year	2021/11/26	SIP-AC2
Preamplifier	EMCI	EMC051845SE	MRTSUE06644	1 year	2022/11/8	SIP-AC2
TRILOG Antenna	Schwarzbeck	VULB 9168	MRTSUE06647	1 year	2022/8/5	SIP-AC2
Horn Antenna	Schwarzbeck	BBHA 9120D	MRTSUE06648	1 year	2021/11/26	SIP-AC2
Horn Antenna	Schwarzbeck	BBHA 9120D	MRTSUE06648	1 year	2022/11/9	SIP-AC2
Anechoic Chamber	RIKEN	SIP-AC2	MRTSUE06781	1 year	2021/12/24	SIP-AC2

Software	Version	Function
EMI Software	V3	EMI Test Software

4. MEASUREMENT UNCERTAINTY

Where relevant, the following test uncertainty levels have been estimated for tests performed on the EUT as specified in CISPR 16-4-2. This uncertainty represents an expanded uncertainty expressed at approximately the 95% confidence level using a coverage factor of $k = 2$.

Radiated Spurious Emissions
Measurement Uncertainty for a Level of Confidence of 95% ($U=2Uc(y)$): Horizontal: 9kHz ~ 300MHz: 5.04dB 300MHz ~ 1GHz: 4.95dB 1GHz ~ 40GHz: 6.40dB Vertical: 9kHz ~ 300MHz: 5.24dB 300MHz ~ 1GHz: 6.03dB 1GHz ~ 40GHz: 6.40dB
Conducted Spurious Emissions
Measuring Uncertainty for a Level of Confidence of 95% ($U=2Uc(y)$): 0.78dB
Output Power
Measuring Uncertainty for a Level of Confidence of 95% ($U=2Uc(y)$): 1.13dB
Occupied Bandwidth
Measuring Uncertainty for a Level of Confidence of 95% ($U=2Uc(y)$): 0.28%
Frequency Stability
Measuring Uncertainty for a Level of Confidence of 95% ($U=2Uc(y)$): 76.2Hz

5. TEST RESULT

5.1. Summary

FCC Part Section(s)	Test Description	Test Limit	Test Condition	Test Result	Reference
2.1049	Occupied Bandwidth	N/A	Conducted	Pass	Section 5.2
2.1055, 90.213	Frequency Stability	< 2.5 ppm		Pass	Section 5.3
90.635	Conducted Output Power	< 100W		Pass	Section 5.4
2.1051, 90.691(a)	Band Edge	< 50 + 10log ₁₀ (P _[Watts]) within 37.5kHz of Block Edge		Pass	Section 5.5, 5.6
2.1051, 90.691(a)	Spurious Emission	< 43 + 10log ₁₀ (P _[Watts])			
2.1053, 90.691(a)	Spurious Emission	< 43 + 10log ₁₀ (P _[Watts])	Radiated	Pass	Section 5.7

Notes:

- 1) The analyzer plots shown in this section were all taken with a correction table loaded into the analyzer. The correction table was used to account for the losses of the cables and attenuators used as part of the system to connect the EUT to the analyzer at all frequencies of interest.
- 2) Pre-scan has been conducted to determine the worst-case mode from all possible combinations between available modulations the worst-case was found.
- 3) All supported modulation types were evaluated. The worst-case emission of modulation was selected. Therefore, the Frequency Stability, Band Edge, Radiated & Conducted Spurious Emission were presented worst case in the test report.

5.2. Occupied Bandwidth Measurement

5.2.1. Test Limit

The occupied bandwidth, that is the frequency bandwidth such that, below its lower and above its upper frequency limits, the mean powers radiated are each equal to 0.5 percent of the total mean power radiated by a given emission shall be measured.

5.2.2. Test Procedure

ANSI C63.26-2015 - Section 5.4

5.2.3. Test Setting

1. Set center frequency to the nominal EUT channel center frequency
2. RBW = The nominal RBW shall be in the range of 1% to 5% of the anticipated OBW
3. VBW $\geq 3 \times$ RBW
4. Detector = Peak
5. Trace mode = max hold
6. Sweep = auto couple
7. Allow the trace to stabilize
8. Use the 99% power bandwidth function of the instrument and report the measured bandwidth.

5.2.4. Test Setup

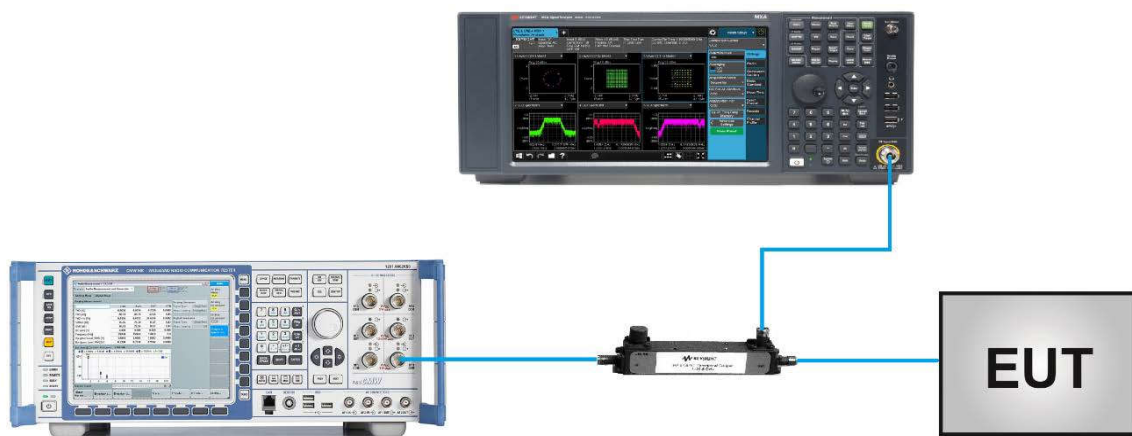

5.2.5.Test Result

Product	LTE Module	Test Site	SIP-SR1
Test Engineer	Candy Luo	Test Date	2021/11/05
Test Band	LTE Band 26		

Modulation	Frequency (MHz)	Bandwidth (MHz)	99% Bandwidth (MHz)
QPSK	819.0	1.4	1.08
		3	2.69
		5	4.48
		10	8.95
16QAM	819.0	1.4	1.08
		3	2.68
		5	4.47
		10	8.94
QPSK	821.5	15	13.4
16QAM			13.4

99% Bandwidth - QPSK

1.4MHz Channel Bandwidth



3MHz Channel Bandwidth

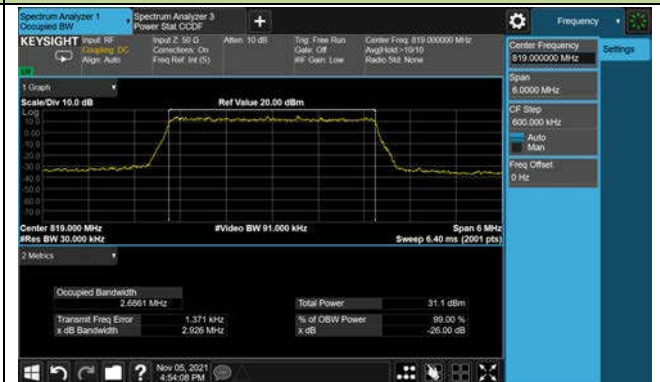

5MHz Channel Bandwidth

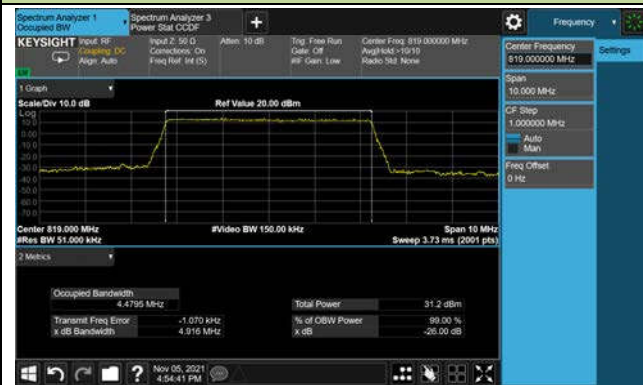

10MHz Channel Bandwidth

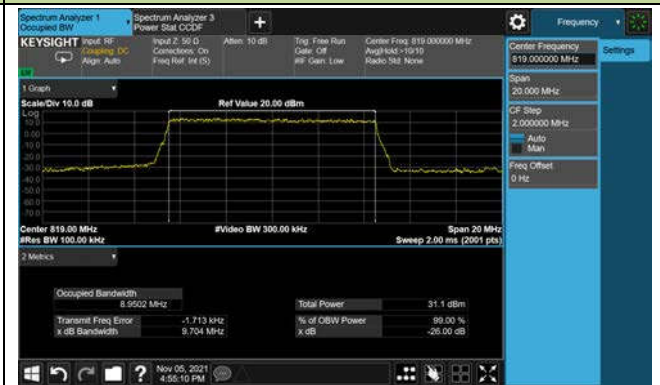

15MHz Channel Bandwidth

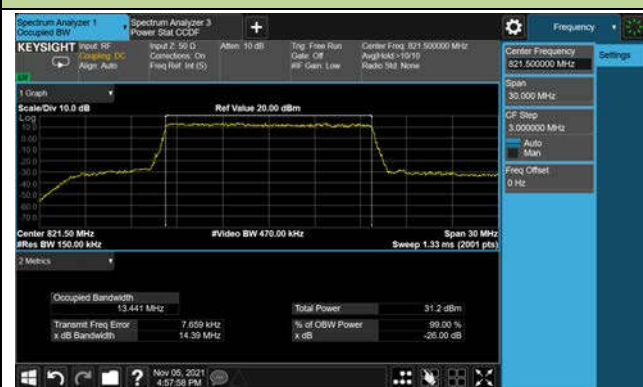

99% Bandwidth - 16QAM

1.4MHz Channel Bandwidth



3MHz Channel Bandwidth



5MHz Channel Bandwidth

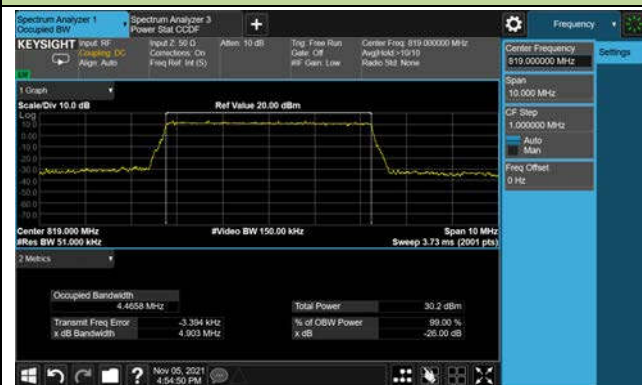

10MHz Channel Bandwidth

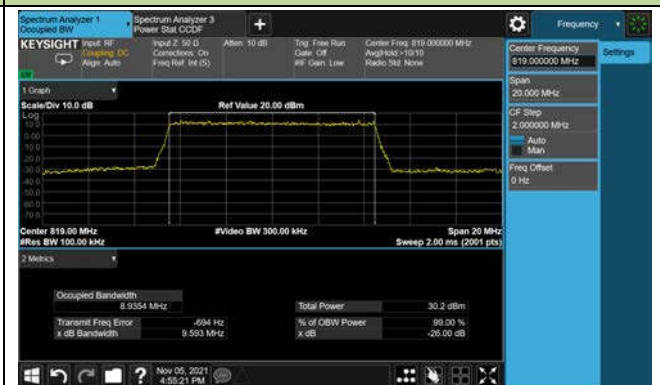

15MHz Channel Bandwidth

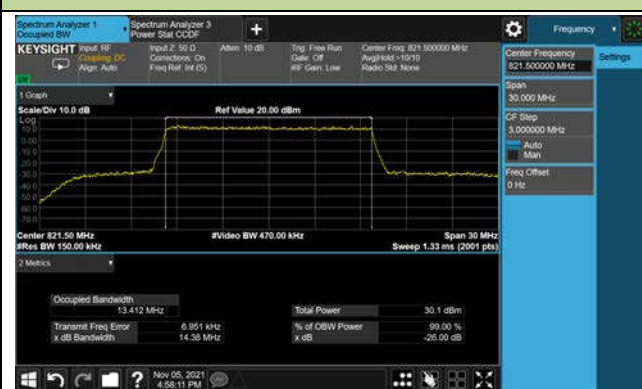

5.3. Frequency Stability Measurement

5.3.1. Test Limit

The frequency stability shall be measured by variation of ambient temperature and variation of primary supply voltage to ensure that the fundamental emission stays within the authorized frequency block. The frequency stability of the transmitter shall be maintained within $\pm 0.00025\%$ ($\pm 2.5\text{ppm}$) of the center frequency.

5.3.2. Test Procedure

ANSI C63.26-2015 - Section 5.6

5.3.3. Test Setting

Frequency Stability Under Temperature Variations:

The equipment under test was connected to an external AC or DC power supply and input rated voltage. RF output was connected to a frequency counter or spectrum analyzer via feed through attenuators. The EUT was placed inside the temperature chamber. Set the spectrum analyzer RBW low enough to obtain the desired frequency resolution and measure EUT 20°C operating frequency as reference frequency. Turn EUT off and set the chamber temperature to highest. After the temperature stabilized for approximately 30 minutes recorded the frequency. Repeat step measure with 10°C decreased per stage until the lowest temperature reached.

Frequency Stability Under Voltage Variations:

Set chamber temperature to 20°C. Use a variable AC power supply / DC power source to power the EUT and set the voltage to rated voltage. Set the spectrum analyzer RBW low enough to obtain the desired frequency resolution and recorded the frequency.

Reduce the input voltage to specify extreme voltage variation ($\pm 15\%$) and endpoint, record the maximum frequency change.

5.3.4.Test Setup

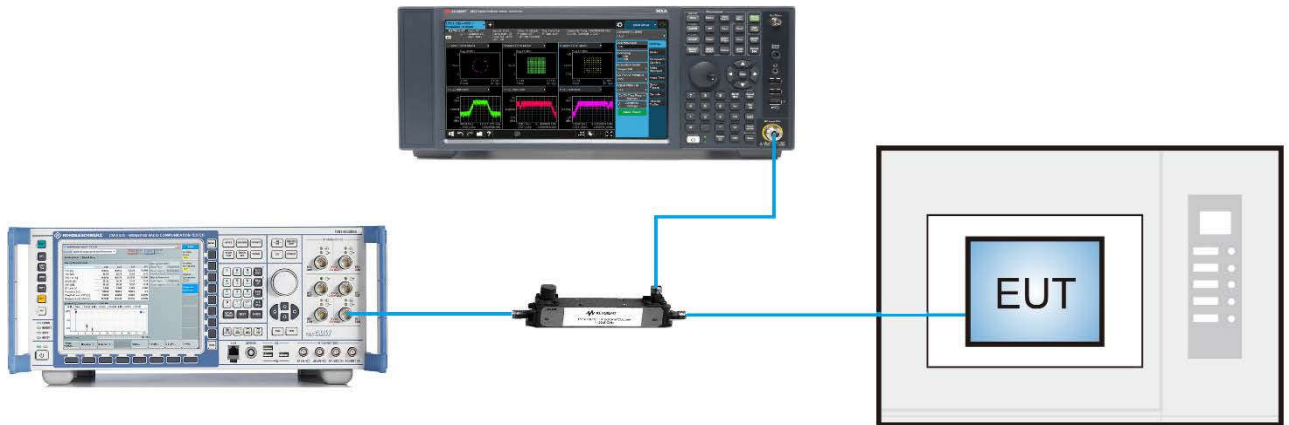

5.3.5.Test Result

Product	LTE Module	Test Site	SIP-R1
Test Engineer	Candy Luo	Test Date	2021/11/09
Test Band	LTE Band 26		

Power (Vdc)	Temp. (°C)	Frequency Tolerance (ppm)
3.8	- 30	-0.0123
	- 20	-0.0139
	- 10	-0.0132
	0	-0.0089
	+ 10	0.0050
	+ 20	-0.0090
	+ 30	-0.0113
	+ 40	-0.0113
	+ 50	-0.0057
4.4	+ 20	-0.0082
3.135	+ 20	-0.0104

5.4. Conducted Output Power Measurement

5.4.1. Test Limit

The maximum output power of the transmitter for mobile stations is 100 watts (20dBw).

5.4.2. Test Procedure

ANSI C63.26-2015 - Section 5.2

5.4.3. Test Setting

Average power measurements were performed only when the EUT was transmitting at its maximum power control level using a broadband power meter with a pulse sensor. The power meter implemented triggering and gating capabilities which were set up such that power measurements were recorded only during the ON time of the transmitter.

5.4.4. Test Setup



5.4.5.Test Result

Product	LTE Module	Test Site	SIP-SR1
Test Engineer	Candy Luo	Test Date	2021/11/22
Test Band	LTE Band 26		

Channel No.	Frequency (MHz)	Channel Bandwidth (MHz)	RB Size	RB Offset	Output Power (dBm)	Output Power (W)	Limit (W)
QPSK							
26697	814.7	1.4	1	0	22.70	0.1862	< 100
26740	819.0				22.62	0.1828	< 100
26783	823.3				22.72	0.1871	< 100
26697	814.7	1.4	1	2	22.64	0.1837	< 100
26740	819.0				22.71	0.1866	< 100
26783	823.3				22.73	0.1875	< 100
26697	814.7	1.4	1	6	22.66	0.1845	< 100
26740	819.0				22.61	0.1824	< 100
26783	823.3				22.74	0.1879	< 100
26697	814.7	1.4	6	0	21.72	0.1486	< 100
26740	819.0				21.71	0.1483	< 100
26783	823.3				21.77	0.1503	< 100
26705	815.5	3	1	0	22.67	0.1849	< 100
26740	819.0				22.70	0.1862	< 100
26775	822.5				22.84	0.1923	< 100
26705	815.5	3	1	7	22.70	0.1862	< 100
26740	819.0				22.70	0.1862	< 100
26775	822.5				22.79	0.1901	< 100
26705	815.5	3	1	14	22.68	0.1854	< 100
26740	819.0				22.82	0.1914	< 100
26775	822.5				22.77	0.1892	< 100
26705	815.5	3	15	0	21.76	0.1500	< 100
26740	819.0				21.86	0.1535	< 100
26775	822.5				21.86	0.1535	< 100

Channel No.	Frequency (MHz)	Channel Bandwidth (MHz)	RB Size	RB Offset	Output Power (dBm)	Output Power (W)	Limit (W)
QPSK							
26715	816.5	5	1	0	22.81	0.1910	< 100
26740	819.0				22.81	0.1910	< 100
26765	821.5				22.75	0.1884	< 100
26715	816.5	5	1	12	22.86	0.1932	< 100
26740	819.0				22.85	0.1928	< 100
26765	821.5				22.87	0.1936	< 100
26715	816.5	5	1	24	22.76	0.1888	< 100
26740	819.0				22.87	0.1936	< 100
26765	821.5				22.81	0.1910	< 100
26715	816.5	5	25	0	21.78	0.1507	< 100
26740	819.0				21.86	0.1535	< 100
26765	821.5				21.80	0.1514	< 100
26740	819.0	10	1	0	22.71	0.1866	< 100
			1	24	22.75	0.1884	< 100
			1	49	22.78	0.1897	< 100
			50	0	21.81	0.1517	< 100
26765	821.5	15	1	0	22.73	0.1875	< 100
			1	36	22.78	0.1897	< 100
			1	74	22.80	0.1905	< 100
			75	0	21.88	0.1542	< 100

Channel No.	Frequency (MHz)	Channel Bandwidth (MHz)	RB Size	RB Offset	Output Power (dBm)	Output Power (W)	Limit (W)
16QAM							
26697	814.7	1.4	1	0	21.70	0.1479	< 100
26740	819.0				21.42	0.1387	< 100
26783	823.3				21.59	0.1442	< 100
26697	814.7	1.4	1	2	21.78	0.1507	< 100
26740	819.0				21.39	0.1377	< 100
26783	823.3				21.63	0.1455	< 100
26697	814.7	1.4	1	6	21.70	0.1479	< 100
26740	819.0				21.42	0.1387	< 100
26783	823.3				21.60	0.1445	< 100
26697	814.7	1.4	6	0	20.60	0.1148	< 100
26740	819.0				20.76	0.1191	< 100
26783	823.3				20.81	0.1205	< 100
26705	815.5	3	1	0	21.77	0.1503	< 100
26740	819.0				21.52	0.1419	< 100
26775	822.5				22.19	0.1656	< 100
26705	815.5	3	1	7	22.07	0.1611	< 100
26740	819.0				21.84	0.1528	< 100
26775	822.5				22.14	0.1637	< 100
26705	815.5	3	1	14	21.82	0.1521	< 100
26740	819.0				22.13	0.1633	< 100
26775	822.5				21.50	0.1413	< 100
26705	815.5	3	15	0	20.77	0.1194	< 100
26740	819.0				20.87	0.1222	< 100
26775	822.5				20.79	0.1199	< 100

Channel No.	Frequency (MHz)	Channel Bandwidth (MHz)	RB Size	RB Offset	Output Power (dBm)	Output Power (W)	Limit (W)
16QAM							
26715	816.5	5	1	0	22.01	0.1589	< 100
26740	819.0				21.47	0.1403	< 100
26765	821.5				21.75	0.1496	< 100
26715	816.5	5	1	12	21.51	0.1416	< 100
26740	819.0				22.20	0.1660	< 100
26765	821.5				21.99	0.1581	< 100
26715	816.5	5	1	24	21.41	0.1384	< 100
26740	819.0				22.19	0.1656	< 100
26765	821.5				21.83	0.1524	< 100
26715	816.5	5	25	0	20.76	0.1191	< 100
26740	819.0				20.74	0.1186	< 100
26765	821.5				20.84	0.1213	< 100
26740	819.0	10	1	0	22.21	0.1663	< 100
			1	24	22.16	0.1644	< 100
			1	49	22.14	0.1637	< 100
			50	0	20.90	0.1230	< 100
26765	821.5	15	1	0	21.78	0.1507	< 100
			1	36	21.88	0.1542	< 100
			1	74	22.00	0.1585	< 100
			75	0	20.85	0.1216	< 100

5.5. Band Edge Measurement

5.5.1. Test Limit

Out-of-band emission requirement shall apply only to the “outer” channels included in an EA license and to spectrum adjacent to interior channels used by incumbent licensees. The emission limits are as follows:

(1) For any frequency removed from the EA licensee's frequency block by up to and including 37.5 kHz, the power of any emission shall be attenuated below the transmitter power (P) in watts by at least $116 \text{ Log}(f/6.1)$ decibels or $50 + 10 \text{ Log}(P)$ decibels or 80 decibels, whichever is the lesser attenuation, where f is the frequency removed from the center of the outer channel in the block in kilohertz and where f is greater than 12.5 kHz.

(2) For any frequency removed from the EA licensee's frequency block greater than 37.5 kHz, the power of any emission shall be attenuated below the transmitter power (P) in watts by at least $43 + 10 \text{ Log}_{10}(P)$ decibels or 80 decibels, whichever is the lesser attenuation, where f is the frequency removed from the center of the outer channel in the block in kilohertz and where f is greater than 37.5 kHz.

5.5.2. Test Procedure

ANSI C63.26-2015 - Section 5.7

5.5.3. Test Setting

1. Set the analyzer frequency to low or high channel
2. $\text{RBW} \geq$ The nominal RBW shall be in the range of 1% of the anticipated OBW (in the 1MHz band immediately outside and adjacent to the band edge). For improvement of the accuracy in the measurement of the average power of a noise-like emission, a RBW narrower than the specified reference bandwidth can be used (generally limited to no less than 1% of the OBW), provided that a subsequent integration is performed over the full required measurement bandwidth. This integration should be performed using the spectrum analyzer's band power functions.
3. $\text{VBW} \geq 3 * \text{RBW}$
4. Sweep time = auto
5. Detector = power averaging (rms)
6. Set sweep trigger to “free run.”
7. User gate triggered such that the analyzer only sweeps when the device is transmitting at full

power

- Trace average at least 100 traces in power averaging (rms) mode if sweep is set to auto-couple. To accurately determine the average power over the on and off time of the transmitter, it can be necessary to increase the number of traces to be averaged above 100, or if using a manually configured sweep time, increase the sweep time.

5.5.4.Test Setup

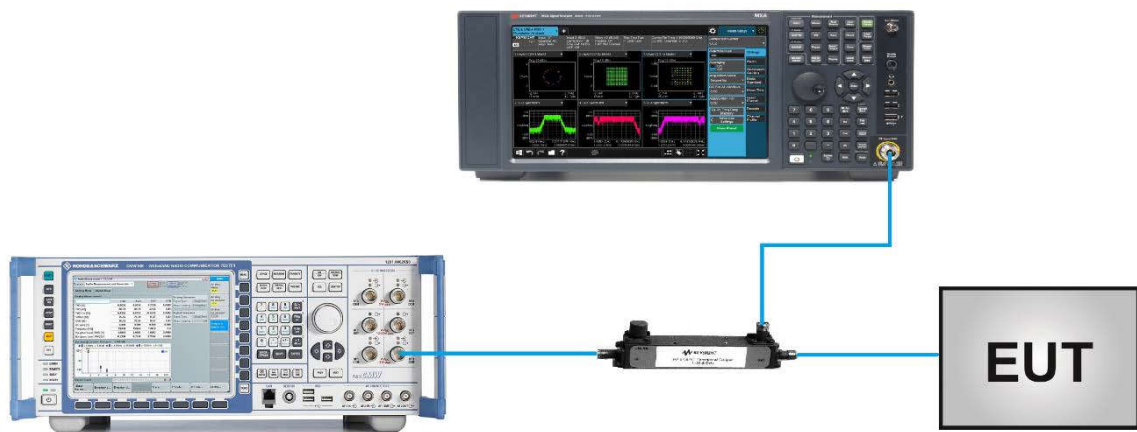

5.5.5.Test Result

Product	LTE Module	Test Site	SIP-SR1
Test Engineer	Candy Luo	Test Date	2021/11/17 ~ 2021/11/26
Test Band	LTE Band 26_QPSK		

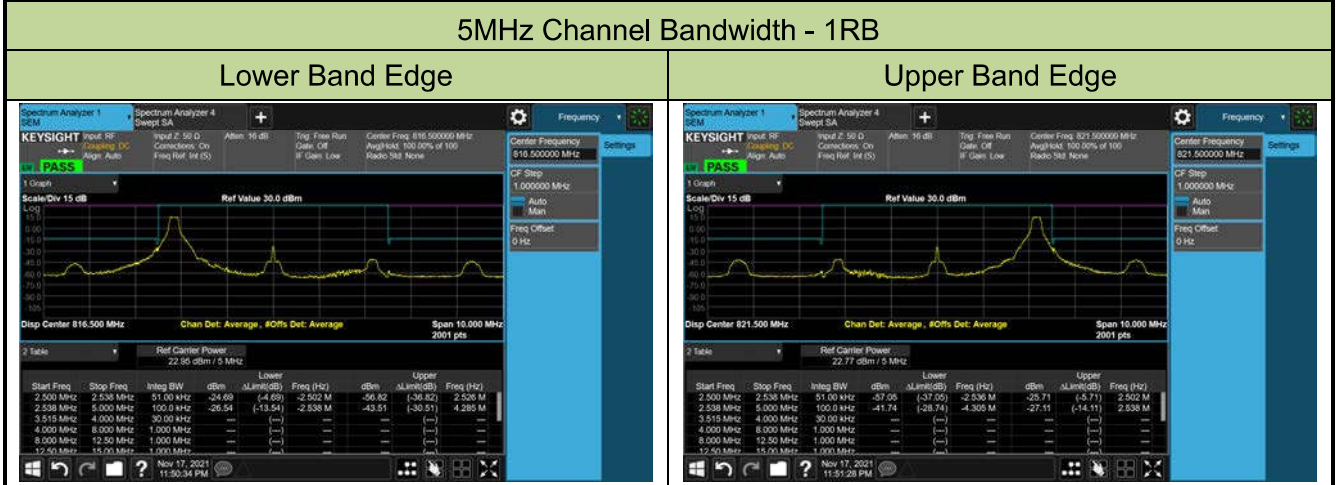
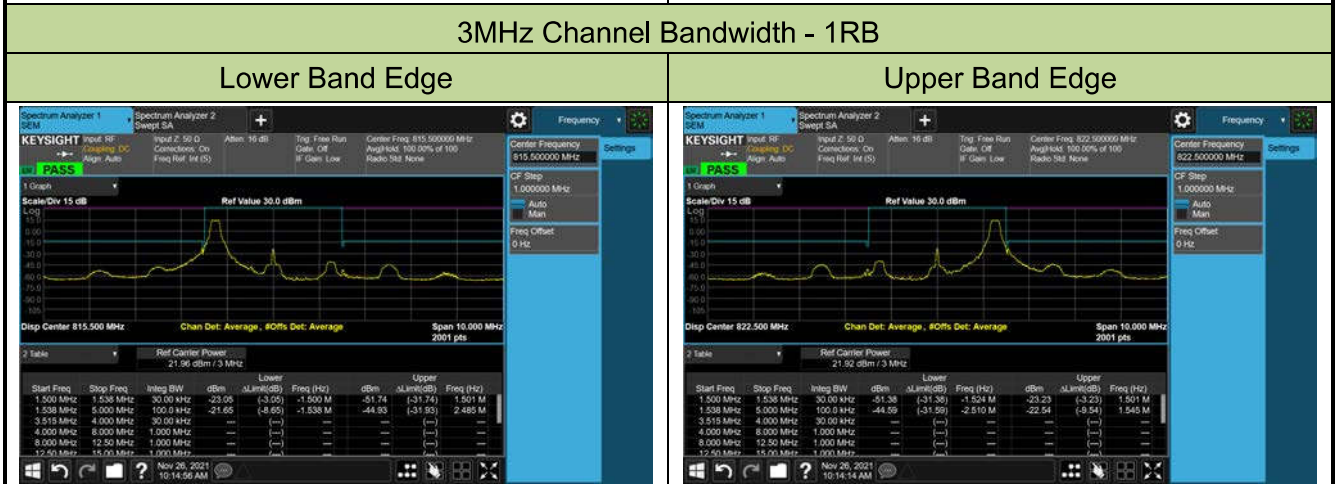
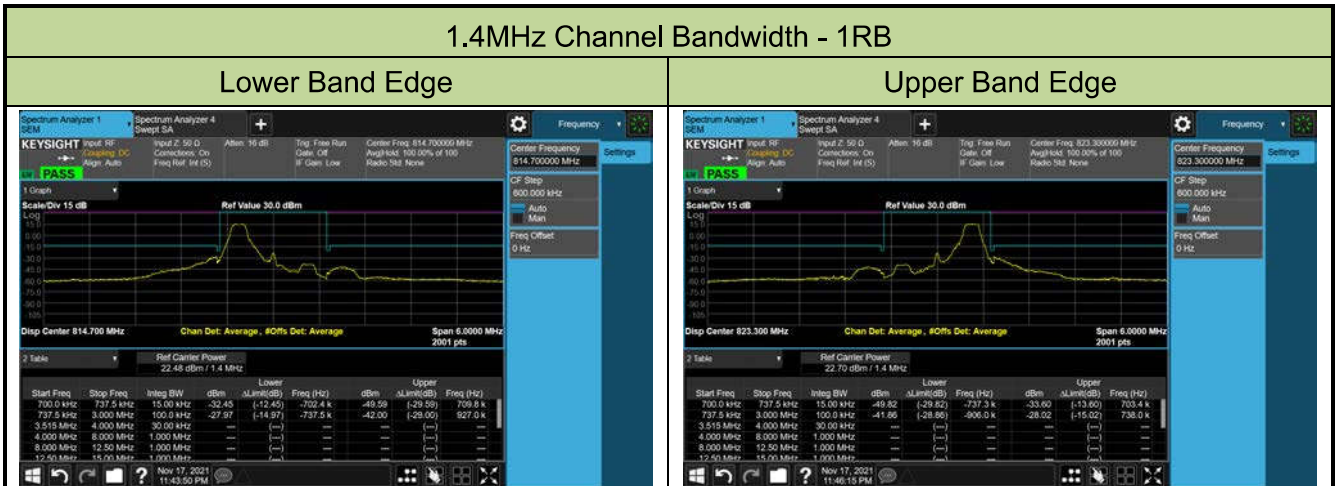

10MHz Channel Bandwidth - 1RB

Lower Band Edge



Upper Band Edge



15MHz Channel Bandwidth - 1RB

Lower Band Edge



Upper Band Edge



1.4MHz Channel Bandwidth - Full RB

Lower Band Edge



Upper Band Edge



3MHz Channel Bandwidth - Full RB

Lower Band Edge

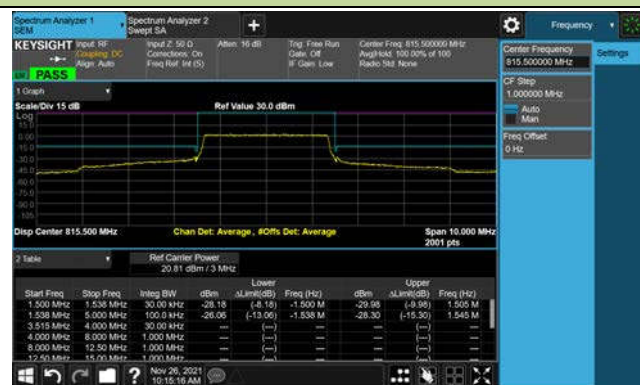

Upper Band Edge



5MHz Channel Bandwidth - Full RB

Lower Band Edge

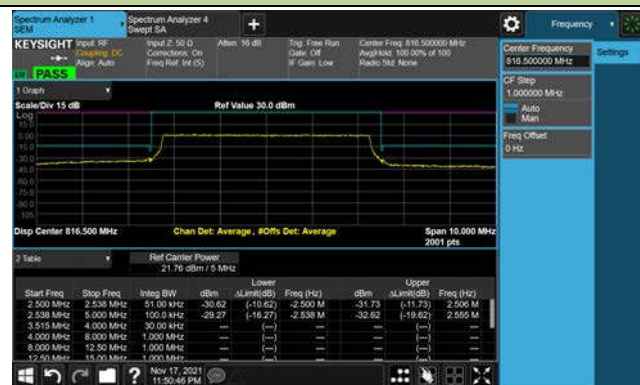

Upper Band Edge



10MHz Channel Bandwidth - Full RB

Band Edge



15MHz Channel Bandwidth - Full RB

Band Edge

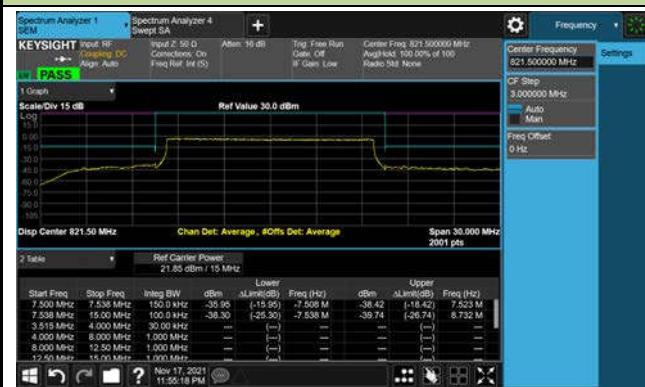

5.6. Conducted Spurious Emission Measurement

5.6.1. Test Limit

The level of the carrier and the various conducted spurious and harmonic frequencies is measured by means of a calibrated spectrum analyzer. The spectrum is scanned from the lowest frequency generated in the equipment up to a frequency including its 10th harmonic. All out of band emissions are measured with a spectrum analyzer connected to the antenna terminal of the EUT while the EUT is operating at its maximum duty cycle, at maximum power, and at the appropriate frequencies. All data rates were investigated to determine the worst-case configuration. All modes of operation were investigated, and the worst-case configuration results are reported in this section.

For any frequency removed from the EA licensee's frequency block greater than 37.5 kHz, the power of any emission shall be attenuated below the transmitter power (P) in watts by at least $43 + 10\text{Log}_{10}(P)$ decibels or 80 decibels, whichever is the lesser attenuation, where f is the frequency removed from the center of the outer channel in the block in kilohertz and where f is greater than 37.5 kHz.

5.6.2. Test Procedure

ANSI C63.26-2015 - Section 5.7

5.6.3. Test Setting

1. Set the analyzer frequency to low, mid, high channel.
2. RBW = 1MHz
3. VBW \geq 3*RBW
4. Sweep time = auto
5. Detector = power averaging (rms)
6. Set sweep trigger to "free run."
7. User gate triggered such that the analyzer only sweeps when the device is transmitting at full power.
8. Trace average at least 100 traces in power averaging (rms) mode if sweep is set to auto-couple. To accurately determine the average power over the on and off time of the transmitter, it can be necessary to increase the number of traces to be averaged above 100, or if using a manually configured sweep time, increase the sweep time.

5.6.4.Test Setup



5.6.5.Test Result

Product	LTE Module	Test Site	SIP-SR1
Test Engineer	Candy Luo	Test Date	2021/11/16
Test Band	LTE Band 26_QPSK		

Channel	Frequency (MHz)	Channel Bandwidth (MHz)	Frequency Range (MHz)	Max Spurious Emissions (dBm)	Limit (dBm)	Result
26697	814.7	1.4	30 ~ 9000	-37.54	≤ -13.00	Pass
26740	819.0	1.4	30 ~ 9000	-37.64	≤ -13.00	Pass
26783	823.3	1.4	30 ~ 9000	-37.56	≤ -13.00	Pass
26705	815.5	3	30 ~ 9000	-37.09	≤ -13.00	Pass
26740	819.0	3	30 ~ 9000	-37.53	≤ -13.00	Pass
26775	822.5	3	30 ~ 9000	-37.61	≤ -13.00	Pass
26715	816.5	5	30 ~ 9000	-37.75	≤ -13.00	Pass
26740	819.0	5	30 ~ 9000	-36.08	≤ -13.00	Pass
26765	821.5	5	30 ~ 9000	-37.89	≤ -13.00	Pass
26740	819.0	10	30 ~ 9000	-34.42	≤ -13.00	Pass
26745	821.5	15	30 ~ 9000	-34.71	≤ -13.00	Pass

Note: Spurious emissions within 9kHz – 30MHz were found more than 20dB below limit line.

1.4MHz Channel Bandwidth

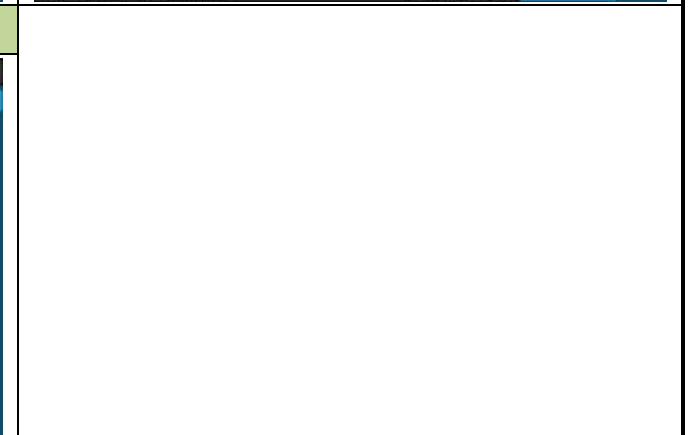

3MHz Channel Bandwidth

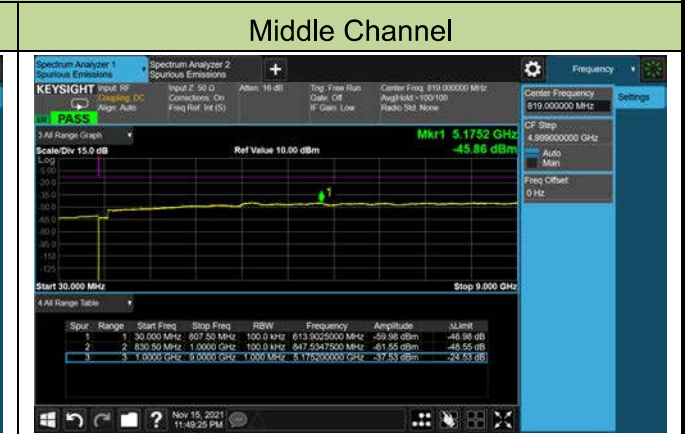

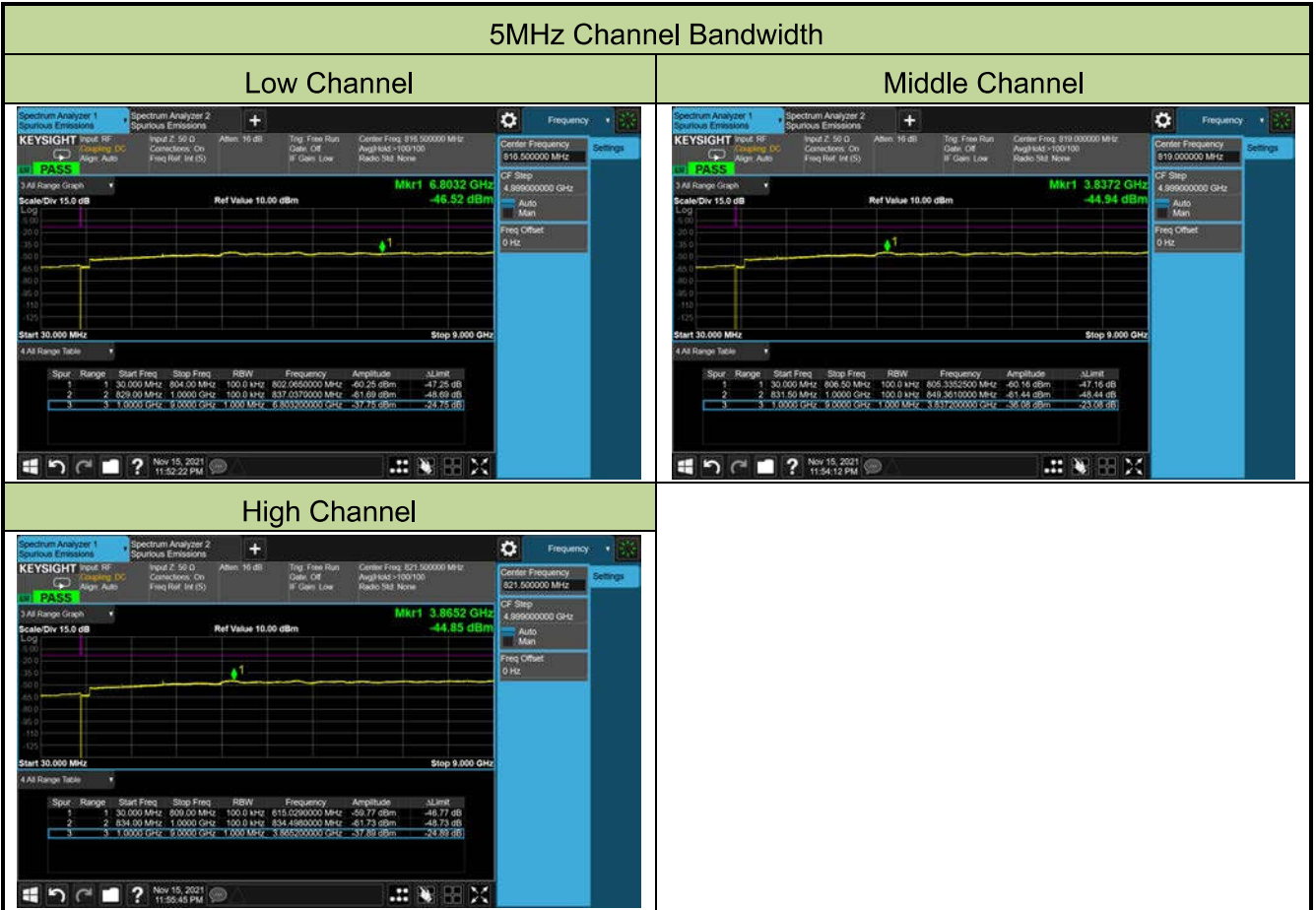

10MHz Channel Bandwidth

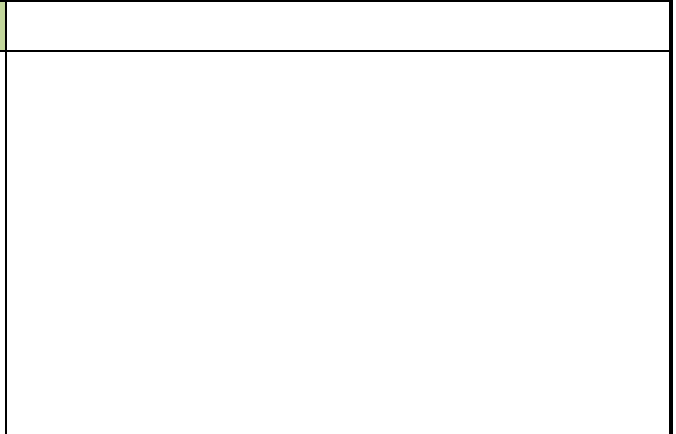

15MHz Channel Bandwidth

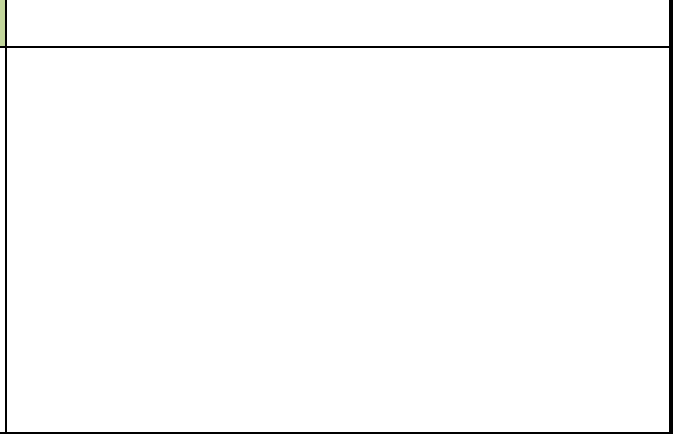
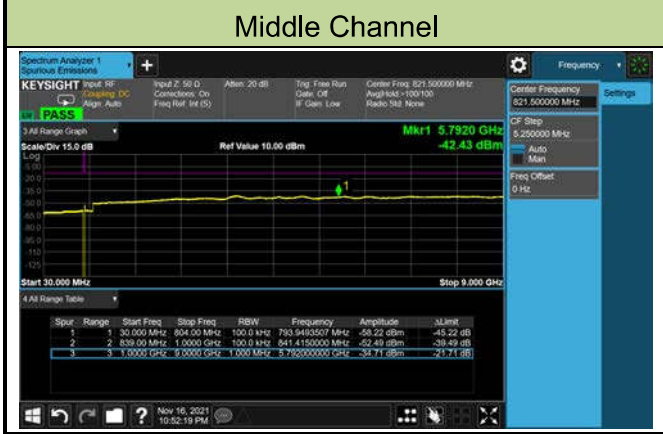

5.7. Radiated Spurious Emission Measurement

5.7.1. Test Limit

Out of band emissions: The power of any emission outside of the authorized operating frequency ranges must be attenuated below the transmitting power (P) by a factor of at least $43 + 10 \log(P)$ dB. The emission limit equal to -13dBm.

E (dB μ V/m) = EIRP (dBm) - 20 log D + 104.8; where D is the measurement distance in meters. The emission limit equal to 82.3dB μ V/m.

5.7.2. Test Procedure

ANSI C63.26-2015 - Section 5.2.7 & 5.5

5.7.3. Test Setting

1. RBW = 1MHz
2. VBW $\geq 3 \times$ RBW
3. Sweep time $\geq 10 \times$ (number of points in sweep) \times (transmission symbol period)
4. Detector = Peak
5. Trace mode = max hold
6. The trace was allowed to stabilize

5.7.4. Test Setup

Below 1GHz Test Setup:

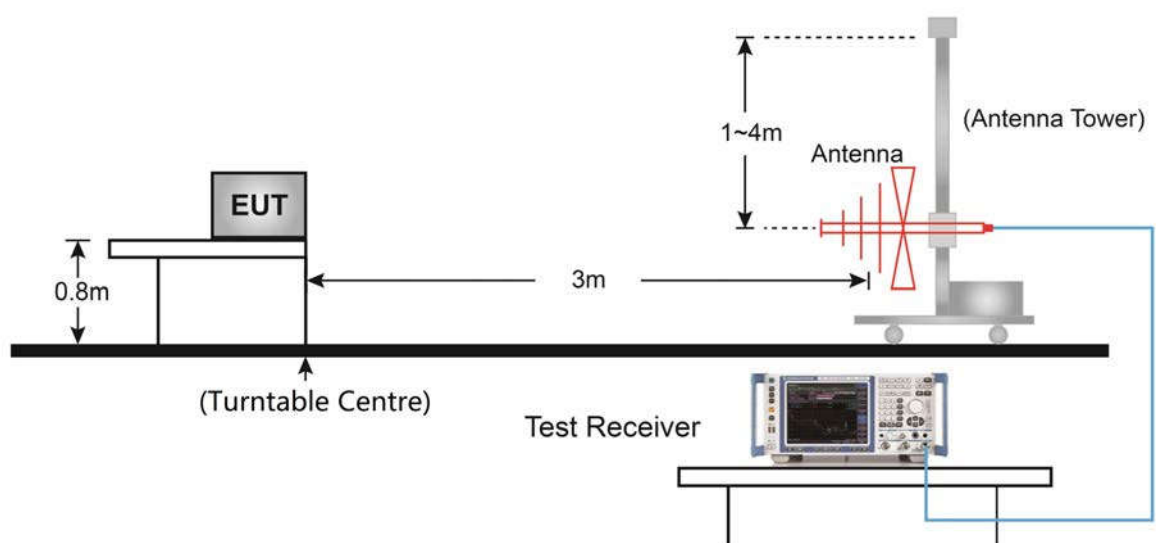

Above 1GHz Test Setup:

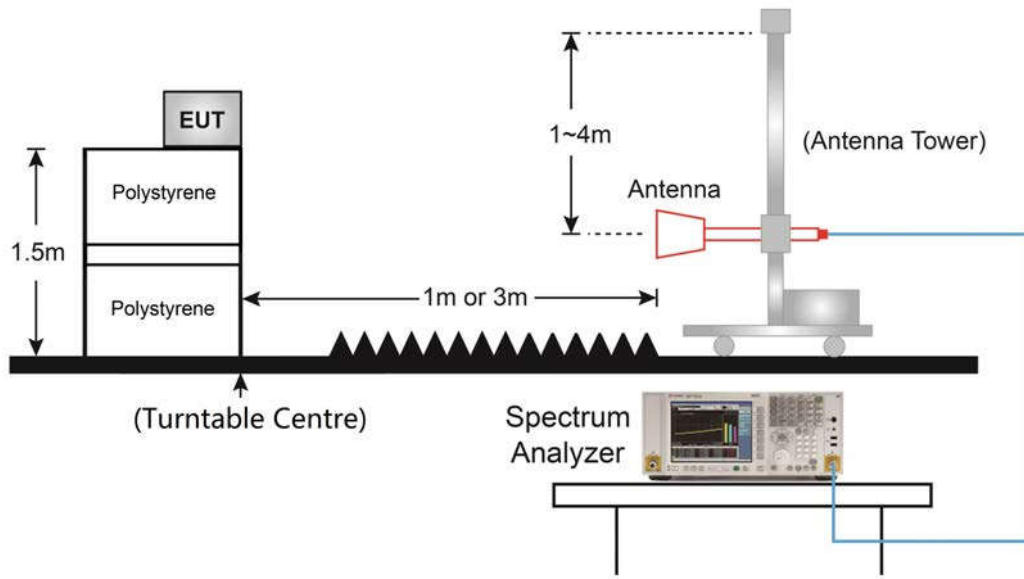

5.7.5.Test Result

Product	LTE Module	Test Site	SIP-AC2
Test Engineer	Allen Zou	Test Date	2021/11/12
Test Band	LTE Band 26_1.4MHz_1RB_QPSK		

Frequency (MHz)	Reading Level (dBμV)	Factor (dB/m)	Measure Level(dBμV/m)	Limit (dBμV/m)	Margin (dB)	Detector	Polarization
Low Channel							
780.78	22.23	28.32	50.55	82.30	-31.75	Peak	Horizontal
958.29	22.47	30.11	52.58	82.30	-29.72	Peak	Horizontal
678.45	22.98	26.56	49.54	82.30	-32.76	Peak	Vertical
939.86	22.67	30.05	52.72	82.30	-29.58	Peak	Vertical
16147.00	44.79	4.05	48.84	82.30	-33.46	Peak	Horizontal
17422.00	45.33	4.69	50.02	82.30	-32.28	Peak	Horizontal
15756.00	44.89	3.35	48.24	82.30	-34.06	Peak	Vertical
17541.00	44.46	5.09	49.55	82.30	-32.75	Peak	Vertical
Middle Channel							
773.51	22.36	28.38	50.74	82.30	-31.56	Peak	Horizontal
963.63	22.56	30.00	52.56	82.30	-29.74	Peak	Horizontal
775.93	22.01	28.35	50.36	82.30	-31.94	Peak	Vertical
941.80	21.44	30.07	51.51	82.30	-30.79	Peak	Vertical
13852.00	47.06	0.54	47.60	82.30	-34.70	Peak	Horizontal
16453.00	45.98	4.26	50.24	82.30	-32.06	Peak	Horizontal
14812.50	44.70	2.47	47.17	82.30	-35.13	Peak	Vertical
16461.50	46.05	4.43	50.48	82.30	-31.82	Peak	Vertical
High Channel							
754.11	22.22	28.16	50.38	82.30	-31.92	Peak	Horizontal
958.78	22.04	30.09	52.13	82.30	-30.17	Peak	Horizontal
761.87	21.49	28.36	49.85	82.30	-32.45	Peak	Vertical
950.53	22.38	30.17	52.55	82.30	-29.75	Peak	Vertical
14183.50	46.15	1.29	47.44	82.30	-34.86	Peak	Horizontal
17906.50	45.83	5.27	51.10	82.30	-31.20	Peak	Horizontal
14498.00	45.62	1.76	47.38	82.30	-34.92	Peak	Vertical
16393.50	45.13	4.44	49.57	82.30	-32.73	Peak	Vertical

Note: Measure Level (dBμV/m) = Reading Level (dBμV) + Factor (dB/m).

Factor (dB/m) = Cable Loss (dB) + Antenna Factor (dB/m)

6. CONCLUSION

The data collected relate only the item(s) tested and show that unit is compliance with FCC Rules.

Appendix A - Test Setup Photograph

Refer to "2110RSU053-UT" file.

Appendix B - EUT Photograph

Refer to "2110RSU053-UE" file.