



Prüfbericht-Nr.: <i>Test report no.:</i>	ULR- TC568820300000037F	Auftrags-Nr.: <i>Order no.:</i>	166203252 0030 Seite 1 von 45 Page 1 of 45	
Kunden-Referenz-Nr.: <i>Client reference no.:</i>	NA	Auftragsdatum: <i>Order date:</i>	2019-11-26	
Auftraggeber: <i>Client:</i>	Mistral Solutions Private Limited 60 Adarsh Regent, 100 feet ring road Domlur Extension, Bangalore-560071,India			
Prüfgegenstand: <i>Test item:</i>	SD820 Nano SOM with 2x2 802.11 a/b/g/n/ac WIFI+ Bluetooth Module			
Bezeichnung / Serien -Nr.: <i>Identification / Serial no.:</i>	SD820 Nano SOM Rev B			
Auftrags-Inhalt: <i>Order content:</i>	Testing & issue of test report			
Prüfgrundlage: <i>Test specification:</i>	FCC Part 15 Subpart C 15.247, 15.207, RSS 247 Issue 2 and RSS Gen Issue 5			
Wareneingangsdatum: <i>Date of sample receipt:</i>	2020-03-10			
Prüfmuster-Nr.: <i>Test sample no.:</i>	A001073243-001 A001073243-002			
Prüfzeitraum: <i>Testing period:</i>	2020-08-24 - 2020-08-28			
Ort der Prüfung: <i>Place of testing:</i>	Wireless laboratory, Bangalore			
Prüflaboratorium: <i>Testing laboratory:</i>	TÜV Rheinland (India) Pvt.Ltd., 27/B, 2nd Cross, ElectronicCityPhase1 Bangalore – 560 100, India			
Prüfergebnis*: <i>Test result*:</i>	Pass			
geprüft von: <i>tested by:</i>				genehmigt von: <i>authorized by:</i>
Datum: <i>Date:</i>	2020-11-28	Ausstellatum: <i>Issue date:</i>	2020-11-28	
Stellung / Position:	Madhu Karadekere Nagaraju Senior Engineer	Stellung / Position:	Mahammadgouse Kaladagi Assistant Manager	
Sonstiges / Other:	ULR – TC5688-20300000037F FCC ID: 2AVEC-QCNFA324 IC ID: 26058-QCNFA324			
Zustand des Prüfgegenstandes bei Anlieferung: <i>Condition of the test item at delivery:</i>	Prüfmuster vollständig und unbeschädigt Test item complete and undamaged			
* Legende:	1 = sehr gut P(ass) = entspricht o.g. Prüfgrundlage(n)	2 = gut F(ail) = entspricht nicht o.g. Prüfgrundlage(n)	3 = befriedigend N/A = nicht anwendbar N/T = nicht getestet	4 = ausreichend N/A = nicht anwendbar N/T = nicht getestet
* Legend:	1 = very good P(ass) = passed a.m. test specification(s)	2 = good F(ail) = failed a.m. test specification(s)	3 = satisfactory N/A = not applicable N/T = not tested	4 = sufficient N/A = not applicable N/T = not tested
<p>Dieser Prüfbericht bezieht sich nur auf das o.g. Prüfmuster und darf ohne Genehmigung der Prüfstelle nicht auszugsweise vervielfältigt werden. Dieser Bericht berechtigt nicht zur Verwendung eines Prüfzeichens. <i>This test report only relates to the a. m. test sample. Without permission of the test center this test report is not permitted to be duplicated in extracts. This test report does not entitle to carry any test mark.</i></p>				

Prüfbericht - Nr.:
Test Report No.:

ULR-TC568820300000037F

Seite 2 von 45
Page 2 of 45

TEST SUMMARY

Test Item	Applicable Standard		Result
	FCC	ISED	
Maximum conducted (average) output power	FCC 15.247(b)(3)	RSS 247 Issue 2, Section 5.4 (d)	*N/T
Maximum Power Spectral Density	FCC 15.247(e)	RSS 247 Issue 2, Section 5.2 (b)	*N/T
DTS Bandwidth	FCC 15.247(a)(2)	RSS 247 Issue 2, Section 5.2 (a)	*N/T
Emissions in non-restricted frequency bands	FCC 15.247(d)	RSS 247 Issue 2, Section 5.5	*N/T
Spurious Radiated Emissions and Restricted Bands of Operation	FCC 15.209 / FCC 15.205	RSS-Gen Issue 5, Section 8.9 /8.10	Pass
Conducted Emissions on a.c Power Lines	FCC 15.207	RSS-Gen Issue 5, Section 8.8	NA

Product Category: Electronics Testing
Test Discipline: EMC Test Facility

NA: Not Applicable

*N/T: Not tested – These test cases are not tested, the product uses certified RF module **QCNFA324** from **Qualcomm Atheros, Inc.**, with **FCC ID: PPD-QCNFA324 & IC ID: 4104A-QCNFA324.**

Prüfbericht - Nr.:
Test Report No.:

ULR-TC568820300000037F

Seite 3 von 45
Page 3 of 45

REVISION HISTORY OF THIS REPORT

Report Number	Version	Description	Issue date
ULR-TC568820300000037F	01	Initial issue of report	07.10.2020
ULR-TC568820300000037F	02	Reviewer comments updated	28.11.2020

Table of Contents

1	GENERAL REMARKS	5
1.1	Attachments	5
2	TEST SITES	6
2.1	Testing Facilities.....	6
2.2	List of Test and Measurement Instruments.....	6
3	GENERAL PRODUCT INFORMATION.....	8
3.1	Product Function and Intended Use.....	8
3.2	Ratings and System Details of Equipment under Test	8
3.3	Measurement Uncertainty:	9
4	TEST SET-UP AND OPERATION MODE	10
4.1	Principle of Configuration Selection	10
4.2	Test Operation and Test Software	10
4.3	Special Accessories and Auxiliary Equipment	10
4.4	Countermeasures to achieve EMC Compliance	10
4.5	Simultaneous Transmission	10
4.6	List of frequencies	11
4.7	Report references.....	12
5	Operational Description	13
6	Block Diagram.....	13
7	TEST METHODOLOGY	14
7.1	Radiated Emission Test	14
7.1.1	Test Setup Configuration	14
8	TEST RESULTS FOR Wi-Fi-2.4GHz.....	16
8.1	Spurious Radiated Emissions & Restricted Bands of Operation	16
9	TEST RESULTS FOR BLUETOOTH LOW ENERGY	37
9.1	Spurious Radiated Emissions & Restricted Bands of Operation	37
10	LIST OF TABLES.....	45
11	List of Figures.....	45

1 GENERAL REMARKS

1.1 Attachments

All attachments are part of this test report and are issued in separate document

1. TEST SETUP PHOTOS
2. EUT EXTERNAL PHOTOS
3. EUT INTERNAL PHOTOS
4. FCC LABEL AND LABEL LOCATION
5. BLOCK DIAGRAM
6. SPECIFICATION OF EUT
7. SCHEMATIC DIAGRAMS
8. BILL OF MATERIAL
9. USER MANUAL
10. Maximum Permissible Exposure Information

Prüfbericht - Nr.:
Test Report No.:

ULR-TC568820300000037F

Seite 6 von 45
Page 6 of 45

2 TEST SITES

2.1 Testing Facilities

1. TÜV Rheinland (India) Pvt.Ltd.,
27/B, 2nd Cross,
ElectronicCityPhase1
Bangalore – 560 100,
India
2. TUV Rheinland (India) Private Limited
108 , Beside ISBR Business School,
Electronic city Phase I
Bangalore - 560 100.
India

2.2 List of Test and Measurement Instruments

Table 1: List of test and measurement instruments

Equipment	Manufacturer	Model Name	Serial Number	Firmware Versions	Calibration Due Date	Periodicity	Test Facility
EMI Receiver	Rohde & Schwarz	ESU 40	100288	4.43 SP3	09.06.2021	Yearly	Radiated Spurious Emission
Active loop antenna	Schwarzbeck	FMZB 1519 B	1519B-00111	-	31.01.2021	Yearly	
Biconical Antenna	Schwarzbeck	VHBB91 24+BBA 9106	9124-1208+9106-0525	-	17.02.2021	Yearly	
Baloon and Biconical Antenna	Schwarzbeck mess-elektronik	VHBB-9124 / BBA-9106	01028	-	02.09.2021	Yearly	
Log - Periodical Antenna	Schwarzbeck	VULP 9118 A	VULP9118A-0733	-	13.02.2021	Yearly	
Horn Antenna	Schwarzbeck	BBHA 9170	BBHA 9170-0904	-	29.01.2021	Yearly	
Horn Antenna	Schwarzbeck	BBHA 9120 D	9120D-1944	-	30.01.2021	Yearly	
Semi Anechoic Chamber	Frankonia	-	-	-	-	-	
Fully Anechoic Chamber	Albatross	-	-	-	-	-	
EMI Receiver	Rohde & Schwarz	ESW 44	101732	-	10.12.2020	Yearly	

Prüfbericht - Nr.:
Test Report No.:

ULR-TC568820300000037F

Seite 7 von 45
Page 7 of 45

Table 2: Instrument application Software versions

SL. No.	Test Type	Application software	Version
1	Radiated spurious emission measurement in SAC	EMC 32	10.60.00
2	Radiated spurious emission measurement in FAC	EMC 32	10.60.00

3 GENERAL PRODUCT INFORMATION

3.1 Product Function and Intended Use

The 820 Nano SOM from Mistral is an easy to use, ultra-compact, light-weight System on Module providing very high processing power. The SOM is based on Qualcomm Snapdragon 820 and is ideal for advanced, next-gen embedded applications. With a PCB size of just 51mm x 26mm, this is one of the smallest Snapdragon based SOMs available in the market currently. Equipped with powerful specifications and features, the 820 Nano SOM is ideal for designs requiring 4K Ultra HD HEVC (H.265) video and graphics processing, wireless connectivity, low power consumption and advanced processing power. The feature-rich 820 Nano SOM supports latest features like Type-C functionality, 4K Encode/Decode and integrated 9-axis MEMS on a very small footprint, making it ideal for several powerful applications. The 820 Nano SOM is ideal for designing products like wearable computers, camera solutions, media gateways, Infotainment, drones, assistive devices and other smart gadgets requiring small package and high processing power.

3.2 Ratings and System Details of Equipment under Test

Table 3: Ratings and System Details as declared by Client*

Radio Protocol	Wi-Fi 2.4GHz	BLE
Operating Frequency Range	2412MHz to 2462MHz	2402MHz to 2480MHz
No. of Channels	11 (Refer Table 5)	40 (Refer Table 6)
Channel Spacing	5MHz	2MHz
Maximum Measured Power (e.i.r.p)	21.75 dBm (1Mbps 2437MHz)	4.55 dBm(1Mbps 2480MHz)
Modulation	802.11b: CCK, DQPSK, DBPSK 802.11a/g: 64QAM,16QAM, QPSK, BPSK 802.11n: 64QAM,16QAM, QPSK, BPSK VHT20 & VHT40	GFSK
Number of antennas	2	1
Antenna Gain	Peak gain (2.0dBi) Average gain(-0.5dBi)	
Antenna Type & Part No	SMD Type, SR42W001	
Supply Voltage to Product	4.2 V DC Supply	
Environmental conditions	0°C to +70°C Relative Humidity <95%	
EUT Dimension	51 x 26 x 1.63 mm (LxWxH)	

***Disclaimer:** The information/data is supplied by the client and the same is considered to arrive at the final value. Any changes made apart from the specified specification, can directly impact on the tests results. Refer the products user manual for more details.

Note: Product SD820 Nano SOM- Wi-Fi Module has multiple protocols. All the supported wireless protocols and their respective test results are issued in separate test reports, refer clause 4.7 Report references

3.3 Measurement Uncertainty:

Reported uncertainties represent expanded uncertainties expressed at approximately the 95% confidence level using a coverage factor of $k = 2$

Table 4: Measurement Uncertainty

Parameter	Uncertainty
Occupied Channel Bandwidth	±5 %
RF output power, conducted	±1.5 dB
Power Spectral Density, conducted	±3 dB
Unwanted Emissions, conducted	±3 dB
All emissions, radiated	±6 dB
Temperature	±3 °C
Supply Voltages	±3 %
Time	±5 %

Note: The Listed Measurement Uncertainties are the worst-case uncertainty, for the respective test cases. Above Table is for reporting purpose only and not used in determining Final Pass/Fail verdict.

4 TEST SET-UP AND OPERATION MODE

4.1 Principle of Configuration Selection

Transmission was enabled with highest possible duty cycle transmission on low, mid and high channel.

4.2 Test Operation and Test Software

Hardware Version:	RevB
Hardware Version Identification Number(s) (HVIN):	QCNFA324
Software Version:	Andr_oreo_8.0
Firmware Version Identification Number(s) (FVIN):	eeeprom_ar6320_3p0_NFA324i_5.bin

4.3 Special Accessories and Auxiliary Equipment

- Test laptop and USB cable

4.4 Countermeasures to achieve EMC Compliance

- None

4.5 Simultaneous Transmission

- Device support simultaneous transmission, measured levels under simultaneous Transmission are same as the stand- alone transmission hence not reported

4.6 List of frequencies

Frequency Band (MHz)	Channel No.	Channel Frequency (MHz)
2412 – 2462	1	2412
	2	2417
	3	2422
	4	2427
	5	2432
	6	2437
	7	2442
	8	2447
	9	2452
	10	2457
	11	2462

Table 5: List of Wi-Fi center Frequencies

Channel used for Wi-Fi testing

Channel Bandwidth 20MHz

Channel low : 2412MHz

Channel mid : 2437MHz

Channel high : 2462MHz

Channel Bandwidth 40MHz

Channel low : 2422MHz

Channel mid : 2437MHz

Channel high : 2452MHz

Frequency Band (GHz)	Channel No.	Frequency (MHz)
BLE (2.4-2.4835)	0	2402
	1	2404
	2	2406
	3	2408
	:	:
	:	:
	18	2438
	19	2440
	20	2437
	:	:
	:	:
	36	2474
	37	2476
	38	2478
	39	2480

Table 6: List of BLE Center frequencies

Channel used for BLE testing

Channel low : 2402MHz

Channel mid : 2440MHz

Channel High : 2480MHz

Prüfbericht - Nr.:
Test Report No.:

ULR-TC568820300000037F

Seite 12 von 45
Page 12 of 45

Note:

TUV Sample Identification number : A001073243-002 -Radiated & SAR test Sample
A001073243-001 – Conducted test Sample

4.7 Report references

Note: Product SD820 Nano SOM- Wifi Module has multiple protocols. All the supported wireless protocols and their respective test results are issued in separate test reports, following table lists the report numbers.

Radio Protocol	Report Number
RF test report for Wi-Fi (2.4GHz) & BLE (2.4GHz) – (This report)	ULR-TC568820300000037F
RF test report for BT (2.4GHz)	ULR-TC568820300000038F
RF test report for Wi-Fi (5GHz)	ULR-TC568820300000039F
SAR test report for Wi-Fi(2.4 & 5GHz) & BT (2.4GHz)	ULR-TC568820300000040F

5 Operational Description

Based on a complete "System on Module" architecture, the 820 Nano SOM consists of ®™ the 64-bit quad-core Qualcomm Kryo CPU, 2.2GHz capable of 4K Encode/Decode, 3/4GB LPDDR4, 32/64GB UFS and with major interfaces available via inter-board connectors. Application Development on the 820 Nano SOM is enabled with Android and Embedded Linux through a feature-rich carrier board that enables prototyping in record time. Optional Adaptor boards like LCD, Camera, Sensors and Battery Charger are also available for increased scope of development around the 820 Nano SOM.

6 Block Diagram

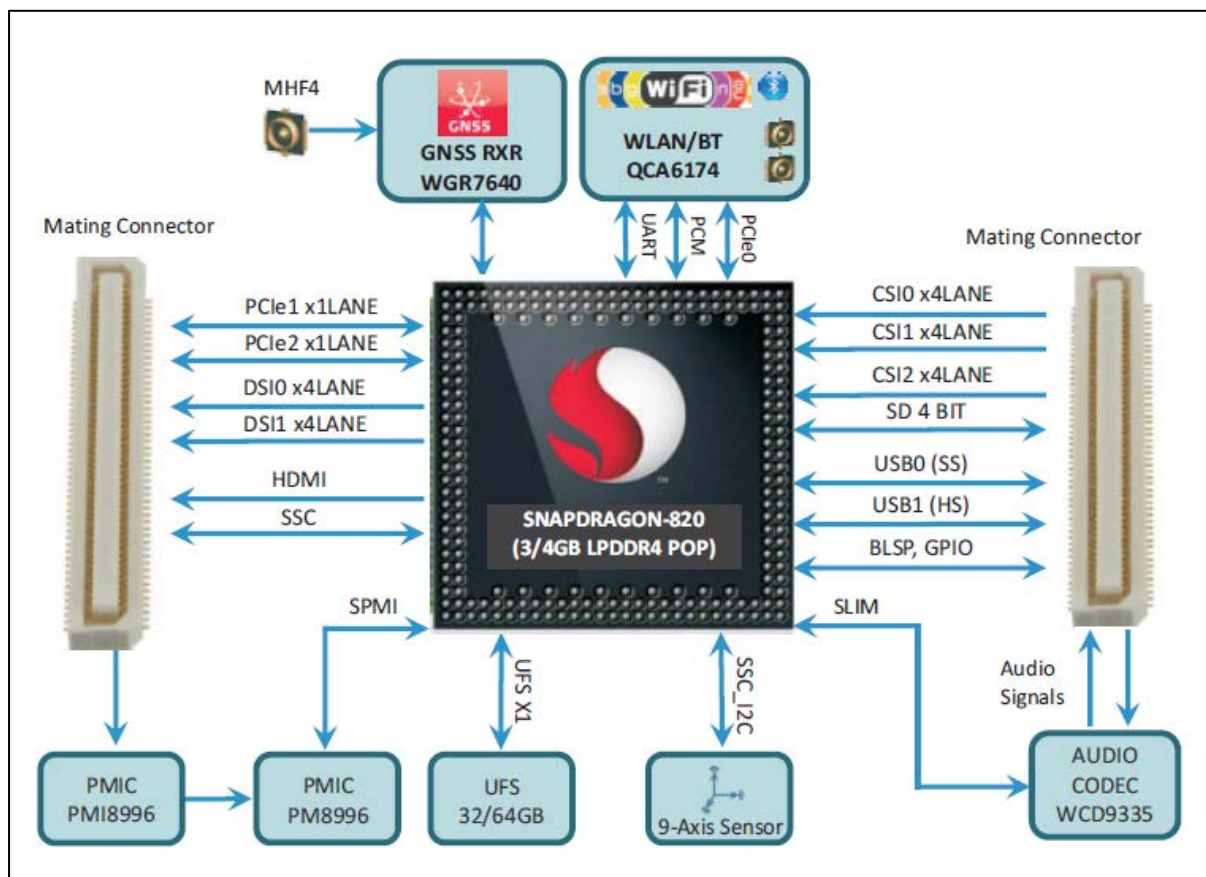

7 TEST METHODOLOGY

7.1 Radiated Emission Test

The radiated emission measurement was performed according to the procedures in ANSI C63.10-2013. The equipment under test (EUT) was placed at the middle of the 80 cm high turntable for below 1 GHz & 1.5 m height for above 1 GHz measurement, and the EUT is 3 meters far from the measuring antenna. The turntable was rotated 360° for obtaining the maximum emission. The height of the measuring antennas was scanned between 1 m and 4 m, and the antenna rotated to repeat the measurements for both the horizontal and vertical antenna polarizations. Repeat the measurement steps until the maximum emissions were obtained. The measurement above 1000 MHz was performed by horn antenna, The measurement below 30 MHz was performed by loop antenna, Measurement from 30 MHz to 200 MHz was performed by Baloon and Biconical Antenna, and mesurement from 200 MHz to 1 GHz was performed by Log-Periodic Antenna.

The EUT was rotated around the X-, Y-, and Z-Axis and the results from worst case axis are recorded

7.1.1 Test Setup Configuration

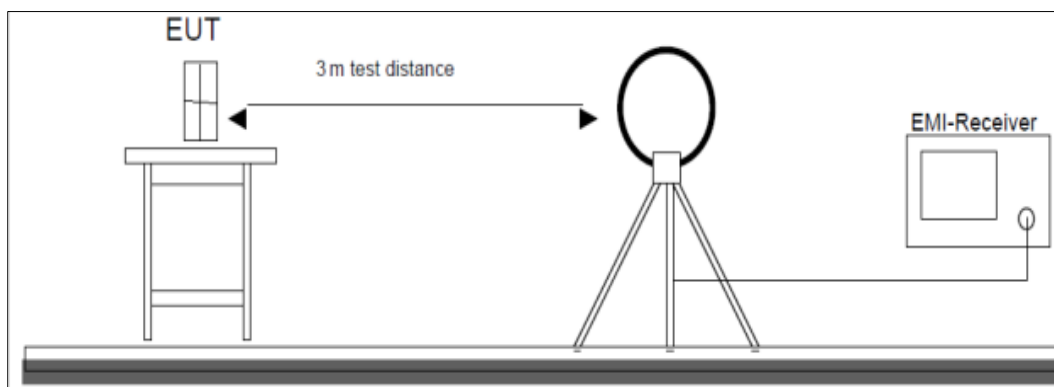

Figure 1: Frequency Range 9 kHz- 30 MHz

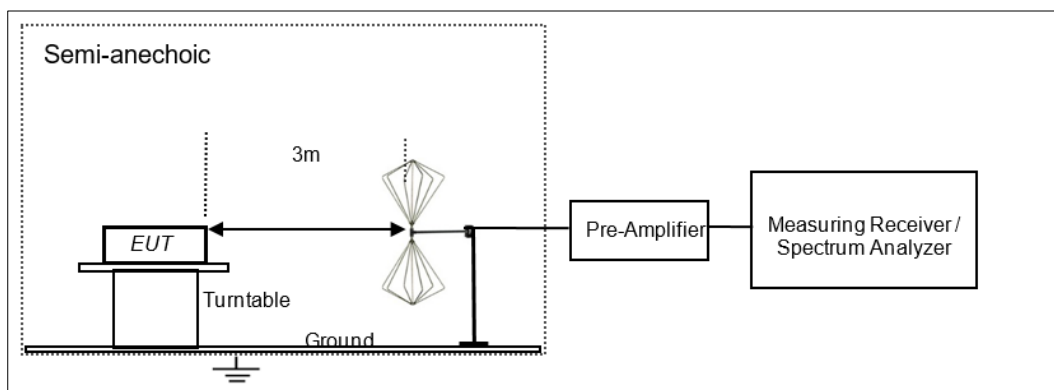

Figure 2: Frequency Range 30 MHz – 200 MHz

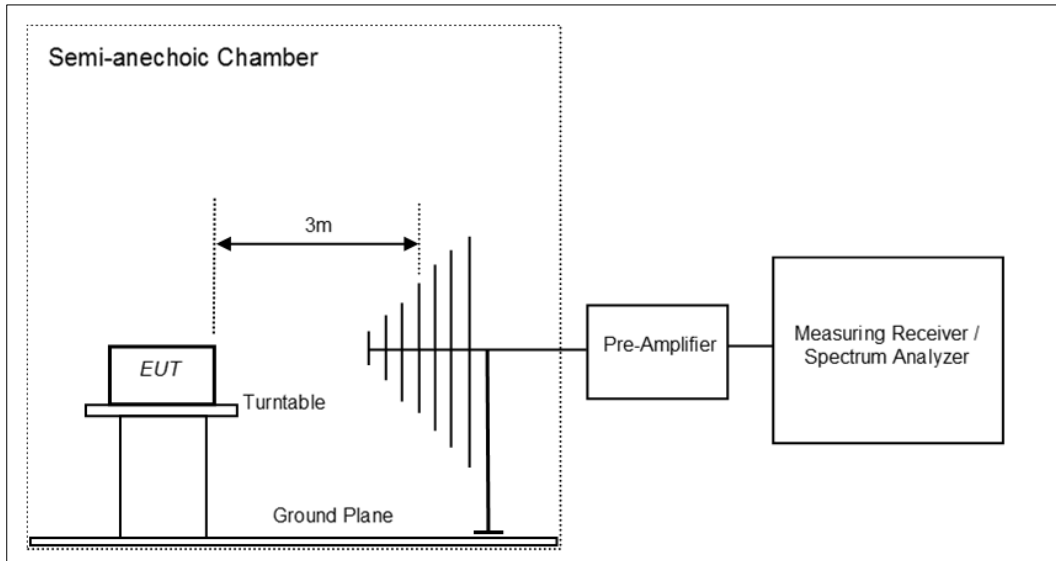

Figure 3: Frequency Range 200 MHz - 1GHz

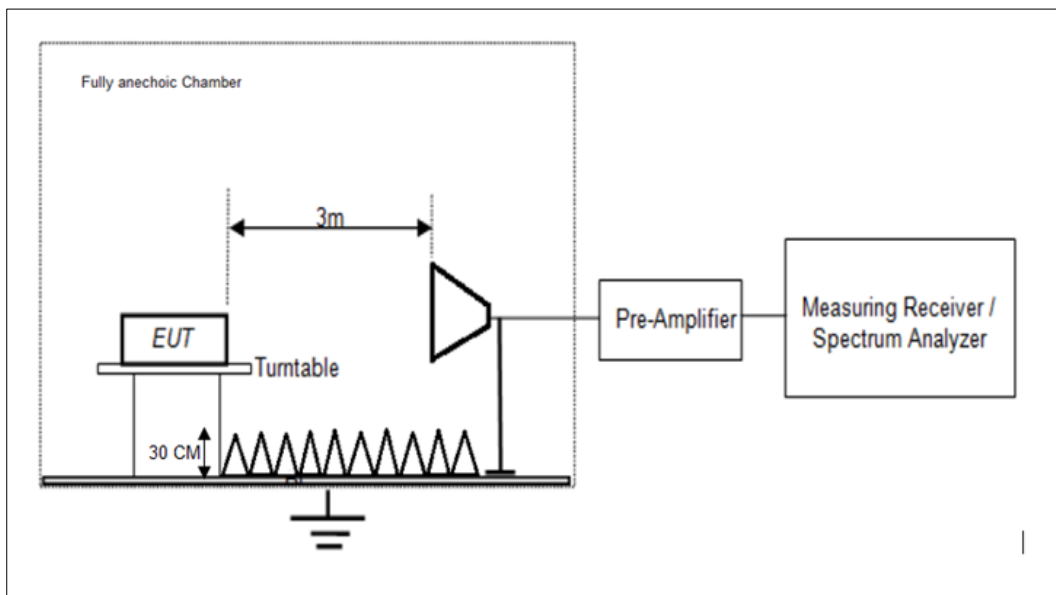

Figure 4: Frequency Range above 1 GHz

8 TEST RESULTS FOR Wi-Fi-2.4GHz

8.1 Spurious Radiated Emissions & Restricted Bands of Operation

Result	Pass
Test Specification	FCC part 15 Subpart C 15.247 (d) / (15.209 & 15.205) / IC RSS-GEN, Section 8.9 and 8.10
Test Method	ANSI C63.10
Measurement Location	Semi Anechoic Chamber 30MHz - 1 GHz Fully Anechoic Chamber 1 GHz - 40GHz
Measurement Bandwidth	100 kHz for frequency range < 1GHz 1 MHz for Frequency range >1GHz
Detector	Refer remarks below
Measuring Distance	3 m
Requirement	As per the limits mentioned in the below table
Test setup	Reffer TEST METHODOLOGY

Table 7: Transmitter limits for Radiated emission

Frequency (MHz)	Field strength (μV/m)	Field strength (dBμV/m)	Distance of Measurement (m)
0.009 – 0.490	2400/F(kHz)	48.50 – 13.80	300*
0.490 – 1.705	24000/F(kHz)	33.80 – 23.00	30*
1.705 -30	30	29.54	30*
30-88	100	40.0	3
88-216	150	43.5	3
216-960	200	46.0	3
Above 960	500	54.0	3

Remark: * The limit shows in the table above of frequency range 0.009 – 0.490, 0.490 – 1.705 MHz and 1.705-30MHz is at 300 meter, 30 meter and 30 meter range respectively, which corresponds to 128.51 – 93.80, 73.80 – 62.96 and 69.54 dBμV/m at 3m range by extrapolation calculation and the measurement of loop antenna.

The emission limits shown in the above table are based on measurements employing a CISPR quasi-peak detector except for the frequency bands 9–90 kHz, 110–490 kHz and above 1000 MHz Radiated emission limits in these three bands are based on measurements employing an average detector.

Test Conditions:

Temperature (Norm) = + 23.5 °C

Voltage = 4.2VDC input

Relative humidity = 62 %

Test results:

Note: All the losses are included during measurement and final values are mentioned in the test report. Refer TEST METHODOLOGY. for more details

Test results for frequency range 9kHz – 30MHz

No emissions found in frequency range 9 kHz to 30 MHz, and measured levels are below 20dB from the limit line, hence not reported

Test results for frequency range 30MHz – 200MHz

Antenna Polarization	Frequency (MHz)	Peak (dBµV/m)	Limit (dBµV/m)	Margin (dB)
Vertical	35.28	17.39	40.00	-22.61
	44.57	18.51	40.00	-21.49
	93.38	20.02	43.50	-23.48
	184.94	25.75	43.50	-17.75
Horizontal	32.12	11.24	40.00	-28.76
	37.65	10.93	40.00	-29.07
	92.53	22.08	43.50	-21.42
	186.88	28.54	43.50	-14.96

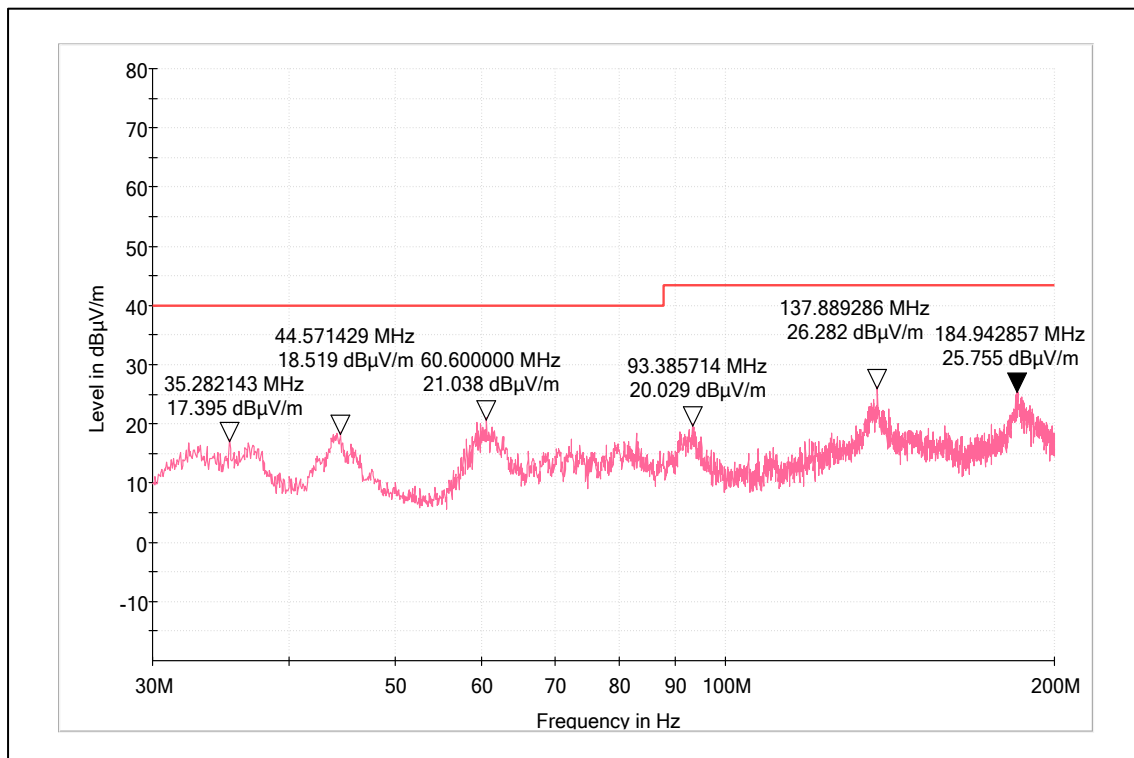

Channel Frequency 30MHz – 200MHz

Polarization Vertical

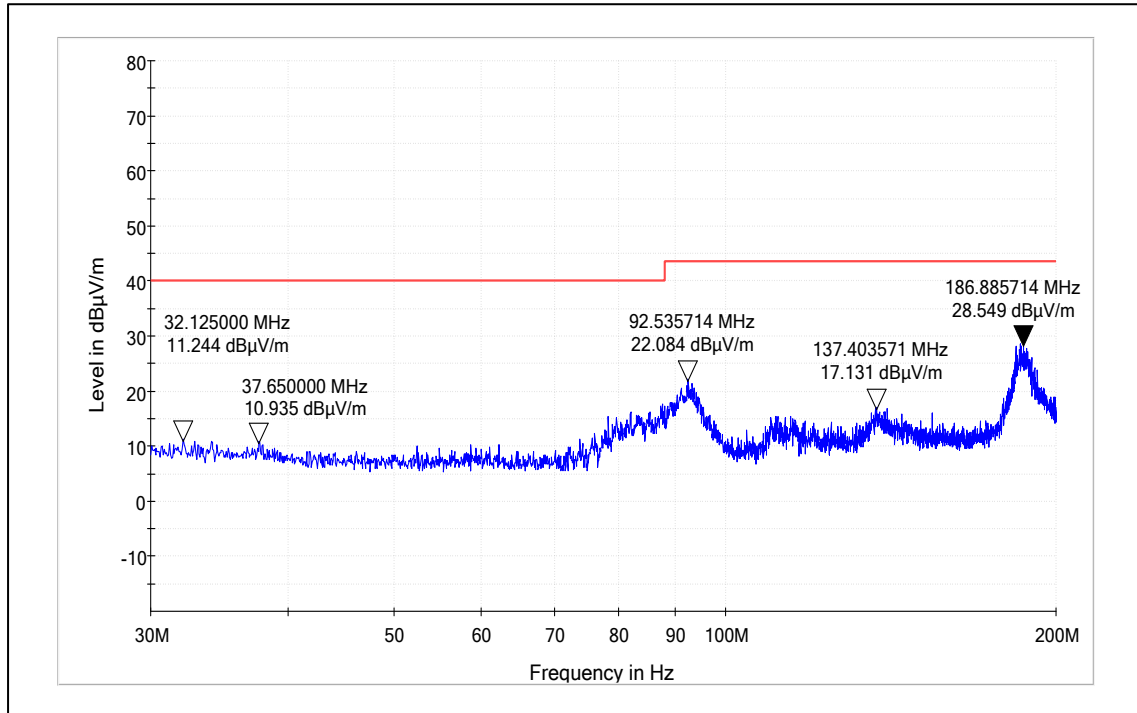

Channel Frequency 30MHz – 200MHz

Polarization Horizontal

Test results for frequency range 200MHz – 1GHz

Antenna Polarization	Frequency (MHz)	Peak (dBµV/m)	Limit (dBµV/m)	Margin (dB)
Vertical	235.80	32.53	46.00	-13.47
	272.63	28.69	46.00	-17.31
	567.12	22.05	46.00	-23.95
	839.76	31.73	46.00	-14.27
Horizontal	233.29	26.81	46.00	-19.19
	384.01	25.70	46.00	-20.30
	623.67	23.50	46.00	-22.50
	832.50	25.73	46.00	-20.27

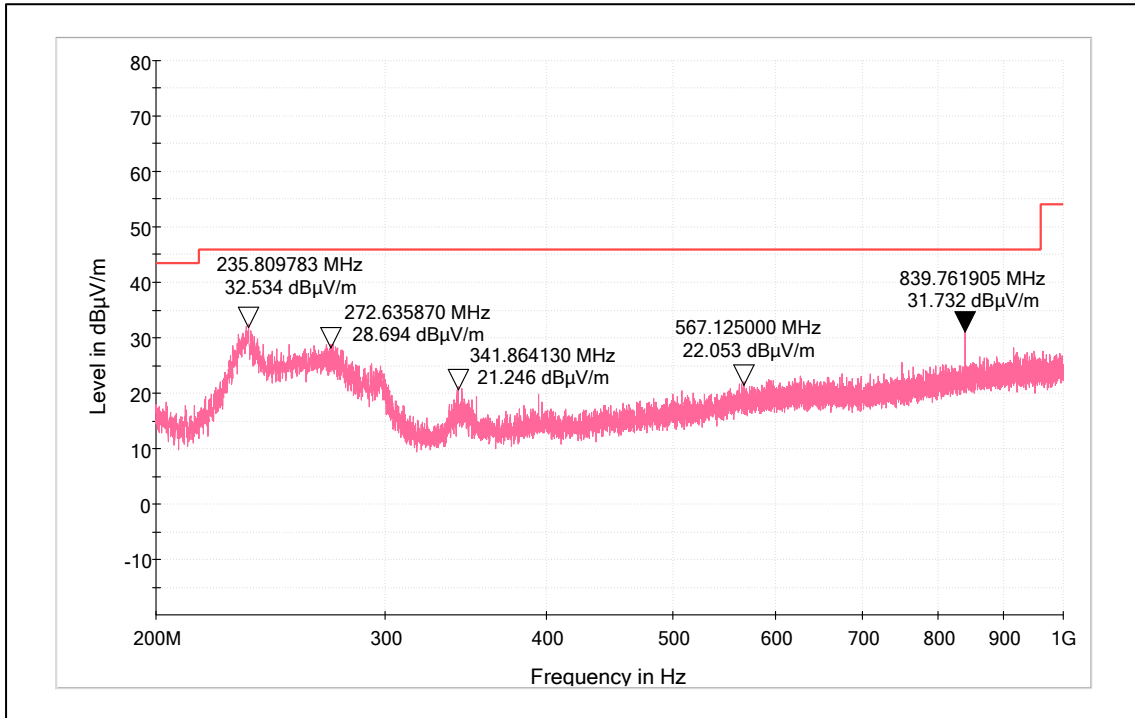

Channel Frequency 200MHz – 1GHz

Polarization Vertical

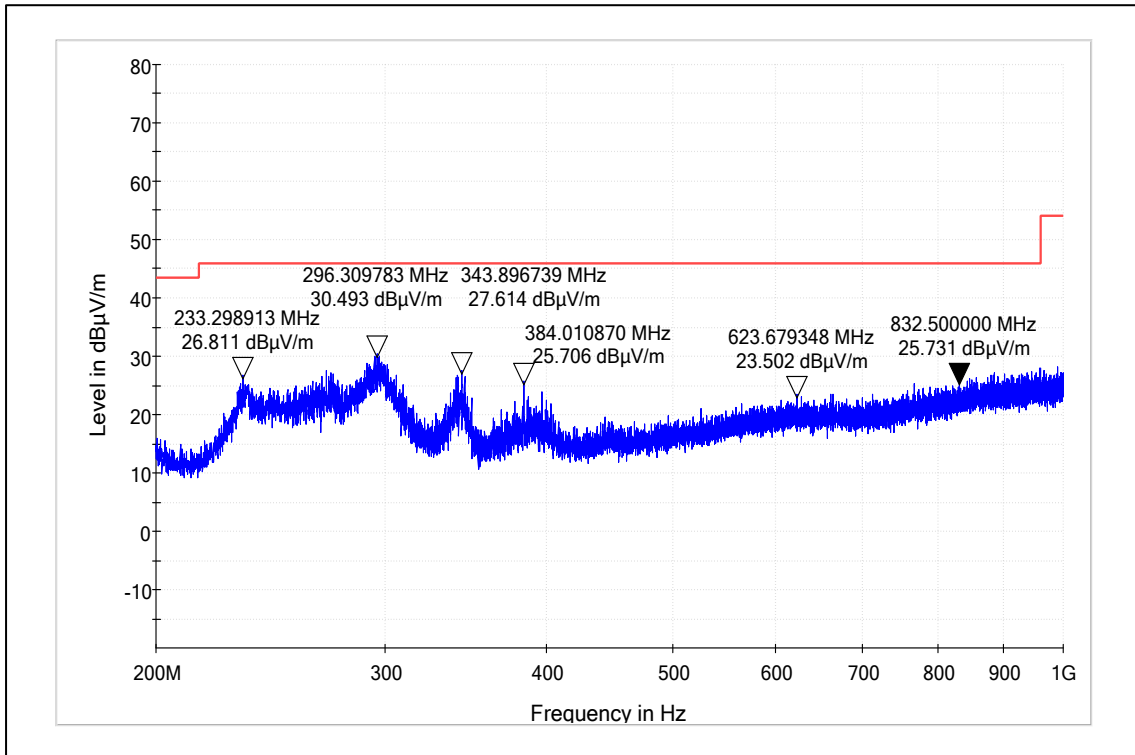

Channel Frequency 200MHz – 1GHz

Polarization Horizontal

Prüfbericht - Nr.:
Test Report No.:

ULR-TC568820300000037F

Seite 20 von 45
Page 20 of 45

Test results for the frequencies in the range 1 GHz to 26.5 GHz

Modulation: 802.11b

Data Rate: 1Mbps

Channel Frequency (MHz)	Antenna Polarization	Measured Frequency (MHz)	Field Strength (dBµV/m)	Limit (dBµV/m)	Margin (dB)
2412	Vertical	2390(Pk)	48.89	74*	-25.11
		2390(Av)	37.40	54*	-16.6
		2412(Pk)	100.93	-	-
		2412(Av)	98.09	-	-
		4824(Pk)	51.98	74	-22.02
		4824(Av)	48.61	54	-5.39
		7236(Pk)	No Harmonics Found		
	7236(Av)	No Harmonics Found			
	Horizontal	2390(Pk)	53.09	74*	-20.91
		2390(Av)	41.76	54*	-12.24
		2412(Pk)	105.44	-	-
		2412(Av)	103.03	-	-
		4824(Pk)	47.80	74	-26.2
		4824(Av)	43.17	54	-10.83
7236(Pk)		No Harmonics Found			
7236(Av)	No Harmonics Found				
2437	Vertical	2437(Pk)	100.07	-	-
		2437(Av)	97.63	-	-
		4874(Pk)	48.28	74	-25.72
		4874(Av)	44.17	54	-9.83
		7311(Pk)	No Harmonics Found		
	7311(Av)	No Harmonics Found			
	Horizontal	2437(Pk)	102.09	-	-
		2437(Av)	99.62	-	-
		4874(Pk)	46.57	74	-27.43
		4874(Av)	40.33	54	-13.67
7311(Pk)		No Harmonics Found			
7311(Av)	No Harmonics Found				
2462	Vertical	2462(Pk)	100.10	-	-
		2462(Av)	97.73	-	-
		2483.5(Pk)	46.96	74*	-27.04
		2483.5(Av)	34.85	54*	-19.15
		4924(Pk)	49.60	74	-24.4
		4924(Av)	45.28	54	-8.72
		7386(Pk)	No Harmonics Found		
	7386(Av)	No Harmonics Found			
	Horizontal	2462(Pk)	102.36	-	-
		2462(Av)	99.89	-	-
		2483.5(Pk)	50.83	74*	-23.17
		2483.5(Av)	38.09	54*	-15.91
		4924(Pk)	47.46	74	-26.54
		4924(Av)	41.08	54	-12.92
7386(Pk)		No Harmonics Found			
7386(Av)	No Harmonics Found				

* : Indicate restricted band of operation §15.205
Pk: Peak Detector; Av: Average Detector

Prüfbericht - Nr.:
Test Report No.:

ULR-TC568820300000037F

Seite 21 von 45
Page 21 of 45

Modulation: 802.11g
Data Rate: 6Mbps

Channel Frequency (MHz)	Antenna Polarization	Measured Frequency (MHz)	Field Strength (dBµV/m)	Limit (dBµV/m)	Margin (dB)
2412	Vertical	2390(Pk)	58.4	74*	-15.6
		2390(Av)	44.46	54*	-9.54
		2412(Pk)	103.24	-	-
		2412(Av)	92.44	-	-
		4824(Pk)	56.86	74	-17.14
		4824(Av)	43.67	54	-10.33
		7236(Pk)	No Harmonics Found		
	7236(Av)	No Harmonics Found			
	Horizontal	2390(Pk)	62.07	74*	-11.93
		2390(Av)	46.15	54*	-7.85
		2412(Pk)	104.97	-	-
		2412(Av)	95	-	-
		4824(Pk)	52.83	74	-21.17
		4824(Av)	39.49	54	-14.51
7236(Pk)		No Harmonics Found			
7236(Av)	No Harmonics Found				
2437	Vertical	2437(Pk)	102.44	-	-
		2437(Av)	92.43	-	-
		4874(Pk)	58.91	74	-15.09
		4874(Av)	46.23	54	-7.77
		7311(Pk)	No Harmonics Found		
	7311(Av)	No Harmonics Found			
	Horizontal	2437(Pk)	104.89	-	-
		2437(Av)	94.6	-	-
		4874(Pk)	54.29	74	-19.71
		4874(Av)	40.54	54	-13.46
7311(Pk)		No Harmonics Found			
7311(Av)	No Harmonics Found				
2462	Vertical	2462(Pk)	101.72	-	-
		2462(Av)	92.1	-	-
		2483.5(Pk)	51.72	74*	-22.28
		2483.5(Av)	39.47	54*	-14.53
		4924(Pk)	60.3	74	-13.7
		4924(Av)	47.36	54	-6.64
		7386(Pk)	No Harmonics Found		
	7386(Av)	No Harmonics Found			
	Horizontal	2462(Pk)	104.51	-	-
		2462(Av)	94.67	-	-
		2483.5(Pk)	54.66	74*	-19.34
		2483.5(Av)	42.01	54*	-11.99
		4924(Pk)	54.01	74	-19.99
		4924(Av)	40.18	54	-13.82
7386(Pk)		No Harmonics Found			
7386(Av)	No Harmonics Found				

* : Indicate restricted band of operation §15.205
Pk: Peak Detector; Av: Average Detector

Prüfbericht - Nr.:
Test Report No.:

ULR-TC568820300000037F

Seite 22 von 45
Page 22 of 45

Modulation: VHT20
Data Rate: MCS0

Channel Frequency (MHz)	Antenna Polarization	Measured Frequency (MHz)	Field Strength (dBµV/m)	Limit (dBµV/m)	Margin (dB)	
2412	Vertical	2390(Pk)	59.96	74*	-14.04	
		2390(Av)	45.31	54*	-8.69	
		2412(Pk)	102.96	-	-	
		2412(Av)	92.93	-	-	
		4824(Pk)	56.16	74	-17.84	
		4824(Av)	43.75	54	-10.25	
		7236(Pk)	No Harmonics Found			
		7236(Av)	No Harmonics Found			
	Horizontal	2390(Pk)	62.12	74*	-11.88	
		2390(Av)	48.3	54*	-5.7	
		2412(Pk)	104.53	-	-	
		2412(Av)	95.55	-	-	
		4824(Pk)	51.11	74	-22.89	
		4824(Av)	37.61	54	-16.39	
		7236(Pk)	No Harmonics Found			
		7236(Av)	No Harmonics Found			
2437	Vertical	2437(Pk)	102.95	-	-	
		2437(Av)	92.5	-	-	
		4874(Pk)	59.17	74	-14.83	
		4874(Av)	45.79	54	-8.21	
		7311(Pk)	No Harmonics Found			
	7311(Av)	No Harmonics Found				
	Horizontal	2437(Pk)	104.63	-	-	
		2437(Av)	95.12	-	-	
		4874(Pk)	53.46	74	-20.54	
		4874(Av)	39.39	54	-14.61	
7311(Pk)		No Harmonics Found				
7311(Av)	No Harmonics Found					
2462	Vertical	2462(Pk)	102.76	-	-	
		2462(Av)	92.55	-	-	
		2483.5(Pk)	53.77	74*	-20.23	
		2483.5(Av)	39.61	54*	-14.39	
		4924(Pk)	60.52	74	-13.48	
		4924(Av)	47.22	54	-6.78	
		7386(Pk)	No Harmonics Found			
		7386(Av)	No Harmonics Found			
	Horizontal	2462(Pk)	103.89	-	-	
		2462(Av)	94.52	-	-	
		2483.5(Pk)	57.19	74*	-16.81	
		2483.5(Av)	43.24	54*	-10.76	
		4924(Pk)	54.67	74	-19.33	
		4924(Av)	40.56	54	-13.44	
7386(Pk)	No Harmonics Found					
7386(Av)	No Harmonics Found					

* : Indicate restricted band of operation §15.205
Pk: Peak Detector; Av: Average Detector

Prüfbericht - Nr.:
Test Report No.:

ULR-TC568820300000037F

Seite 23 von 45
Page 23 of 45

Modulation: VHT40
Data Rate: MCS0

Channel Frequency (MHz)	Antenna Polarization	Measured Frequency (MHz)	Field Strength (dBµV/m)	Limit (dBµV/m)	Margin (dB)
2422	Vertical	2390(Pk)	64.73	74*	-9.27
		2390(Av)	48.43	54*	-5.57
		2422(Pk)	98.49	-	-
		2422(Av)	88.03	-	-
		4844(Pk)	57.22	74	-16.78
		4844(Av)	43.45	54	-10.55
		7266(Pk)	No Harmonics Found		
	7266(Av)	No Harmonics Found			
	Horizontal	2390(Pk)	65.84	74*	-8.16
		2390(Av)	51.51	54*	-2.49
		2422(Pk)	100.93	-	-
		2422(Av)	90.63	-	-
		4844(Pk)	52.49	74	-21.51
		4844(Av)	38.62	54	-15.38
7266(Pk)		No Harmonics Found			
7266(Av)	No Harmonics Found				
2437	Vertical	2437(Pk)	97.54	-	-
		2437(Av)	86.95	-	-
		4874(Pk)	58.37	74	-15.63
		4874(Av)	44.86	54	-9.14
		7311(Pk)	No Harmonics Found		
	7311(Av)	No Harmonics Found			
	Horizontal	2437(Pk)	99.31	-	99.31
		2437(Av)	89.55	-	89.55
		4874(Pk)	53.31	74	-20.69
		4874(Av)	39.93	54	-14.07
7311(Pk)		No Harmonics Found			
7311(Av)	No Harmonics Found				
2452	Vertical	2452(Pk)	97.64	-	-
		2452(Av)	87.33	-	-
		2483.5(Pk)	59.80	74*	-14.20
		2483.5(Av)	39.57	54*	-14.43
		4904(Pk)	59.89	74	-14.11
		4904(Av)	45.93	54	-8.07
		7356(Pk)	No Harmonics Found		
	7356(Av)	No Harmonics Found			
	Horizontal	2452(Pk)	100.78	-	-
		2452(Av)	90.08	-	-
		2483.5(Pk)	63.13	74*	-10.87
		2483.5(Av)	44.07	54*	-9.93
		4904(Pk)	54.69	74	-19.31
		4904(Av)	41.02	54	-12.98
7356(Pk)		No Harmonics Found			
7356(Av)	No Harmonics Found				

* : Indicate restricted band of operation §15.205
Pk: Peak Detector; Av: Average Detector

Worst case Plots

Data Rate: 1Mbps

Channel Frequency 2412MHz

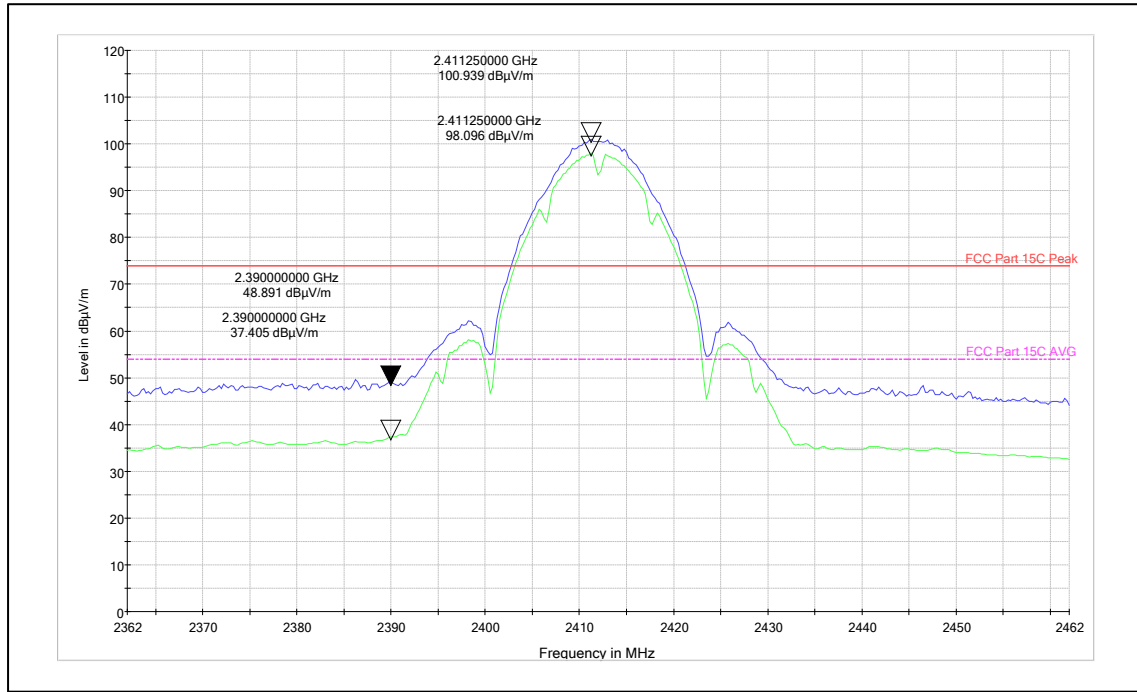

Channel Frequency: 2412MHz

Polarization: Vertical

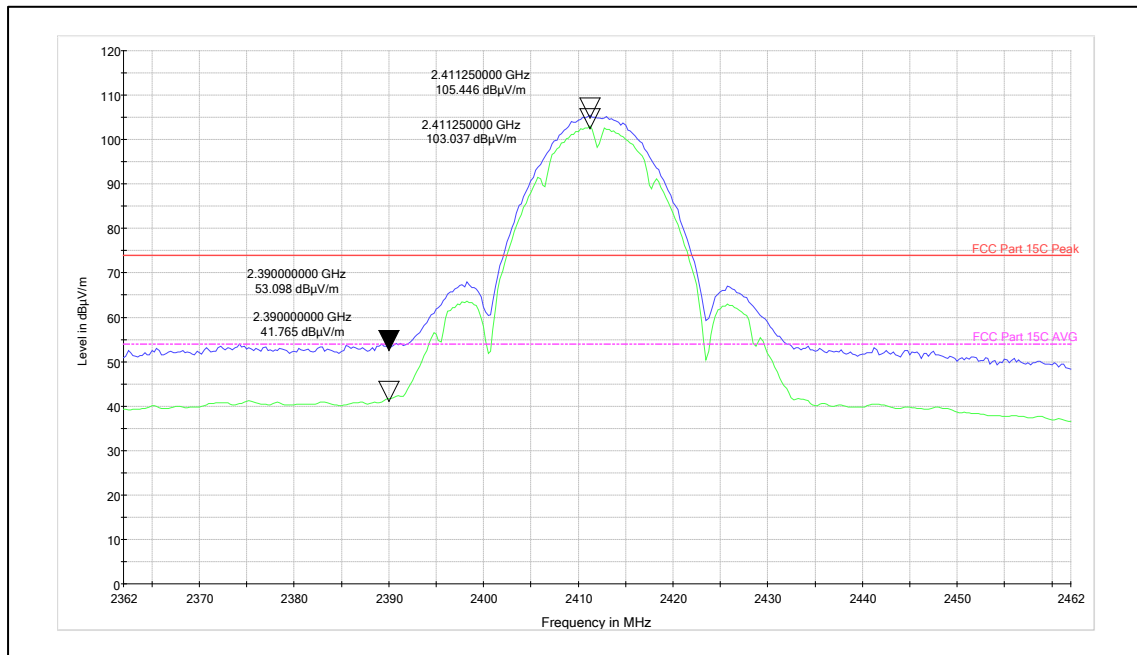

Channel Frequency: 2412MHz

Polarization: Horizontal

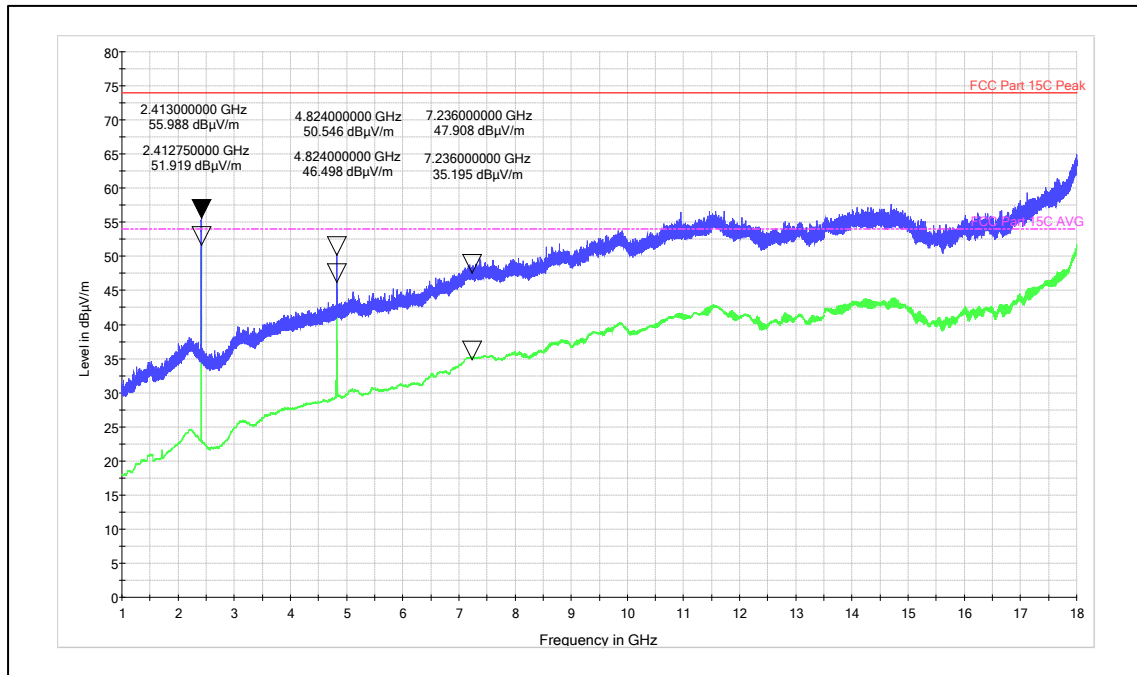

Channel Frequency: 1 - 18 GHz

Polarization: Vertical

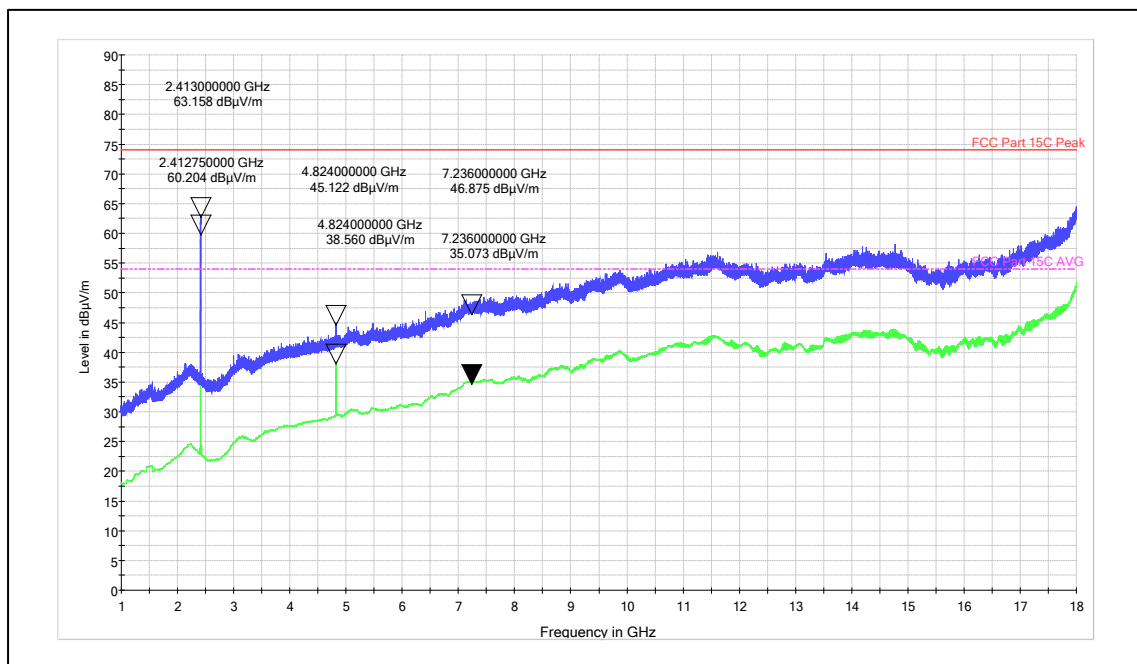

Channel Frequency: 1 - 18 GHz

Polarization: Horizontal

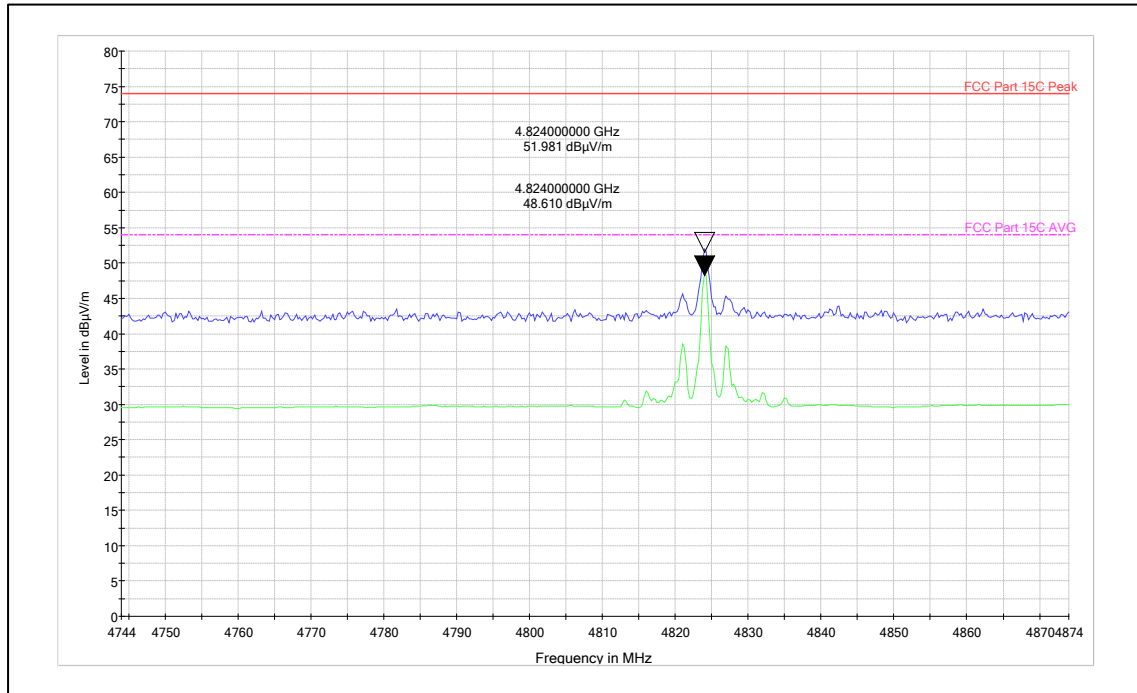

Channel Frequency: 2nd Harmonics

Polarization: Vertical

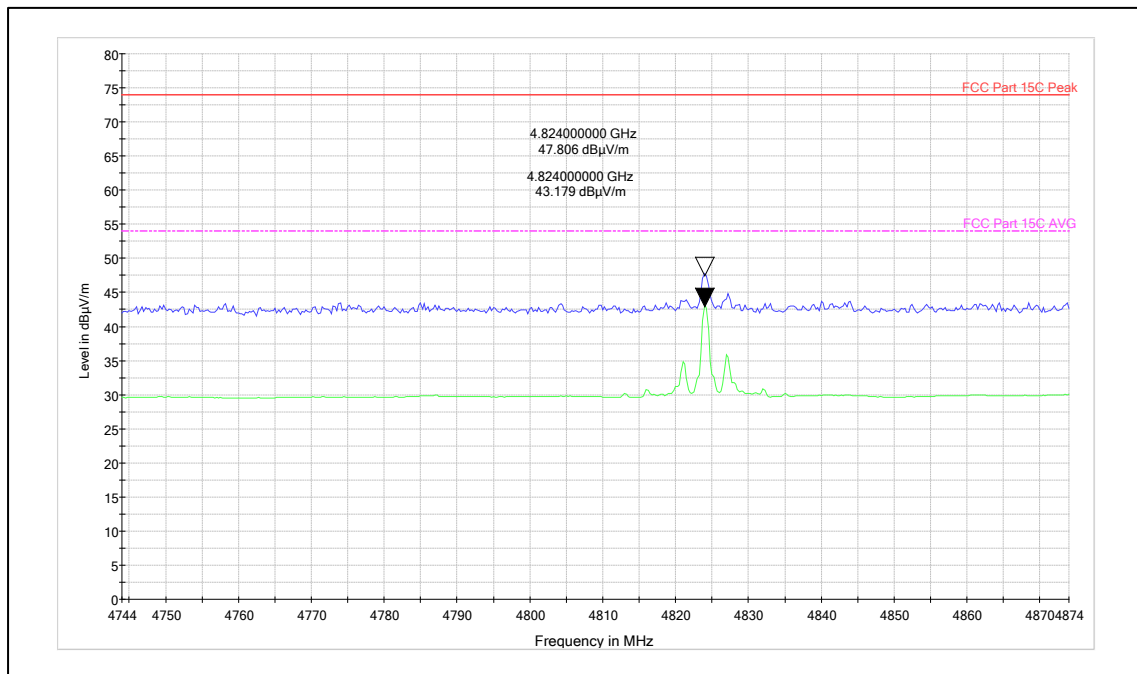

Channel Frequency: 2nd Harmonics

Polarization: Horizontal

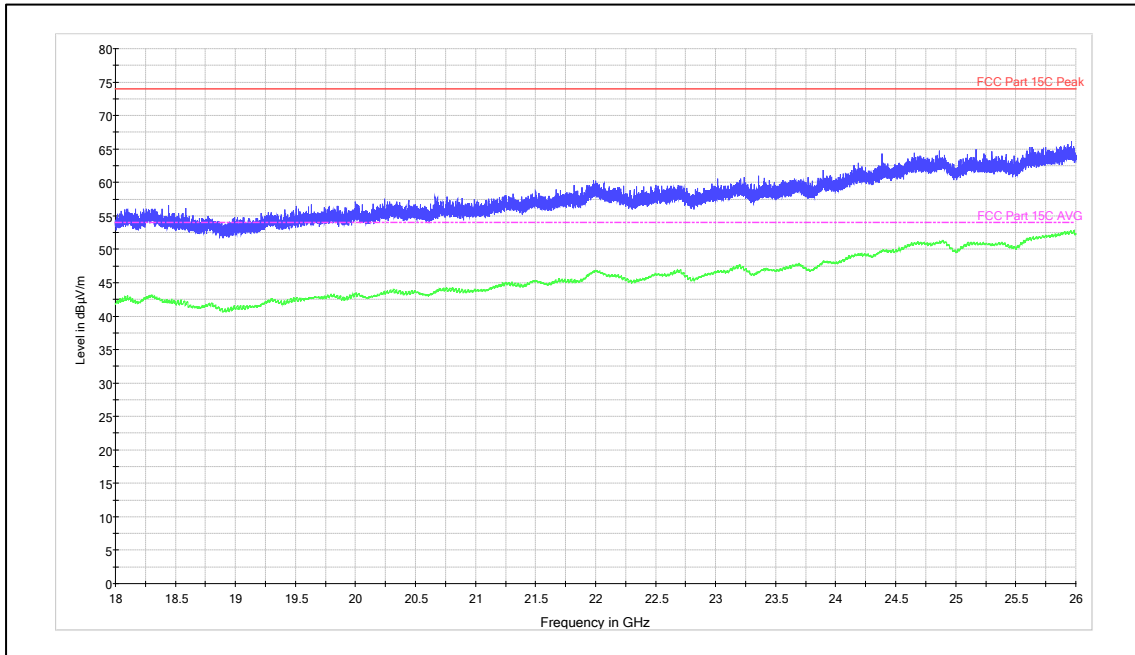

Channel Frequency: 18 - 26 GHz

Polarization: Vertical

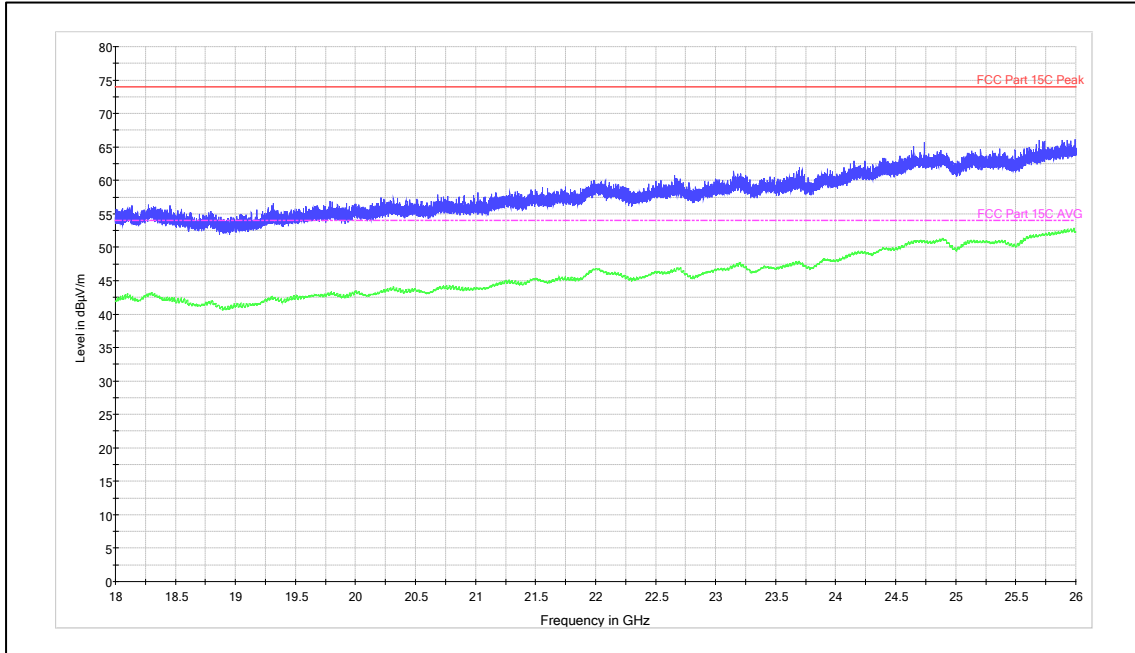

Channel Frequency: 18 - 26 GHz

Polarization: Horizontal

Data Rate: 6Mbps

Channel Frequency 2412MHz

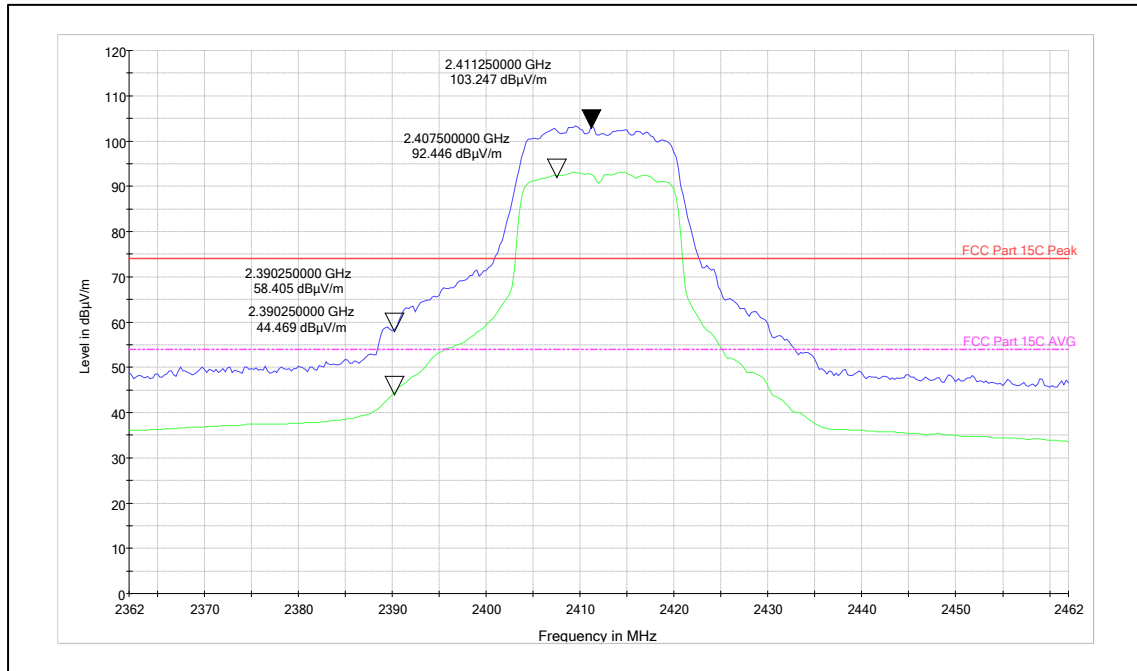

Channel Frequency: 2412MHz

Polarization: Vertical

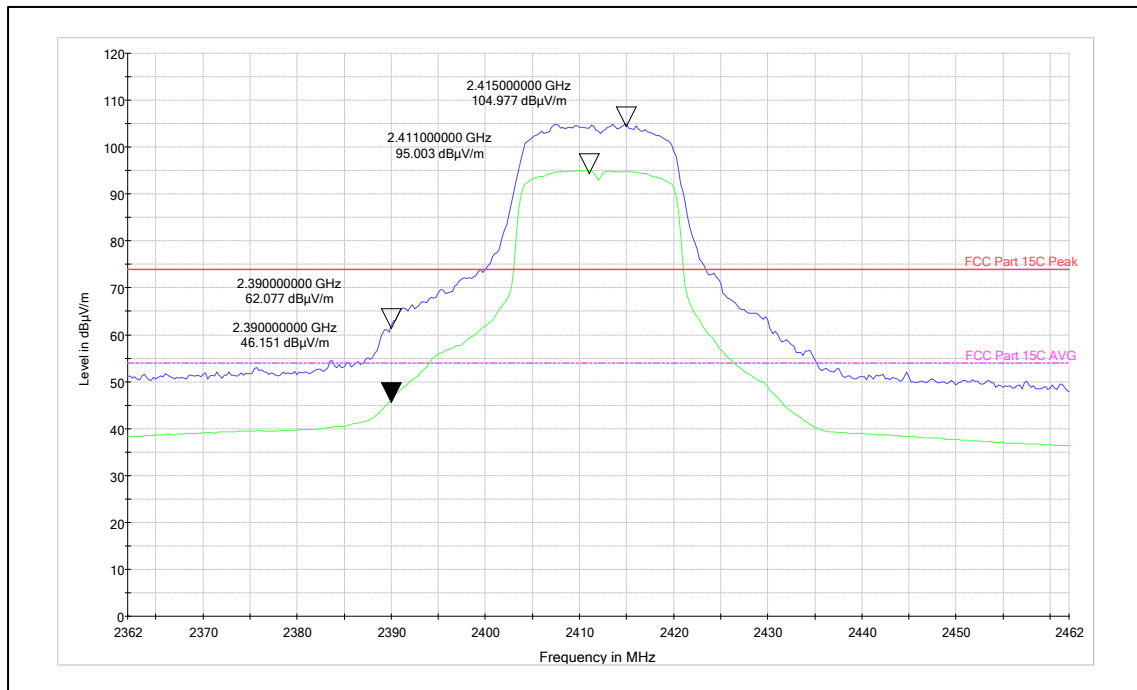

Channel Frequency: 2412MHz

Polarization: Horizontal

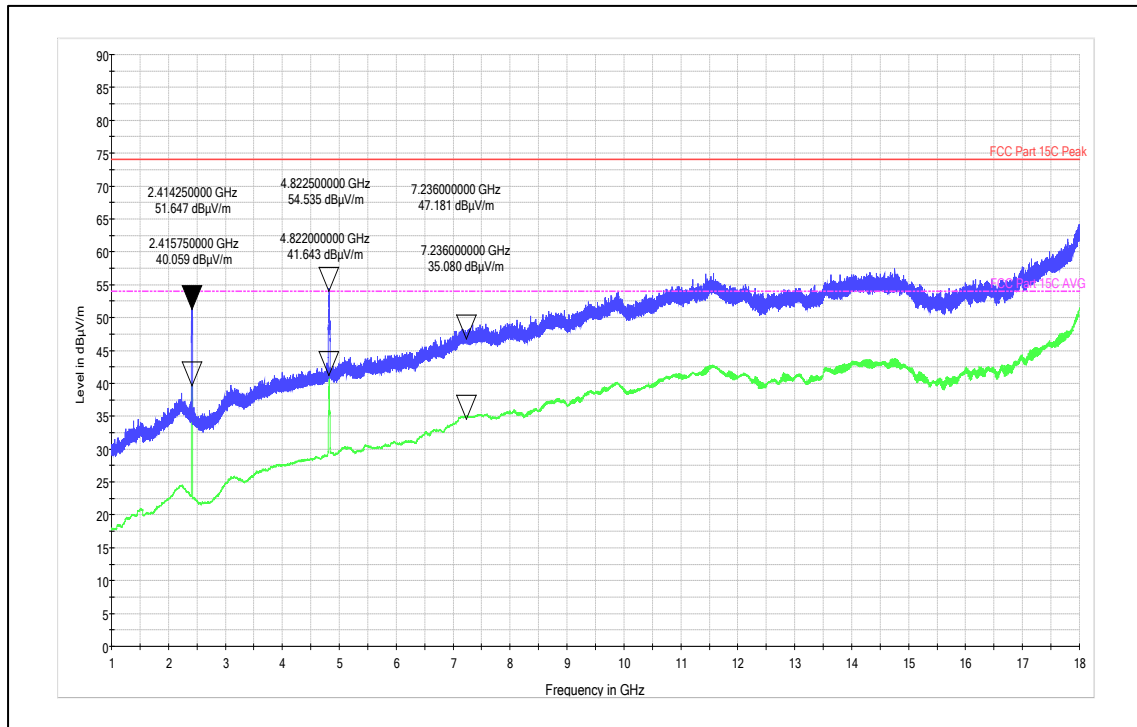

Channel Frequency: 1 - 18 GHz

Polarization: Vertical

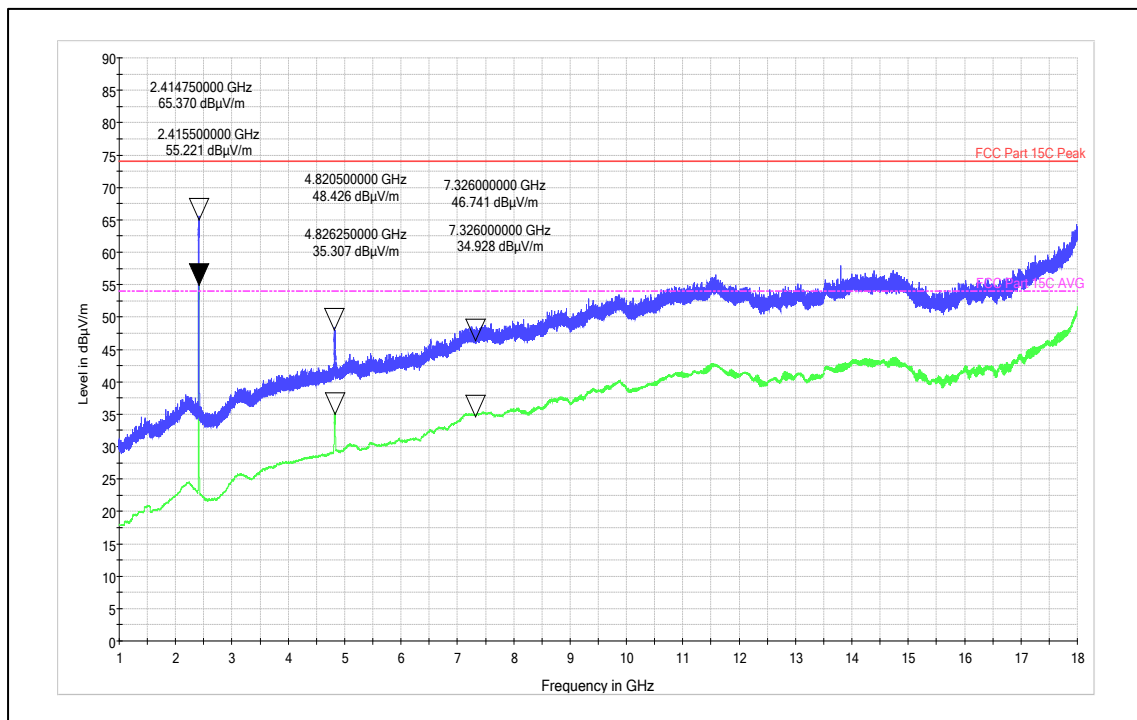

Channel Frequency: 1 - 18 GHz

Polarization: Horizontal

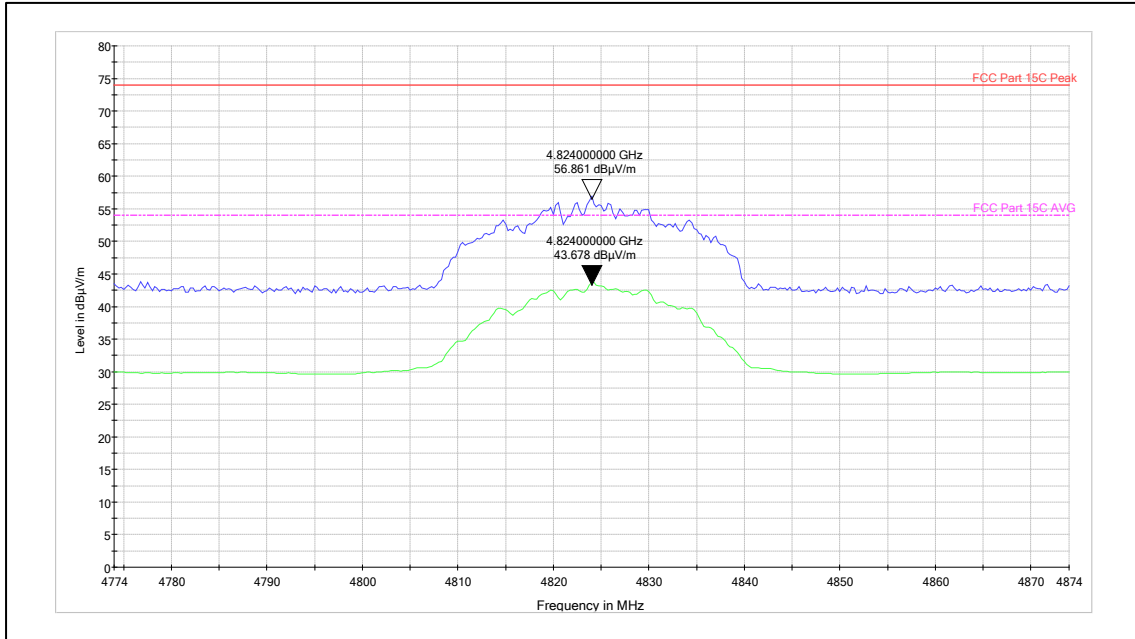

Channel Frequency: 2nd Harmonics

Polarization: Vertical

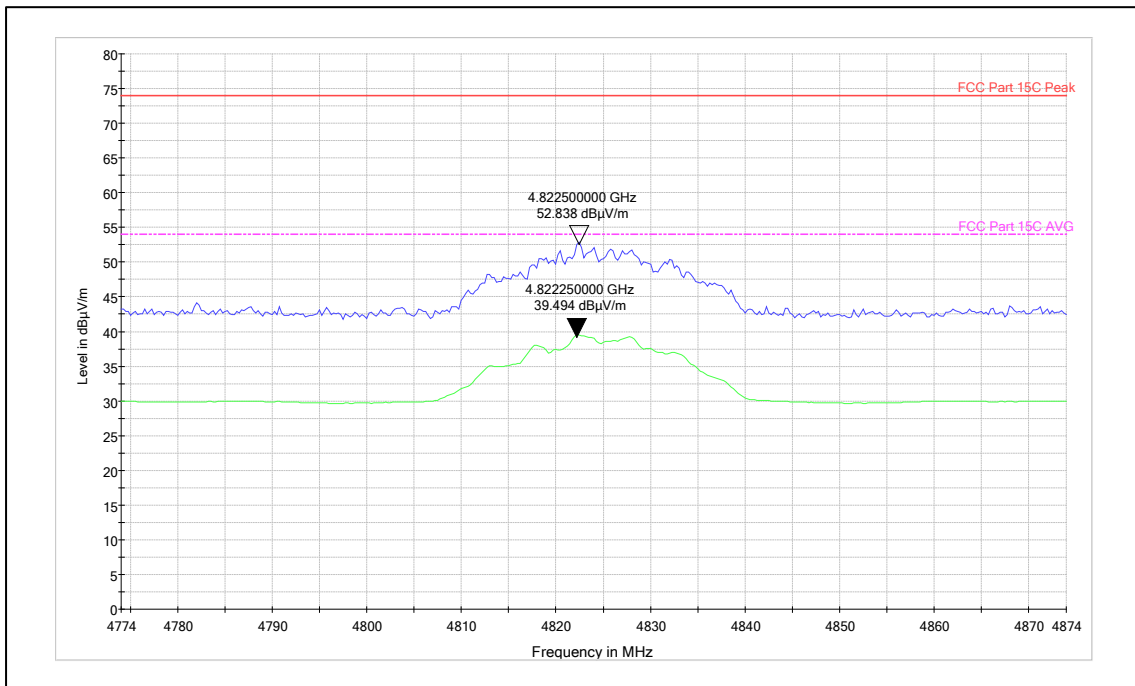

Channel Frequency: 2nd Harmonics

Polarization: Horizontal

Data Rate: MCS0_n Mode 20MHz

Channel Frequency 2437MHz

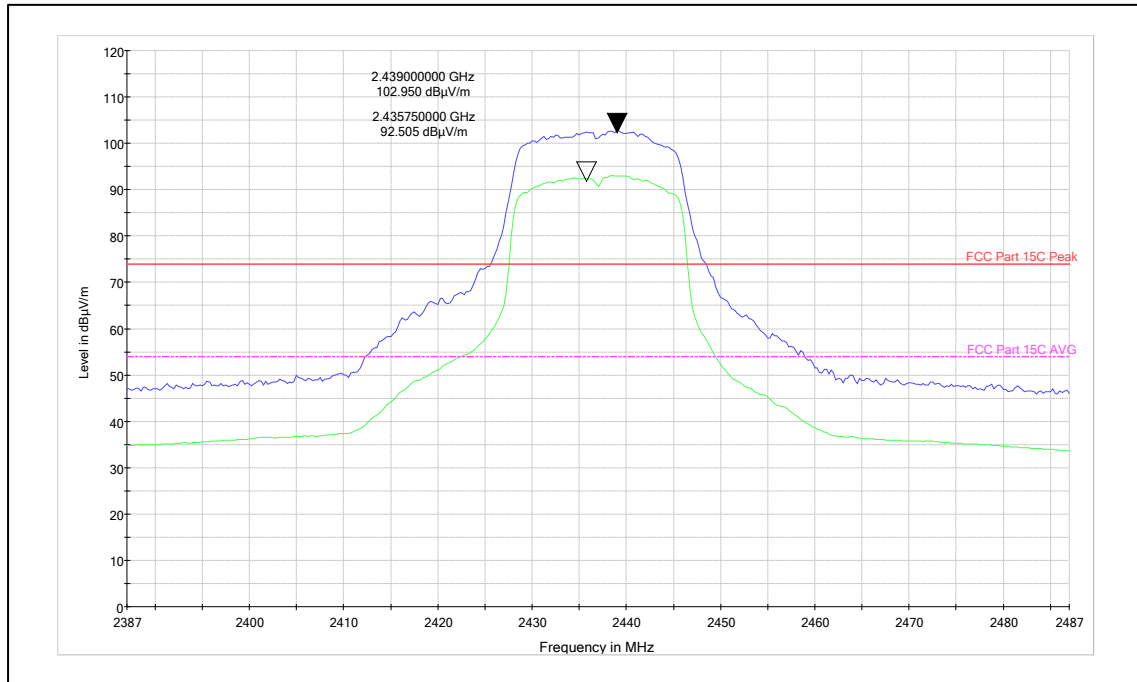

Channel Frequency: 2437MHz

Polarization: Vertical

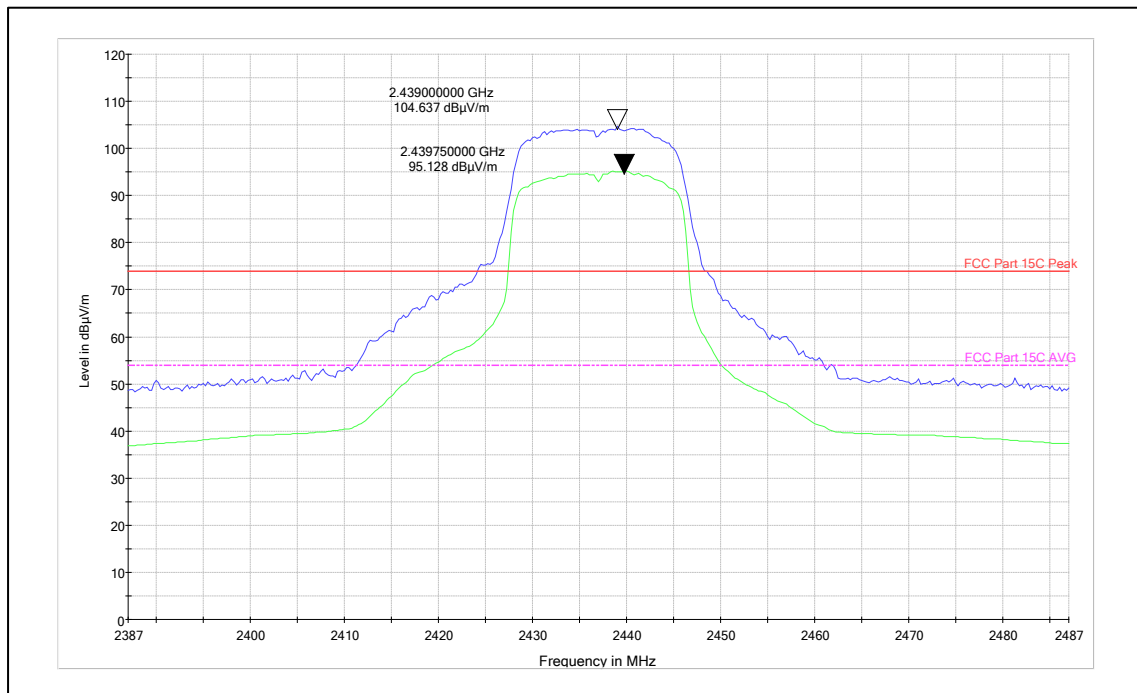

Channel Frequency: 2437MHz

Polarization: Horizontal

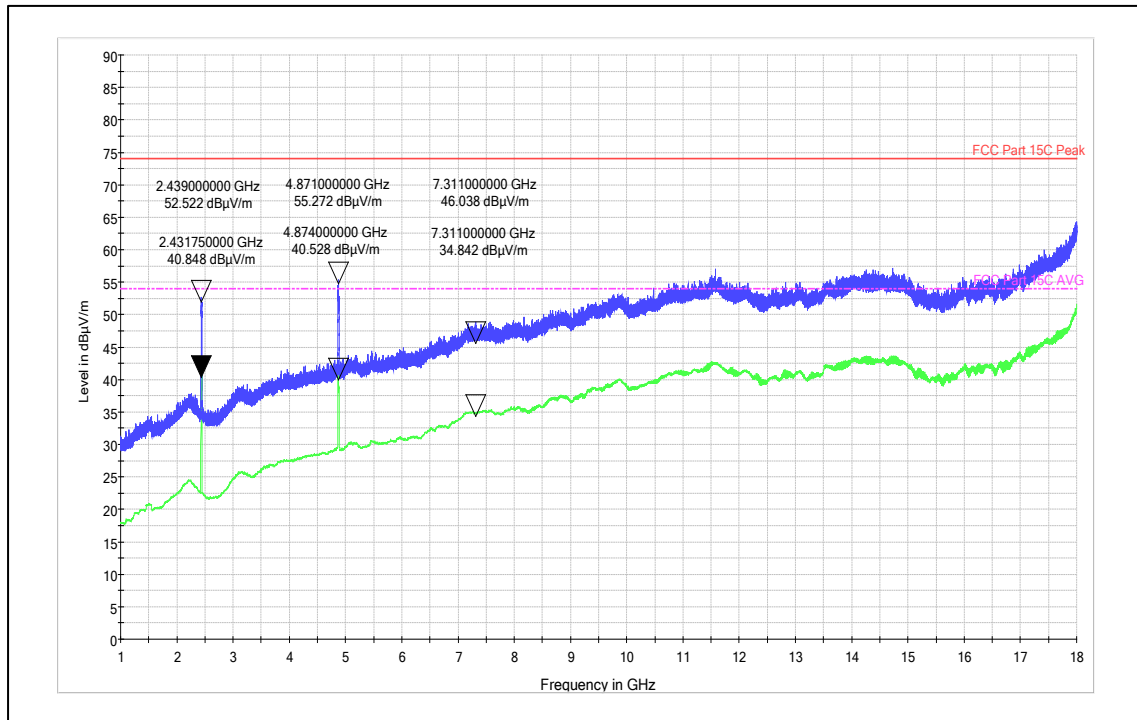

Channel Frequency: 1 - 18 GHz

Polarization: Vertical

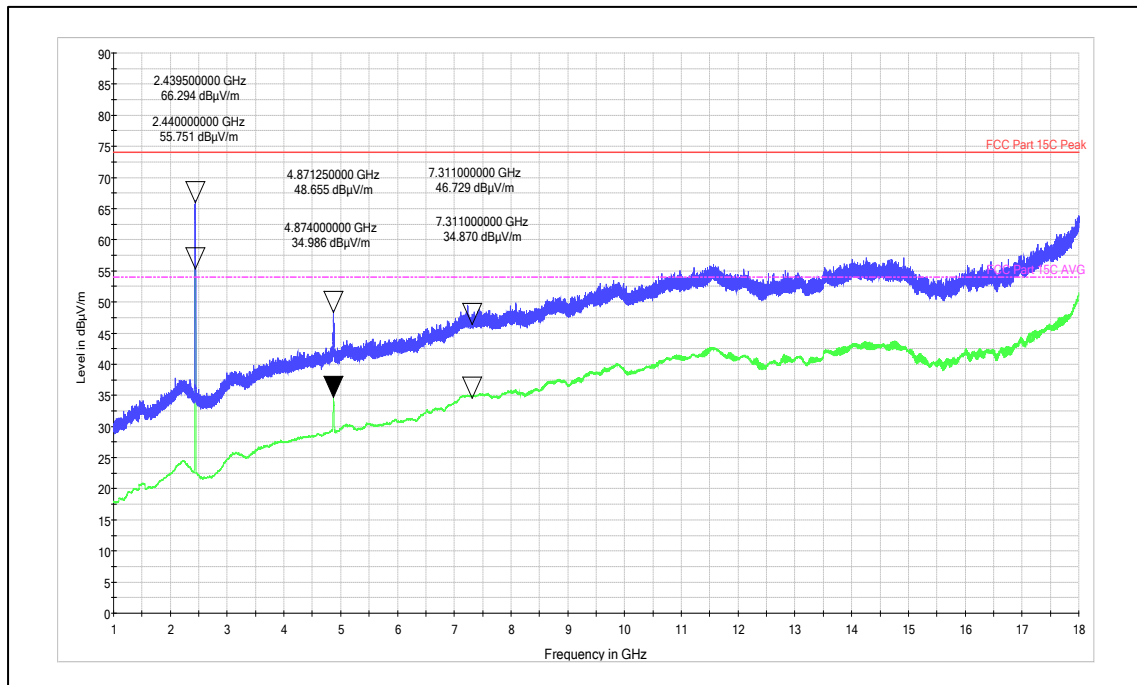

Channel Frequency: 1 - 18 GHz

Polarization: Horizontal

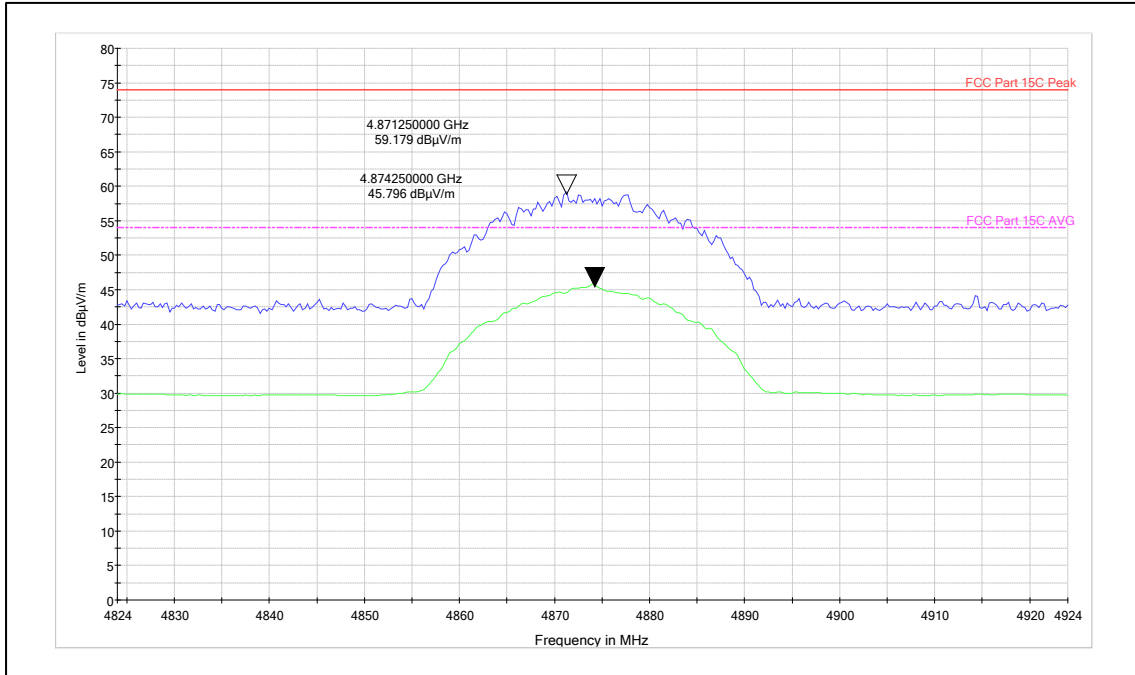

Channel Frequency: 2nd Harmonics

Polarization: Vertical

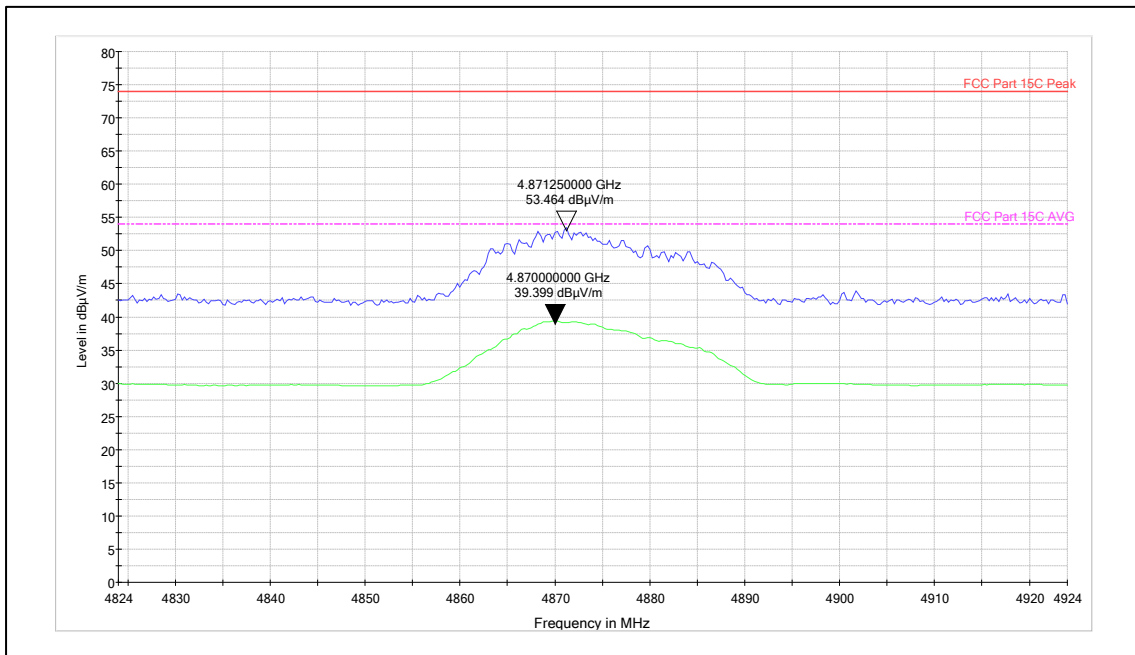

Channel Frequency: 2nd Harmonics

Polarization: Horizontal

Data Rate: MCS0_n Mode 40MHz

Channel Frequency 2422MHz

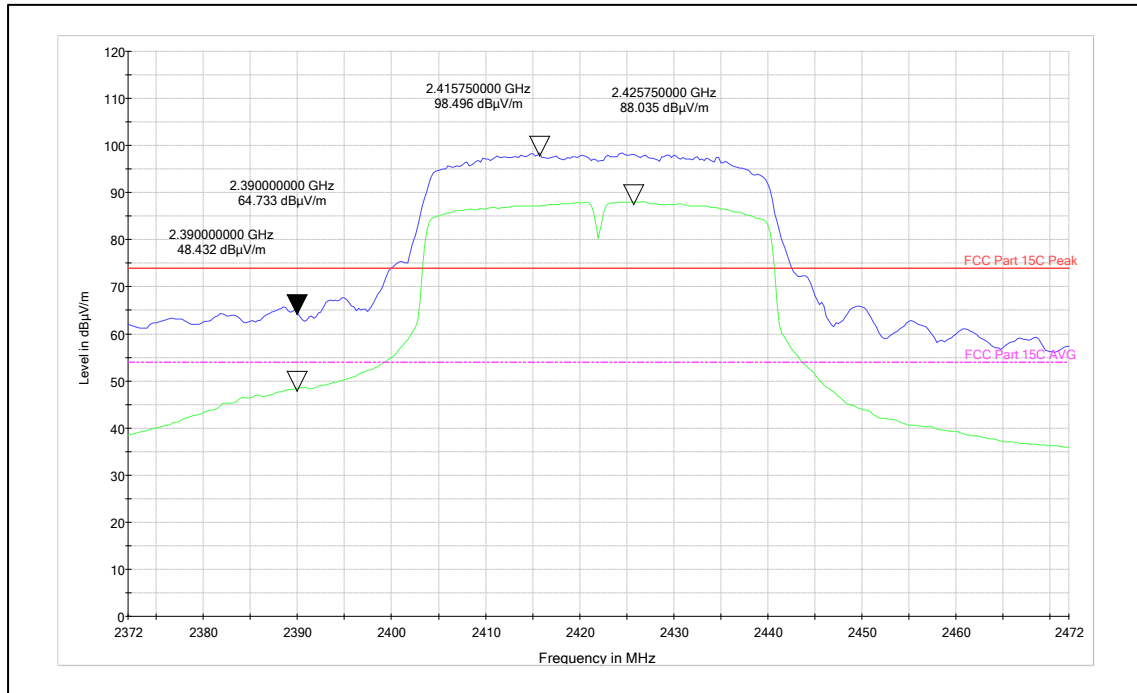

Channel Frequency: 2422MHz

Polarization: Vertical

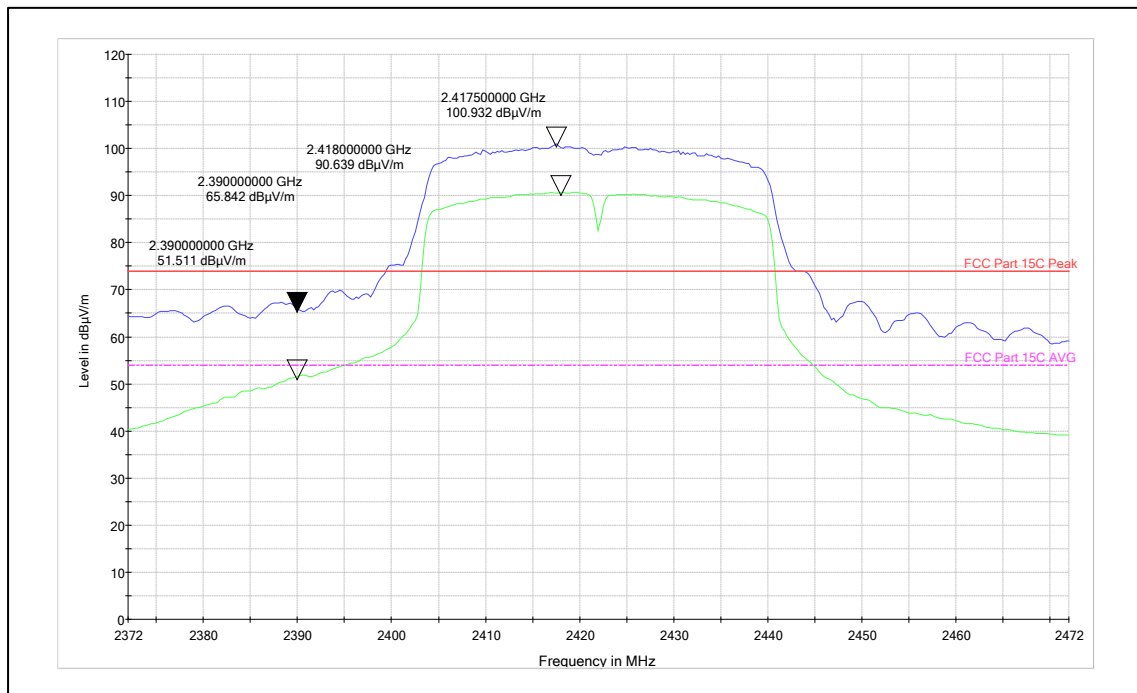

Channel Frequency: 2422MHz

Polarization: Horizontal

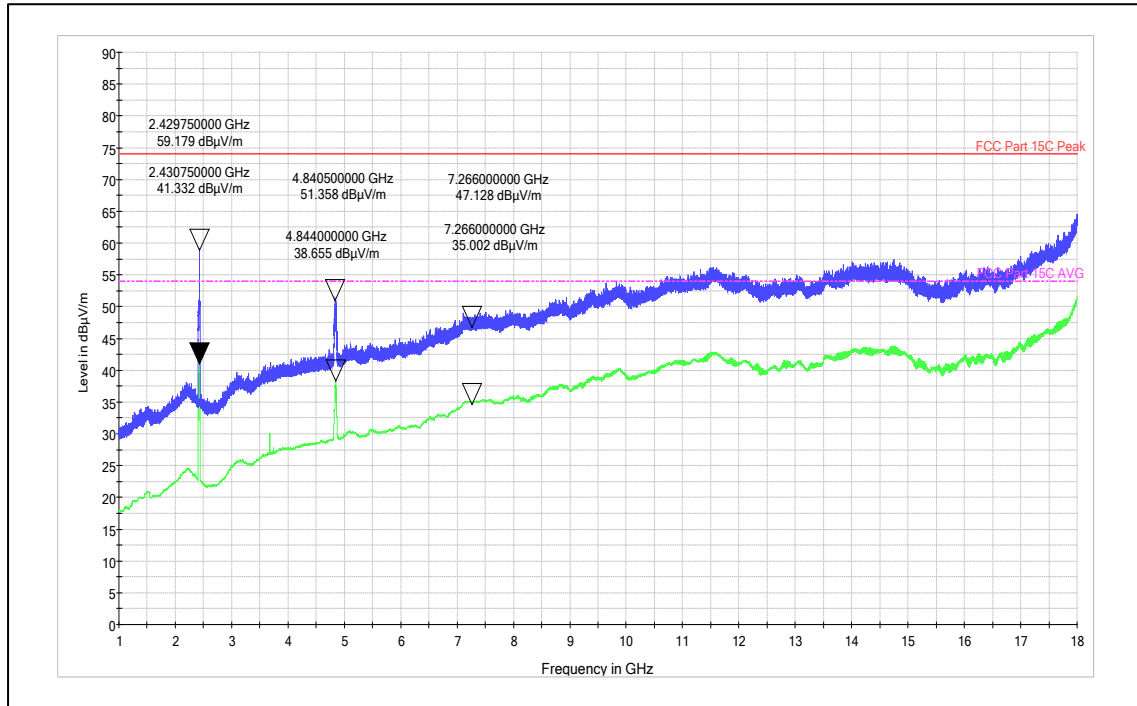

Channel Frequency: 1 - 18 GHz

Polarization: Vertical

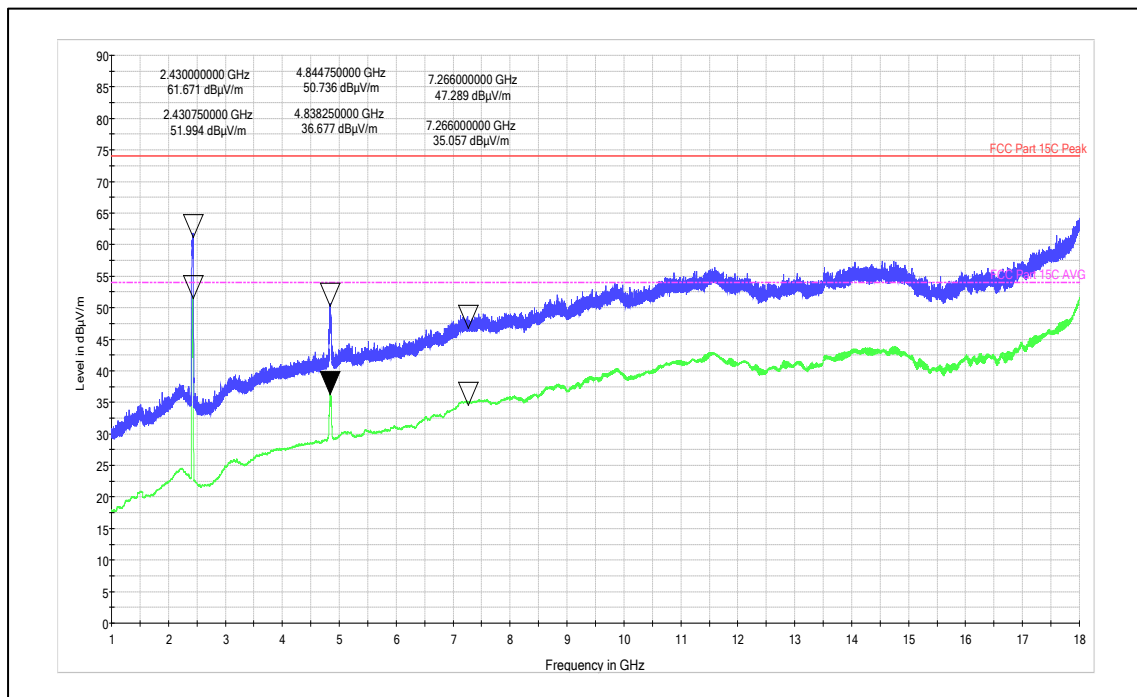

Channel Frequency: 1 - 18 GHz

Polarization: Horizontal

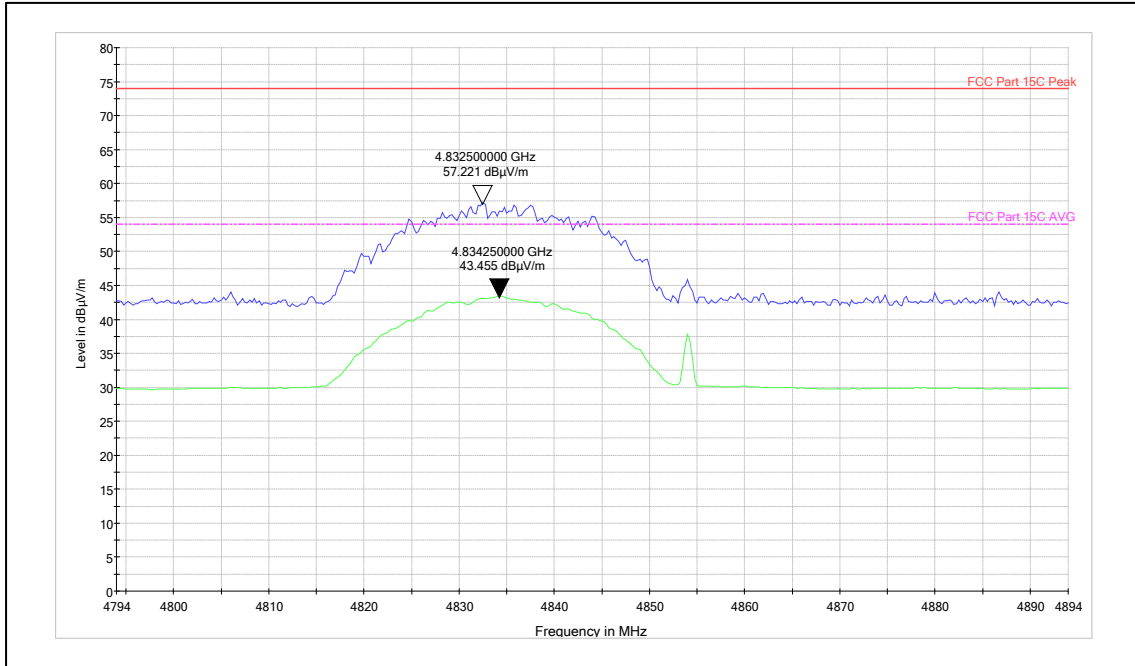

Channel Frequency: 2nd Harmonics

Polarization: Vertical

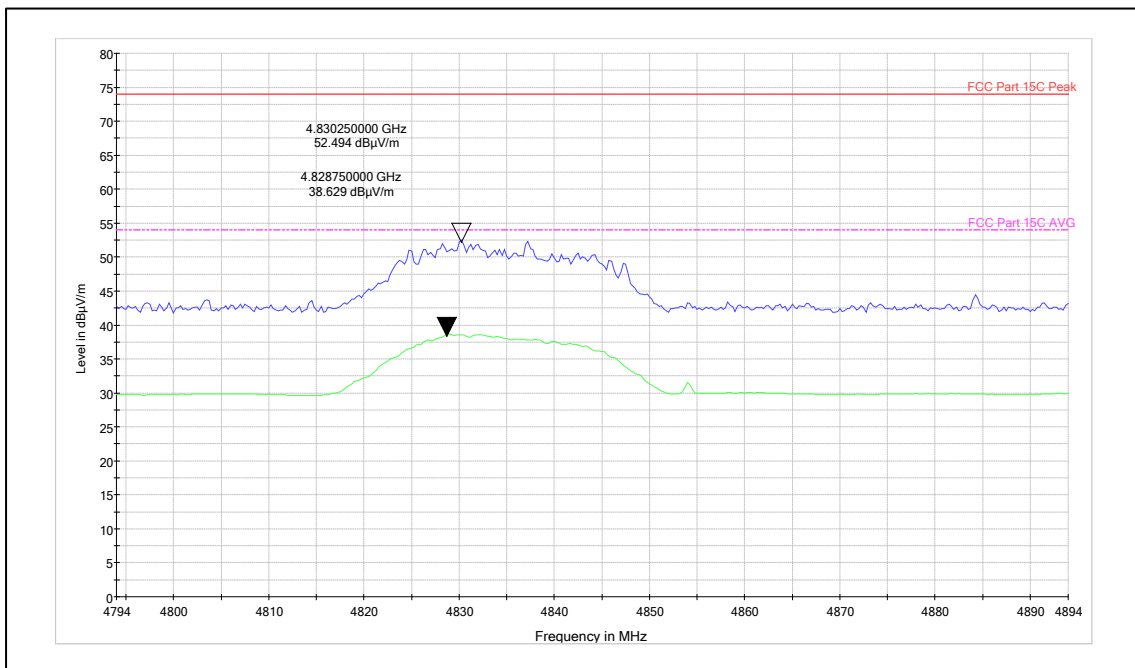

Channel Frequency: 2nd Harmonics

Polarization: Horizontal

9 TEST RESULTS FOR BLUETOOTH LOW ENERGY

9.1 Spurious Radiated Emissions & Restricted Bands of Operation

<i>Result</i>	<i>Pass</i>
Test Specification	FCC part 15 Subpart C 15.247 (d) / (15.209 & 15.205) / IC RSS-GEN, Section 8.9 and 8.10
Test Method	ANSI C63.10
Measurement Location	Semi Anechoic Chamber 30MHz - 1 GHz Fully Anechoic Chamber 1 GHz - 40GHz
Measurement Bandwidth	100 kHz for frequency range < 1GHz 1 MHz for Frequency range >1GHz
Detector	Refer remarks below
Measuring Distance	3 m
Requirement	As per the limits mentioned in the below table
Test setup	Refer TEST METHODOLOGY

Table 8: Transmitter limits for Radiated emission

Frequency (MHz)	Field strength (μV/m)	Field strength (dBμV/m)	Distance of Measurement (m)
0.009 – 0.490	2400/F(kHz)	48.50 – 13.80	300*
0.490 – 1.705	24000/F(kHz)	33.80 – 23.00	30*
1.705 -30	30	29.54	30*
30-88	100	40.0	3
88-216	150	43.5	3
216-960	200	46.0	3
Above 960	500	54.0	3

Remark: * The limit shows in the table above of frequency range 0.009 – 0.490, 0.490 – 1.705 MHz and 1.705-30MHz is at 300 meter, 30 meter and 30 meter range respectively, which corresponds to 128.51 – 93.80, 73.80 – 62.96 and 69.54 dBμV/m at 3m range by extrapolation calculation and the measurement of loop antenna.

The emission limits shown in the above table are based on measurements employing a CISPR quasi-peak detector except for the frequency bands 9–90 kHz, 110–490 kHz and above 1000 MHz Radiated emission limits in these three bands are based on measurements employing an average detector.

Test Conditions:

Temperature (Norm) = + 23.5 °C

Voltage = 4.2VDC input

Relative humidity = 64 %

Prüfbericht - Nr.:
Test Report No.:

ULR-TC568820300000037F

Seite 38 von 45
Page 38 of 45

Test results:

Note: All the losses are included during measurement and final values are mentioned in the test report. Refer TEST METHODOLOGY for more details

Test results for frequency range 9kHz – 30MHz

No emissions found in frequency range 9 kHz to 30 MHz, and measured levels are below 20dB from the limit line, hence not reported

Test results for frequency range 30MHz – 200MHz

Antenna Polarization	Frequency (MHz)	Peak (dBµV/m)	Limit (dBµV/m)	Margin (dB)
Vertical	35.28	17.39	40.00	-22.61
	44.57	18.51	40.00	-21.49
	93.38	20.02	43.50	-23.48
	184.94	25.75	43.50	-17.75
Horizontal	32.12	11.24	40.00	-28.76
	37.65	10.93	40.00	-29.07
	92.53	22.08	43.50	-21.42
	186.88	28.54	43.50	-14.96

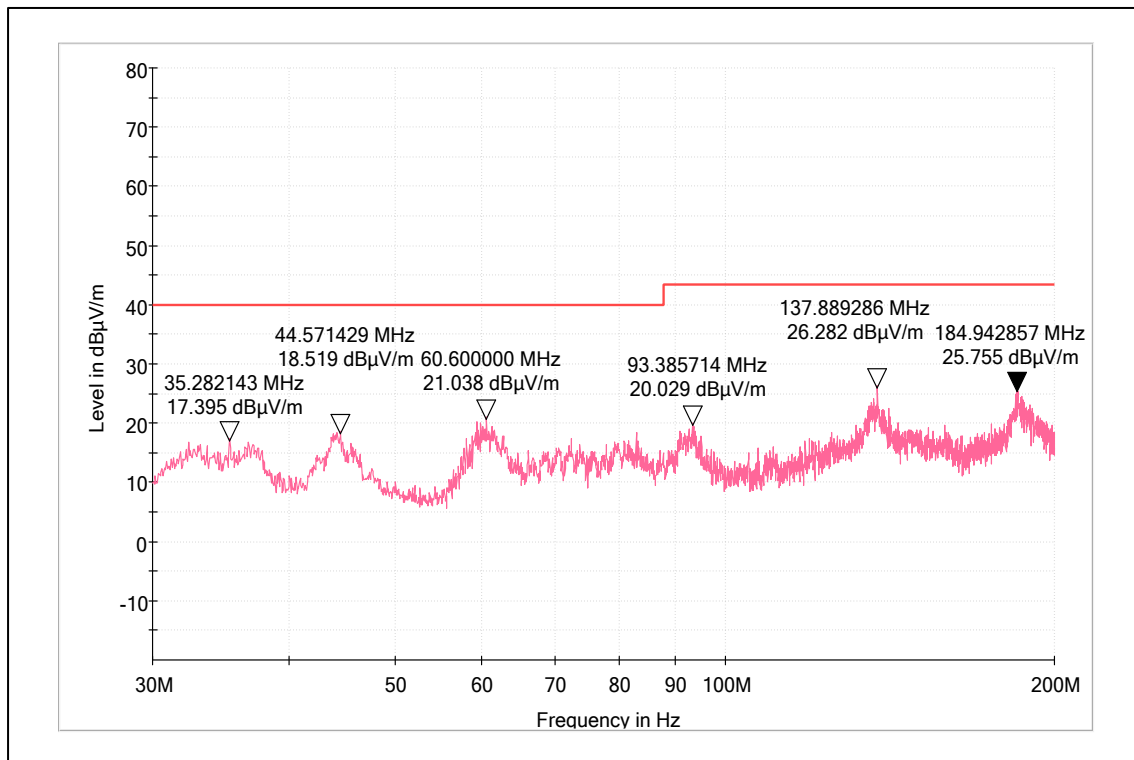

Channel Frequency 30MHz – 200MHz

Polarization Vertical

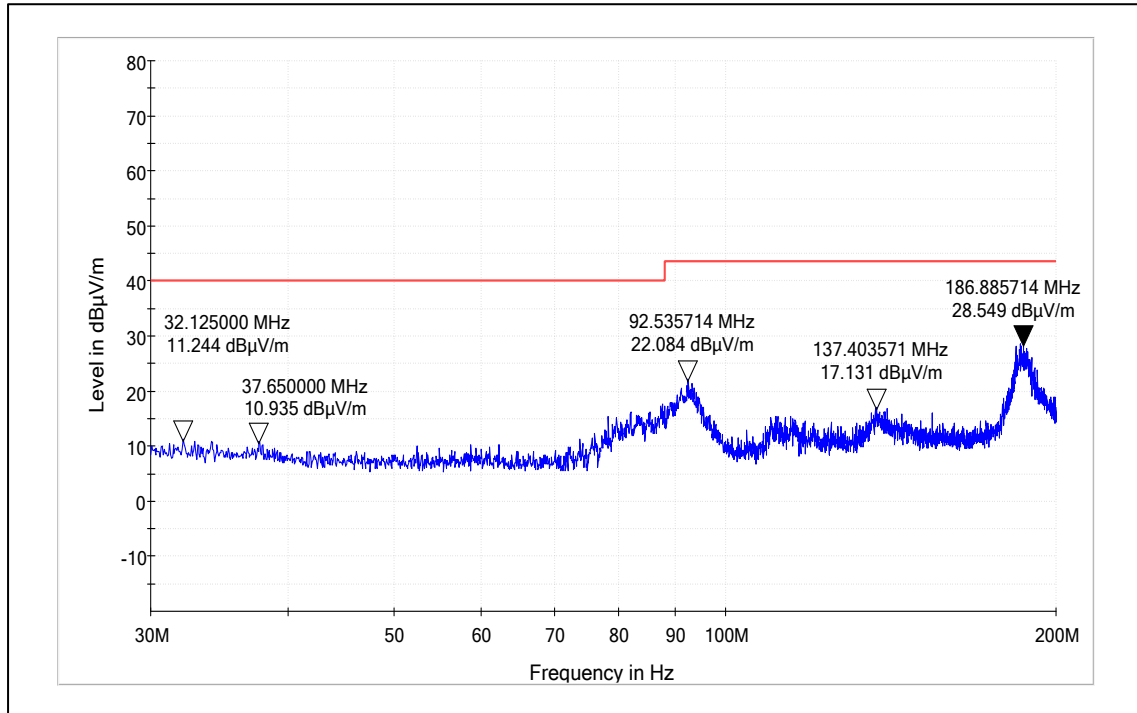

Channel Frequency 30MHz – 200MHz

Polarization Horizontal

Test results for frequency range 200MHz – 1GHz

Antenna Polarization	Frequency (MHz)	Peak (dBµV/m)	Limit (dBµV/m)	Margin (dB)
Vertical	235.80	32.53	46.00	-13.47
	272.63	28.69	46.00	-17.31
	567.12	22.05	46.00	-23.95
	839.76	31.73	46.00	-14.27
Horizontal	233.29	26.81	46.00	-19.19
	384.01	25.70	46.00	-20.3
	623.67	23.50	46.00	-22.5
	832.50	25.73	46.00	-20.27

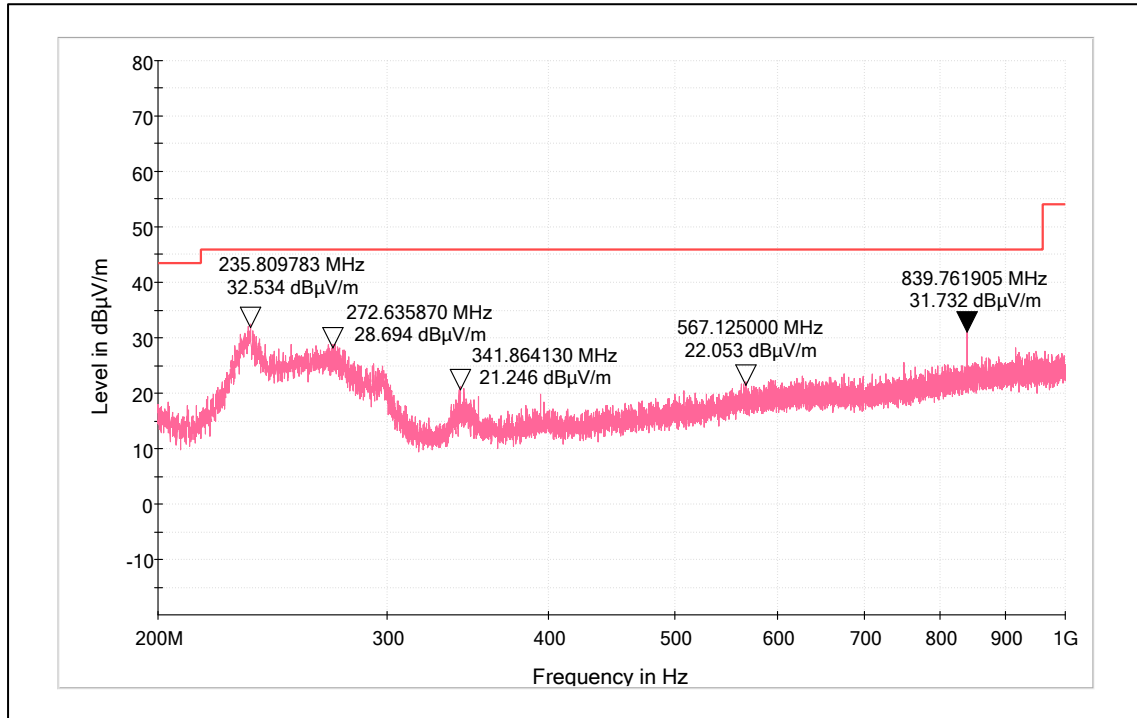

Channel Frequency 200MHz – 1GHz

Polarization Vertical

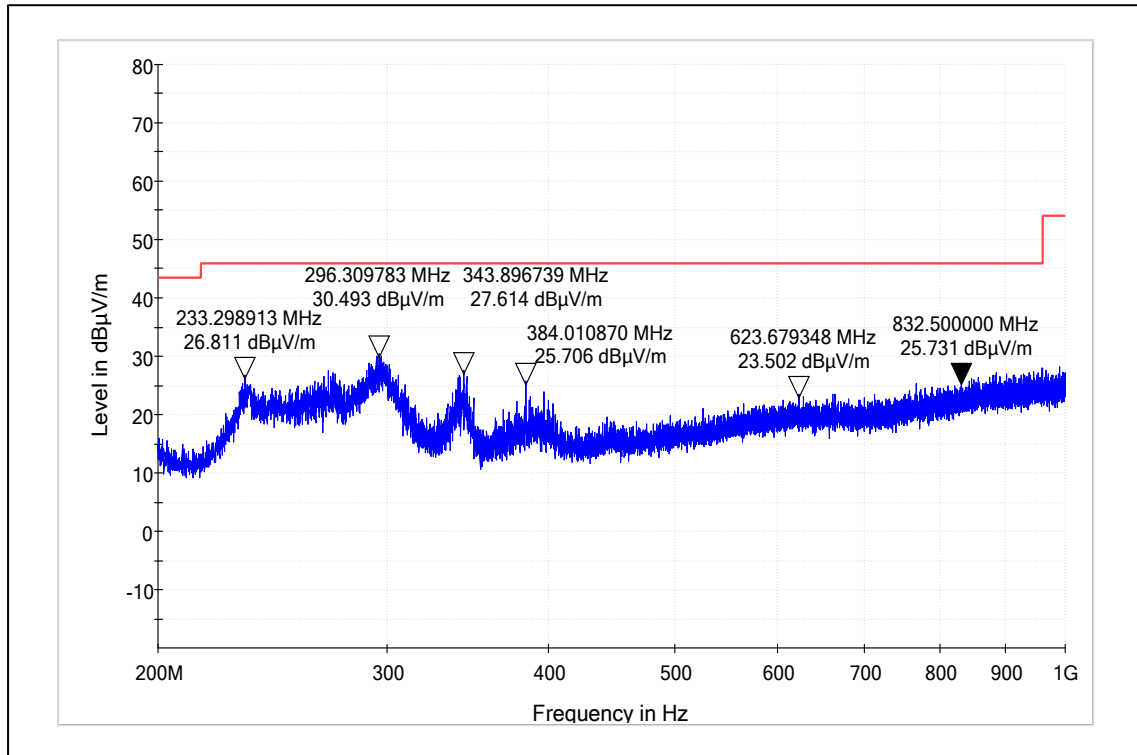

Channel Frequency 200MHz – 1GHz

Polarization Horizontal

Test results for the frequencies above 1GHz

Channel Frequency (MHz)	Antenna Polarization	Measured Frequency (MHz)	Field Strength (dBµV/m)	Limit (dBµV/m)	Margin (dB)
2402	V	2390(Pk)	38.04	74*	-35.96
		2390(Av)	85.67	54*	31.67
		2402(Pk)	90.34	-	-
		2402(Av)	85.67	-	-
		4804(Pk)	36.94	74	-37.06
		4804(Av)	28.39	54	-25.61
		7206(Pk)	No Harmonics Found		
	7206(Av)	No Harmonics Found			
	H	2390(Pk)	41.55	74*	-32.45
		2390(Av)	25.86	54*	-28.14
		2402(Pk)	98.80	-	-
		2402(Av)	94.13	-	-
		4804(Pk)	35.29	74	-38.71
		4804(Av)	23.44	54	-30.56
7206(Pk)		No Harmonics Found			
7206(Av)	No Harmonics Found				
2440	V	2440(Pk)	89.86	-	-
		2440(Av)	85.16	-	-
		4880(Pk)	42.60	74	-31.40
		4880(Av)	30.03	54	-23.97
		7320(Pk)	No Harmonics Found		
	7320(Av)	No Harmonics Found			
	H	2440(Pk)	97.90	-	-
		2440(Av)	92.16	-	-
		4880(Pk)	44.48	74	-29.52
		4880(Av)	30.68	54	-23.32
7320(Pk)		No Harmonics Found			
7320(Av)	No Harmonics Found				
2480	V	2480(Pk)	90.73	-	-
		2480(Av)	86.03	-	-
		2483.5(Pk)	42.16	74*	-31.84
		2483.5(Av)	25.40	54*	-28.60
		4960(Pk)	43.61	74	-30.39
		4960(Av)	31.78	54	-22.22
		7440(Pk)	No Harmonics Found		
	7440(Av)	No Harmonics Found			
	H	2480(Pk)	97.28	-	-
		2480(Av)	92.54	-	-
		2483.5(Pk)	46.70	74*	-27.30
		2483.5(Av)	28.01	54*	-25.99
		4960(Pk)	44.48	74	-29.52
		4960(Av)	30.68	54	-23.32
7440(Pk)		No Harmonics Found			
7440(Av)	No Harmonics Found				

* : Indicate restricted band of operation §15.205
Pk: Peak Detector; Av: Average Detector

Worst case Plots
Channel Frequency 2402MHz

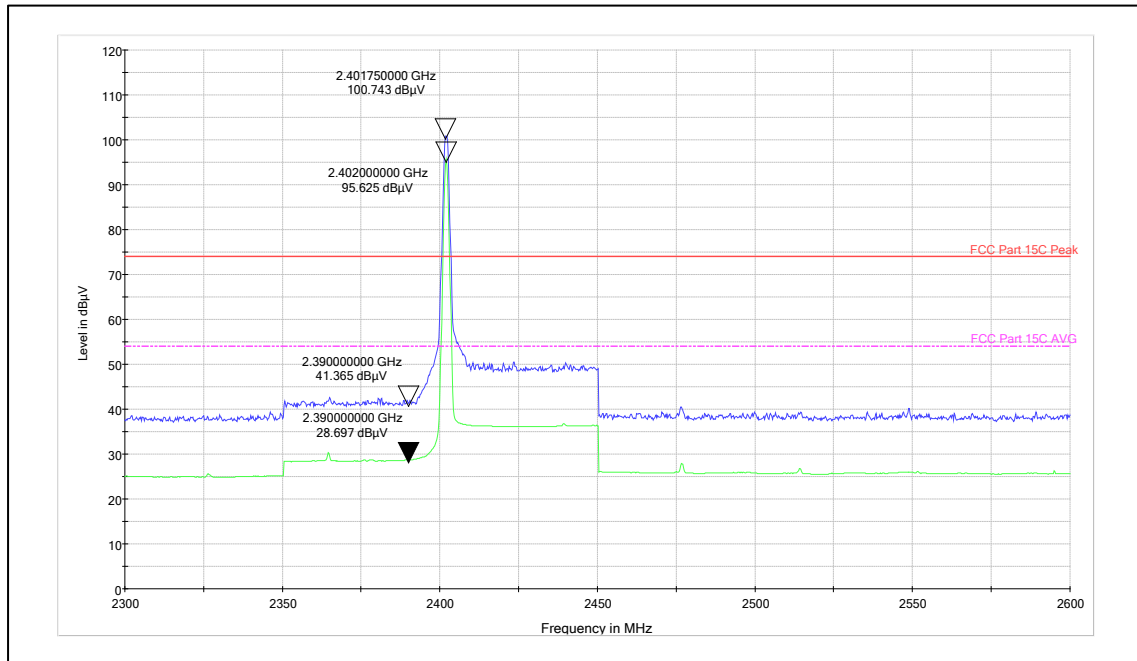

Channel Frequency: 2402MHz

Polarization: Vertical

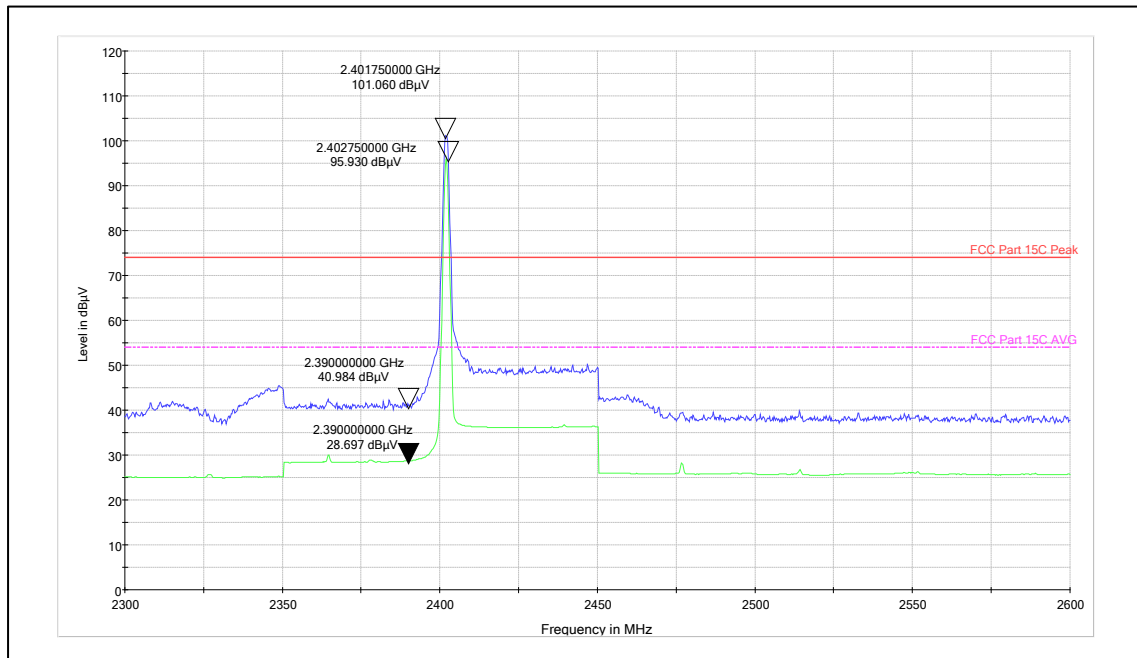

Channel Frequency: 2402MHz

Polarization: Horizontal

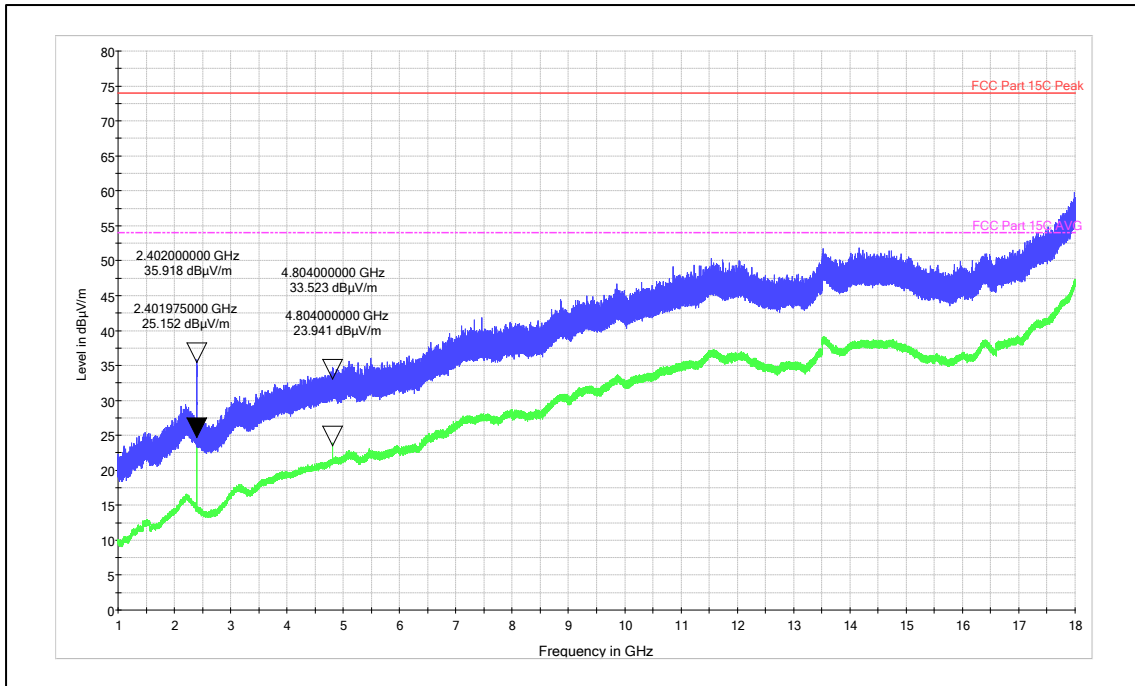

Channel Frequency: 1-18GHz

Polarization: Vertical

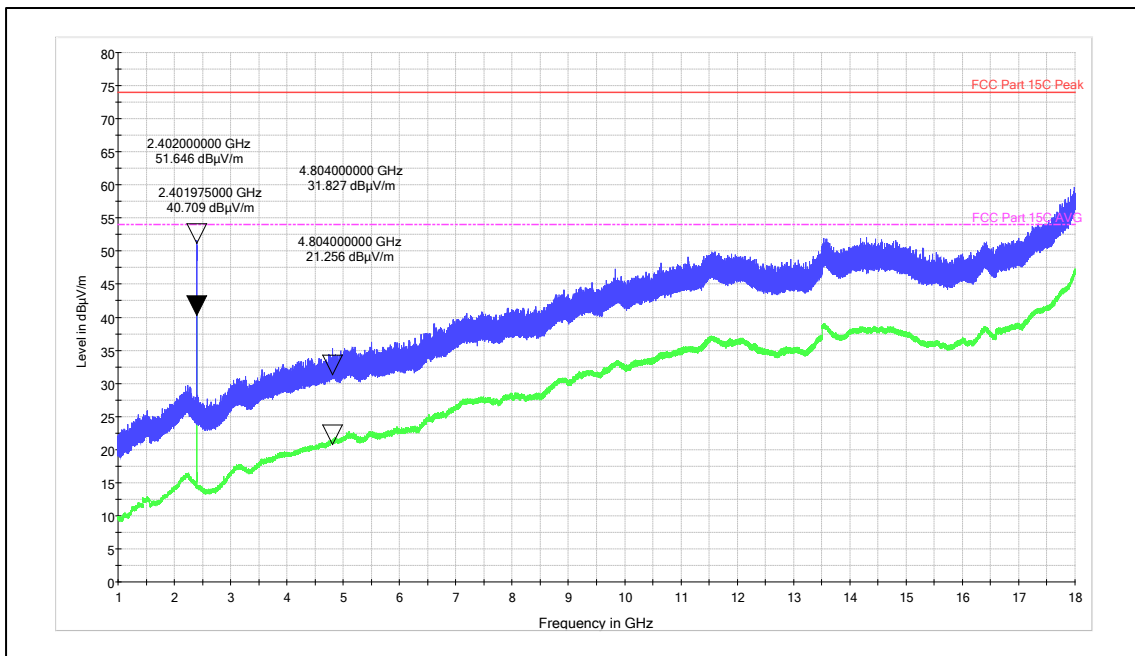

Channel Frequency: 1-18GHz

Polarization: Horizontal

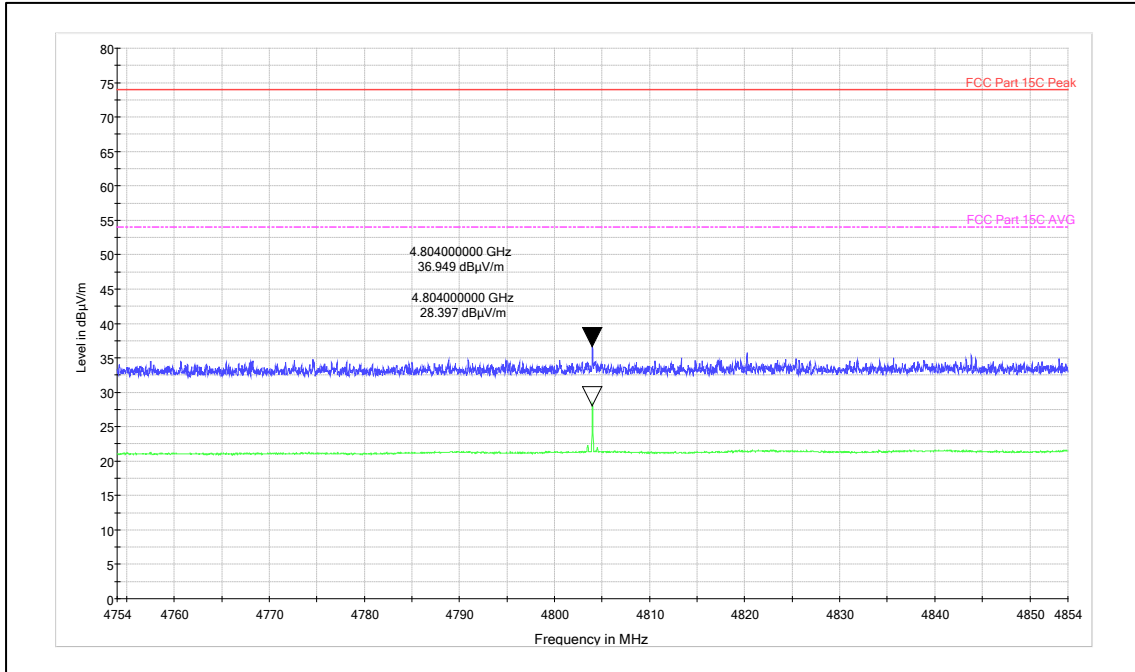

Channel Frequency: 2nd Harmonics

Polarization: Vertical

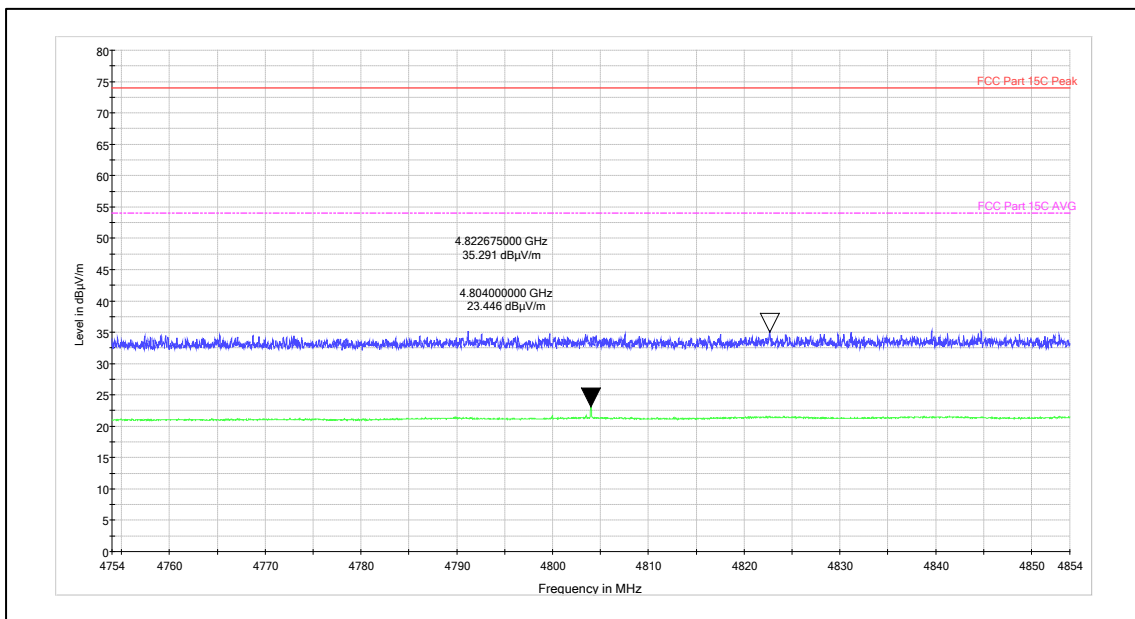

Channel Frequency: 2nd Harmonics

Polarization: Horizontal

10 LIST OF TABLES

Table 1: List of test and measurement instruments	6
Table 2: Instrument application Software versions	7
Table 3: Ratings and System Details as declared by Client*	8
Table 4: Measurement Uncertainty	9
Table 5: List of Wi-Fi center Frequencies	11
Table 6: List of BLE Center frequencies	11
Table 7: Transmitter limits for Radiated emission	16
Table 8: Transmitter limits for Radiated emission	37

11 List of Figures

Figure 1: Frequency Range 9 kHz- 30 MHz	14
Figure 2: Frequency Range 30 MHz – 200 MHz	14
Figure 3: Frequency Range 200 MHz - 1GHz	15
Figure 4: Frequency Range above 1 GHz	15

END OF TEST REPORT