



Prüfbericht-Nr.: <i>Test report no.:</i>	ULR- TC568820300000039F	Auftrags-Nr.: <i>Order no.:</i>	166203252 0030	Seite 1 von 43 Page 1 of 43	
Kunden-Referenz-Nr.: <i>Client reference no.:</i>	NA	Auftragsdatum: <i>Order date:</i>	2019-11-26		
Auftraggeber: <i>Client:</i>	Mistral Solutions Private Limited 60 Adarsh Regent, 100 feet ring road Domlur Extension, Bangalore-560071,India				
Prüfgegenstand: <i>Test item:</i>	SD820 Nano SOM with 2x2 802.11 a/b/g/n/ac WIFI+ Bluetooth Module				
Bezeichnung / Serien -Nr.: <i>Identification / Serial no.:</i>	SD820 Nano SOM Rev B				
Auftrags-Inhalt: <i>Order content:</i>	Testing & Issue of Test Report and FCC Grant				
Prüfgrundlage: <i>Test specification:</i>	FCC Part 15 Subpart E 15.407,15.207&15.209 & RSS 247 Issue 2 and RSS GEN Issue 5				
Wareneingangsdatum: <i>Date of sample receipt:</i>	2020-03-10				
Prüfmuster-Nr.: <i>Test sample no:</i>	A001073243-001 A001073243-002				
Prüfzeitraum: <i>Testing period:</i>	2020-08-24 - 2020-08-28				
Ort der Prüfung: <i>Place of testing:</i>	Wireless laboratory, Bangalore				
Prüflaboratorium: <i>Testing laboratory:</i>	TÜV Rheinland (India) Pvt.Ltd., 27/B, 2nd Cross, ElectronicCityPhase1 Bangalore – 560 100, India				
Prüfergebnis*: <i>Test result*:</i>	Pass				
geprüft von: <i>tested by:</i>		genehmigt von: <i>authorized by:</i>			
Datum: <i>Date:</i>	2020-11-29	Ausstellatum: <i>Issue date:</i>	2020-11-29		
Stellung / Position:	Madhu Karadekere Nagaraju Senior Engineer	Stellung / Position:	Mahammadgouse Kaladagi Assistant Manager		
Sonstiges / Other:	ULR – TC568820300000039F FCC ID: 2AVEC-QCNFA324 IC ID: 26058-QCNFA324				
Zustand des Prüfgegenstandes bei Anlieferung: <i>Condition of the test item at delivery:</i>	Prüfmuster vollständig und unbeschädigt <i>Test item complete and undamaged</i>				
* Legende:	1 = sehr gut P(ass) = entspricht o.g. Prüfgrundlage(n)	2 = gut F(ail) = entspricht nicht o.g. Prüfgrundlage(n)	3 = befriedigend F(ail) = entspricht nicht o.g. Prüfgrundlage(n)	4 = ausreichend N/A = nicht anwendbar	5 = mangelhaft N/T = nicht getestet
* Legend:	1 = very good P(ass) = passed a.m. test specification(s)	2 = good F(ail) = failed a.m. test specification(s)	3 = satisfactory F(ail) = failed a.m. test specification(s)	4 = sufficient N/A = not applicable	5 = poor N/T = not tested
<p>Dieser Prüfbericht bezieht sich nur auf das o.g. Prüfmuster und darf ohne Genehmigung der Prüfstelle nicht auszugsweise vervielfältigt werden. Dieser Bericht berechtigt nicht zur Verwendung eines Prüfzeichens. <i>This test report only relates to the a. m. test sample. Without permission of the test center this test report is not permitted to be duplicated in extracts. This test report does not entitle to carry any test mark.</i></p>					

V05

TEST SUMMARY

Test Item	Applicable Standard		Result
	FCC	ISED	
Maximum conducted output power	15.407 (a)	RSS 247 Issue 2 Clause 6.2	*N/T
Emission Bandwidth	15.407 (a) & (e)	RSS Gen Issue 5 Section 6.7 RSS 247 Issue 2 Section 6.2.4.1	*N/T
Frequency Stability	15.407 (g)	RSS Gen Issue 5 Section 8.11	*N/T
Maximum Power spectral density	15.407 (a)	RSS 247 Issue 2 Section 6.2.1.1 & Section 6.2.4.1	*N/T
Spurious Radiated Emissions & Restricted Bands of Operation	15.407 (b) / (15.205 & 15.209)	RSS 247 Issue 2 Section 6.2.1.2 & 6.2.4.2 RSS Gen Issue 5 Section 8.9 & 8.10	Pass
Conducted AC Power Lines	15.207	RSS Gen Issue 5 Section 8.8	NA

Product Category: Electronics Testing
Test Discipline : EMC Test Facility

NA: Not Applicable

*N/T: Not tested – These test cases are not tested, the product uses certified RF module **QCNFA324** from **Qualcomm Atheros, Inc.**, with **FCC ID: PPD-QCNFA324** & **IC ID: 4104A-QCNFA324**.

REVISION HISTORY OF THIS REPORT

Report Number	Version	Description	Issue date
ULR-TC568820300000039F	01	Initial issue of report	07.10.2020
ULR-TC568820300000039F	02	Reviwer comments updated	29.11.2020

Table of Contents

1	GENERAL REMARKS	5
1.1	Attachments	5
2	TEST SITES	6
2.1	Testing Facilities.....	6
2.2	List of Test and Measurement Instruments.....	6
3	GENERAL PRODUCT INFORMATION.....	8
3.1	Product Function and Intended Use.....	8
3.2	Ratings and System Details of Equipment under Test	8
3.3	Measurement Uncertainty:	9
4	TEST SET-UP AND OPERATION MODE	10
4.1	Principle of Configuration Selection	10
4.2	Test Operation and Test Software	10
4.3	Special Accessories and Auxiliary Equipment	10
4.4	Countermeasures to achieve EMC Compliance	10
4.5	Simultaneous Transmission	10
4.6	List of frequencies	11
4.7	TUV Sample Identification number	12
4.8	Report Reference	12
5	Operational Description	13
6	Block Diagram.....	13
7	TEST METHODOLOGY	14
7.1	Radiated Emission Test	14
7.1.1	Test Setup Configuration	14
8	TEST RESULTS FOR Wi-Fi-5GHz.....	16
8.1	Spurious Radiated Emissions & Restricted Bands of Operation	16
9	LIST OF TABLES.....	43
10	List of Figures.....	43

1 GENERAL REMARKS

1.1 Attachments

All attachments are part of this test report and are issued in separate document

1. TEST SETUP PHOTOS
2. EUT EXTERNAL PHOTOS
3. EUT INTERNAL PHOTOS
4. FCC LABEL AND LABEL LOCATION
5. BLOCK DIAGRAM
6. SPECIFICATION OF EUT
7. SCHEMATIC DIAGRAMS
8. BILL OF MATERIAL
9. USER MANUAL
10. Maximum Permissible Exposure Information

2 TEST SITES

2.1 Testing Facilities

1. TÜV Rheinland (India) Private Limited.
27/B, 2nd Cross,
Electronic City Phase1
Bangalore – 560 100,
India
2. TUV Rheinland (India) Private Limited.
108 , Beside ISBR Business School,
Electronic City Phase1
Bangalore - 560 100.
India

2.2 List of Test and Measurement Instruments

Table 1: List of test and measurement instruments

Equipment	Manufacturer	Model Name	Serial Number	Firmware Versions	Calibration Due Date	Periodicity	Test Facility
EMI Receiver	Rohde & Schwarz	ESU 40	100288	4.43 SP3	09.06.2021	Yearly	Radiated Spurious Emission
Active loop antenna	Schwarzbeck	FMZB 1519 B	1519B-00111	-	31.01.2021	Yearly	
Biconical Antenna	Schwarzbeck	VHBB91 24+BBA 9106	9124-1208+9106-0525	-	17.02.2021	Yearly	
Baloon and Biconical Antenna	Schwarzbeck mess-elektronik	VHBB-9124 / BBA-9106	01028	-	02.09.2021	Yearly	
Log - Periodical Antenna	Schwarzbeck	VUSLP 9118 A	VULP911 8A-0733	-	13.02.2021	Yearly	
Horn Antenna	Schwarzbeck	BBHA 9170	BBHA 9170-0904	-	29.01.2021	Yearly	
Horn Antenna	Schwarzbeck	BBHA 9120 D	9120D-1944	-	30.01.2021	Yearly	
Semi Anechoic Chamber	Frankonia	-	-	-	-	-	
Fully Anechoic Chamber	Albatross	-	-	-	-	-	
EMI Receiver	Rohde & Schwarz	ESW 44	101732	-	10.12.2020	Yearly	

Prüfbericht - Nr.:
Test Report No.:

ULR-TC56882030000039F

Seite 7 von 43
Page 7 of 43

Table 2: Instrument application Software versions

SL. No.	Test Type	Application software	Version
1	Radiated spurious emission measurement in SAC	EMC 32	10.60.00
2	Radiated spurious emission measurement in FAC	EMC 32	10.60.00

3 GENERAL PRODUCT INFORMATION

3.1 Product Function and Intended Use

The 820 Nano SOM from Mistral is an easy to use, ultra-compact, light-weight System on Module providing very high processing power. The SOM is based on Qualcomm Snapdragon 820 and is ideal for advanced, next-gen embedded applications. With a PCB size of just 51mm x 26mm, this is one of the smallest Snapdragon based SOMs available in the market currently. Equipped with powerful specifications and features, the 820 Nano SOM is ideal for designs requiring 4K Ultra HD HEVC (H.265) video and graphics processing, wireless connectivity, low power consumption and advanced processing power. The feature-rich 820 Nano SOM supports latest features like Type-C functionality, 4K Encode/Decode and integrated 9-axis MEMS on a very small footprint, making it ideal for several powerful applications. The 820 Nano SOM is ideal for designing products like wearable computers, camera solutions, media gateways, Infotainment, drones, assistive devices and other smart gadgets requiring small package and high processing power.

3.2 Ratings and System Details of Equipment under Test

Table 3: Ratings and System Details as declared by the Client*

Radio Protocol	WI-FI-5GHz
Operating Frequency Range	UNII-1 _ 5180MHz to 5250MHz UNII-2a _ 5250MHz to 5350MHz UNII-2c _ 5475MHz to 5725MHz UNII-3 _ 5725MHz to 5850MHz
No. of Channels	17 (Refer Table 5)
Channel Spacing	5 MHz
Modulation	802.11b: CCK, DQPSK, DBPSK 802.11a/g: 64QAM,16QAM, QPSK, BPSK 802.11n: 64QAM,16QAM, QPSK, BPSK 802.11ac: 256QAM,64QAM,16QAM, QPSK, BPSK
Maximum Measured Power (e.i.r.p)	20.05 (1Mbps at 5320MHz)
Number of antennas	2
Frequency range of Antenna Gain	Peak gain(3.0dBi) Average gain(-2.5dBi)
Antenna Type	SMD Type, SR42W001
Supply Voltage to Product	4.2 V DC Supply
Environmental conditions	0°C to +70°C Relative Humidity <95%
EUT Dimension	51 x 26 x 1.63 mm (LxWxH)

***Disclaimer:** The information/data is supplied by the client and the same is considered to arrive at the final value. Any changes made apart from the specified specification, can directly impact on the tests results.

Note: Product SD820 Nano SOM- Wi-Fi Module has multiple protocols. All the supported wireless protocols and their respective test results are issued in separate test reports, refer clause 4.8 Report Reference

3.3 Measurement Uncertainty:

Reported uncertainties represent expanded uncertainties expressed at approximately the 95% confidence level using a coverage factor of $k = 2$

Table 4: Measurement Uncertainty

Parameter	Uncertainty
Occupied Channel Bandwidth	±5 %
RF output power, conducted	±1.5 dB
Power Spectral Density, conducted	±3 dB
Unwanted Emissions, conducted	±3 dB
All emissions, radiated	±6 dB
Temperature	±3 °C
Supply Voltages	±3 %
Time	±5 %

Note: The Listed Measurement Uncertainties are the worst-case uncertainty, for the respective test cases. Above Table is for reporting purpose only and not used in determining Final Pass/Fail verdict.

4 TEST SET-UP AND OPERATION MODE

4.1 Principle of Configuration Selection

Transmission enabled with highest possible duty cycle transmission on low, mid and high channel.

4.2 Test Operation and Test Software

Hardware Version: RevB
Hardware Version Identification Number(s) (HVIN): QCNFA324

Software Version: Andr_oreo_8.0
Firmware Version Identification Number(s) : eeprom_ar6320_3p0_NFA324i_5.bin

4.3 Special Accessories and Auxiliary Equipment

- Test laptop and USB cable

4.4 Countermeasures to achieve EMC Compliance

- None

4.5 Simultaneous Transmission

- Device support simultaneous transmission, measured levels under simultaneous Transmission are same as the stand- alone transmission hence not reported

4.6 List of frequencies

Frequency Band (MHz)	Channel No.	Channel Frequency (MHz)
UNII 1 (5180 – 5250)	36	5180
	38	5190
	40	5200
	42	5210
	44	5220
	46	5230
	48	5240
UNII 2A (5250-5350)	52	5260
	54	5270
	56	5280
	58	5290
	60	5300
	62	5310
	64	5320
UNII 2C (5470-5725)	100	5500
	104	5520
	108	5540
	112	5560
	116	5580
	120	5600
	124	5620
	128	5640
	132	5660
	136	5680
	140	5700
	144	5720
UNII-3 (5725MHz-5850MHz)	149	5745
	151	5755
	153	5765
	155	5775
	157	5785
	159	5795
	161	5805
165	5825	

Table 5: List of Wi-Fi center Frequencies

Channel used for Wi-Fi Testing

Channel Bandwidth (20MHz)	Channel Bandwidth (40MHz)	Channel Bandwidth (80MHz)
5180	5190	5210
5240	5230	5290
5260	5270	5775
5320	5310	-
5500	5755	-
5700	5795	-
5745	-	-
5825	-	-

Note: Frequency Band 5600-5650MHz is not permitted in Canada(IC).

4.7 TUV Sample Identification number

TUV Sample Identification number : A001073243-002 -Radiated & SAR test Sample
A001073243-001 – Conducted test Sample

4.8 Report Reference

Note: Product SD820 Nano SOM- Wifi Module has multiple protocols. All the supported wireless protocols and their respective test results are issued in separate test reports, following table lists the report numbers.

Radio Protocol	Report Number
RF test report for Wi-Fi (2.4GHz) & BLE (2.4GHz)	ULR-TC568820300000037F
RF test report for BT (2.4GHz)	ULR-TC568820300000038F
RF test report for Wi-Fi (5GHz) – (This report)	ULR-TC568820300000039F
SAR test report for Wi-Fi (2.4 & 5GHz)	ULR-TC568820300000040F

5 Operational Description

Based on a complete "System on Module" architecture, the 820 Nano SOM consists of ®™ the 64-bit quad-core Qualcomm Kryo CPU, 2.2GHz capable of 4K Encode/Decode, 3/4GB LPDDR4, 32/64GB UFS and with major interfaces available via inter-board connectors. Application Development on the 820 Nano SOM is enabled with Android and Embedded Linux through a feature-rich carrier board that enables prototyping in record time. Optional Adaptor boards like LCD, Camera, Sensors and Battery Charger are also available for increased scope of development around the 820 Nano SOM.

6 Block Diagram

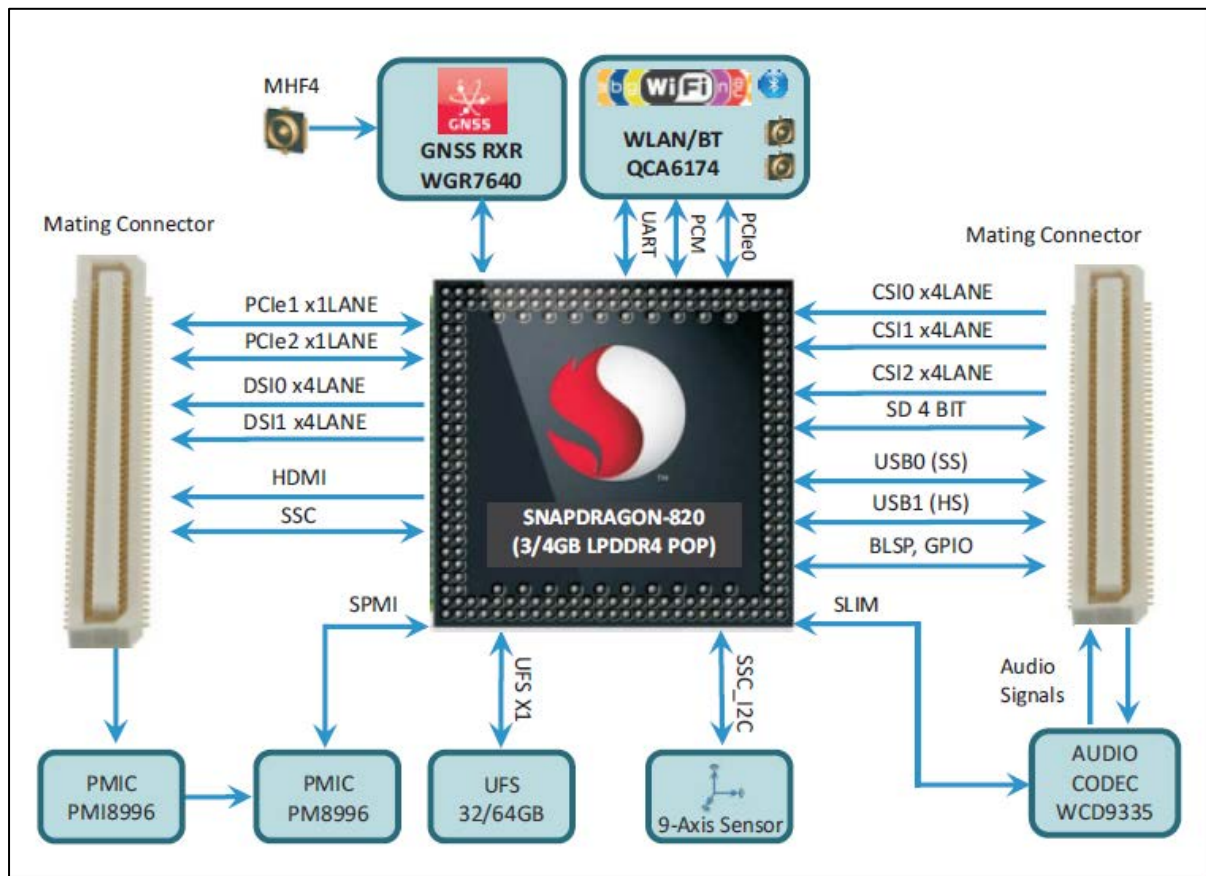

7 TEST METHODOLOGY

7.1 Radiated Emission Test

The radiated emission measurement was performed according to the procedures in ANSI C63.10-2013. The equipment under test (EUT) was placed at the middle of the 80 cm high turntable for below 1 GHz & 1.5 m height for above 1 GHz measurement, and the EUT is 3 meters far from the measuring antenna. The turntable was rotated 360° for obtaining the maximum emission. The height of the measuring antennas was scanned between 1 m and 4 m, and the antenna rotated to repeat the measurements for both the horizontal and vertical antenna polarizations. Repeat the measurement steps until the maximum emissions were obtained. The measurement above 1000 MHz was performed by horn antenna, The measurement below 30 MHz was performed by loop antenna, Measurement from 30 MHz to 200 MHz was performed by Baloon and Biconical Antenna, and measurement from 200 MHz to 1 GHz was performed by Log-Periodic Antenna.

The EUT was rotated around the X-, Y-, and Z-Axis and the results from worst case axis are recorded

7.1.1 Test Setup Configuration

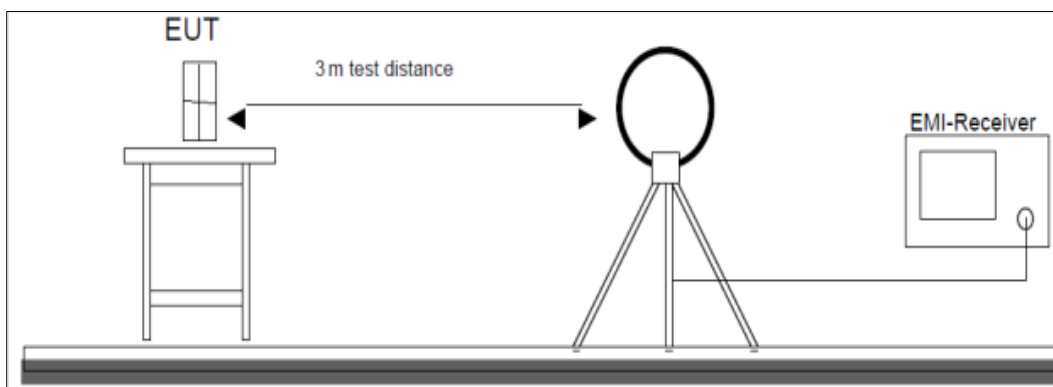

Figure 1: Frequency Range 9 kHz- 30 MHz

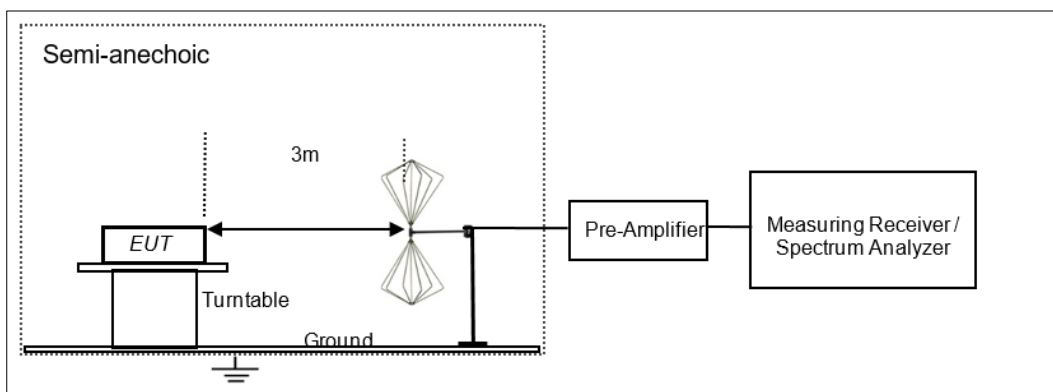

Figure 2: Frequency Range 30 MHz – 200 MHz

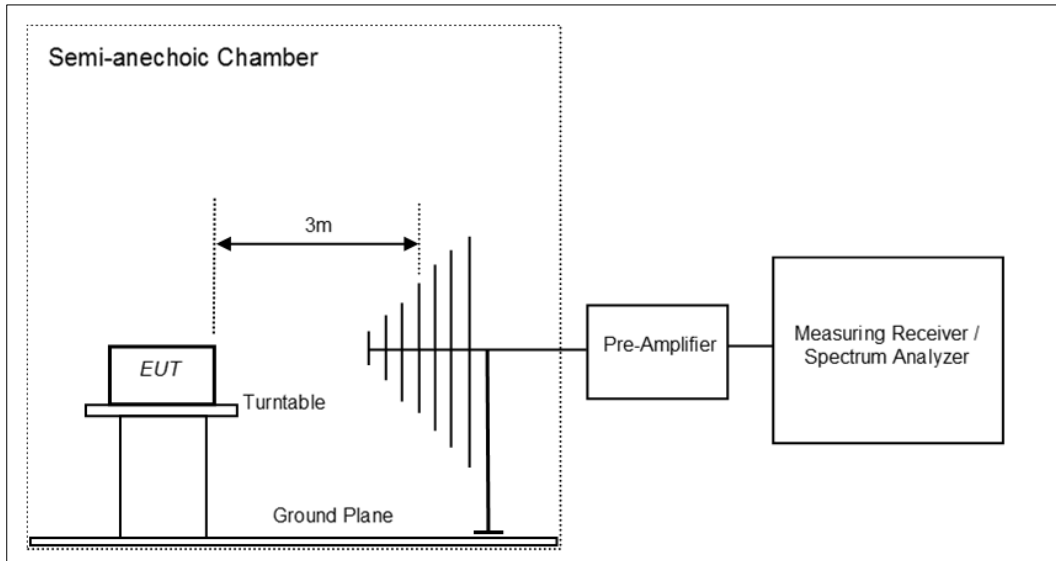

Figure 3: Frequency Range 200 MHz - 1GHz

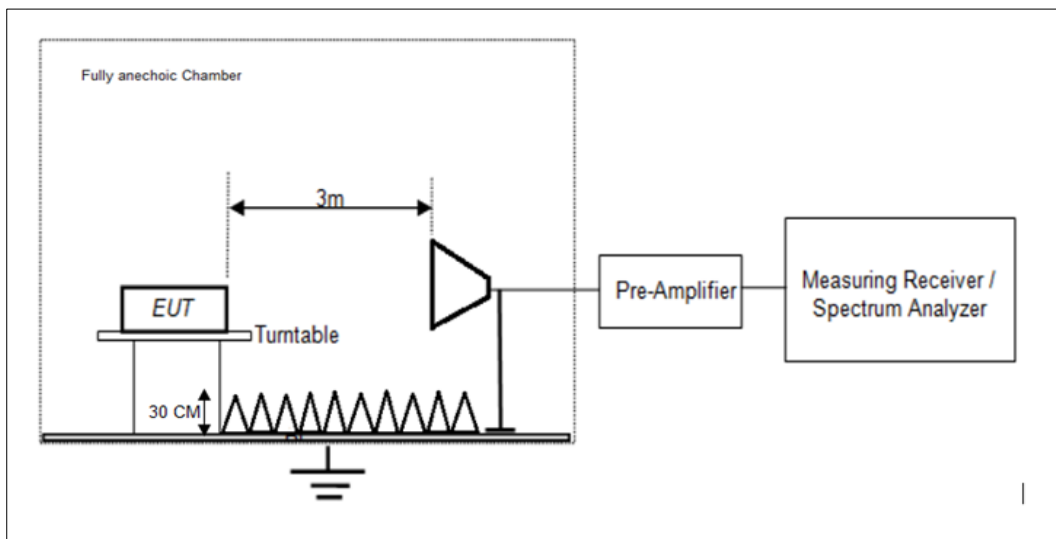

Figure 4: Frequency Range above 1 GHz

8 TEST RESULTS FOR Wi-Fi-5GHz

8.1 Spurious Radiated Emissions & Restricted Bands of Operation

Result

Pass

Test Specification	FCC part 15 Subpart E Section 15.407 (b) (15.205 & 15.209) / RSS 247 Issue 2 Section 6.2.1.2, Section 6.2.2.2, Section 6.2.3.2 & Section 6.2.4.2 / RSS Gen Issue 5 Section 8.9 & Section 8.10
Test Method	ANSI C 63.10 – 2013
Measurement Bandwidth	100kHz for below 1GHz 1MHz for above 1GHz
Measurement Location	Semi Anechoic Chamber 30MHz - 1 GHz Fully Anechoic Chamber 1 GHz - 40GHz
Measuring Distance	3 m
Detector	Refer Remark
Requirement	As per the limits mentioned in the below table
Test setup	Refer TEST METHODOLOGY

Limit:

Table 6: Undesirable emission limits

Frequency Band	Limit
5.15-5.25 GHz	e.i.r.p. -27dBm [68.2 dBuV/3m]
5.25-5.35 GHz	e.i.r.p. -27dBm [68.2 dBuV/3m]
5.47-5.725 GHz	e.i.r.p. -27dBm [68.2 dBuV/3m]
5.725-5.85 GHz	5.715 GHz to 5.725 GHz - e.i.r.p. -17dBm [78.2 dBuV/3m] 5.85 GHz to 5.86 GHz - e.i.r.p. -17dBm [78.2 dBuV/3m] other frequency range - e.i.r.p. -27dBm [68.2 dBuV/3m]

Table 7: Transmitter limits for Radiated emission

Frequency (MHz)	Field strength (μV/m)	Field strength (dBμV/m)	Distance of Measurement (m)
0.009 – 0.490	2400/F(kHz)	48.50 – 13.80	300*
0.490 – 1.705	24000/F(kHz)	33.80 – 23.00	30*
1.705 -30	30	29.54	30*
30-88	100	40.0	3
88-216	150	43.5	3
216-960	200	46.0	3
Above 960	500	54.0	3

Remark: * The limit shows in the table above of frequency range 0.009 – 0.490, 0.490 – 1.705 MHz and 1.705-30MHz is at 300 meter, 30 meter and 30 meter range respectively, which corresponds to 128.51 – 93.80, 73.80 – 62.96 and 69.54 dBμV/m at 3m range by extrapolation calculation and the measurement of loop antenna.

The emission limits shown in the above table are based on measurements employing a CISPR quasi-peak detector except for the frequency bands 9–90 kHz, 110–490 kHz and above 1000 MHz Radiated emission limits in these three bands are based on measurements employing an average detector.

Test Conditions:

Temperature (Norm) = + 23.5 °C

Voltage = 4.2VDC input

Relative humidity = 62 %

Test results:

Note: All the losses are included during measurement and final values are mentioned in the test report. Refer TEST METHODOLOGY for more details

Test results for Frequency range : 9kHz – 30MHz

No Emissions found in the frequency range 9kHz – 30MHz

Test results for Frequency range : 30MHz – 200MHz

Antenna Polarization	Frequency (MHz)	Peak (dBµV/m)	Limit (dBµV/m)	Margin (dB)
Vertical	35.28	17.39	40.00	-22.61
	44.57	18.51	40.00	-21.49
	93.38	20.02	43.50	-23.48
	184.94	25.75	43.50	-17.75
Horizontal	32.12	11.24	40.00	-28.76
	37.65	10.93	40.00	-29.07
	92.53	22.08	43.50	-21.42
	186.88	28.54	43.50	-14.96

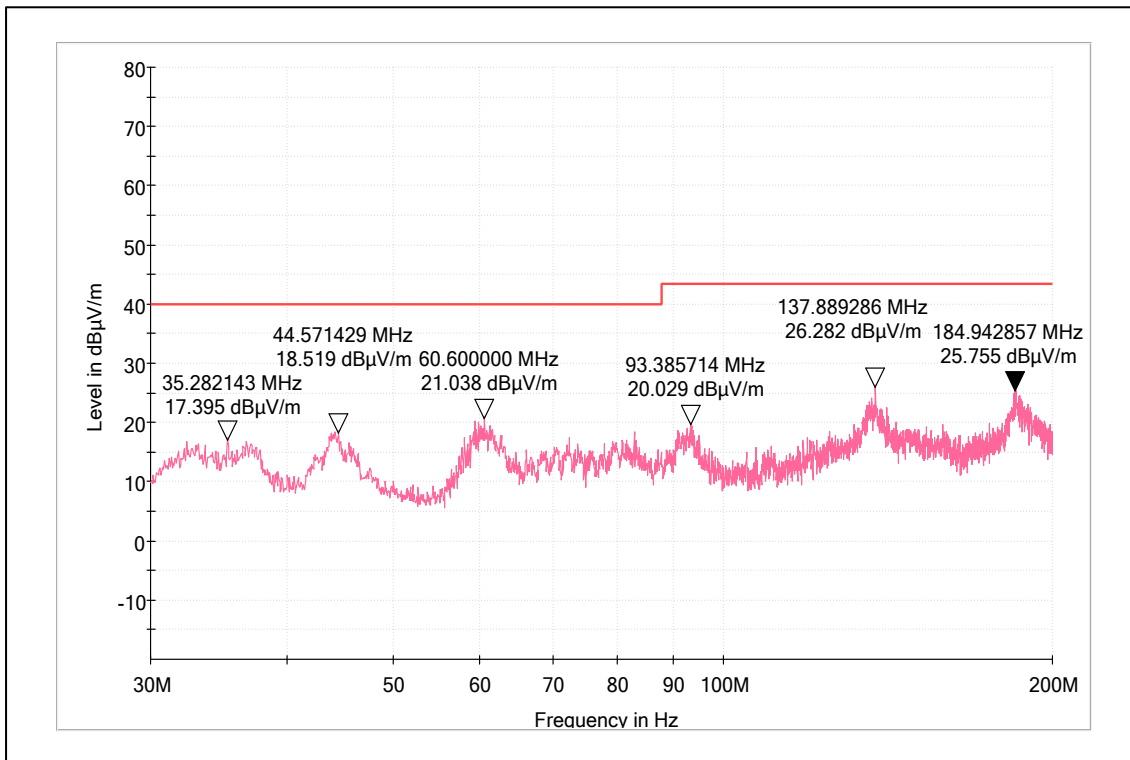

Polarization: Vertical

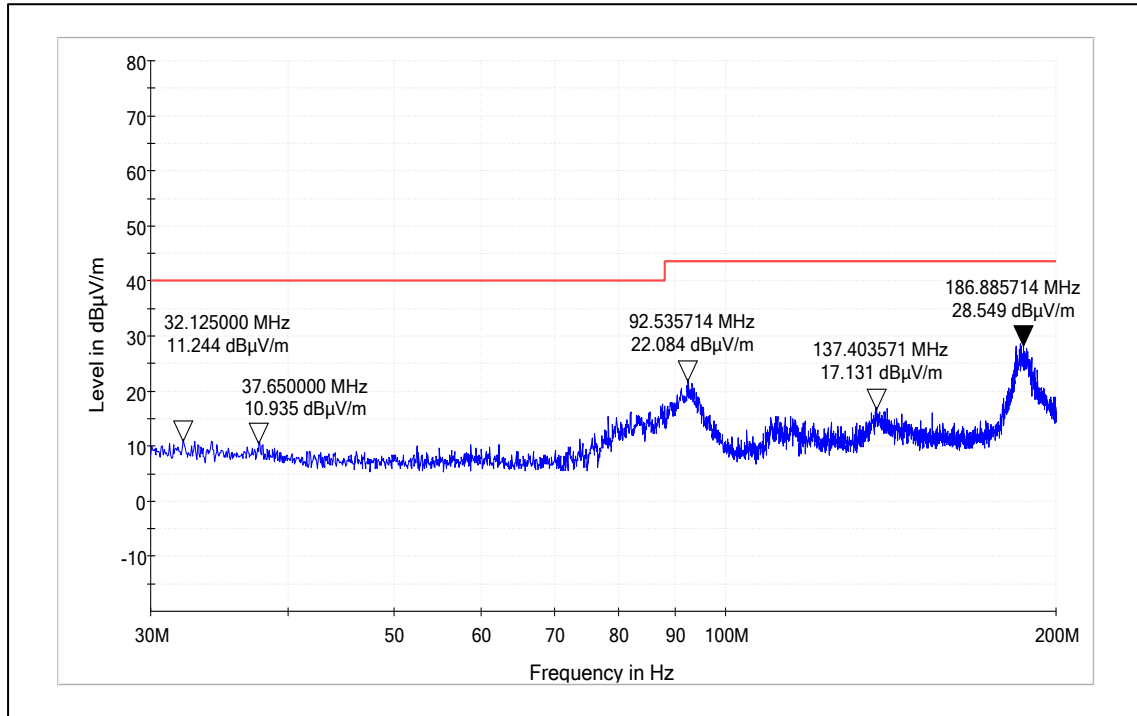

Polarization: Horizontal

Test results for frequency range 200MHz – 1GHz

Antenna Polarization	Frequency (MHz)	Peak (dBµV/m)	Limit (dBµV/m)	Margin (dB)
Vertical	235.80	32.53	46.00	-13.47
	272.63	28.69	46.00	-17.31
	567.12	22.05	46.00	-23.95
	839.76	31.73	46.00	-14.27
Horizontal	233.29	26.81	46.00	-19.19
	384.01	25.70	46.00	-20.3
	623.67	23.50	46.00	-22.5
	832.50	25.73	46.00	-20.27

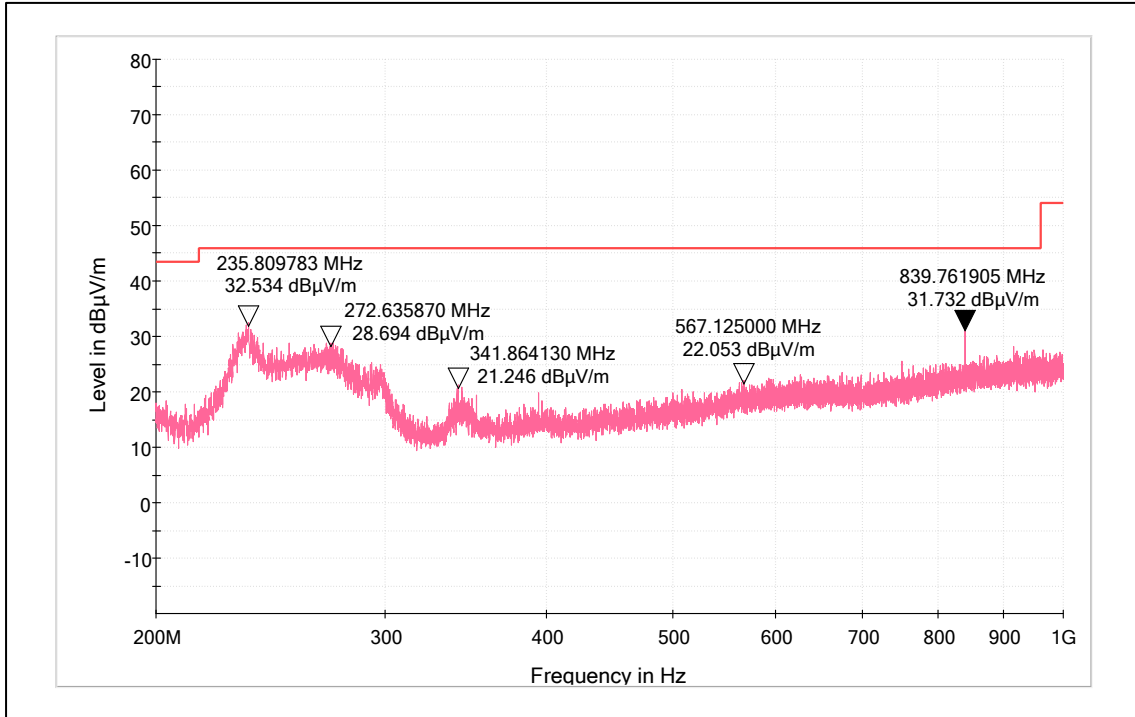

Polarization: Vertical

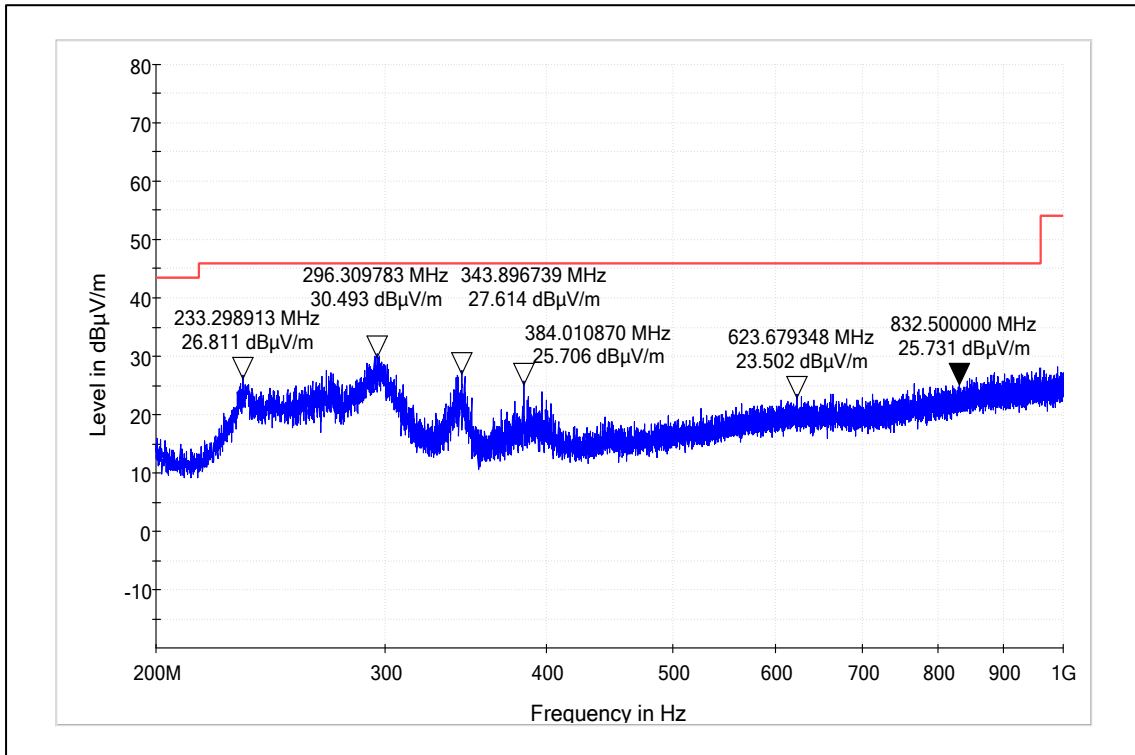

Polarization: Horizontal

Test results for frequency range – 1GHz to 40 GHz

Modulation: 802.11a
Data rate: 6Mbps

Frequency Band	Channel Frequency (MHz)	Frequency (MHz)	Polarization	Emission (dBµV/m)	Limit (dBµV/m)	Margin (dB)
UNII-1	5180	5180 (Pk)	Vertical	105.60	-	-
		5180 (Av)		94.81	-	-
		5150 (Pk)		61.72	74*	-12.28
		5150 (Av)		49.04	54*	-4.96
		10360 (Pk)		53.00	68.23	-15.23
		10360 (Av)		40.80	54	-13.20
		15540 (Pk)		54.73	68.23	-13.50
		15540 (Av)	42.58	54	-11.42	
		5180 (Pk)	Horizontal	106.98	-	-
		5180 (Av)		96.17	-	-
		5150 (Pk)		61.07	74*	-12.93
		5150 (Av)		49.04	54*	-4.96
		10360 (Pk)		52.06	68.23	-16.17
		10360 (Av)		40.67	54	-13.33
	15540 (Pk)	55.22		68.23	-13.01	
	15540 (Av)	42.55	54	-11.45		
	5240	Vertical	5240 (Pk)	109.66	-	-
			5240 (Av)	97.88	-	-
			5350 (Pk)	51.02	74*	-22.98
			5350 (Av)	38.47	54*	-15.53
			10480 (Pk)	53.76	68.23	-14.47
			10480 (Av)	41.83	54	-12.17
			15720 (Pk)	54.45	68.23	-13.78
		15720 (Av)	42.39	54	-11.61	
		Horizontal	5240 (Pk)	102.38	-	-
			5240 (Av)	91.27	-	-
			5350 (Pk)	46.44	74*	-27.56
			5350 (Av)	34.52	54*	-19.48
10480 (Pk)			53.86	68.23	-14.37	
10480 (Av)			41.11	54	-12.89	
15720 (Pk)	54.31		68.23	-13.92		
15720 (Av)	42.38	54	-11.62			
UNII-2a	5260	5260 (Pk)	Vertical	105.78	-	-
		5260 (Av)		93.65	-	-
		5350 (Pk)		50.13	74*	-23.87
		5350 (Av)		38.59	54*	-15.41
		10520 (Pk)		53.55	68.23	-14.68
		10520 (Av)		41.69	54	-12.31
		15780 (Pk)		54.57	68.23	-13.66
		15780 (Av)		42.54	54	-11.46

Frequency Band	Channel Frequency (MHz)	Frequency (MHz)	Polarization	Emission (dBµV/m)	Limit (dBµV/m)	Margin (dB)	
UNII-2a	5260	5260 (Pk)	Horizontal	101.76	-	-	
		5260 (Av)		90.01	-	-	
		5350 (Pk)		46.62	74*	-27.38	
		5350 (Av)		34.65	54*	-19.35	
		10520 (Pk)		53.22	68.23	-15.01	
		10520 (Av)		41.19	54	-12.81	
		15780 (Pk)		55.13	68.23	-13.10	
		15780 (Av)		42.58	54	-11.42	
	5320	Vertical	5320 (Pk)	105.55	-	-	
			5320 (Av)	93.47	-	-	
			5350 (Pk)	58.13	74*	-15.87	
			5350 (Av)	43.22	54*	-10.78	
			10640 (Pk)	53.93	68.23	-14.30	
			10640 (Av)	41.90	54	-12.10	
			15960 (Pk)	55.48	68.23	-12.75	
			15960 (Av)	43.19	54	-10.81	
		Horizontal	5320 (Pk)	106.09	-	-	
			5320 (Av)	94.12	-	-	
			5350 (Pk)	55.98	74*	-18.02	
			5350 (Av)	41.55	54*	-12.45	
			10640 (Pk)	54.08	68.23	-14.15	
			10640 (Av)	41.85	54	-12.15	
			15960 (Pk)	55.30	68.23	-12.93	
			15960 (Av)	43.18	54	-10.82	
	UNII-2c	5500	5500 (Pk)	Vertical	104.16	-	-
			5500 (Av)		92.74	-	-
			5460 (Pk)		60.04	74*	-13.96
			5460 (Av)		48.49	54*	-5.51
11000 (Pk)			55.04		68.23	-13.19	
11000 (Av)			42.67		54	-11.33	
16500 (Pk)			56.19		68.23	-12.04	
16500 (Av)			43.93		54	-10.07	
Horizontal		5500 (Pk)	106.45	-	-		
		5500 (Av)	94.55	-	-		
		5460 (Pk)	60.62	74*	-13.38		
		5460 (Av)	48.66	54*	-5.34		
		11000 (Pk)	54.82	68.23	-13.41		
		11000 (Av)	42.63	54	-11.37		
		16500 (Pk)	55.67	68.23	-12.56		
		16500 (Av)	43.92	54	-10.08		

Frequency Band	Channel Frequency (MHz)	Frequency (MHz)	Polarization	Emission (dBµV/m)	Limit (dBµV/m)	Margin (dB)		
	5700	5700 (Pk)	Vertical	105.56	-	-		
		5700 (Av)		94.14	-	-		
		5460 (Pk)		44.06	74*	-29.94		
		5460 (Av)		30.79	54*	-23.21		
		11400 (Pk)		56.14	68.23	-12.09		
		11400 (Av)		44.44	54	-9.56		
		17100 (Pk)		57.80	68.23	-10.43		
		17100 (Av)		45.80	54	-8.20		
		5700 (Pk)		105.39	-	-		
		5700 (Av)	93.70	-	-			
		5460 (Pk)	43.52	74*	-30.48			
		5460 (Av)	30.84	54*	-23.16			
		11400 (Pk)	55.46	68.23	-12.77			
		11400 (Av)	43.41	54	-10.59			
		17100 (Pk)	58.66	68.23	-9.57			
		17100 (Av)	45.79	54	-8.21			
		UNII-3	5745	5745 (Pk)	Vertical	102.99	-	-
				5745 (Av)		92.73	-	-
11490 (Pk)	58.98			68.23		-9.25		
11490 (Av)	46.00			54		-8.00		
17235 (Pk)	59.54			68.23		-8.69		
17235 (Av)	46.85			54		-7.15		
5745 (Pk)	104.72			-	-			
5745 (Av)	93.46			-	-			
11490 (Pk)	56.49			68.23	-11.74			
11490 (Av)	43.94			54	-10.06			
17235 (Pk)	59.26			68.23	-8.97			
17235 (Av)	46.87			54	-7.13			
5825	Vertical		5825 (Pk)	104.94	-	-		
			5825 (Av)	93.53	-	-		
			11650 (Pk)	58.85	68.23	-9.38		
			11650 (Av)	46.04	54	-7.96		
			17475 (Pk)	53.84	68.23	-14.39		
			17475 (Av)	41.78	54	-12.22		
	Horizontal		5825 (Pk)	100.33	-	-		
			5825 (Av)	88.13	-	-		
			11650 (Pk)	55.70	68.23	-12.53		
			11650 (Av)	43.88	54	-10.12		
			17475 (Pk)	61.17	68.23	-7.06		
			17475 (Av)	48.34	54	-5.66		

Note:

* : Indicate restricted band of operation §15.205

Pk: Peak Detector; Av: Average Detector

Worst case emissions for restricted band of operation

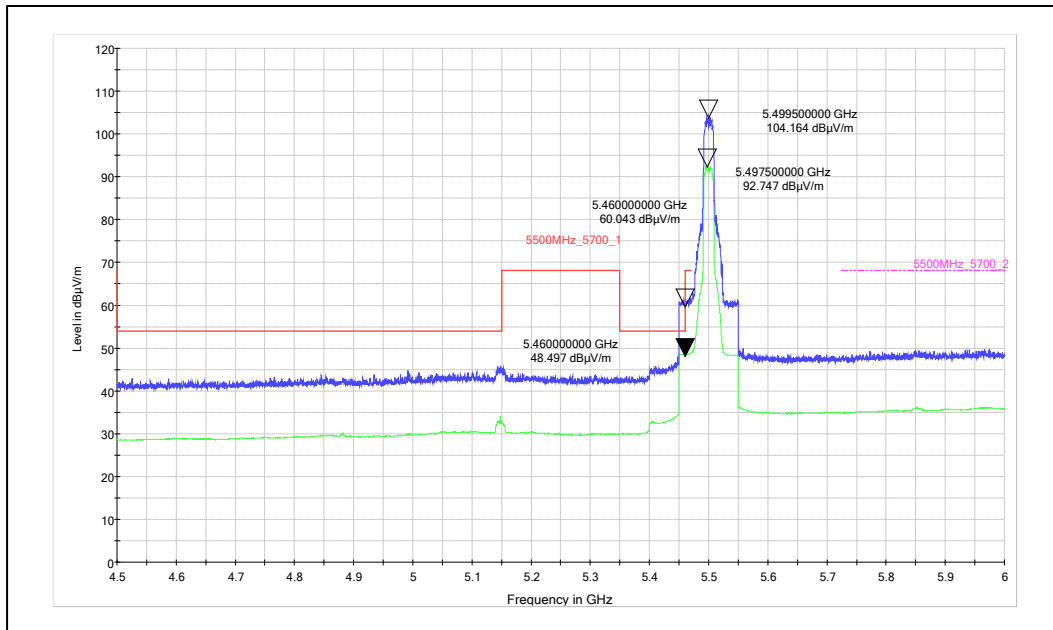

Channel Frequency: 5500MHz

Polarization: Vertical

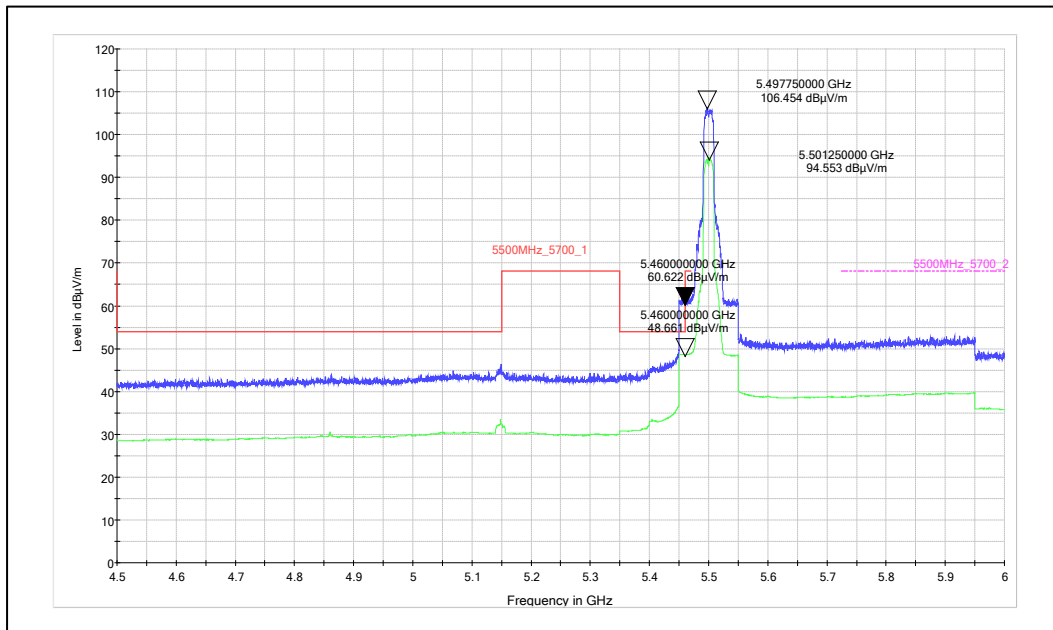

Channel Frequency: 5500MHz

Polarization: Horizontal

Worst case emissions for Spurious radiated emissions above 1GHz

Data rate: 6Mbps
Channel Frequency: 5500MHz

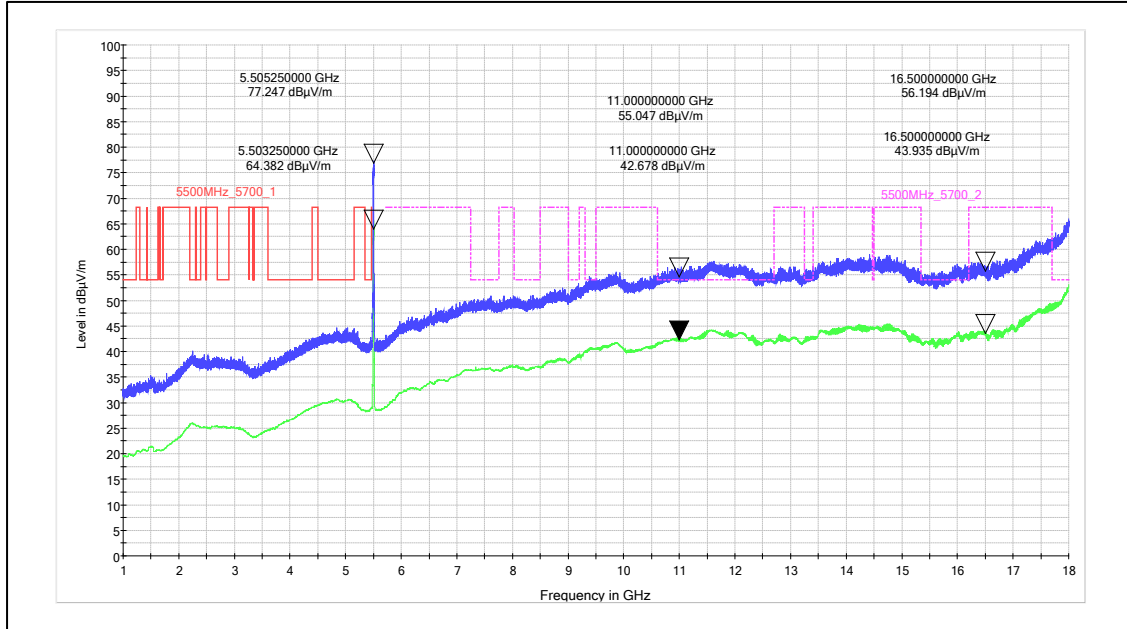

Frequency Range: 1GHz to 18GHz

Polarization: Vertical

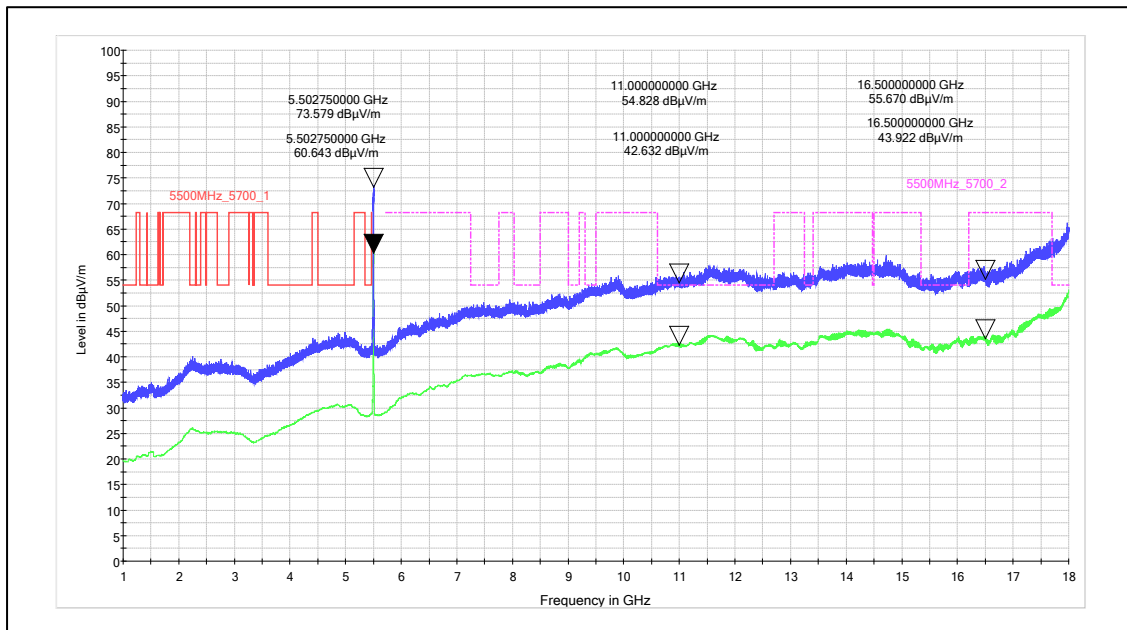

Frequency Range: 1GHz to 18GHz

Polarization: Horizontal

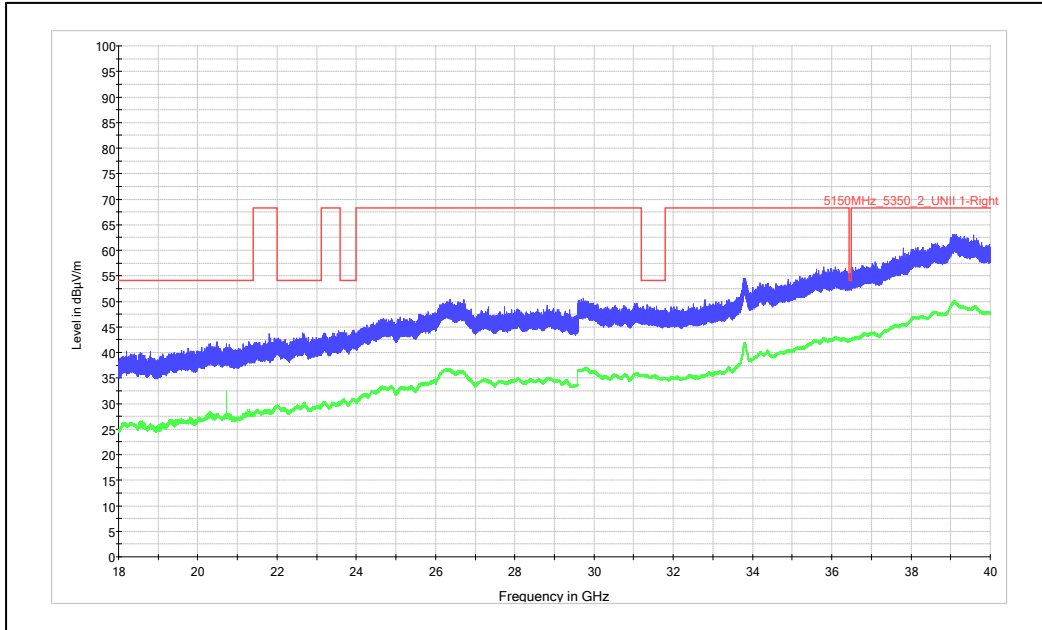

Frequency Range: 18GHz to 40GHz

Polarization: Vertical

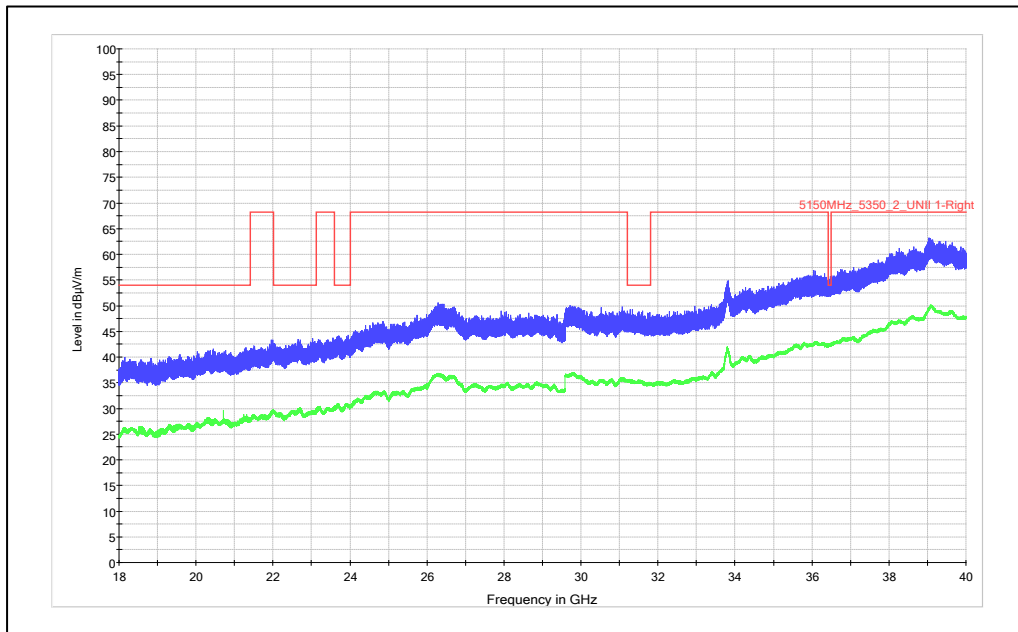

Frequency Range: 18GHz to 40GHz

Polarization: Horizontal

Prüfbericht - Nr.:
Test Report No.:

ULR-TC568820300000039F

Seite 27 von 43
Page 27 of 43

Modulation: 802.11ac-20MHz
Data rate: MCS0

Frequency Band	Channel Frequency (MHz)	Frequency (MHz)	Polarization	Emission (dBµV/m)	Limit (dBµV/m)	Margin (dB)
UNII-1	5180	5180 (Pk)	Vertical	105.91	-	-
		5180 (Av)		94.00	-	-
		5150 (Pk)		61.67	74*	-12.33
		5150 (Av)		48.96	54*	-5.04
		10360 (Pk)		53.70	68.23	-14.53
		10360 (Av)		40.85	54	-13.15
		15540 (Pk)		55.57	68.23	-12.66
		15540 (Av)		42.73	54	-11.27
		5180 (Pk)	Horizontal	102.47	-	-
		5180 (Av)		90.92	-	-
		5150 (Pk)		56.04	74*	-17.96
		5150 (Av)		44.12	54*	-9.88
		10360 (Pk)		53.27	68.23	-14.96
		10360 (Av)		40.88	54	-13.12
		15540 (Pk)		55.52	68.23	-12.71
		15540 (Av)		42.77	54	-11.23
	5240	Vertical	5240 (Pk)	106.14	-	-
			5240 (Av)	94.19	-	-
			5350 (Pk)	45.75	74*	-28.25
			5350 (Av)	33.92	54*	-20.08
			10480 (Pk)	52.79	68.23	-15.44
			10480 (Av)	41.56	54	-12.44
			15720 (Pk)	54.06	68.23	-14.17
			15720 (Av)	42.39	54	-11.61
		Horizontal	5240 (Pk)	100.86	-	-
			5240 (Av)	89.01	-	-
			5350 (Pk)	44.99	74*	-29.01
			5350 (Av)	31.64	54*	-22.36
10480 (Pk)			53.42	68.23	-14.81	
10480 (Av)			41.19	54	-12.81	
15720 (Pk)			54.24	68.23	-13.99	
15720 (Av)			42.42	54	-11.58	
UNII-2a	5260	Vertical	5260 (Pk)	105.07	-	-
			5260 (Av)	93.22	-	-
			5350 (Pk)	50.44	74*	-23.56
			5350 (Av)	38.53	54*	-15.47
			10520 (Pk)	53.72	68.23	-14.51
			10520 (Av)	41.27	54	-12.73
			15780 (Pk)	55.92	68.23	-12.31
			15780 (Av)	42.62	54	-11.38

Frequency Band	Channel Frequency (MHz)	Frequency (MHz)	Polarization	Emission (dBµV/m)	Limit (dBµV/m)	Margin (dB)	
UNII-2a		5260 (Pk)	Horizontal	100.66	-	-	
		5260 (Av)		88.94	-	-	
		5350 (Pk)		46.90	74*	-27.10	
		5350 (Av)		34.62	54*	-19.38	
		10520 (Pk)		53.16	68.23	-15.07	
		10520 (Av)		41.27	54	-12.73	
		15780 (Pk)		55.08	68.23	-13.15	
		15780 (Av)		42.64	54	-11.36	
	5320	Vertical	5320 (Pk)	106.72	-	-	
			5320 (Av)	94.87	-	-	
			5350 (Pk)	58.79	74*	-15.21	
			5350 (Av)	45.31	54*	-8.69	
			10640 (Pk)	53.86	68.23	-14.37	
			10640 (Av)	41.87	54	-12.13	
			15960 (Pk)	56.04	68.23	-12.19	
			15960 (Av)	43.31	54	-10.69	
		Horizontal	5320 (Pk)	100.34	-	-	
			5320 (Av)	88.99	-	-	
			5350 (Pk)	52.61	74*	-21.39	
			5350 (Av)	38.82	54*	-15.18	
			10640 (Pk)	54.22	68.23	-14.01	
			10640 (Av)	41.90	54	-12.10	
			15960 (Pk)	55.51	68.23	-12.72	
			15960 (Av)	43.29	54	-10.71	
	UNII-2c	5500	Vertical	5500 (Pk)	107.52	-	-
				5500 (Av)	96.61	-	-
				5460 (Pk)	65.10	74*	-8.90
				5460 (Av)	53.49	54*	-0.51
11000 (Pk)				55.18	68.23	-13.05	
11000 (Av)				42.70	54	-11.30	
16500 (Pk)				56.24	68.23	-11.99	
16500 (Av)				42.17	54	-11.83	
Horizontal		5500 (Pk)	99.85	-	-		
		5500 (Av)	88.14	-	-		
		5460 (Pk)	55.67	74*	-18.33		
		5460 (Av)	43.76	54*	-10.24		
		11000 (Pk)	54.31	68.23	-13.92		
		11000 (Av)	42.48	54	-11.52		
		16500 (Pk)	56.78	68.23	-11.45		
		16500 (Av)	44.12	54	-9.88		

Prüfbericht - Nr.:
Test Report No.:

ULR-TC56882030000039F

Seite 29 von 43
Page 29 of 43

Frequency Band	Channel Frequency (MHz)	Frequency (MHz)	Polarization	Emission (dBµV/m)	Limit (dBµV/m)	Margin (dB)
UNII-2c	5700	5700 (Pk)	Vertical	105.72	-	-
		5700 (Av)		94.32	-	-
		5460 (Pk)		43.90	74*	-30.10
		5460 (Av)		30.87	54*	-23.13
		11400 (Pk)		55.67	68.23	-12.56
		11400 (Av)		43.63	54	-10.37
		17100 (Pk)		57.80	68.23	-10.43
		17100 (Av)		45.94	54	-8.06
		5700 (Pk)	Horizontal	98.74	-	-
		5700 (Av)		86.69	-	-
		5460 (Pk)		43.50	74*	-30.50
		5460 (Av)		30.77	54*	-23.23
		11400 (Pk)		55.28	68.23	-12.95
		11400 (Av)		43.49	54	-10.51
		17100 (Pk)		58.00	68.23	-10.23
		17100 (Av)		45.97	54	-8.03
UNII-3	5745	5745 (Pk)	Vertical	104.90	-	-
		5745 (Av)		90.35	-	-
		11490 (Pk)		56.89	68.23	-11.34
		11490 (Av)		44.74	54	-9.26
		17235 (Pk)		59.53	68.23	-8.70
		17235 (Av)		47.01	54	-6.99
		5745 (Pk)	Horizontal	93.81	-	-
		5745 (Av)		78.94	-	-
		11490 (Pk)		55.77	68.23	-12.46
		11490 (Av)		43.28	54	-10.72
	5825	17235 (Pk)	Vertical	59.34	68.23	-8.89
		17235 (Av)		47.02	54	-6.98
		5825 (Pk)	Vertical	101.58	-	-
		5825 (Av)		86.30	-	-
		11650 (Pk)		56.61	68.23	-11.62
		11650 (Av)		44.72	54	-9.28
		17475 (Pk)		60.05	68.23	-8.18
		17475 (Av)		48.44	54	-5.56
		5825 (Pk)	Horizontal	93.33	-	-
		5825 (Av)		77.55	-	-
11650 (Pk)	55.95	68.23		-12.28		
11650 (Av)	43.93	54		-10.07		
17475 (Pk)	Horizontal	61.25	68.23	-6.98		
17475 (Av)		48.45	54	-5.55		

Note:

* : Indicate restricted band of operation §15.205
Pk: Peak Detector; Av: Average Detector

Worst case emissions for restricted band of operation

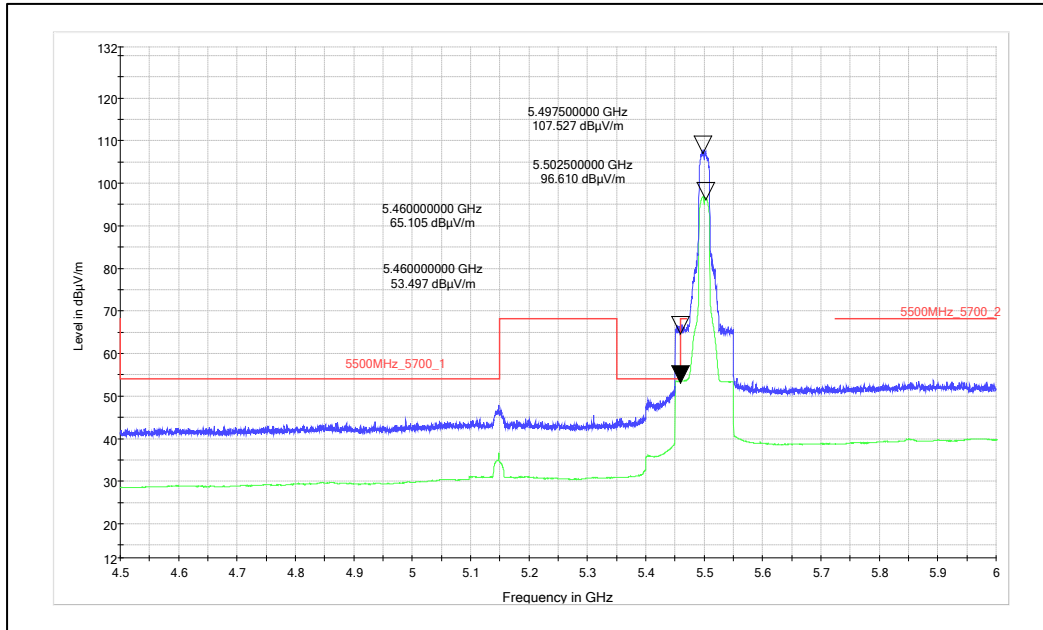

Channel Frequency: 5500MHz

Polarization: Vertical

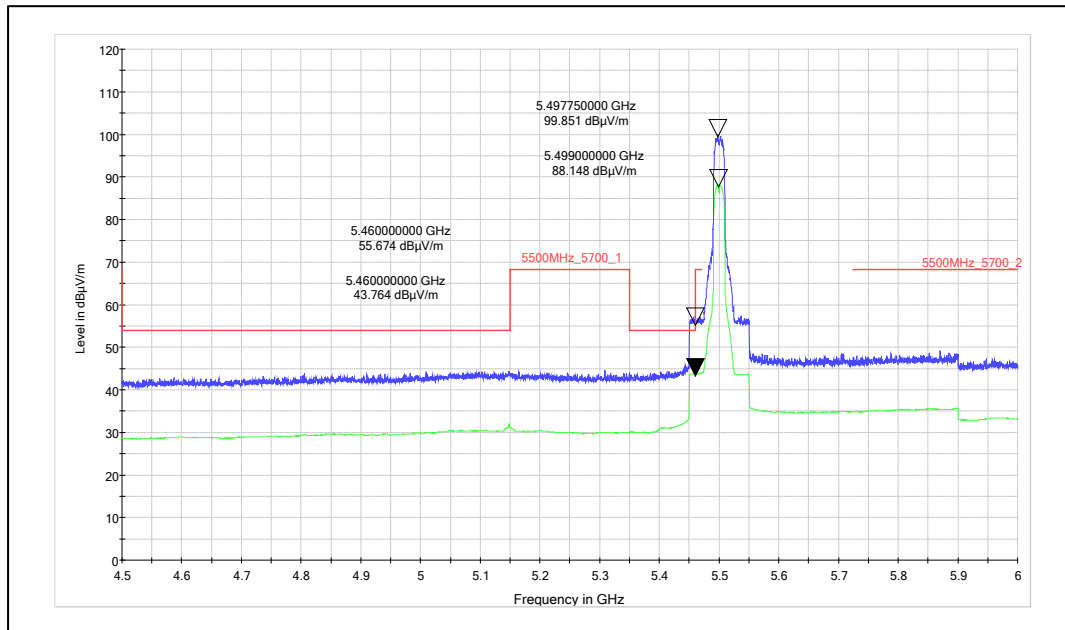

Channel Frequency: 5500MHz

Polarization: Horizontal