



2023

深圳祥博一科技有限公司

Shenzhen Xiangboyi Technology Co. Ltd

天线测试报告

Antenna report



TEST REPORT

01 客户名称/Customer：和天创

02 项目名称/Project：L007

03 立项编号/Project NO：XBY230284

04 工程师/Engineer

PART 1

测试报告版本/Report version

日期 Date	天线版本 Antenna version	主板版本 PCB version	变更描述 Description of Change
2023-8-5			样品天线测试数据

PART 2

项目信息/Project brief

NO	ITEMS	DETAILS
1	工作频段 Operating band	WIFI:2.4G/5G BT
2	频率范围 Frequency band	WIFI:2400-2500Mhz ;5150-5850Mhz BT:2400-2500Mhz
3	天线类型 Antenna type	WIFI:PIFA BT:PIFA
4	天线材质及实现形状 Material and implementation shape	FPC+焊线

PART 3

Test system and equipment

	测试项目/Test items	设备/equipment
1: S参数 S parameter	1. 回波损耗 Return loss 2. 驻波比 VSWR	网络分析仪/Network analyzer: A338/A333
2: 耦合功率测试 Active test	1. 发射功率 Transmitting power 2. 接收灵敏度 Receiving sensitivity	综合测试仪/Comprehensive test instrument: Agilent 8960/ CMW500
3: 辐射模式与增益 Radiation mode and gain	1. 效率,增益 gain 1. 辐射模式 Radiation mode	1. 暗室/Shielding room: 7x4x3 m (ETS-3D) 2. 网络分析仪/Network analyzer: HP 8753D

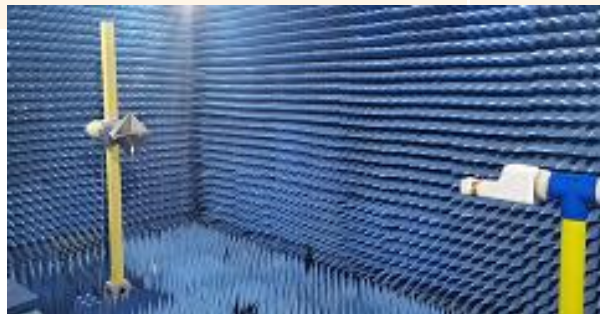
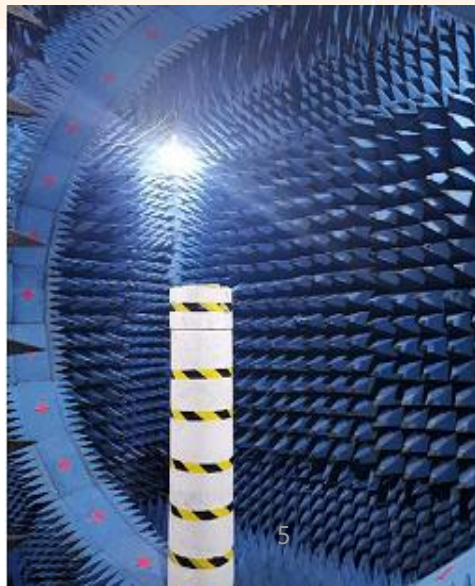

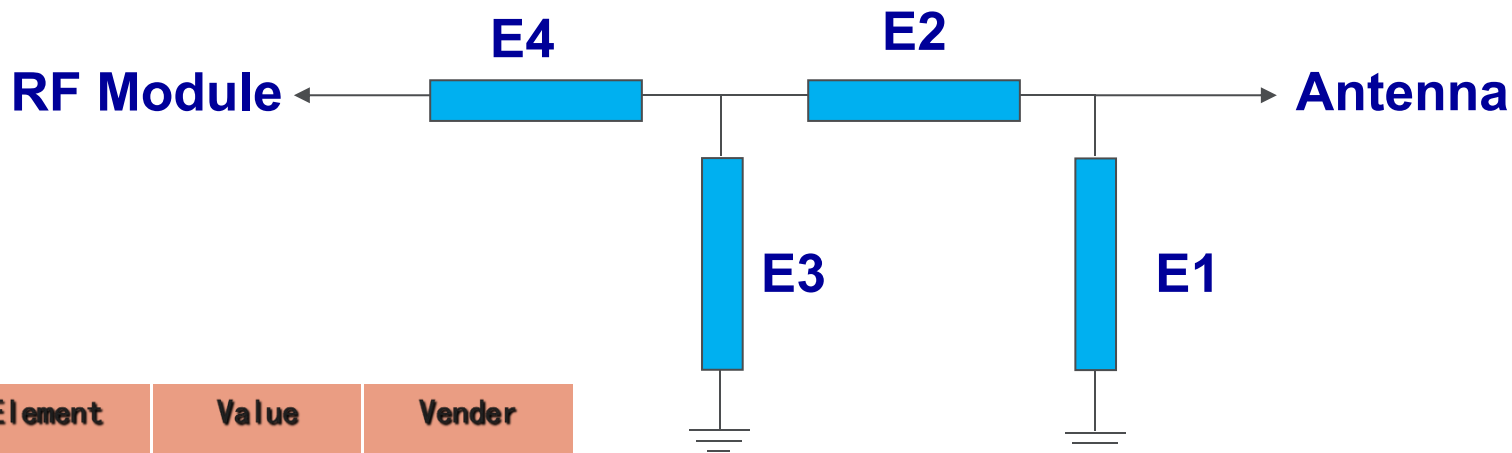

Element	Value	Vender
E1 (0402)	NA	
E2 (0402)	0 Ohm	
E3 (0402)	NA	
E4 (0402)	0 Ohm	

Original match unchanged.

WIFI BAND	802.11b : 11Mbps (2.4G)			802.11g : 54Mbps (2.4G)		
Channel	CH1	CH7	CH13	CH1	CH7	CH13
TRP	15.69	14.92	14.2	12.22	11.6	11.16
TIS			-79.82			-69.77
WIFI BAND	802.11n : MCS7 (2.4G)			802.11a : 54Mbps (5G)		
Channel	CH1	CH7	CH13	CH36	CH149	CH161
TRP	11.89	11.46	11.07	13.59	12.69	12.41
TIS			-70.34			-70.84

WIFI天线无源数据。

Freq (MHz)	Effi (%)	Gain (dBi)
2400	37.91	0.66
2450	38.84	1.58
2500	40.71	1.41
5000	46.79	2.96
5100	50.95	2.77
5200	44.52	2.33
5300	41.99	1.9
5400	47.97	2.21
5500	48.27	2.21
5600	50.14	2.62
5700	53.79	3.23
5800	51.43	3.97
5900	45.16	2.85
6000	38.26	1.35

BT天线无源数据。

Freq (MHz)	Effi (%)	Gain (dBi)
2400	38.17	0.65
2450	38.55	1.21
2500	37.57	0.85

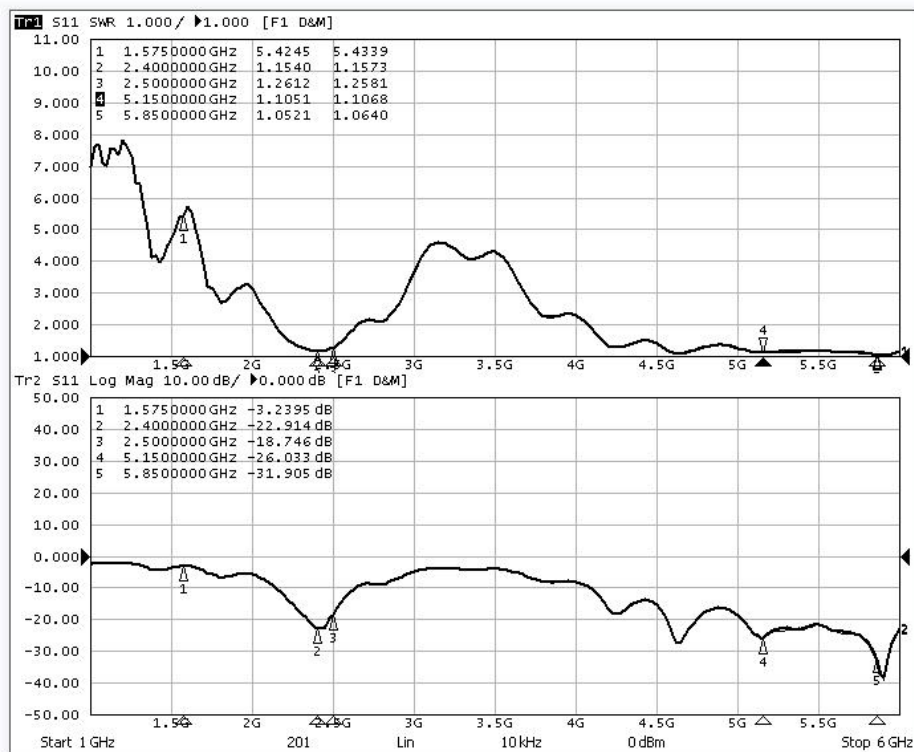

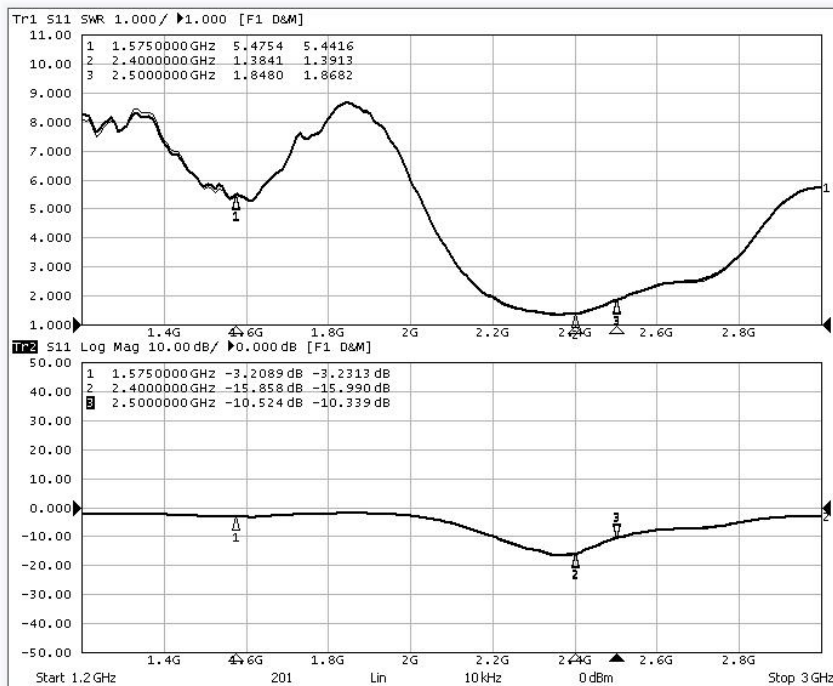

PART 6

测试数据/RFReport

WiFi天线辐射方向图。

Horizontal

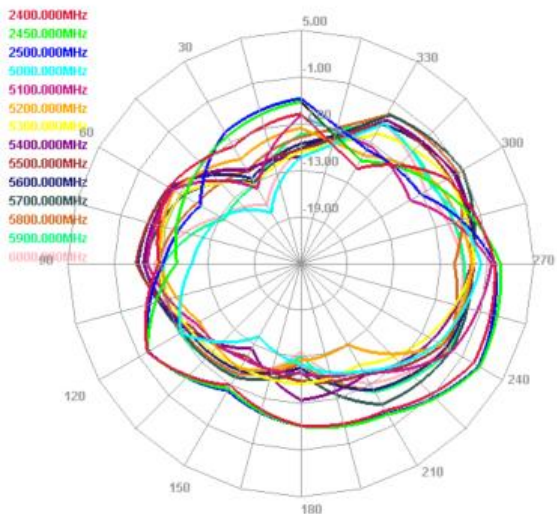

E1 Face

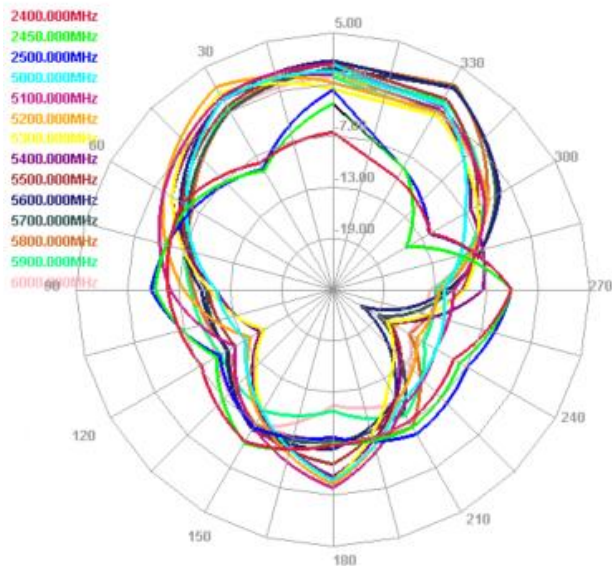

E2 Face

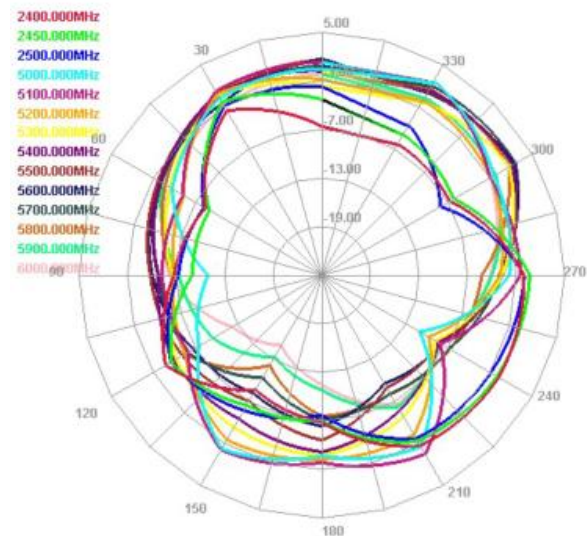

PART 6

测试数据/RF Report

BT天线辐射方向图。

Horizontal

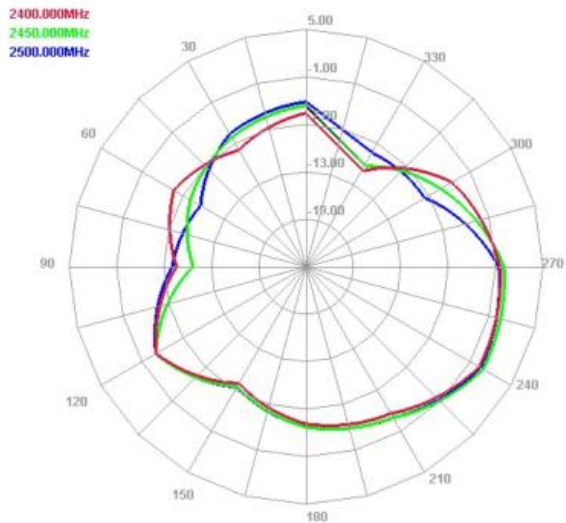

E1 Face

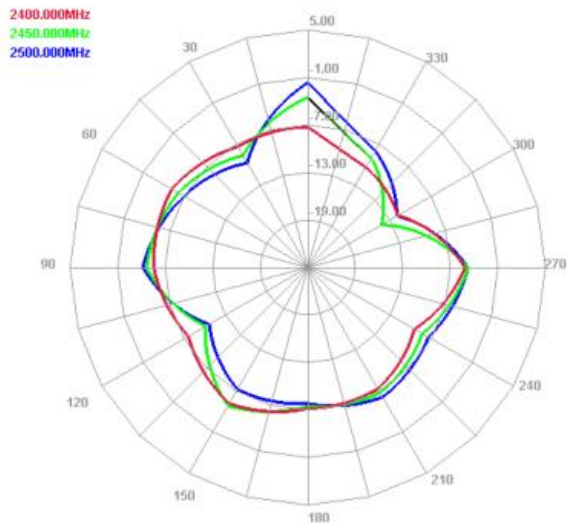

E2 Face

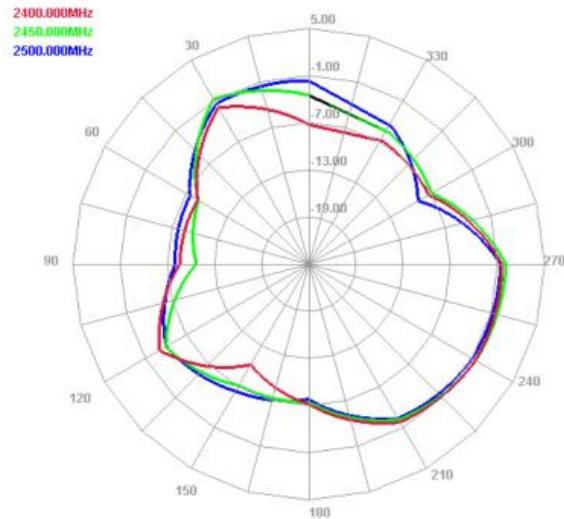

PART 7

组装方式/Assembly method

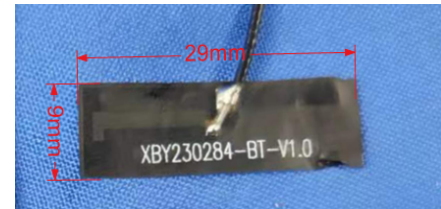
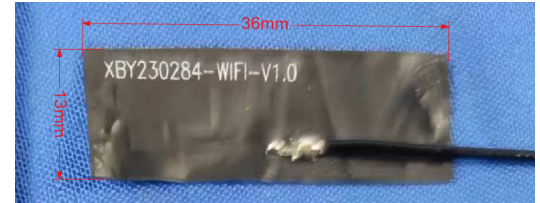
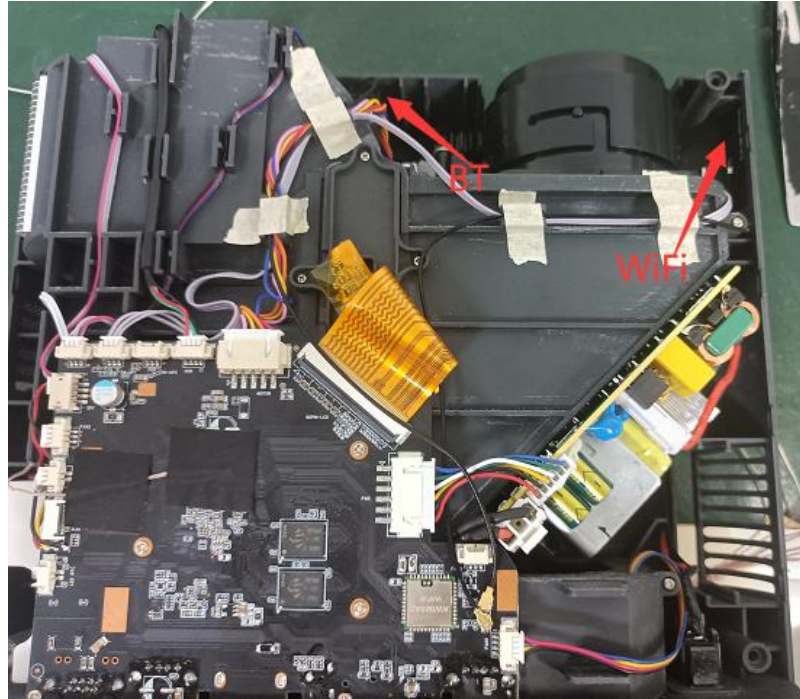





2023 Thanks!

Your content to play here, or through your copy, paste in this box, and select only the text. Your content to play here, or through your copy, paste in this box, and select only the text.