



2022

深圳祥博一科技有限公司

Shenzhen Xiangboyi Technology Co. Ltd

天线测试报告

Antenna report



TEST REPORT

01 客户名称/Customer：和天创

02 项目名称/Project：L003

03 立项编号/Project NO：XBY220449

04 工程师/Engineer：魏道发
电话/Phone：18123850014

PART 1

测试报告版本/Report version

日期 Date	天线版本 Antenna version	主板版本 PCB version	变更描述 Description of Change
2022-09-21			样品天线测试数据

NO	ITEMS	DETAILS
1	工作频段 Operating band	WIFI:2.4G; 5.8G
2	频率范围 Frequency band	WIFI: 2400-2500Mhz; 5180-5850Mhz
3	天线类型 Antenna type	MAIN:
4	天线材质及实现形状 Material and implementation shape	FPC

PART 3

Test system and equipment

	测试项目/Test items	设备/equipment
1: S参数 S parameter	1. 回波损耗 Return loss 2. 驻波比 VSWR	网络分析仪/Network analyzer: A338/A333
2: 耦合功率测试 Active test	1. 发射功率 Transmitting power 2. 接收灵敏度 Receiving sensitivity	综合测试仪/Comprehensive test instrument: Agilent 8960/ CMW500
3: 辐射模式与增益 Radiation mode and gain	1. 辐射模式 Radiation mode 2. 天线增益 Gain	1. 暗室/Shielding room: 7x4x3 m (ETS-3D) 2. 网络分析仪/Network analyzer: HP 8753D

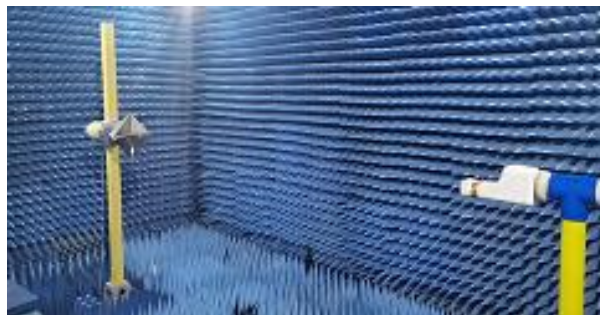
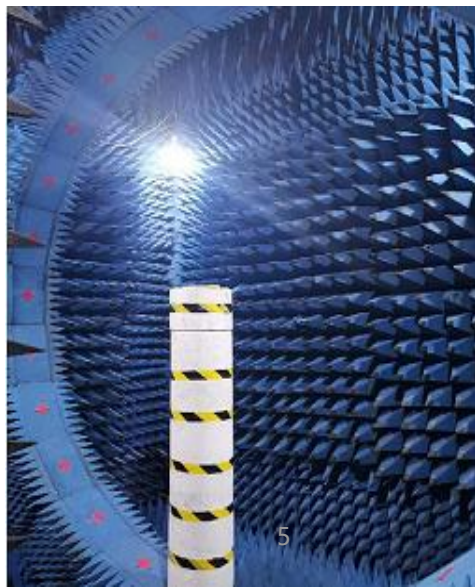

PART 4

匹配电路/Matching Circuits

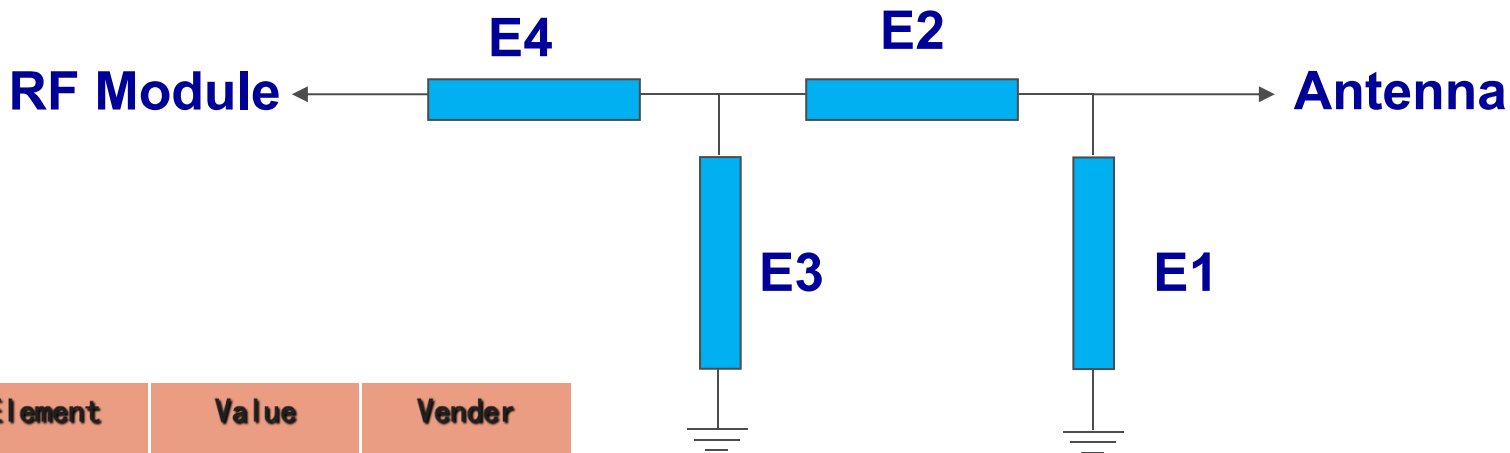

Element	Value	Vender
E1 (0402)	NA	
E2 (0402)	0 Ohm	
E3 (0402)	NA	
E4 (0402)	0 Ohm	

Original match unchanged.

PART 5

测试数据/RF Report

WIFI BAND	802.11a : 54Mbps (5G)					
Channel	CH36	CH149	CH161			
TRP	13.93	14.8	14.06			
TIS			-69.45			

WIFI BAND	802.11b : 11Mbps (2.4G)			802.11g : 54Mbps (2.4G)		
Channel	CH1	CH6	CH11	CH1	CH6	CH11
TRP	13.63	14.29	14.66	15.85	14.62	15.37
TIS			-77.19			-68.89

WIFI BAND	802.11n : MCS7 (2.4G)					
Channel	CH1	CH6	CH11			
TRP	15.9	15.07	15.33			
TIS			-69.75			

PART 6

测试数据/RF Report

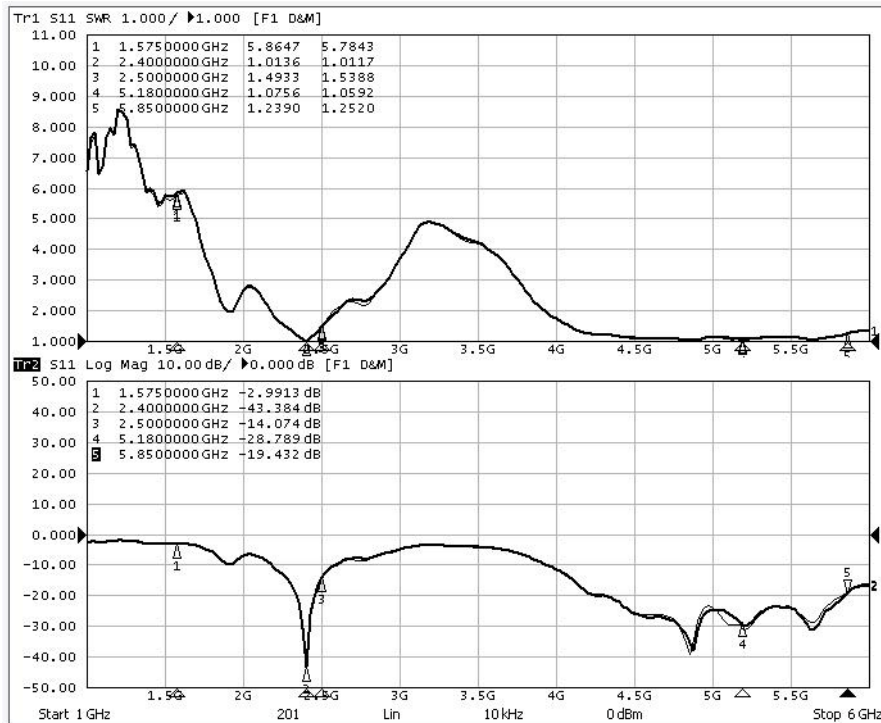

PART 6

测试数据/RF Report

Passive Test For 2.4G		
Freq (MHz)	Effi (%)	Gain (dBi)
2400	46.51	2.1
2410	41.26	1.61
2420	45.58	1.99
2430	34.19	0.13
2440	40.74	1.37
2450	33.54	0.85
2460	34.58	1.17
2470	39.98	0.7
2480	34.68	1.06
2490	36.27	0.25
2500	34.42	1.03

Passive Test For 5G		
Freq (MHz)	Effi (%)	Gain (dBi)
5000	40.73	2.07
5050	42.3	2.05
5100	36.94	1.71
5150	35.56	2.13
5200	44.77	2.23
5250	40.89	0.94
5300	36.02	1.03
5350	38.1	0.07
5400	35.81	0.32
5450	38.95	0.74
5500	36.23	1.43
5550	32.13	1.19
5600	39.81	0.37
5650	48.44	1.99
5700	36.26	1.95
5750	40.05	1.69
5800	39.95	2.53
5850	43.76	1.98
5900	38.61	1.61
5950	38.25	0.94
6000	35.46	1.27

PART 6

测试数据/RF Report

Horizontal

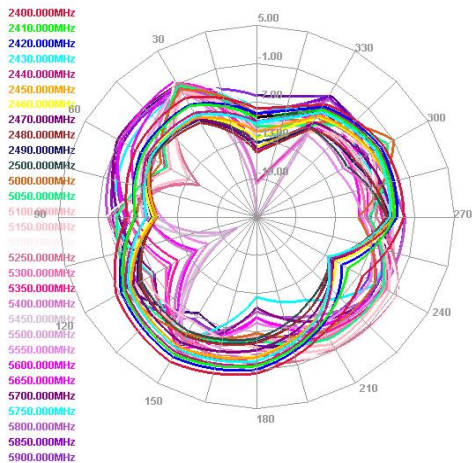

E1 Face

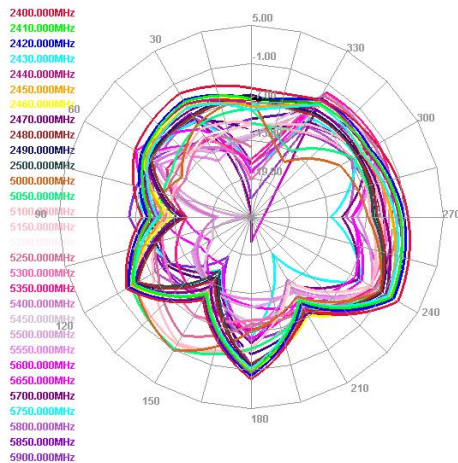

E2 Face

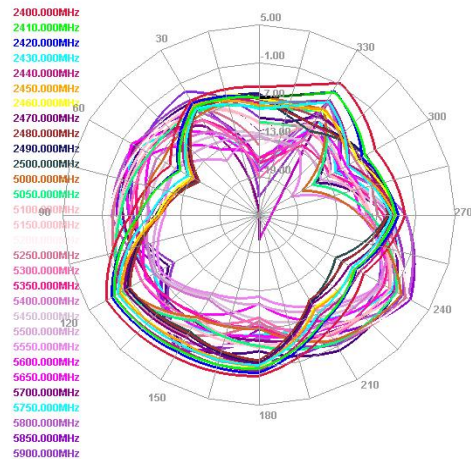

PART 7

组装方式/Assembly method



PART 8

整机图片 Picture of complete machine





2022 Thanks!

Your content to play here, or through your copy, paste in this box, and select only the text. Your content to play here, or through your copy, paste in this box, and select only the text.