

80g双胶186C+K 风琴折
 双色印刷 75x95mm 中文

正面

Model: MS22150



MUSICBOX
PORTABLE SPEAKER

Quick Start Guide
Please read this Quick Start Guide carefully and keep it for future use.

Product Overview

- Speaker Unit
- AUX IN Cable
- USB-C Charging Cable
- Quick Start Guide & Warranty Letter

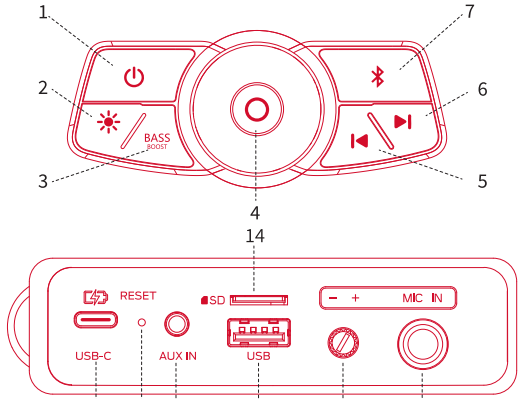

1.Power On/Off Button
Audio input selection
Charging LED Indicator
2.Lighting Effects On / Off

3.Sound mode switch

4.Multi Function Button (MFB)
Master Volume Control
Music play / pause...

5.Previous Song

6.Next Song

7.Bluetooth / LED Indicator

8.USB-C Charging Input

9.Reset Button

10.AUX IN Port

11.USB IN (Audio) Port

12.Reverb adjustment

13.MIC IN Port (6.35mm)

14.Micro SD CARD IN Port

LED Indicator Guide

Description	Voice/Tone	Status
○ White LED light	Opening Tone	Power On
● The white LED is off	Goodbye	Power Off
※ White LED lights flashing	Discovering	Not connected
○ White LED light	Your device is connected	Connected
○ White LED light is white	-	-
⊗ White LED light dark white	-	-
● The white LED is off	-	-
Battery low	-	Battery low
Charging	While charging, the red indicator lights up. When full, the red light goes off	-

Description: ○ Indicator light
● Indicate that the light is off
⊗ Indicates that the LED lights dim
※ Indication flash

Power/Charging

For better enjoyment, fully charge the speaker before use. A USB-C charging cable (charge only) is included for standard USB compatible device.

Please use a 5V/2A or above power adapter (not included).
 Caution: - Other incompatible charges may cause damages.
 - Do not use if the connector or device is wet or damaged.

Power On/Off

To turn on the speaker, press and hold the Power On/Off Button for 2 seconds, you will hear a power on tone.
 To turn off the speaker, press and hold the Power On/Off Button for 2 seconds, you will hear a power off tone.
 Caution: If no Bluetooth device is connected, the speaker will turn off in 15 minutes.

Bluetooth Connection

- When first used and turned on, the speaker will automatically enter a waiting mode for connection.
- If the Bluetooth device is already connected, press " ↵ " button to disconnect the current connection and connect with other devices.
- The speaker will automatically enter pairing mode if it is not connected to a Bluetooth device.

When pairing, enable the Bluetooth function of the phone and search for "Monster Musicbox" to connect. When the connection is successful, you will hear a prompt tone and the Bluetooth indicator will turn from blinking to long on.

反面

Music

Press " ○ " once to play or pause music.
 Press " ◀ " once to go to the previous song.
 Press " ▶ " once to go to the next song.
 Turn clockwise/counterclockwise to increase/decrease the master volume.

Micro SD Card Playback

When speaker is on and micro SD card (Not included) is inserted, micro SD card is the priority playback source. If you want to use Bluetooth function, press the " ○ " Button to switch the source.

USB IN (Audio) Playback

When speaker is on and USB drive is inserted, USB IN (Audio) is the priority playback source. If you want to use Bluetooth function, press the " ○ " Button to switch the source.

AUX IN Playback

When speaker is on and audio source is inserted via AUX IN, AUX IN is the priority playback source. If you want to use Bluetooth function, press the " ○ " Button to switch the source.

Power Saving Setting

- In Bluetooth mode, when no device is connected, the speaker will be switched off automatically in 15 minutes.
- AUX IN mode/Micro SD card mode/USB IN (AUDIO) mode or Bluetooth mode, no music playback for 15 minutes, the speaker will be switched off automatically.
- If microphone is plugged in and idled over 15 minutes, the speaker will be switched off automatically.

Light mode

When the speaker is turned on, press the " ✨ " button to switch between various lighting modes. If you want to turn off the light mode, press and hold the " ✨ " button for 2 seconds to turn off the light.

Sound mode

When the speaker is on, press the " BASS " button to switch between different sound modes.

Connect two speakers, stereo mode (same model only)

1. Turn on the two speakers first and do not connect Bluetooth devices (such as mobile phones).
2. Press the " ↵ " button twice on any speaker to hear a prompt tone, and the two speakers will automatically pair. After successful pairing, the Bluetooth indicator light of the main speaker will flash, and the Bluetooth indicator light of the secondary speaker will remain on.
3. Enable the Bluetooth function on the phone, search for "Monster Musicbox" to connect. After successful connection, you will hear a prompt tone, the Bluetooth indicator light on the main speaker will become stays on, and the Bluetooth indicator light on the secondary speaker will remain stays on.

Reset Device

If the speaker needs to be reset, press the reset button.

Caution

- It is not recommended to replace the battery privately.
- The battery (battery pack or battery pack combination) must not be exposed to sunshine, fire or similar overheated environments.

FCC Statement

Changes or modifications not expressly approved by the party responsible for compliance could void the user's authority to operate the equipment. This equipment has been tested and found to comply with the limits for a Class B digital device, pursuant to Part 15 of the FCC Rules. These limits are designed to provide reasonable protection against harmful interference in a residential installation. This equipment generates, uses and can radiate radio frequency energy and, if not installed and used in accordance with the instructions, may cause harmful interference to radio communications. However, there is no guarantee that interference will not occur in a particular installation. If this equipment does cause harmful interference to radio or television reception, which can be determined by turning the equipment off and on, the user is encouraged to try to correct the interference by one or more of the following measures:

- Reorient or relocate the receiving antenna.
- Increase the separation between the equipment and receiver.
- Connect the equipment into an outlet on a circuit different from that to which the receiver is connected.

• Consult the dealer or an experienced radio/TV technician for help.

This device complies with part 15 of the FCC rules. Operation is subject to the following two conditions (1) this device may not cause harmful interference, and (2) this device must accept any interference received, including interference that may cause undesired operation.