

# TEST REPORT

Report No.: BCTC2009001103-1E

---

Applicant: Guangdong Bekey Technology Co., Ltd.

---

Product Name: Wifi range extender

---

Model/Type Ref.: 702403

---

Tested Date: Sep. 15, 2020 to Oct. 20, 2020

---

Issued Date: Oct. 20, 2020

---

**Shenzhen BCTC Testing Co., Ltd.**

# FCC ID: 2AVCH-702403

Product Name: Wifi range extender  
Trademark: N/A  
Model/Type Ref.: 702403  
WD-R750U, WD-R751U, WD-R752U, WD-R753U, WD-R754U  
Prepared For: Guangdong Bekey Technology Co., Ltd.  
Address: R building, DongYuan reservoir region immigration base, Butterfly Lodge Ind District, DongYuan, Heyuan 517500, China  
Manufacturer: Guangdong Bekey Technology Co., Ltd.  
Address: R building, DongYuan reservoir region immigration base, Butterfly Lodge Ind District, DongYuan, Heyuan 517500, China  
Prepared By: Shenzhen BCTC Testing Co., Ltd.  
Address: 1-2F, East of B Building, Pengzhou Industrial, Fuyuan 1st Road, Qiaotou Community, Fuyong Street, Bao'an District, Shenzhen, China  
Sample Received Date: Sep. 15, 2020  
Sample tested Date: Sep. 15, 2020 to Oct. 20, 2020  
Issue Date: Oct. 20, 2020  
Report No.: BCTC2009001103-1E  
FCC Part15.247  
ANSI C63.10:2013  
Test Standards KDB 662911 D01 v02r01  
558074 D01 15.247 Meas Guidance v05r02  
Test Results PASS

Tested by:



Eric Yang/Project Handler

Approved by:



Zero Zhou/Reviewer

*The test report is effective only with both signature and specialized stamp. This result(s) shown in this report refer only to the sample(s) tested. Without written approval of Shenzhen BCTC Testing Co., Ltd, this report can't be reproduced except in full. The tested sample(s) and the sample information are provided by the client.*

## Table of Contents

	Page
<b>1 .VERSION</b>	<b>6</b>
<b>2 . SUMMARY OF TEST RESULTS</b>	<b>7</b>
2.1 MEASUREMENT UNCERTAINTY	8
<b>3 . GENERAL INFORMATION</b>	<b>9</b>
3.1 GENERAL DESCRIPTION OF EUT	9
3.2 DESCRIPTION OF TEST MODES	10
3.3 BLOCK DIGRAM SHOWING THE CONFIGURATION OF SYSTEM TESTED	11
3.4 DESCRIPTION OF SUPPORT UNITS(CONDUCTED MODE)	11
3.5 EQUIPMENTS LIST FOR ALL TEST ITEMS	12
3.5.1TEST FACILITY	12
<b>4 . EMC EMISSION TEST</b>	<b>14</b>
4.1 CONDUCTED EMISSION MEASUREMENT	14
4.1.1 POWER LINE CONDUCTED EMISSION LIMITS	14
4.1.2 TEST PROCEDURE	14
4.1.3 DEVIATION FROM TEST STANDARD	14
4.1.4 TEST SETUP	15
4.1.5 EUT OPERATING CONDITIONS	15
4.1.6 TEST RESULTS	16
4.2 RADIATED EMISSION MEASUREMENT	18
4.2.1 RADIATED EMISSION LIMITS	18
4.2.2 TEST PROCEDURE	19
4.2.3 DEVIATION FROM TEST STANDARD	19
4.2.4 TEST SETUP	19
4.2.5 EUT OPERATING CONDITIONS	20
4.2.6 TEST RESULTS (BETWEEN 9KHZ – 30 MHZ)	21
4.2.7 TEST RESULTS (BETWEEN 30MHZ – 1GHZ)	22
4.2.8 TEST RESULTS	24
4.3 RADIATED BAND EMISSION MEASUREMENT	30
4.3.1 TEST REQUIREMENT:	30
4.3.2 TEST PROCEDURE	30
4.3.3 DEVIATION FROM TEST STANDARD	31
4.3.4 TEST SETUP	31
4.3.5 EUT OPERATING CONDITIONS	31

**Table of Contents**

	Page
<b>5 . POWER SPECTRAL DENSITY TEST</b>	<b>35</b>
5.1 APPLIED PROCEDURES / LIMIT	35
5.1.1 TEST PROCEDURE	35
5.1.2 DEVIATION FROM STANDARD	35
5.1.3 TEST SETUP	35
5.1.4 EUT OPERATION CONDITIONS	35
5.1.5 TEST RESULTS	35
<b>6 . BANDWIDTH TEST</b>	<b>44</b>
6.1 APPLIED PROCEDURES / LIMIT	44
6.1.1 TEST PROCEDURE	44
6.1.2 DEVIATION FROM STANDARD	44
6.1.3 TEST SETUP	44
6.1.4 EUT OPERATION CONDITIONS	44
6.1.5 TEST RESULTS	45
<b>7 . PEAK OUTPUT POWER TEST</b>	<b>53</b>
7.1 APPLIED PROCEDURES/LIMIT	53
7.1.1 TEST PROCEDURE	53
7.1.2 DEVIATION FROM STANDARD	53
7.1.3 TEST SETUP	53
7.1.4 EUT OPERATION CONDITIONS	53
7.1.5 TEST RESULTS	54
<b>8 . 100 KHZ BANDWIDTH OF FREQUENCY BAND EDGE</b>	<b>55</b>
8.1 APPLICABLE STANDARD	55
8.2 TEST PROCEDURE	55
8.3 DEVIATION FROM STANDARD	55
8.4 TEST SETUP	55
8.5 EUT OPERATION CONDITIONS	55
<b>9 . DUTY CYCLE OF TEST SIGNAL</b>	<b>64</b>
9.1 STANDARD REQUIREMENT	64
9.2 FORMULA:	64
<b>10 . ANTENNA REQUIREMENT</b>	<b>67</b>
10.1 STANDARD REQUIREMENT	67
10.2 EUT ANTENNA	67

**Table of Contents**

	<b>Page</b>
<b>11 . EUT TEST PHOTO</b>	<b>68</b>
<b>12 . EUT PHOTO</b>	<b>70</b>
<b>APPENDIX-PHOTOGRAPHS OF EUT CONSTRUCTIONAL DETAILS</b>	

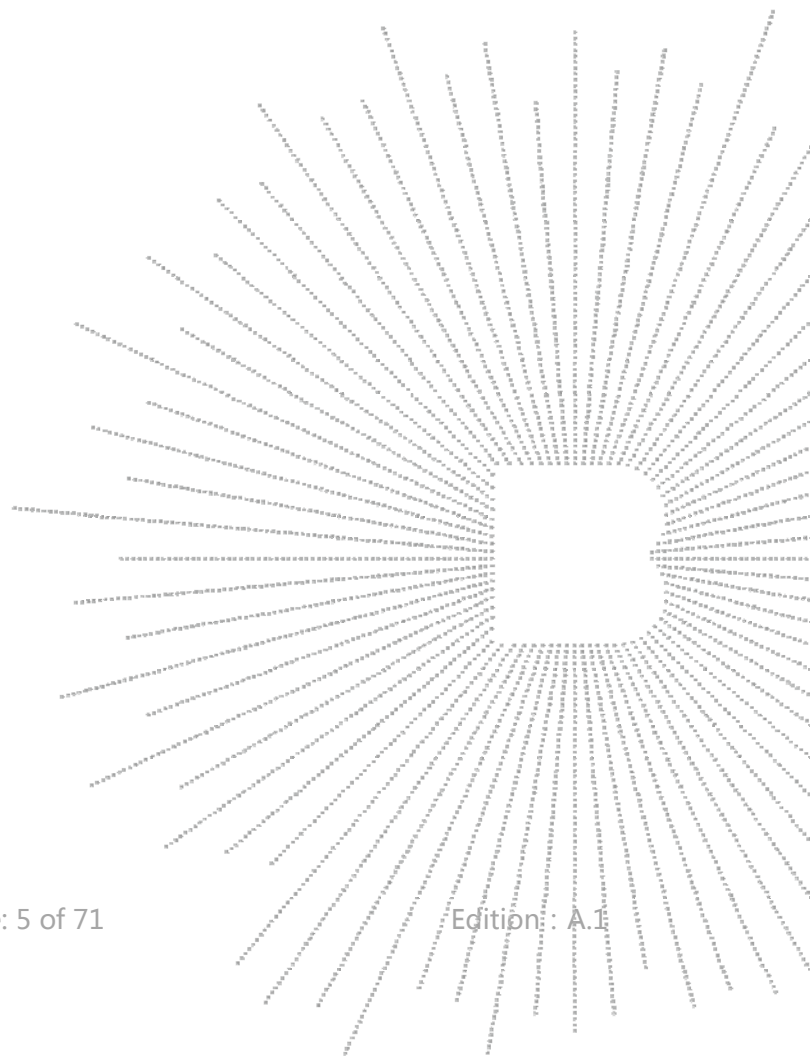

**1.VERSION**

Report No.	Issue Date	Description	Approved
BCTC2009001103-1E	Oct. 20, 2020	Original	Valid

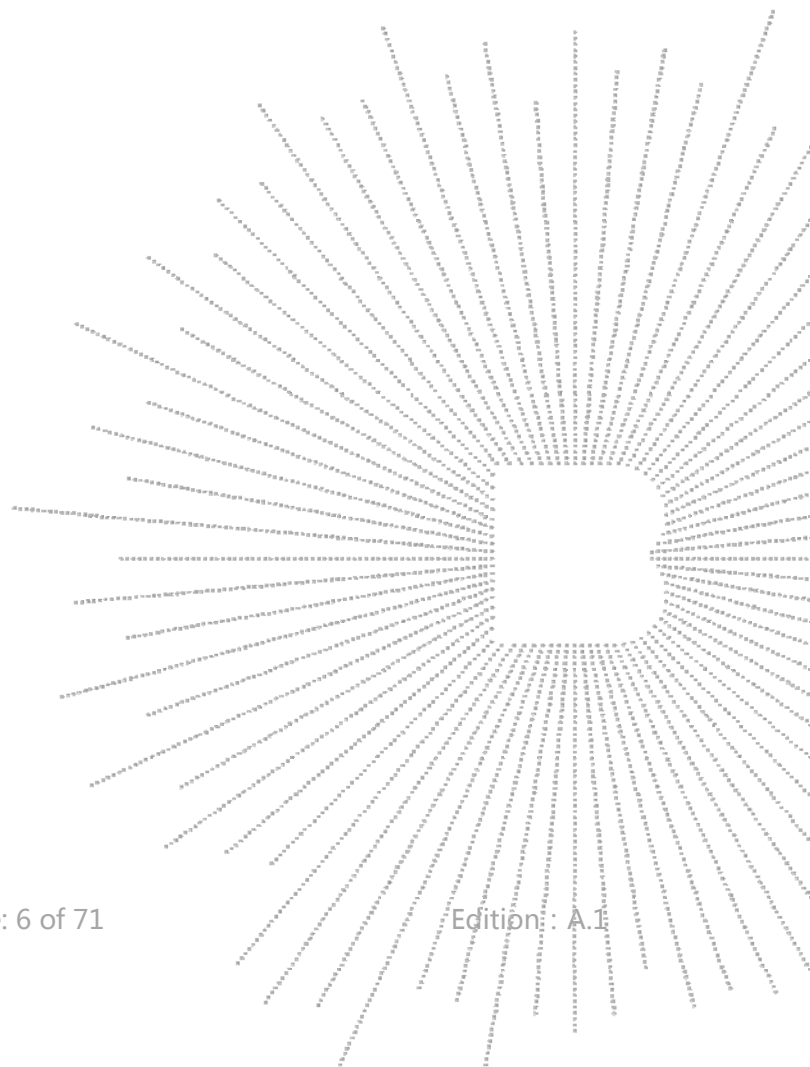

## 2. SUMMARY OF TEST RESULTS

Test procedures according to the technical standards:

FCC Part15 (15.247) , Subpart C			
Standard Section	Test Item	Judgment	Remark
15.207	Conducted Emission	PASS	
15.247 (a)(2)	6dB Bandwidth	PASS	
15.247 (b)	Peak Output Power	PASS	
15.247 (d)	Radiated Spurious Emission	PASS	
15.247 (e)	Power Spectral Density	PASS	
15.205	Restricted Band of Operation	PASS	
15.247 (d)	Band Edge (Out of Band Emissions)	PASS	
15.203	Antenna Requirement	PASS	

**NOTE:**

(1) "N/A" denotes test is not applicable in this Test Report

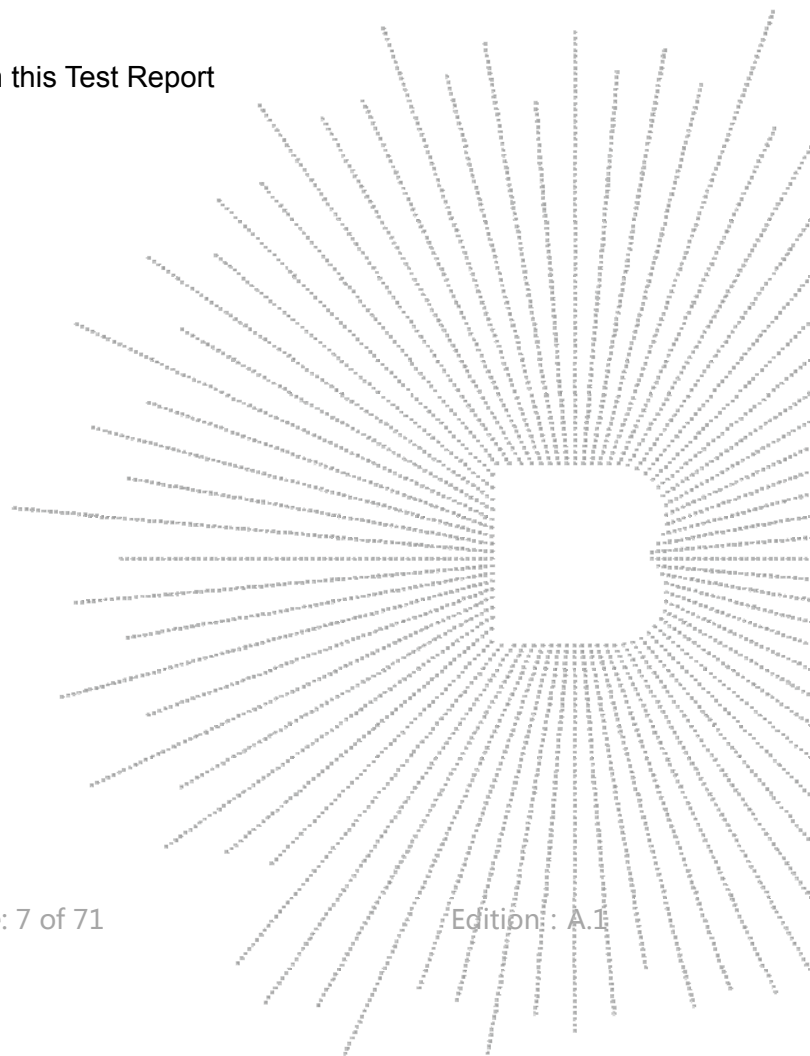

## 2.1 MEASUREMENT UNCERTAINTY

The reported uncertainty of measurement  $y \pm U$ , where expanded uncertainty  $U$  is based on a standard uncertainty multiplied by a coverage factor of  $k=2$ , providing a level of confidence of approximately **95 %**.

No.	Item	Uncertainty
1	3m chamber Radiated spurious emission(30MHz-1GHz)	U=4.3dB
2	3m chamber Radiated spurious emission(1GHz-18GHz)	U=4.5dB
3	3m chamber Radiated spurious emission(18GHz-40GHz)	U=3.34dB
4	Conducted Adjacent channel power	U=1.38dB
5	Conducted output power uncertainty Above 1G	U=1.576dB
6	Conducted output power uncertainty below 1G	U=1.28dB
7	humidity uncertainty	U=5.3%
8	Temperature uncertainty	U=0.59°C

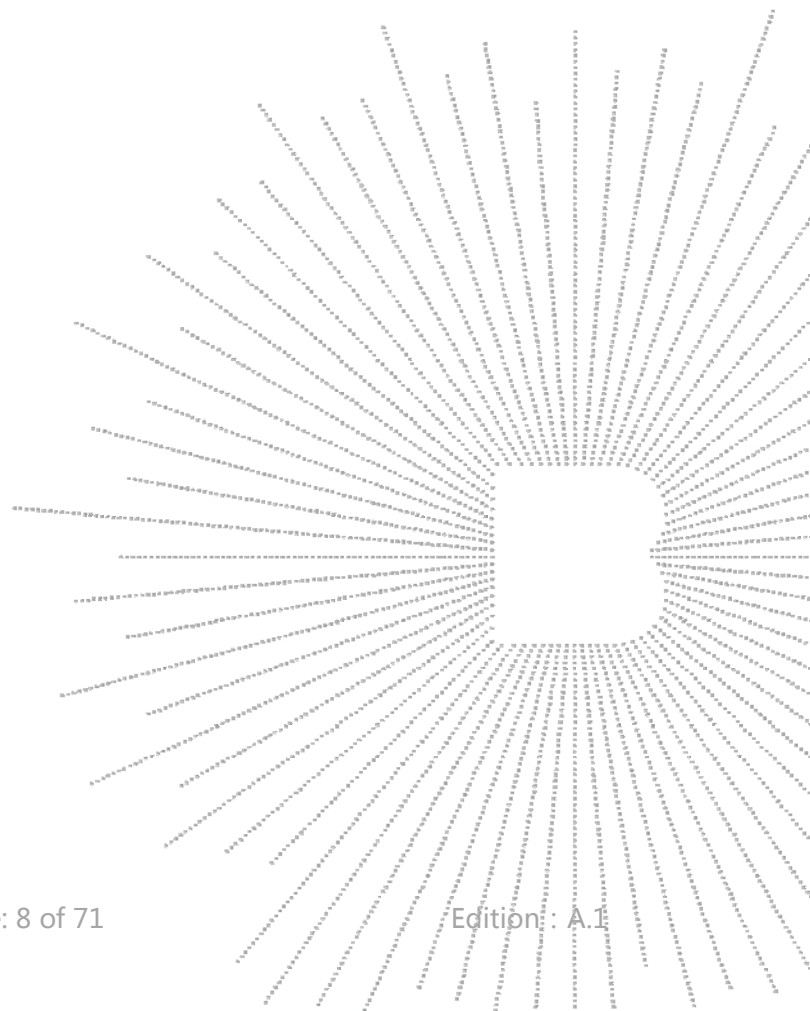



### 3. GENERAL INFORMATION

#### 3.1 GENERAL DESCRIPTION OF EUT

Model/Type Ref.:	702403 WD-R750U, WD-R751U, WD-R752U, WD-R753U, WD-R754U
Model differences:	All the model are the same circuit and RF module, except model names.
Operation Frequency:	802.11b/g/n20MHz:2412~2462 MHz 802.11n40MHz:2422~2452 MHz
Bit Rate of Transmitter	802.11b:11/5.5/2/1 Mbps 802.11g:54/48/36/24/18/12/9/6Mbps 802.11n Up to 150Mbps
Type of Modulation:	WIFI: OFDM/DSSS
Number Of Channel	802.11b/g/n20MHz:11 CH 802.11n40MHz: 7 CH
Antenna installation:	WIFI: External antenna
Antenna Gain:	WIFI: Antenna A:2dBi Antenna B: 2dBi
Ratings:	AC120V/60Hz

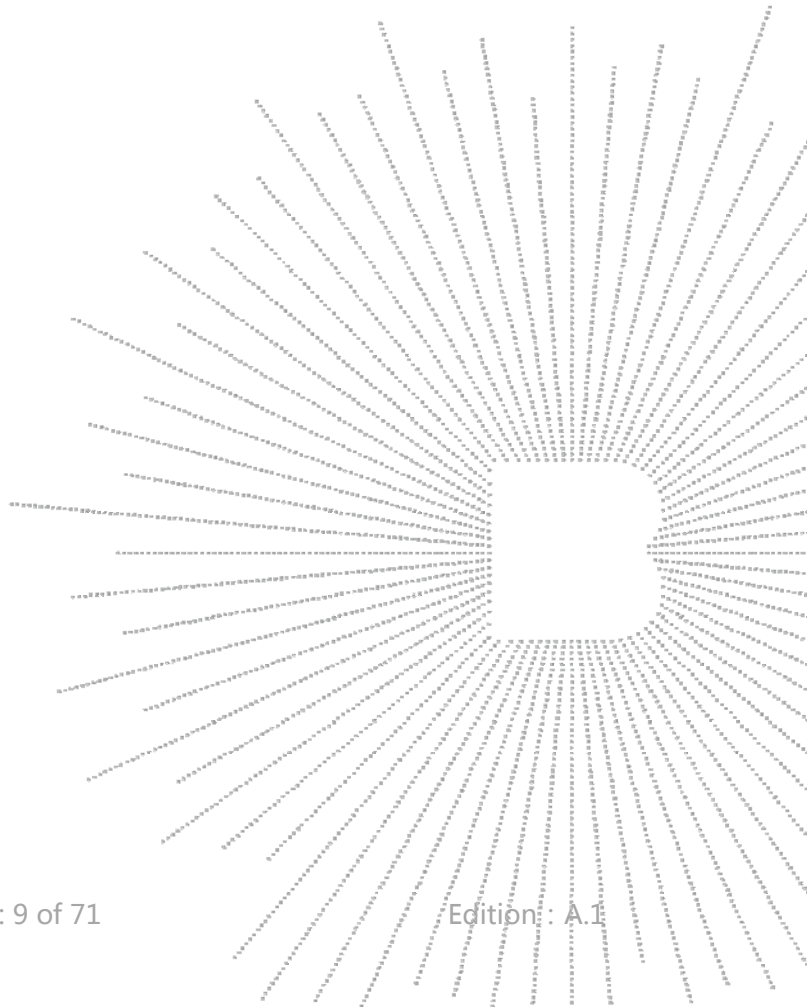

1.

Channel List for 802.11b/g/n(20)							
Channel	Frequency (MHz)	Channel	Frequency (MHz)	Channel	Frequency (MHz)	Channel	Frequency (MHz)
01	2412	04	2427	07	2442	10	2457
02	2417	05	2432	08	2447	11	2462
03	2422	06	2437	09	2452		

Channel List for 802.11n(40)							
Channel	Frequency (MHz)	Channel	Frequency (MHz)	Channel	Frequency (MHz)	Channel	Frequency (MHz)
03	2422	05	2432	07	2442	09	2452
04	2427	06	2437	08	2447		

2

Table for External antenna

Ant.	Antenna Type	Gain (dBi)	NOTE
A	External antenna	2	
B	External antenna	2	

EUT has two PCB antennas with Max gain GANT 2dBi on every antenna, CDD device with two spatial streams, also can operate with one spatial streams according to KDB662911 D01 v02r01,

Directional gain= GANT + Array Gain, where Array Gain is as follows.

- 1) For power spectral density(PSD) measurements,

$$\text{Array Gain} = 10 \log(\text{NANT}/\text{NSS}) \text{dB} = 10 \log(2/1) = 3.01 \text{dB},$$

So the directional gain for PSD is 5.01dBi

- 2) For power measurements,

The Array gain=0 dB for  $\text{NANT} \leq 4$ ,

So the directional gain for Power measurements is 2dBi

### 3.2 DESCRIPTION OF TEST MODES

Pretest Mode	Description
Mode 1	802.11b CH1/ CH6/ CH11
Mode 2	802.11g CH1/ CH6/ CH11
Mode 3	802.11n20 CH1/ CH6/ CH11
Mode 4	802.11n40 CH3/ CH6/ CH9
Mode 5	Link Mode

Conducted Emission	
Final Test Mode	Description
Mode 5	Link Mode

For Radiated Emission	
Final Test Mode	Description
Mode 1	802.11b CH1/ CH6/ CH11
Mode 2	802.11g CH1/ CH6/ CH11

Mode 3	802.11n20 CH1/ CH6/ CH11
Mode 4	802.11n40 CH3/ CH6/ CH9

Note:

(1) The measurements are performed at all Bit Rate of Transmitter, the worst data was reported.

### 3.3 BLOCK DIGRAM SHOWING THE CONFIGURATION OF SYSTEM TESTED

Conducted Emission Test/ Radiated Spurious Emission

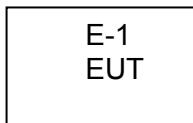

### 3.4 DESCRIPTION OF SUPPORT UNITS(CONDUCTED MODE)

The EUT has been tested as an independent unit together with other necessary accessories or support units. The following support units or accessories were used to form a representative test configuration during the tests.

No.	Device Type	Brand	Model	Series No.	Data Cable	Power Cord
E-1	Wifi range extender	N/A	702403	N/A	EUT	E-1

Item	Shielded Type	Ferrite Core	Length	Note

Note:

- (1) The support equipment was authorized by Declaration of Confirmation.
- (2) For detachable type I/O cable should be specified the length in cm in 「Length」 column.

### 3.5 EQUIPMENTS LIST FOR ALL TEST ITEMS

#### 3.5.1 TEST FACILITY

All measurement facilities used to collect the measurement data are located at Shenzhen BCTC Testing Co., Ltd. Address: 1-2F, East of B Building, Pengzhou Industrial, Fuyuan 1st Road, Qiaotou Community, Fuyong Street, Bao'an District, Shenzhen, China. The site and apparatus are constructed in conformance with the requirements of ANSI C63.4 and CISPR 16-1-1 other equivalent standards.

FCC Test Firm Registration Number: 712850

IC Registered No.: 23583

#### Radiation Test equipment

Item	Equipment	Manufacturer	Type No.	Serial No.	Last calibration	Calibrated until
1	Spectrum Analyzer (9kHz-26.5GHz)	Agilent	E4407B	MY45109572	Jun. 08, 2020	Jun. 07, 2021
2	Test Receiver (9kHz-7GHz)	R&S	ESR7	101154	Jun. 08, 2020	Jun. 07, 2021
3	Bilog Antenna (30MHz-3GHz)	SCHWARZBECK	VULB9163	VULB9163-942	Jun. 08, 2020	Jun. 07, 2021
4	Horn Antenna (1GHz-18GHz)	SCHWARZBECK	BBHA9120D	1541	Jun. 10, 2020	Jun. 09, 2021
5	Horn Antenna (18GHz-40GHz)	SCHWARZBECK	BBHA9170	00822	Jun. 10, 2020	Jun. 09, 2021
6	Amplifier (9kHz-6GHz)	SCHWARZBECK	BBV9744	9744-0037	Jun. 04, 2020	Jun. 03, 2021
7	Amplifier (0.5GHz-18GHz)	SCHWARZBECK	BBV9718	9718-309	Jun. 04, 2020	Jun. 03, 2021
8	Amplifier (18GHz-40GHz)	MITEQ	TTA1840-35-HG	2034381	Jun. 08, 2020	Jun. 07, 2021
9	Loop Antenna (9kHz-30MHz)	SCHWARZBECK	FMZB1519B	00014	Jun. 08, 2020	Jun. 07, 2021
10	RF cables1 (9kHz-30MHz)	Huber+Suhnar	9kHz-30MHz	B1702988-0008	Jun. 08, 2020	Jun. 07, 2021
11	RF cables2 (30MHz-1GHz)	Huber+Suhnar	30MHz-1GHz	1486150	Jun. 08, 2020	Jun. 07, 2021
12	RF cables3 (1GHz-40GHz)	Huber+Suhnar	1GHz-40GHz	1607106	Jun. 08, 2020	Jun. 07, 2021
13	Power Metter	Keysight	E4419B	\	Jun. 08, 2020	Jun. 07, 2021
14	Power Sensor (AV)	Keysight	E9 300A	\	Jun. 08, 2020	Jun. 07, 2021
15	Signal Analyzer 20kHz-26.5GHz	KEYSIGHT	N9020A	MY49100060	Jun. 04, 2020	Jun. 03, 2021
16	Spectrum Analyzer 9kHz-40GHz	Agilent	FSP40	100363	Jun. 13, 2020	Jun. 12, 2021
17	D.C. Power Supply	LongWei	TPR-6405D	\	\	\
18	Software	Frad	EZ-EMC	FA-03A2 RE	\	\

## Conduction Test equipment

Item	Equipment	Manufacturer	Type No.	Serial No.	Last calibration	Calibrated until
1	Test Receiver	R&S	ESR3	102075	Jun. 08, 2020	Jun. 07, 2021
2	LISN	SCHWARZBECK	NSLK8127	8127739	Jun. 13, 2020	Jun. 12, 2021
3	LISN	R&S	ENV216	101375	Jun. 04, 2020	Jun. 03, 2021
4	RF cables	Huber+Suhnar	9kHz-30MHz	B1702988-0008	Jun. 08, 2020	Jun. 07, 2021
5	Software	Frad	EZ-EMC	EMC-CON 3A1	\	\

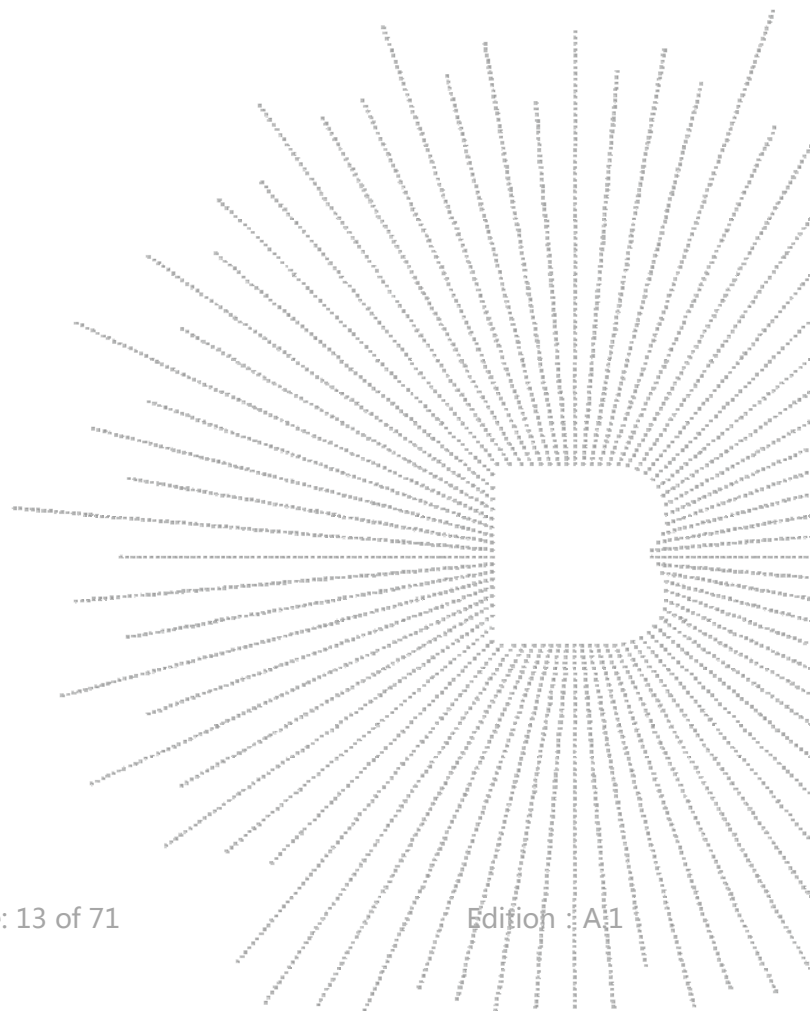

## 4. EMC EMISSION TEST

### 4.1 CONDUCTED EMISSION MEASUREMENT

#### 4.1.1 POWER LINE CONDUCTED EMISSION Limits (Frequency Range 150KHz-30MHz)

FREQUENCY (MHz)	Limit (dBuV)		Standard
	Quasi-peak	Average	
0.15 -0.5	66 - 56 *	56 - 46 *	FCC
0.50 -5.0	56.00	46.00	FCC
5.0 -30.0	60.00	50.00	FCC

Note:

- (1) The tighter limit applies at the band edges.
- (2) The limit of " \* " marked band means the limitation decreases linearly with the logarithm of the frequency in the range.

The following table is the setting of the receiver

Receiver Parameters	Setting
Attenuation	10 dB
Start Frequency	0.15 MHz
Stop Frequency	30 MHz
IF Bandwidth	9 kHz

#### 4.1.2 TEST PROCEDURE

- a. The EUT was placed 0.8 meters from the horizontal ground plane with EUT being connected to the power mains through a line impedance stabilization network (LISN). All other support equipments powered from additional LISN(s). The LISN provide 50 Ohm/ 50uH of coupling impedance for the measuring instrument.
- b. Interconnecting cables that hang closer than 40 cm to the ground plane shall be folded back and forth in the center forming a bundle 30 to 40 cm long.
- c. I/O cables that are not connected to a peripheral shall be bundled in the center. The end of the cable may be terminated, if required, using the correct terminating impedance. The overall length shall not exceed 1 m.
- d. LISN at least 80 cm from nearest part of EUT chassis.
- e. For the actual test configuration, please refer to the related Item –EUT Test Photos.

#### 4.1.3 DEVIATION FROM TEST STANDARD

No deviation

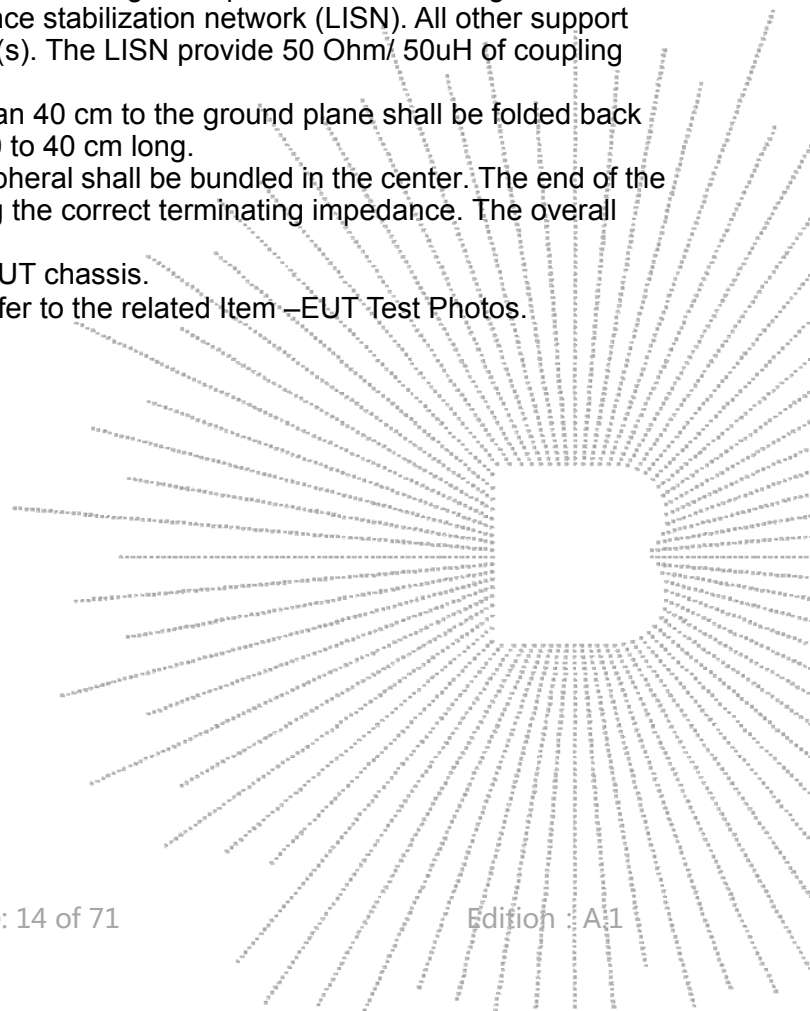

#### 4.1.4 TEST SETUP

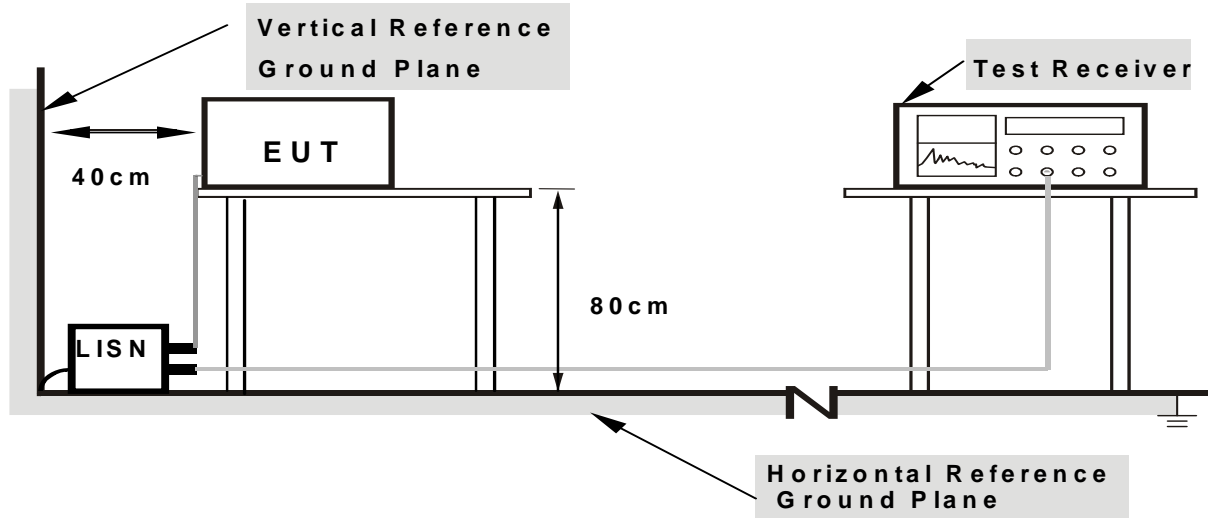

- Note:**
- 1. Support units were connected to second LISN.
  - 2. Both of LISNs (AMN) are 80 cm from EUT and at least 80 cm from other units and other metal planes

#### 4.1.5 EUT OPERATING CONDITIONS

The EUT was configured for testing in a typical fashion (as a customer would normally use it). The EUT has been programmed to continuously transmit during test. This operating condition was tested and used to collect the included data.

We pretest AC 120V and AC 240V, the worst voltage was AC 120V and the data recording in the report.

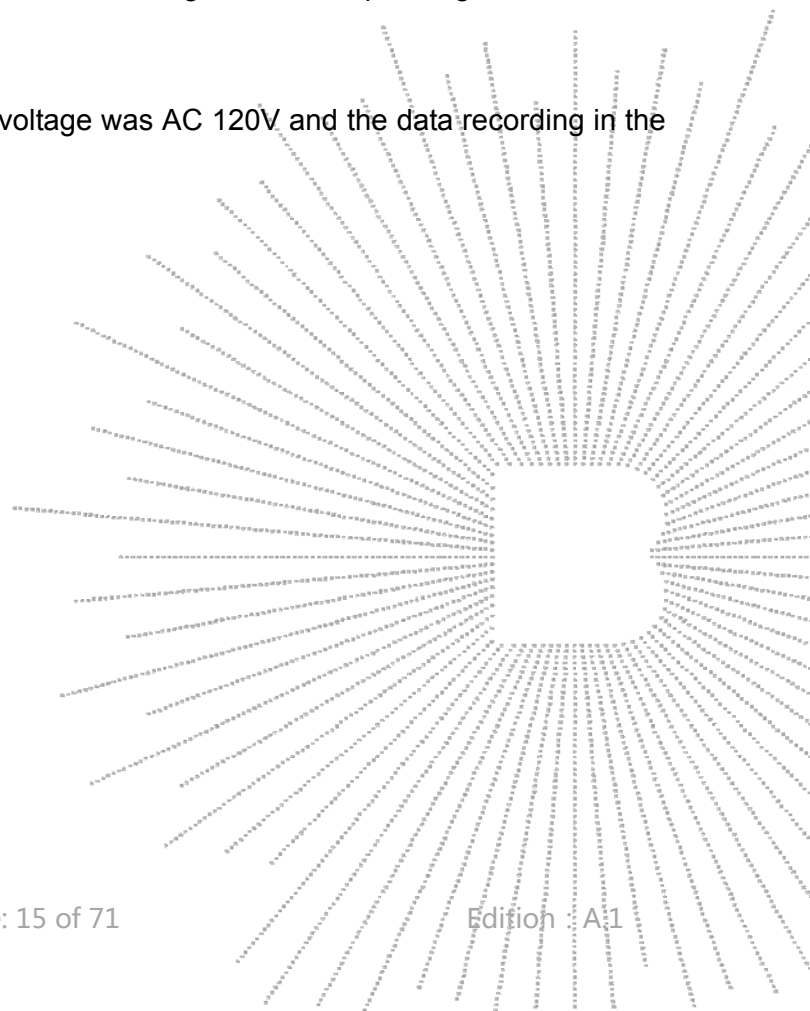

### 4.1.6 TEST RESULTS

Temperature :	26 °C	Relative Humidity :	54%
Pressure :	101kPa	Phase :	L
Test Voltage :	AC 120V/60Hz	Test Mode :	Mode 5

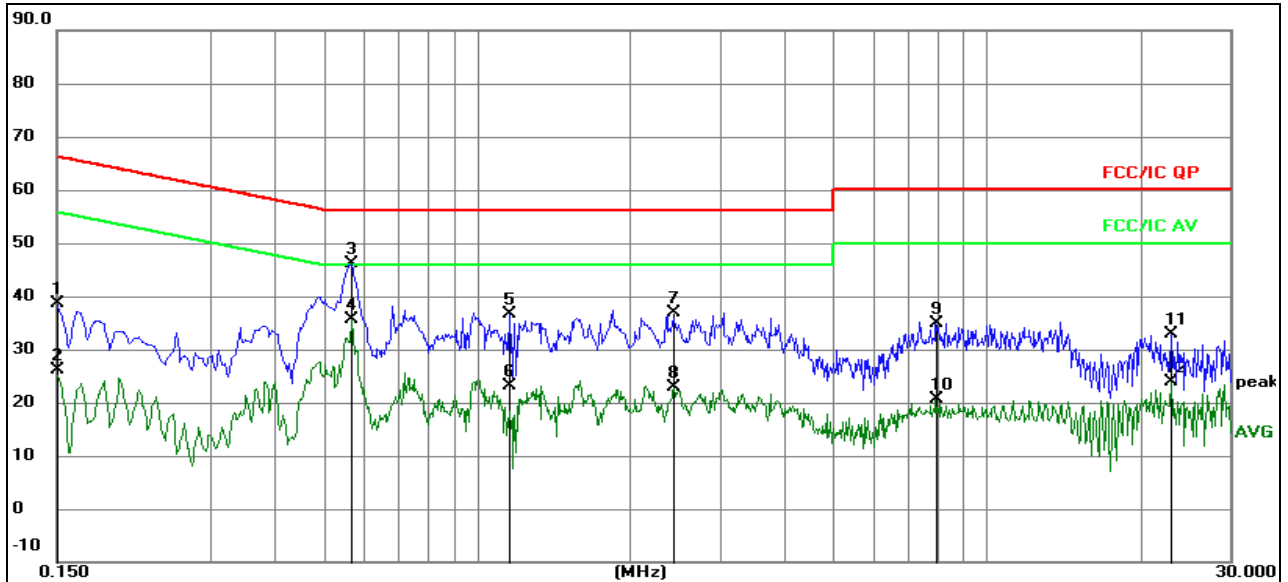

Remark:

1. All readings are Quasi-Peak and Average values.
2. Factor = Insertion Loss + Cable Loss.

No.	Mk.	Freq. MHz	Reading Level	Correct Factor	Measure- ment	Limit	Over	Detector	Comment
				dB	dBuV	dBuV	dB		
1		0.1500	29.00	9.52	38.52	66.00	-27.48	QP	
2		0.1500	16.57	9.52	26.09	56.00	-29.91	AVG	
3	*	0.5670	36.30	9.86	46.16	56.00	-9.84	QP	
4		0.5670	25.69	9.86	35.55	46.00	-10.45	AVG	
5		1.1595	27.03	9.57	36.60	56.00	-19.40	QP	
6		1.1595	13.61	9.57	23.18	46.00	-22.82	AVG	
7		2.4346	27.29	9.62	36.91	56.00	-19.09	QP	
8		2.4346	13.15	9.62	22.77	46.00	-23.23	AVG	
9		7.9353	25.15	9.71	34.86	60.00	-25.14	QP	
10		7.9353	10.87	9.71	20.58	50.00	-29.42	AVG	
11		23.0181	23.00	9.76	32.76	60.00	-27.24	QP	
12		23.0181	14.05	9.76	23.81	50.00	-26.19	AVG	

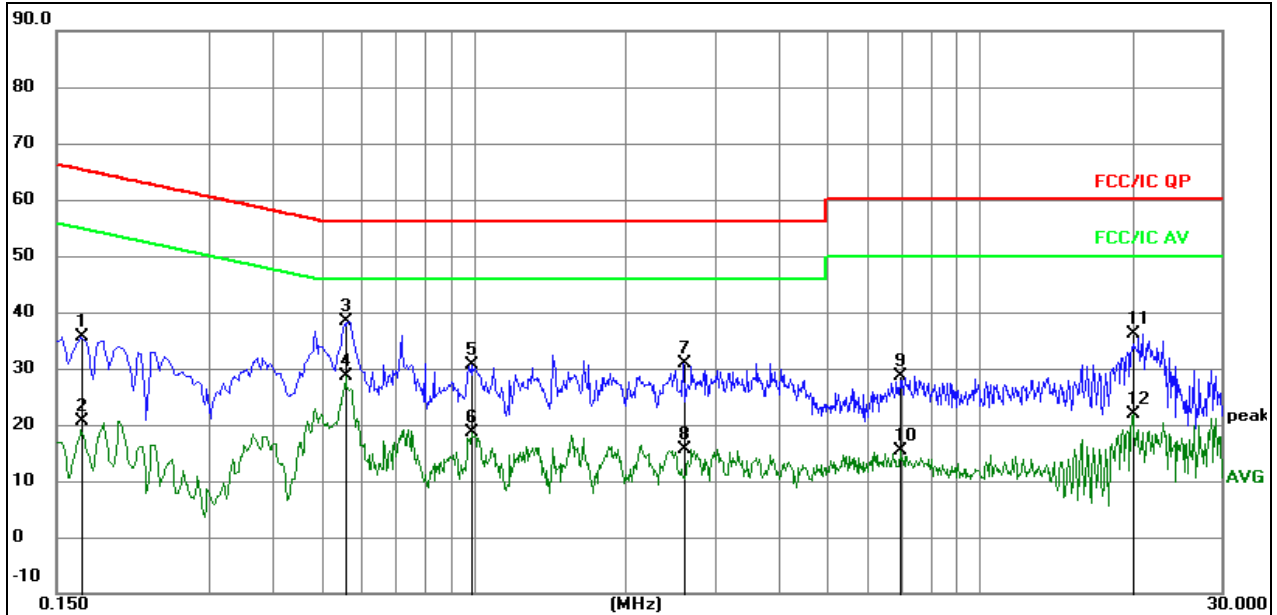

Temperature :	26 °C	Relative Humidity :	54%
Pressure :	101kPa	Phase :	N
Test Voltage :	AC 120V/60Hz	Test Mode :	Mode 5

**Remark:**

1. All readings are Quasi-Peak and Average values.
2. Factor = Insertion Loss + Cable Loss.

No.	Mk.	Freq. MHz	Reading Level	Correct Factor dB	Measure- ment dBuV	Limit dBuV	Over dB	Detector	Comment
1		0.1680	26.13	9.50	35.63	65.06	-29.43	QP	
2		0.1680	11.22	9.50	20.72	55.06	-34.34	AVG	
3		0.5595	28.64	9.83	38.47	56.00	-17.53	QP	
4	*	0.5595	18.87	9.83	28.70	46.00	-17.30	AVG	
5		0.9915	21.00	9.57	30.57	56.00	-25.43	QP	
6		0.9915	9.17	9.57	18.74	46.00	-27.26	AVG	
7		2.5980	21.24	9.63	30.87	56.00	-25.13	QP	
8		2.5980	6.02	9.63	15.65	46.00	-30.35	AVG	
9		6.9765	18.90	9.72	28.62	60.00	-31.38	QP	
10		6.9765	5.57	9.72	15.29	50.00	-34.71	AVG	
11		20.0985	26.39	9.79	36.18	60.00	-23.82	QP	
12		20.0985	12.00	9.79	21.79	50.00	-28.21	AVG	

## 4.2 RADIATED EMISSION MEASUREMENT

### 4.2.1 RADIATED EMISSION LIMITS (Frequency Range 9kHz-1000MHz)

20dBc in any 100 kHz bandwidth outside the operating frequency band. In case the emission fall within the restricted band specified on 15.205(a), then the 15.209(a) limit in the table below has to be followed.

Frequencies (MHz)	Field Strength (micorvolts/meter)	Measurement Distance (meters)
0.009~0.490	2400/F(KHz)	300
0.490~1.705	24000/F(KHz)	30
1.705~30.0	30	30
30~88	100	3
88~216	150	3
216~960	200	3
Above 960	500	3

### LIMITS OF RADIATED EMISSION MEASUREMENT (Above 1000MHz)

FREQUENCY (MHz)	Limit (dBuV/m) (at 3M)	
	PEAK	AVERAGE
Above 1000	74	54

Notes:

- (1) The limit for radiated test was performed according to FCC PART 15C.
- (2) The tighter limit applies at the band edges.
- (3) Emission level (dBuV/m)=20log Emission level (uV/m).

Spectrum Parameter	Setting
Attenuation	Auto
Start Frequency	1000 MHz
Stop Frequency	25GHz
RB / VB (emission in restricted band)	1 MHz / 1 MHz for Peak, 1 MHz / 10Hz for Average

Receiver Parameter	Setting
Attenuation	Auto
Start ~ Stop Frequency	9kHz~150kHz / RB 200Hz for QP
Start ~ Stop Frequency	150kHz~30MHz / RB 9kHz for QP
Start ~ Stop Frequency	30MHz~1000MHz / RB 120kHz for QP

#### 4.2.2 TEST PROCEDURE

Below 1GHz test procedure as below:

- a. The EUT was placed on the top of a rotating table 0.8 meters above the ground at a 3 meter semi-anechoic chamber. The table was rotated 360 degrees to determine the position of the highest radiation.
- b. The EUT was set 3 meters away from the interference-receiving antenna, which was mounted on the top of a variable-height antenna tower.
- c. The antenna height is varied from one meter to four meters above the ground to determine the maximum value of the field strength. Both horizontal and vertical polarizations of the antenna are set to make the measurement.
- d. For each suspected emission, the EUT was arranged to its worst case and then the antenna was tuned to heights from 1 meter to 4 meters (for the test frequency of below 30MHz, the antenna was tuned to heights 1 meter) and the rotatable table was turned from 0 degrees to 360 degrees to find the maximum reading.
- e. The test-receiver system was set to Peak Detect Function and Specified Bandwidth with Maximum Hold Mode.
- f. If the emission level of the EUT in peak mode was 10dB lower than the limit specified, then testing could be stopped and the peak values of the EUT would be reported. Otherwise the emissions that did not have 10dB margin would be re-tested one by one using peak, quasi-peak or average method as specified and then reported in a data sheet.

Above 1GHz test procedure as below:

- g. Different between above is the test site, change from Semi- Anechoic Chamber to fully Anechoic Chamber and change form table 0.8 metre to 1.5 metre( Above 18GHz the distance is 1 meter and table is 1.5 metre).
- h. Test the EUT in the lowest channel ,the middle channel ,the Highest channel

Note:

Both horizontal and vertical antenna polarities were tested and performed pretest to three orthogonal axis. The worst case emissions were reported

#### 4.2.3 DEVIATION FROM TEST STANDARD

No deviation

#### 4.2.4 TEST SETUP

(A) Radiated Emission Test-Up Frequency Below 30MHz

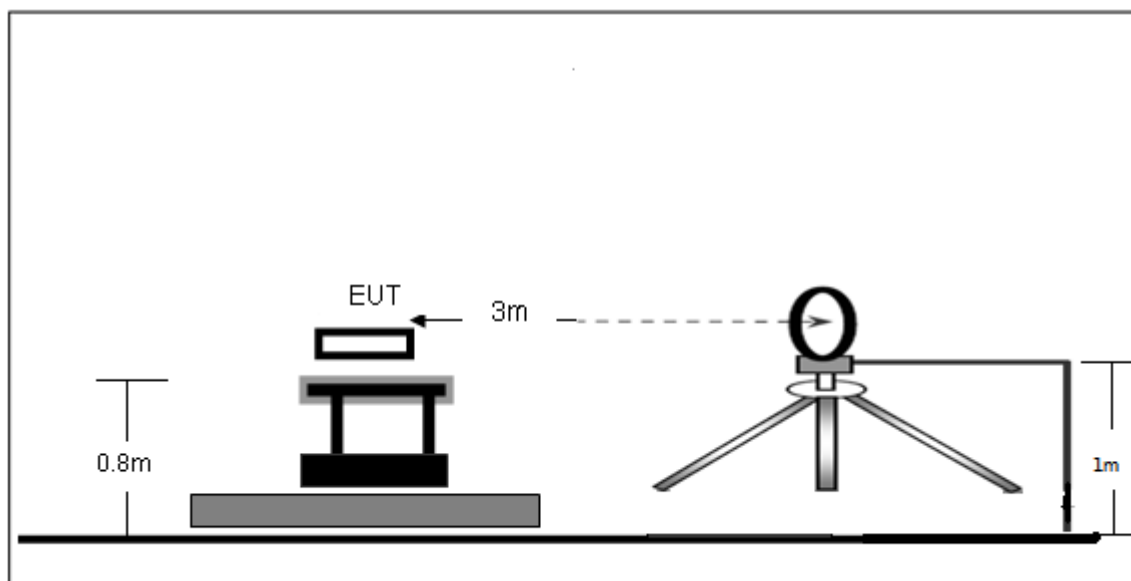

(B) Radiated Emission Test-Up Frequency 30MHz~1GHz

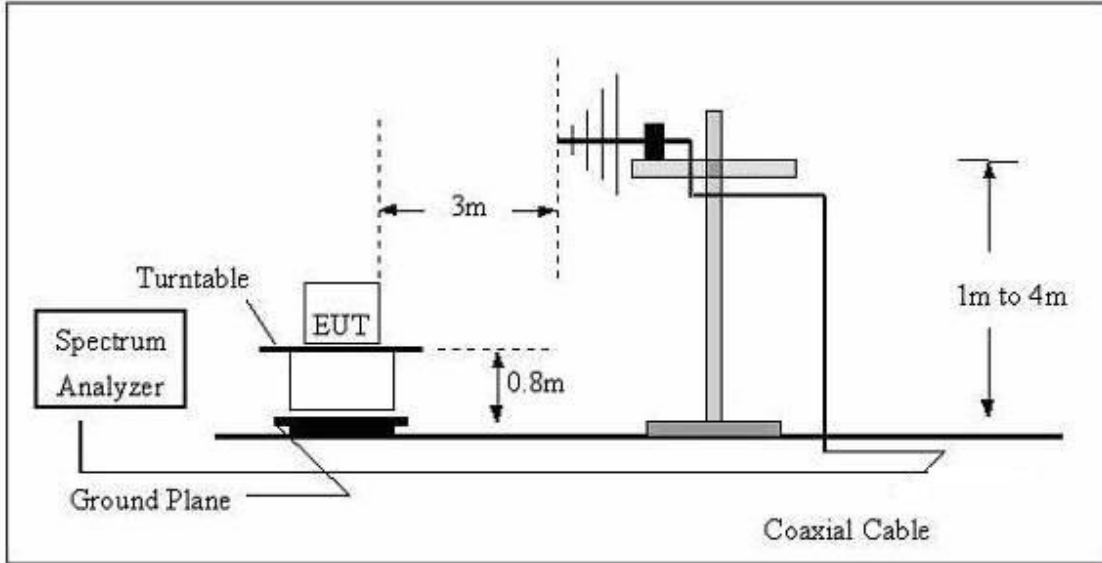

(C) Radiated Emission Test-Up Frequency Above 1GHz

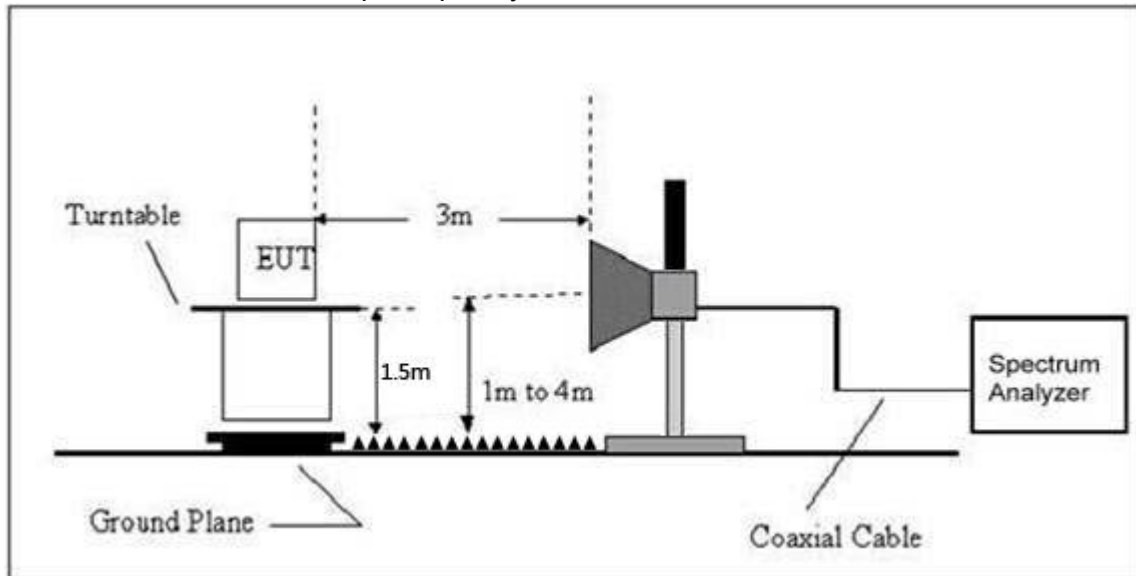

**4.2.5 EUT OPERATING CONDITIONS**

The EUT tested system was configured as the statements of 2.4 Unless otherwise a special operating condition is specified in the follows during the testing.

**4.2.6 TEST RESULTS (BETWEEN 9KHZ – 30 MHZ)**

Temperature:	26 °C	Relative Humidity :	54%
Pressure:	101kPa	Test Voltage :	AC 120V/60Hz
Test Mode :	Mode 5	Polarization :	--

Freq. (MHz)	Reading (dBuV/m)	Limit (dBuV/m)	Margin (dB)	State P/F
--	--	--	--	PASS
--	--	--	--	PASS

**NOTE:**

The amplitude of spurious emissions which are attenuated by more than 20dB below the permissible value has no need to be reported.

Distance extrapolation factor =  $40 \log(\text{specific distance}/\text{test distance})$ (dB);

Limit line = specific limits(dBuv) + distance extrapolation factor.

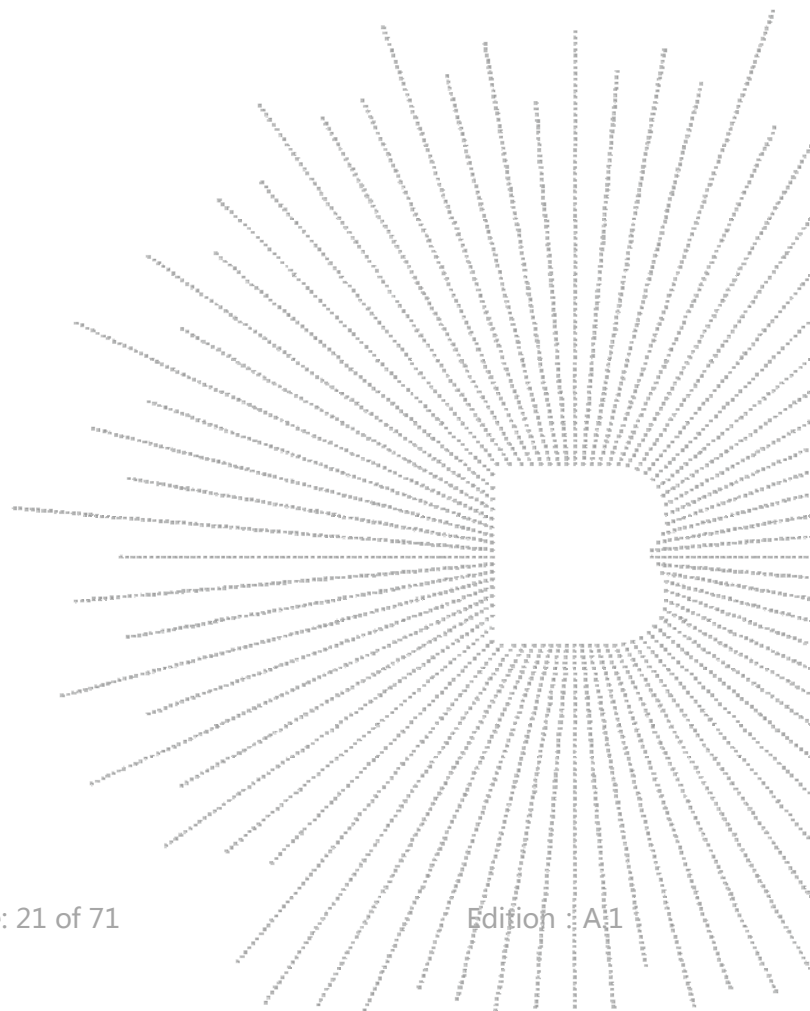

**4.2.7 TEST RESULTS (BETWEEN 30MHZ – 1GHZ)**

Temperature :	26 °C	Relative Humidity :	54%
Pressure :	101 kPa	Polarization :	Horizontal
Test Voltage :	AC 120V/60Hz	Test Mode :	Mode 5

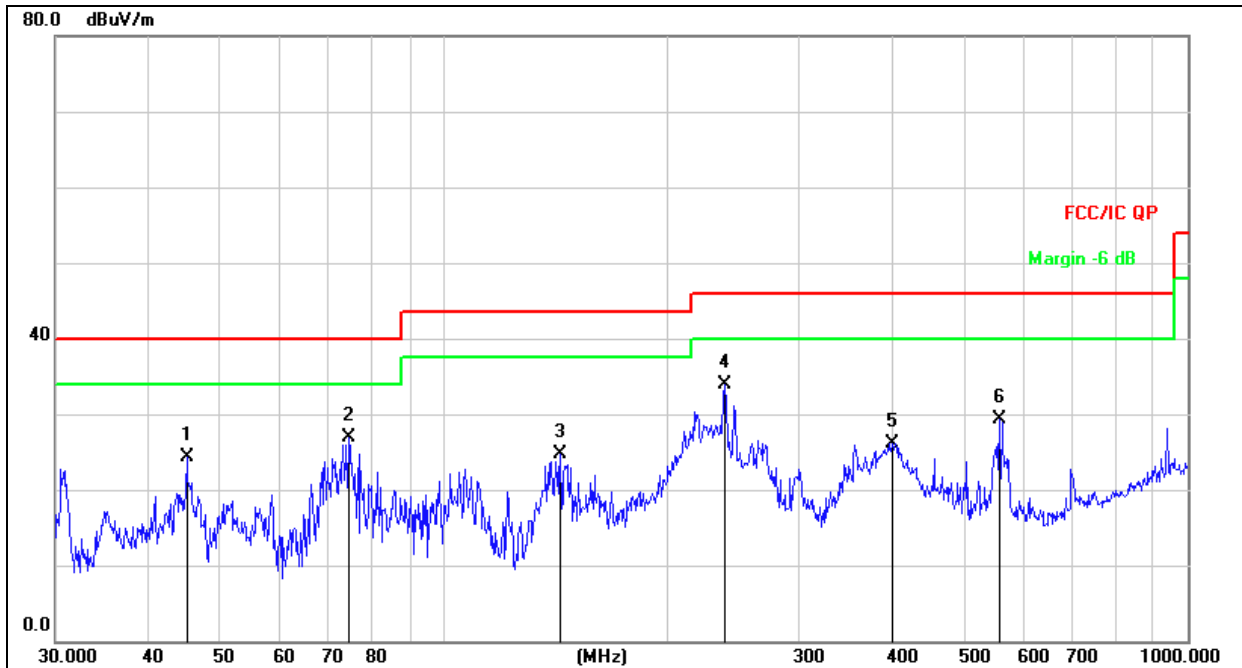

Remark:  
Factor = Antenna Factor + Cable Loss – Pre-amplifier.

No.	Mk.	Freq. MHz	Reading Level dBuV	Correct Factor dB	Measure- ment dBuV/m	Limit dB/m	Over dB	Detector
1		45.0583	39.36	-15.13	24.23	40.00	-15.77	QP
2		74.3955	46.02	-19.17	26.85	40.00	-13.15	QP
3		143.3261	43.78	-19.07	24.71	43.50	-18.79	QP
4	*	238.3102	49.25	-15.42	33.83	46.00	-12.17	QP
5		400.4319	37.26	-11.08	26.18	46.00	-19.82	QP
6		558.7302	36.79	-7.48	29.31	46.00	-16.69	QP

Temperature :	26 °C	Relative Humidity :	54%
Pressure :	101kPa	Polarization :	Vertical
Test Voltage :	AC 120V/60Hz	Test Mode :	Mode 5

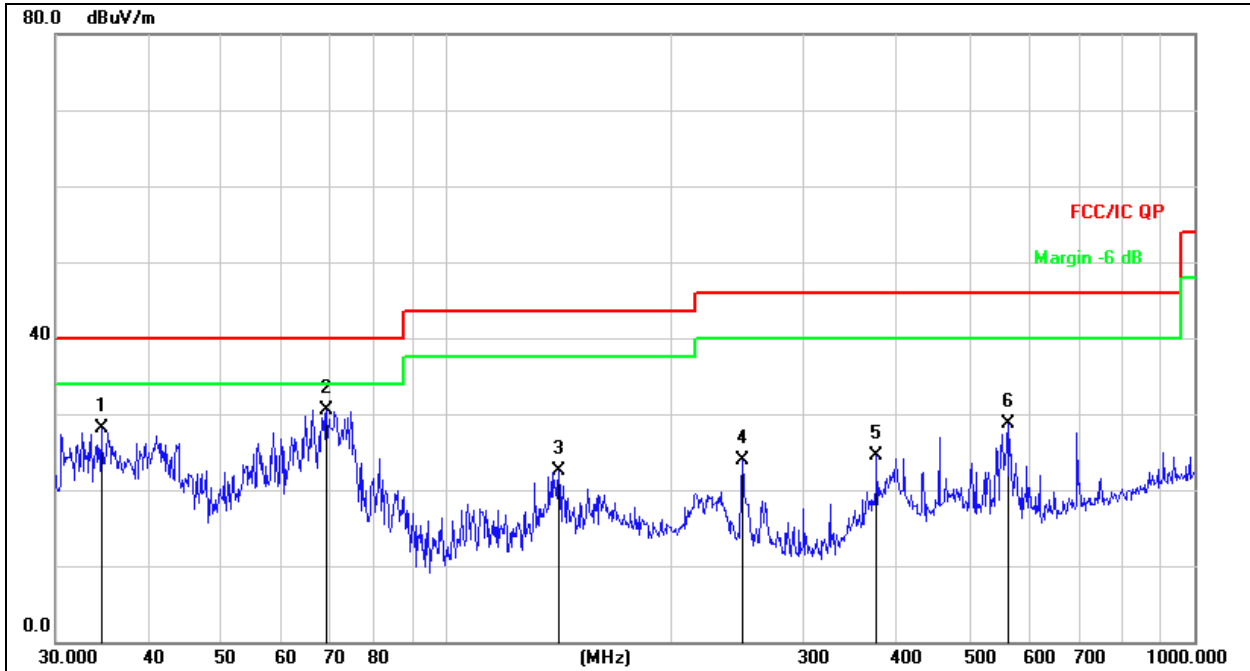

Remark:  
Factor = Antenna Factor + Cable Loss – Pre-amplifier.

No.	Mk.	Freq. MHz	Reading Level dBuV	Correct Factor dB	Measure- ment dBuV/m	Limit dB/m	Over dB	Detector
1		34.5173	44.64	-16.44	28.20	40.00	-11.80	QP
2	*	69.1141	48.57	-17.99	30.58	40.00	-9.42	QP
3		141.3298	41.42	-18.94	22.48	43.50	-21.02	QP
4		248.5519	39.10	-15.18	23.92	46.00	-22.08	QP
5		375.9385	36.11	-11.64	24.47	46.00	-21.53	QP
6		562.6624	36.10	-7.39	28.71	46.00	-17.29	QP

**4.2.8 TEST RESULTS**

Between 1GHz – 25GHz

**802.11b**

Polar (H/V)	Frequency	Reading Level	Correct Factor	Measure- ment	Limits	Over	Detector Type
	(MHz)	(dBuV/m)	(dB)	(dBuV/m)	(dBuV/ m)	(dB)	
<b>Low channel:2412MHz</b>							
V	4824.00	52.54	-0.43	52.11	74.00	-21.89	PK
V	4824.00	42.30	-0.43	41.87	54.00	-12.13	AV
V	7236.00	44.56	8.31	52.87	74.00	-21.13	PK
V	7236.00	34.23	8.31	42.54	54.00	-11.46	AV
H	4804.00	50.99	-0.43	50.56	74.00	-23.44	PK
H	4804.00	40.16	-0.43	39.73	54.00	-14.27	AV
H	7236.00	42.35	8.31	50.66	74.00	-23.34	PK
H	7236.00	33.84	8.31	42.15	54.00	-11.85	AV
<b>Middle channel:2437MHz</b>							
V	4874.00	50.54	-0.38	50.16	74.00	-23.84	PK
V	4874.00	42.00	-0.38	41.62	54.00	-12.38	AV
V	7311.00	41.18	8.83	50.01	74.00	-23.99	PK
V	7311.00	31.36	8.83	40.19	54.00	-13.81	AV
H	4874.00	46.06	-0.38	45.68	74.00	-28.32	PK
H	4874.00	36.62	-0.38	36.24	54.00	-17.76	AV
H	7311.00	38.86	8.83	47.69	74.00	-26.31	PK
H	7311.00	30.56	8.83	39.39	54.00	-14.61	AV
<b>High channel:2462MHz</b>							
V	4924.00	52.18	-0.32	51.86	74.00	-22.14	PK
V	4924.00	42.69	-0.32	42.37	54.00	-11.63	AV
V	7386.00	45.00	9.35	54.35	74.00	-19.65	PK
V	7386.00	35.14	9.35	44.49	54.00	-9.51	AV
H	4924.00	51.07	-0.32	50.75	74.00	-23.25	PK
H	4924.00	41.12	-0.32	40.80	54.00	-13.20	AV
H	7386.00	42.57	9.35	51.92	74.00	-22.08	PK
H	7386.00	34.46	9.35	43.81	54.00	-10.19	AV

Remark:

1. Emission Level = Meter Reading + Factor,

Factor = Antenna Factor + Cable Loss – Pre-amplifier.

Over = Emission Level - Limit

2. If peak below the average limit, the average emission was no test.

3. In restricted bands of operation, The spurious emissions below the permissible value more than 20dB

4. The amplitude of spurious emissions which are attenuated by more than 20dB below the permissible value has no need to be reported.



**802.11g**

Polar (H/V)	Frequency	Reading Level	Correct Factor	Measurement	Limits	Over	Detector Type
	(MHz)	(dBuV/m)	(dB)	(dBuV/m)	(dBuV/m)	(dB)	
<b>Low channel:2412MHz</b>							
V	4824.00	52.42	-0.43	51.99	74.00	-22.01	PK
V	4824.00	42.61	-0.43	42.18	54.00	-11.82	AV
V	7236.00	45.20	8.31	53.51	74.00	-20.49	PK
V	7236.00	35.31	8.31	43.62	54.00	-10.38	AV
H	4804.00	49.41	-0.43	48.98	74.00	-25.02	PK
H	4804.00	38.97	-0.43	38.54	54.00	-15.46	AV
H	7236.00	42.63	8.31	50.94	74.00	-23.06	PK
H	7236.00	34.34	8.31	42.65	54.00	-11.35	AV
<b>Middle channel:2437MHz</b>							
V	4874.00	49.99	-0.38	49.61	74.00	-24.39	PK
V	4874.00	42.01	-0.38	41.63	54.00	-12.37	AV
V	7311.00	39.86	8.83	48.69	74.00	-25.31	PK
V	7311.00	30.24	8.83	39.07	54.00	-14.93	AV
H	4874.00	45.69	-0.38	45.31	74.00	-28.69	PK
H	4874.00	35.04	-0.38	34.66	54.00	-19.34	AV
H	7311.00	38.54	8.83	47.37	74.00	-26.63	PK
H	7311.00	30.37	8.83	39.20	54.00	-14.80	AV
<b>High channel:2462MHz</b>							
V	4924.00	51.54	-0.32	51.22	74.00	-22.78	PK
V	4924.00	43.53	-0.32	43.21	54.00	-10.79	AV
V	7386.00	42.90	9.35	52.25	74.00	-21.75	PK
V	7386.00	32.48	9.35	41.83	54.00	-12.17	AV
H	4924.00	49.35	-0.32	49.03	74.00	-24.97	PK
H	4924.00	39.47	-0.32	39.15	54.00	-14.85	AV
H	7386.00	41.76	9.35	51.11	74.00	-22.89	PK
H	7386.00	34.02	9.35	43.37	54.00	-10.63	AV

**Remark:**

1. Emission Level = Meter Reading + Factor,

Factor = Antenna Factor + Cable Loss – Pre-amplifier.

Over = Emission Level - Limit

2. If peak below the average limit, the average emission was no test.

3. In restricted bands of operation, The spurious emissions below the permissible value more than 20dB

4. The amplitude of spurious emissions which are attenuated by more than 20dB below the permissible value has no need to be reported.

**802.11n20**

Polar (H/V)	Frequency	Reading Level	Correct Factor	Measure- ment	Limits	Over	Detector Type
	(MHz)	(dBuV/m)	(dB)	(dBuV/m)	(dBuV/ m)	(dB)	
<b>Low channel:2412MHz</b>							
V	4824.00	54.22	-0.43	53.79	74.00	-20.21	PK
V	4824.00	45.08	-0.43	44.65	54.00	-9.35	AV
V	7236.00	43.63	8.31	51.94	74.00	-22.06	PK
V	7236.00	33.24	8.31	41.55	54.00	-12.45	AV
H	4804.00	51.73	-0.43	51.30	74.00	-22.70	PK
H	4804.00	40.99	-0.43	40.56	54.00	-13.44	AV
H	7236.00	42.05	8.31	50.36	74.00	-23.64	PK
H	7236.00	34.79	8.31	43.10	54.00	-10.90	AV
<b>Middle channel:2437MHz</b>							
V	4874.00	51.29	-0.38	50.91	74.00	-23.09	PK
V	4874.00	42.86	-0.38	42.48	54.00	-11.52	AV
V	7311.00	44.15	8.83	52.98	74.00	-21.02	PK
V	7311.00	34.91	8.83	43.74	54.00	-10.26	AV
H	4874.00	48.64	-0.38	48.26	74.00	-25.74	PK
H	4874.00	38.15	-0.38	37.77	54.00	-16.23	AV
H	7311.00	42.73	8.83	51.56	74.00	-22.44	PK
H	7311.00	33.78	8.83	42.61	54.00	-11.39	AV
<b>High channel:2462MHz</b>							
V	4924.00	52.74	-0.32	52.42	74.00	-21.58	PK
V	4924.00	43.68	-0.32	43.36	54.00	-10.64	AV
V	7386.00	46.18	9.35	55.53	74.00	-18.47	PK
V	7386.00	36.33	9.35	45.68	54.00	-8.32	AV
H	4924.00	49.80	-0.32	49.48	74.00	-24.52	PK
H	4924.00	39.85	-0.32	39.53	54.00	-14.47	AV
H	7386.00	44.22	9.35	53.57	74.00	-20.43	PK
H	7386.00	35.79	9.35	45.14	54.00	-8.86	AV

**Remark:**

1. Emission Level = Meter Reading + Factor,

Factor = Antenna Factor + Cable Loss – Pre-amplifier.

Over= Emission Level - Limit

2. If peak below the average limit, the average emission was no test.

3. In restricted bands of operation, The spurious emissions below the permissible value more than 20dB

4. The amplitude of spurious emissions which are attenuated by more than 20dB below the permissible value has no need to be reported.

**802.11n40**

Polar (H/V)	Frequency	Reading Level	Correct Factor	Measure- ment	Limits	Over	Detector Type
	(MHz)	(dBuV/m)	(dB)	(dBuV/m)	(dBuV/ m)	(dB)	
<b>Low channel:2422MHz</b>							
V	4844.00	52.34	-0.43	51.91	74.00	-22.09	PK
V	4844.00	43.22	-0.43	42.79	54.00	-11.21	AV
V	7266.00	42.17	8.31	50.48	74.00	-23.52	PK
V	7266.00	32.32	8.31	40.63	54.00	-13.37	AV
H	4844.00	47.61	-0.43	47.18	74.00	-26.82	PK
H	4844.00	37.82	-0.43	37.39	54.00	-16.61	AV
H	7266.00	40.90	8.31	49.21	74.00	-24.79	PK
H	7266.00	32.81	8.31	41.12	54.00	-12.88	AV
<b>Middle channel:2437MHz</b>							
V	4874.00	48.94	-0.38	48.56	74.00	-25.44	PK
V	4874.00	40.86	-0.38	40.48	54.00	-13.52	AV
V	7311.00	41.50	8.83	50.33	74.00	-23.67	PK
V	7311.00	31.60	8.83	40.43	54.00	-13.57	AV
H	4874.00	44.03	-0.38	43.65	74.00	-30.35	PK
H	4874.00	33.34	-0.38	32.96	54.00	-21.04	AV
H	7311.00	39.87	8.83	48.70	74.00	-25.30	PK
H	7311.00	32.22	8.83	41.05	54.00	-12.95	AV
<b>High channel:2452MHz</b>							
V	4904.00	50.21	-0.32	49.89	74.00	-24.11	PK
V	4904.00	40.52	-0.32	40.20	54.00	-13.80	AV
V	7356.00	43.83	9.35	53.18	74.00	-20.82	PK
V	7356.00	34.02	9.35	43.37	54.00	-10.63	AV
H	4904.00	47.39	-0.32	47.07	74.00	-26.93	PK
H	4904.00	38.31	-0.32	37.99	54.00	-16.01	AV
H	7356.00	41.90	9.35	51.25	74.00	-22.75	PK
H	7356.00	34.45	9.35	43.80	54.00	-10.20	AV

**Remark:**

1. Emission Level = Meter Reading + Factor,

Factor = Antenna Factor + Cable Loss – Pre-amplifier.

Over = Emission Level - Limit

2. If peak below the average limit, the average emission was no test.

3. In restricted bands of operation, The spurious emissions below the permissible value more than 20dB

4. The amplitude of spurious emissions which are attenuated by more than 20dB below the permissible value has no need to be reported.

Note: A(B) Represent the value of antenna A and B, The worst data is Antenna A, only shown Antenna A data recording in the report.

MIMO

**802.11n20**

Polar (H/V)	Frequency	Reading Level	Correct Factor	Measure- ment	Limits	Over	Detector Type
	(MHz)	(dBuV/m)	(dB)	(dBuV/m)	(dBuV/ m)	(dB)	
<b>Low channel:2412MHz</b>							
V	4824.00	53.47	-0.43	53.04	74.00	-20.96	PK
V	4824.00	44.64	-0.43	44.21	54.00	-9.79	AV
V	7236.00	44.46	8.31	52.77	74.00	-21.23	PK
V	7236.00	34.30	8.31	42.61	54.00	-11.39	AV
H	4804.00	51.24	-0.43	50.81	74.00	-23.19	PK
H	4804.00	40.48	-0.43	40.05	54.00	-13.95	AV
H	7236.00	42.14	8.31	50.45	74.00	-23.55	PK
H	7236.00	33.87	8.31	42.18	54.00	-11.82	AV
<b>Middle channel:2437MHz</b>							
V	4874.00	50.31	-0.38	49.93	74.00	-24.07	PK
V	4874.00	42.37	-0.38	41.99	54.00	-12.01	AV
V	7311.00	40.74	8.83	49.57	74.00	-24.43	PK
V	7311.00	31.98	8.83	40.81	54.00	-13.19	AV
H	4874.00	45.79	-0.38	45.41	74.00	-28.59	PK
H	4874.00	35.03	-0.38	34.65	54.00	-19.35	AV
H	7311.00	37.84	8.83	46.67	74.00	-27.33	PK
H	7311.00	29.69	8.83	38.52	54.00	-15.48	AV
<b>High channel:2462MHz</b>							
V	4924.00	51.74	-0.32	51.42	74.00	-22.58	PK
V	4924.00	42.49	-0.32	42.17	54.00	-11.83	AV
V	7386.00	44.11	9.35	53.46	74.00	-20.54	PK
V	7386.00	33.87	9.35	43.22	54.00	-10.78	AV
H	4924.00	49.11	-0.32	48.79	74.00	-25.21	PK
H	4924.00	38.95	-0.32	38.63	54.00	-15.37	AV
H	7386.00	42.59	9.35	51.94	74.00	-22.06	PK
H	7386.00	34.84	9.35	44.19	54.00	-9.81	AV

Remark:

1. Emission Level = Meter Reading + Factor,

Factor = Antenna Factor + Cable Loss – Pre-amplifier.

Over = Emission Level - Limit

2. If peak below the average limit, the average emission was no test.

3. In restricted bands of operation, The spurious emissions below the permissible value more than 20dB

4. The amplitude of spurious emissions which are attenuated by more than 20dB below the permissible value has no need to be reported.

**802.11n40**

Polar (H/V)	Frequency	Reading Level	Correct Factor	Measure- ment	Limits	Over	Detector Type
	(MHz)	(dBuV/m)	(dB)	(dBuV/m)	(dBuV/ m)	(dB)	
<b>Low channel:2422MHz</b>							
V	4844.00	54.80	-0.43	54.37	74.00	-19.63	PK
V	4844.00	44.43	-0.43	44.00	54.00	-10.00	AV
V	7266.00	45.40	8.31	53.71	74.00	-20.29	PK
V	7266.00	34.72	8.31	43.03	54.00	-10.97	AV
H	4844.00	50.70	-0.43	50.27	74.00	-23.73	PK
H	4844.00	40.81	-0.43	40.38	54.00	-13.62	AV
H	7266.00	42.62	8.31	50.93	74.00	-23.07	PK
H	7266.00	35.53	8.31	43.84	54.00	-10.16	AV
<b>Middle channel:2437MHz</b>							
V	4874.00	52.93	-0.38	52.55	74.00	-21.45	PK
V	4874.00	44.71	-0.38	44.33	54.00	-9.67	AV
V	7311.00	42.31	8.83	51.14	74.00	-22.86	PK
V	7311.00	33.76	8.83	42.59	54.00	-11.41	AV
H	4874.00	50.07	-0.38	49.69	74.00	-24.31	PK
H	4874.00	39.25	-0.38	38.87	54.00	-15.13	AV
H	7311.00	40.51	8.83	49.34	74.00	-24.66	PK
H	7311.00	32.80	8.83	41.63	54.00	-12.37	AV
<b>High channel:2452MHz</b>							
V	4904.00	54.50	-0.32	54.18	74.00	-19.82	PK
V	4904.00	44.68	-0.32	44.36	54.00	-9.64	AV
V	7356.00	48.40	9.35	57.75	74.00	-16.25	PK
V	7356.00	38.11	9.35	47.46	54.00	-6.54	AV
H	4904.00	52.96	-0.32	52.64	74.00	-21.36	PK
H	4904.00	42.12	-0.32	41.80	54.00	-12.20	AV
H	7356.00	45.41	9.35	54.76	74.00	-19.24	PK
H	7356.00	38.01	9.35	47.36	54.00	-6.64	AV

Remark:

1. Emission Level = Meter Reading + Factor,

Factor = Antenna Factor + Cable Loss – Pre-amplifier.

Over = Emission Level - Limit

2. If peak below the average limit, the average emission was no test.

3. In restricted bands of operation, The spurious emissions below the permissible value more than 20dB

4. The amplitude of spurious emissions which are attenuated by more than 20dB below the permissible value has no need to be reported.

### 4.3 RADIATED BAND EMISSION MEASUREMENT

#### 4.3.1 TEST REQUIREMENT:

FCC Part15 C Section 15.209 and 15.205

(a) Except as shown in paragraph (d) of this section, only spurious emissions are permitted in any of the frequency bands listed below:

MHz	MHz	MHz	GHz
0.090-0.110	16.42-16.423	399.9-410	4.5-5.15
0.495-0.505	16.69475-16.69525	608-614	5.35-5.46
2.1735-2.1905	16.80425-16.80475	960-1240	7.25-7.75
4.125-4.128	25.5-25.67	1300-1427	8.025-8.5
4.17725-4.17775	37.5-38.25	1435-1626.5	9.0-9.2
4.20725-4.20775	73-74.6	1645.5-1646.5	9.3-9.5
6.215-6.218	74.8-75.2	1660-1710	10.6-12.7
6.26775-6.26825	108-121.94	1718.8-1722.2	13.25-13.4
6.31175-6.31225	123-138	2200-2300	14.47-14.5
8.291-8.294	149.9-150.05	2310-2390	15.35-16.2
8.362-8.366	156.52475-156.52525	2483.5-2500	17.7-21.4
8.37625-8.38675	156.7-156.9	2690-2900	22.01-23.12
8.41425-8.41475	162.0125-167.17	3260-3267	23.6-24.0
12.29-12.293	167.72-173.2	3332-3339	31.2-31.8
12.51975-12.52025	240-285	3345.8-3358	36.43-36.5
12.57675-12.57725	322-335.4	3600-4400	(c)
13.36-13.41			

#### LIMITS OF RADIATED EMISSION MEASUREMENT (Above 1000MHz)

FREQUENCY (MHz)	Class B (dBuV/m) (at 3M)	
	PEAK	AVERAGE
Above 1000	74	54

Notes:

- (1) The limit for radiated test was performed according to FCC PART 15C.
- (2) The tighter limit applies at the band edges.
- (3) Emission level (dBuV/m)=20log Emission level (uV/m).

Spectrum Parameter	Setting
Attenuation	Auto
Start Frequency	2300MHz
Stop Frequency	2520
RB / VB (emission in restricted band)	1 MHz / 1 MHz for Peak, 1 MHz / 10Hz for Average

#### 4.3.2 TEST PROCEDURE

Above 1GHz test procedure as below:

- a. 1. The EUT was placed on the top of a rotating table 1.5 meters above the ground at a 3 meter camber. The table was rotated 360 degrees to determine the position of the highest radiation.
- b. The EUT was set 3 meters away from the interference-receiving antenna, which was mounted on the top of a variable-height antenna tower.
- c. The antenna height is varied from one meter to four meters above the ground to determine the maximum value of the field strength. Both horizontal and vertical polarizations of the antenna are set to make the measurement.
- d. For each suspected emission, the EUT was arranged to its worst case and then the antenna was tuned to heights from 1 meter to 4 meters and the rota table was turned from 0 degrees to 360 degrees to find the maximum reading.

- e. The test-receiver system was set to Peak Detect Function and Specified Bandwidth with Maximum Hold Mode.
- f. If the emission level of the EUT in peak mode was 10dB lower than the limit specified, then testing could be stopped and the peak values of the EUT would be reported. Otherwise the emissions that did not have 10dB margin would be re-tested one by one using peak, quasi-peak or average method as specified and then reported in a data sheet.
- g. Test the EUT in the lowest channel, the Highest channel

Note:

Both horizontal and vertical antenna polarities were tested and performed pretest to three orthogonal axis. The worst case emissions were reported

#### 4.3.3 DEVIATION FROM TEST STANDARD

No deviation

#### 4.3.4 TEST SETUP

Radiated Emission Test-Up Frequency Above 1GHz

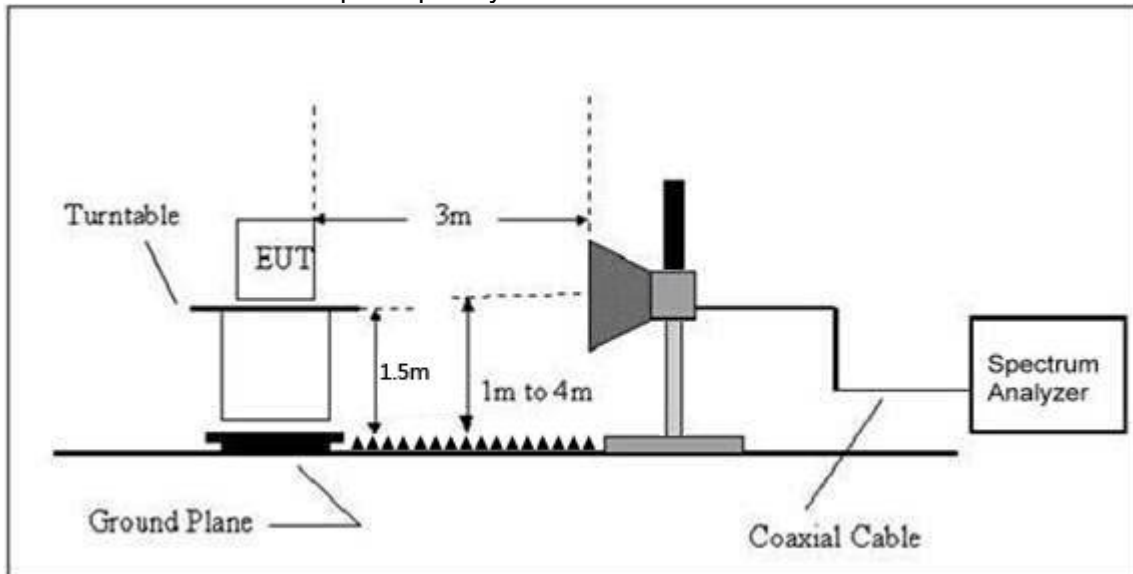

#### 4.3.5 EUT OPERATING CONDITIONS

The EUT tested system was configured as the statements of 2.3 Unless otherwise a special operating condition is specified in the follows during the testing.

**4.3.6 TEST RESULT**

	Polar (H/V)	Frequency (MHz)	Reading Level (dBuV/m)	Correct Factor (dB)	Measurement (dBuV/m)	Limits (dBuV/m)		Result	
					PK	PK	AV		
<b>802.11b</b>	<b>Low Channel 2412MHz</b>								
	H	2390.00	57.32	-6.70	50.62	74.00	54.00	PASS	
	H	2400.00	48.84	-6.71	42.13	74.00	54.00	PASS	
	V	2390.00	57.37	-6.70	50.67	74.00	54.00	PASS	
	V	2400.00	49.03	-6.71	42.32	74.00	54.00	PASS	
	<b>High Channel 2462MHz</b>								
	H	2483.50	56.68	-6.79	49.89	74.00	54.00	PASS	
	H	2485.00	48.77	-6.81	41.96	74.00	54.00	PASS	
	V	2483.50	55.87	-6.79	49.08	74.00	54.00	PASS	
	V	2485.00	48.27	-6.81	41.46	74.00	54.00	PASS	
	<b>802.11g</b>	<b>Low Channel 2412MHz</b>							
		H	2390.00	57.63	-6.70	50.93	74.00	54.00	PASS
H		2400.00	50.24	-6.71	43.53	74.00	54.00	PASS	
V		2390.00	56.99	-6.70	50.29	74.00	54.00	PASS	
V		2400.00	49.16	-6.71	42.45	74.00	54.00	PASS	
<b>High Channel 2462MHz</b>									
H		2483.50	55.79	-6.79	49.00	74.00	54.00	PASS	
H		2485.00	49.40	-6.81	42.59	74.00	54.00	PASS	
V		2483.50	57.21	-6.79	50.42	74.00	54.00	PASS	
V		2485.00	49.20	-6.81	42.39	74.00	54.00	PASS	

**Remark:**

1. Emission Level = Meter Reading + Factor,  
Factor = Antenna Factor + Cable Loss – Pre-amplifier.  
Over= Emission Level - Limit
2. If the PK measured levels comply with average limit, then the average level were deemed to comply with average limit.
- 3 In restricted bands of operation, The spurious emissions below the permissible value more than 20dB
4. The amplitude of spurious emissions which are attenuated by more than 20dB below the permissible value has no need to be reported.

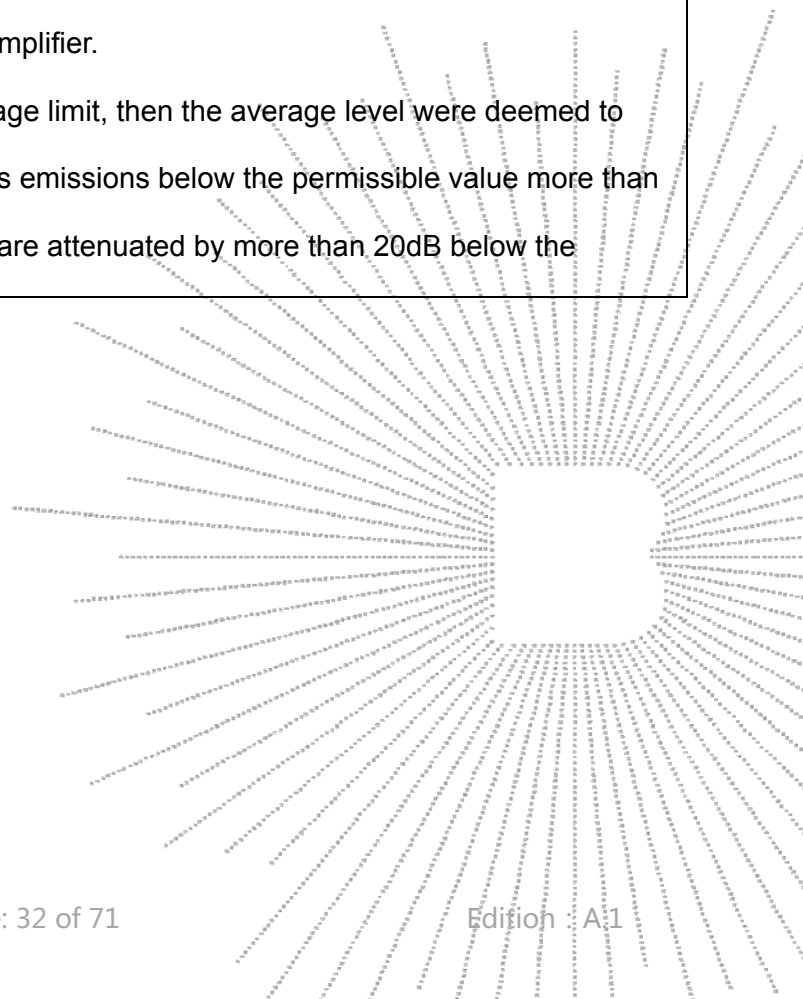



	Polar (H/V)	Frequency (MHz)	Reading Level (dBuV/m)	Correct Factor (dB)	Measurement (dBuV/m)	Limits (dBuV/m)		Result
					PK	PK	AV	
<b>802.11 n20</b>	<b>Low Channel 2412MHz</b>							
	H	2390.00	56.38	-6.70	49.68	74.00	54.00	PASS
	H	2400.00	48.64	-6.71	41.93	74.00	54.00	PASS
	V	2390.00	55.64	-6.70	48.94	74.00	54.00	PASS
	V	2400.00	47.51	-6.71	40.80	74.00	54.00	PASS
	<b>High Channel 2462MHz</b>							
	H	2483.50	55.76	-6.79	48.97	74.00	54.00	PASS
	H	2500.00	48.73	-6.81	41.92	74.00	54.00	PASS
	V	2483.50	53.74	-6.79	46.95	74.00	54.00	PASS
	V	2500.00	44.89	-6.81	38.08	74.00	54.00	PASS
<b>802.11 n40</b>	<b>Low Channel 2422MHz</b>							
	H	2390.00	57.74	-6.70	51.04	74.00	54.00	PASS
	H	2400.00	49.59	-6.71	42.88	74.00	54.00	PASS
	V	2390.00	57.67	-6.70	50.97	74.00	54.00	PASS
	V	2400.00	50.57	-6.71	43.86	74.00	54.00	PASS
	<b>High Channel 2452MHz</b>							
	H	2483.50	55.95	-6.79	49.16	74.00	54.00	PASS
	H	2500.00	49.34	-6.81	42.53	74.00	54.00	PASS
	V	2483.50	56.27	-6.79	49.48	74.00	54.00	PASS
	V	2500.00	47.95	-6.81	41.14	74.00	54.00	PASS

**Remark:**

- Emission Level = Meter Reading + Factor,  
Factor = Antenna Factor + Cable Loss – Pre-amplifier.  
Over= Emission Level - Limit
- If the PK measured levels comply with average limit, then the average level were deemed to comply with average limit.
- In restricted bands of operation, The spurious emissions below the permissible value more than 20dB
- The amplitude of spurious emissions which are attenuated by more than 20dB below the permissible value has no need to be reported.

Note: A(B) Represent the value of antenna A and B, The worst data is Antenna A, only shown Antenna A data recording in the report.

MIMO

	Polar (H/V)	Frequency (MHz)	Reading Level (dBuV/m)	Correct Factor (dB)	Measurement (dBuV/m)	Limits (dBuV/m)		Result
					PK	PK	AV	
802.11 n20	<b>Low Channel 2412MHz</b>							
	H	2390.00	56.23	-6.70	49.53	74.00	54.00	PASS
	H	2400.00	48.51	-6.71	41.80	74.00	54.00	PASS
	V	2390.00	56.32	-6.70	49.62	74.00	54.00	PASS
	V	2400.00	47.35	-6.71	40.64	74.00	54.00	PASS
	<b>High Channel 2462MHz</b>							
	H	2483.50	55.67	-6.79	48.88	74.00	54.00	PASS
	H	2500.00	47.30	-6.81	40.49	74.00	54.00	PASS
	V	2483.50	55.36	-6.79	48.57	74.00	54.00	PASS
	V	2500.00	47.00	-6.81	40.19	74.00	54.00	PASS
802.11 n40	<b>Low Channel 2422MHz</b>							
	H	2390.00	57.54	-6.70	50.84	74.00	54.00	PASS
	H	2400.00	49.73	-6.71	43.02	74.00	54.00	PASS
	V	2390.00	58.06	-6.70	51.36	74.00	54.00	PASS
	V	2400.00	50.83	-6.71	44.12	74.00	54.00	PASS
	<b>High Channel 2452MHz</b>							
	H	2483.50	56.32	-6.79	49.53	74.00	54.00	PASS
	H	2500.00	49.18	-6.81	42.37	74.00	54.00	PASS
	V	2483.50	56.84	-6.79	50.05	74.00	54.00	PASS
	V	2500.00	49.46	-6.81	42.65	74.00	54.00	PASS

**Remark:**

- Emission Level = Meter Reading + Factor,  
Factor = Antenna Factor + Cable Loss – Pre-amplifier.  
Over= Emission Level - Limit
- If the PK measured levels comply with average limit, then the average level were deemed to comply with average limit.
- In restricted bands of operation, The spurious emissions below the permissible value more than 20dB
- The amplitude of spurious emissions which are attenuated by more than 20dB below the permissible value has no need to be reported.

## 5. POWER SPECTRAL DENSITY TEST

### 5.1 APPLIED PROCEDURES / LIMIT

FCC Part15 (15.247) , Subpart C				
Section	Test Item	Limit	Frequency Range (MHz)	Result
15.247	Power Spectral Density	8 dBm (in any 3KHz)	2400-2483.5	PASS

#### 5.1.1 TEST PROCEDURE

1. Set analyzer center frequency to DTS channel center frequency.
2. Set the span to 1.5 times the DTS bandwidth.
3. Set the RBW to:  $3 \text{ kHz} \leq \text{RBW} \leq 100 \text{ kHz}$ .
4. Set the VBW  $\geq 3 \times \text{RBW}$ .
5. Detector = peak.
6. Sweep time = auto couple.
7. Trace mode = max hold.
8. Allow trace to fully stabilize.
9. Use the peak marker function to determine the maximum amplitude level within the RBW.
10. If measured value exceeds limit, reduce RBW (no less than 3 kHz) and repeat.

#### 5.1.2 DEVIATION FROM STANDARD

No deviation.

#### 5.1.3 TEST SETUP

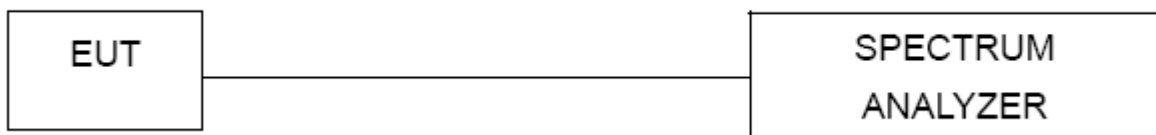

#### 5.1.4 EUT OPERATION CONDITIONS

The EUT tested system was configured as the statements of 2.1 Unless otherwise a special operating condition is specified in the follows during the testing.

Note: Power Spectral Density(dBm)=Reading+Cable Loss

#### 5.1.5 TEST RESULTS

Temperature :	26 °C	Relative Humidity :	54%
Pressure :	101kPa	Test Voltage :	AC120V/60Hz
Test Mode :	TX b Mode		

Frequency	Power Spectral Density (dBm/3KHz) ANTA	Power Spectral Density (dBm/3KHz) ANTB	Total power density (dBm/3KHz)	Limit (dBm/3KHz)	Result
2412 MHz	-11.106	-10.267	/	8	PASS
2437 MHz	-10.443	-10.241	/	8	PASS
2462 MHz	-10.985	-10.540	/	8	PASS

Note: A(B) Represent the value of antenna A and B, The worst data is Antenna B, only shown Antenna B Plot.

### TX CH01



**TX CH06**



**TX CH11**



Temperature :	26 °C	Relative Humidity :	54%
Pressure :	101kPa	Test Voltage :	AC120V/60Hz
Test Mode :	TX g Mode		

Frequency	Power Spectral Density (dBm/3KHz) ANTA	Power Spectral Density (dBm/3KHz) ANTB	Total power density (dBm/3KHz)	Limit (dBm/3KHz)	Result
2412 MHz	-16.406	-16.513	/	8	PASS
2437 MHz	-16.099	-15.509	/	8	PASS
2462 MHz	-15.730	-15.451	/	8	PASS

Note: A(B) Represent the value of antenna A and B, The worst data is Antenna B, only shown Antenna B Plot.

### TX CH01

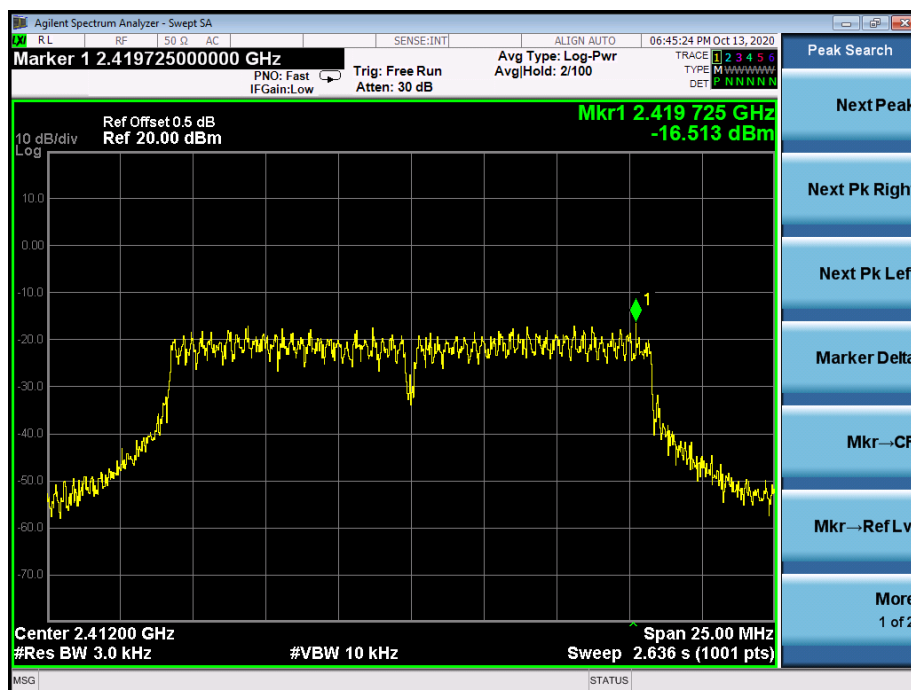

**TX CH06**

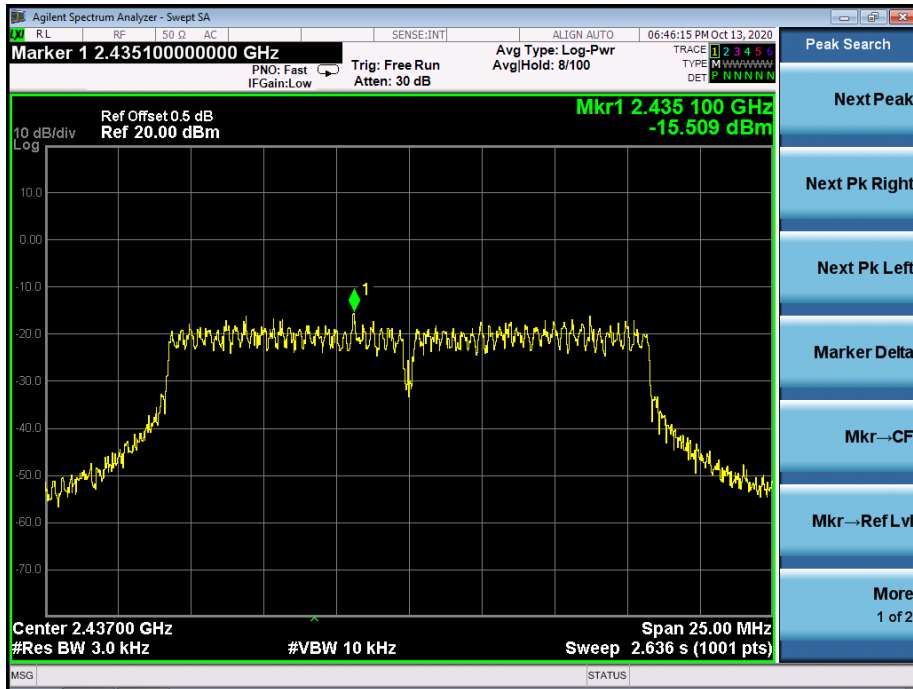

**TX CH11**

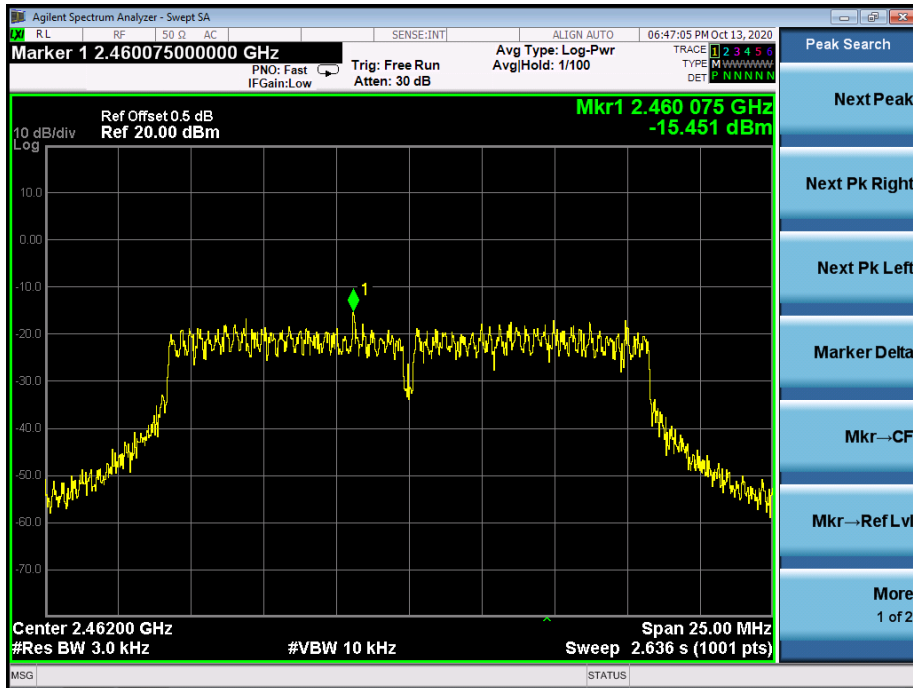

Temperature :	26 °C	Relative Humidity :	54%
Pressure :	101kPa	Test Voltage :	AC120V/60Hz
Test Mode :	TX n Mode(20M)		

Frequency	Power Spectral Density (dBm/3KHz) ANTA	Power Spectral Density (dBm/3KHz) ANTB	Total power density (dBm/3KHz)	Limit (dBm/3KHz)	Result
2412 MHz	-16.277	-17.072	-13.65	8	PASS
2437 MHz	-16.418	-15.889	-13.14	8	PASS
2462 MHz	-14.959	-14.894	-11.92	8	PASS

Note: A(B) Represent the value of antenna A and B, The worst data is Antenna A ,only shown Antenna A Plot.

### TX CH01

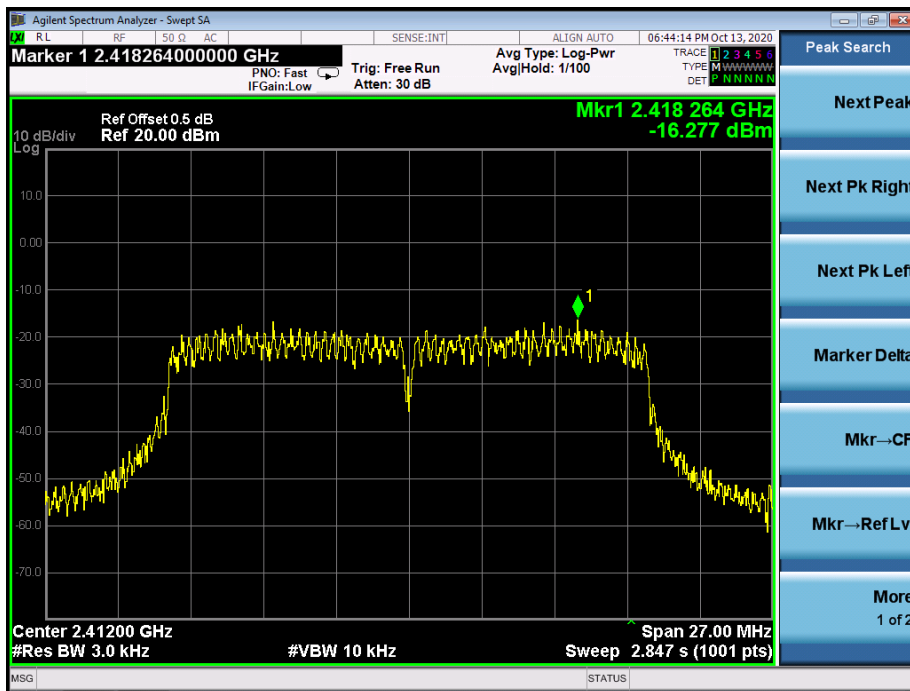



**TX CH06**

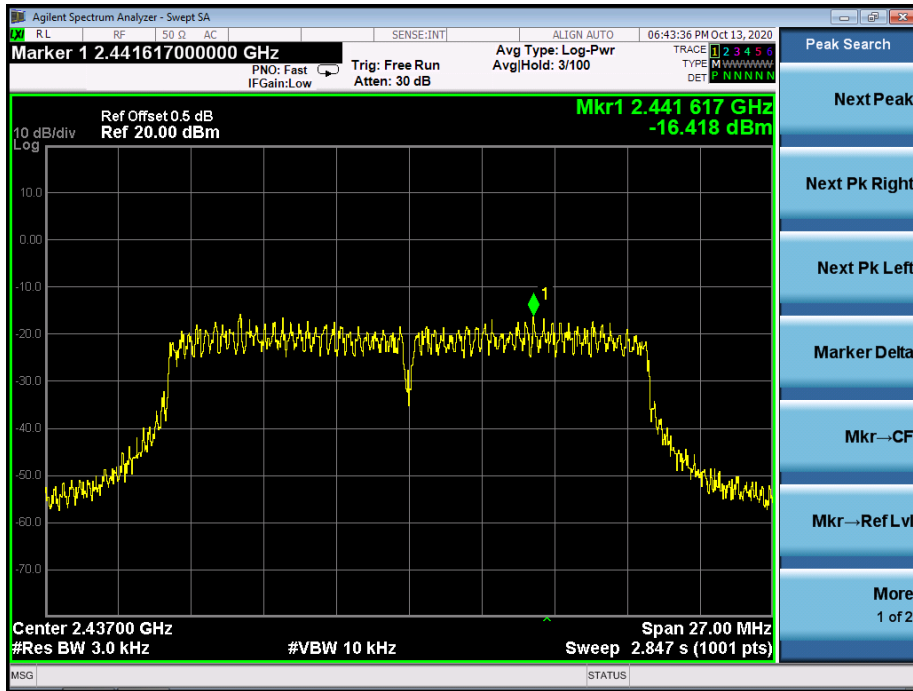

**TX CH11**

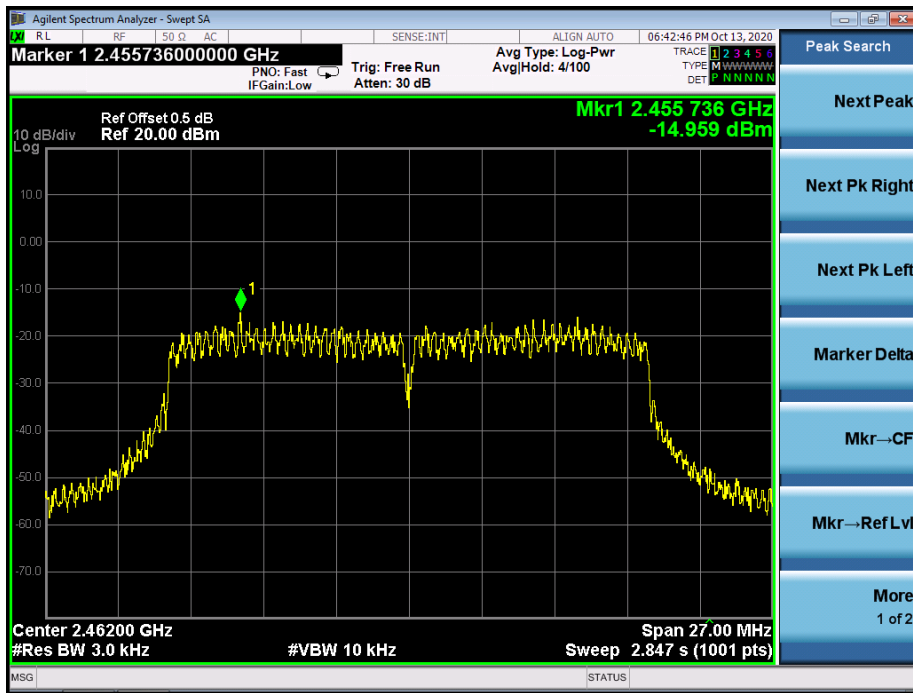

Temperature :	26 °C	Relative Humidity :	54%
Pressure :	101kPa	Test Voltage :	AC120V/60Hz
Test Mode :	TX n Mode(40M)		

Frequency	Power Spectral Density (dBm/3KHz) ANTA	Power Spectral Density (dBm/3KHz) ANTB	Total power density (dBm/3KHz)	Limit (dBm/3KHz)	Result
2422 MHz	-17.469	-17.497	-14.47	8	PASS
2437 MHz	-17.187	-18.153	-14.63	8	PASS
2452 MHz	-18.003	-16.953	-14.44	8	PASS

Note: A(B) Represent the value of antenna A and B, The worst data is Antenna A ,only shown Antenna A Plot.

**TX CH03**

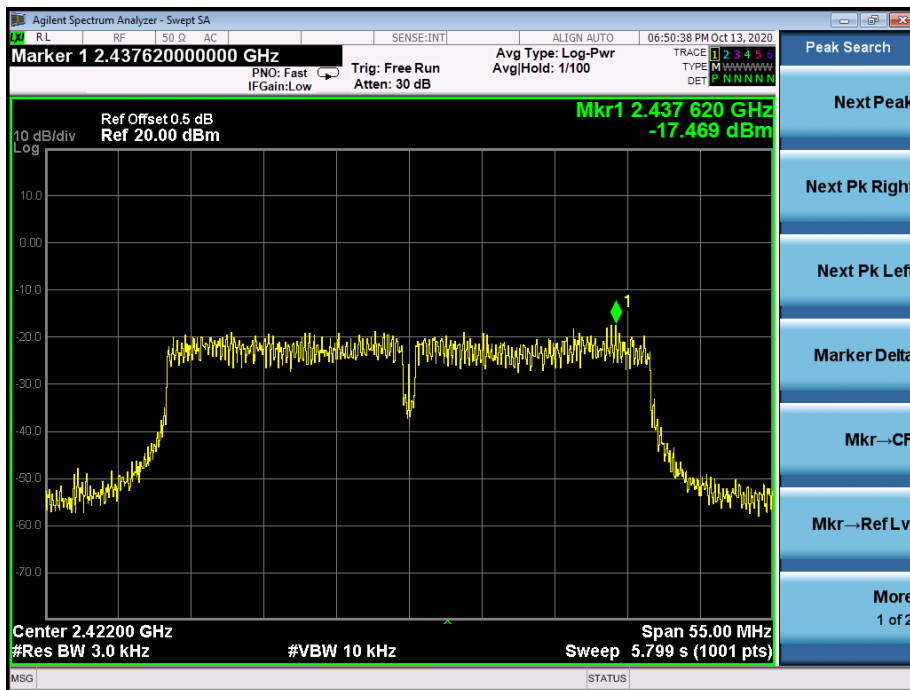

**TX CH06**

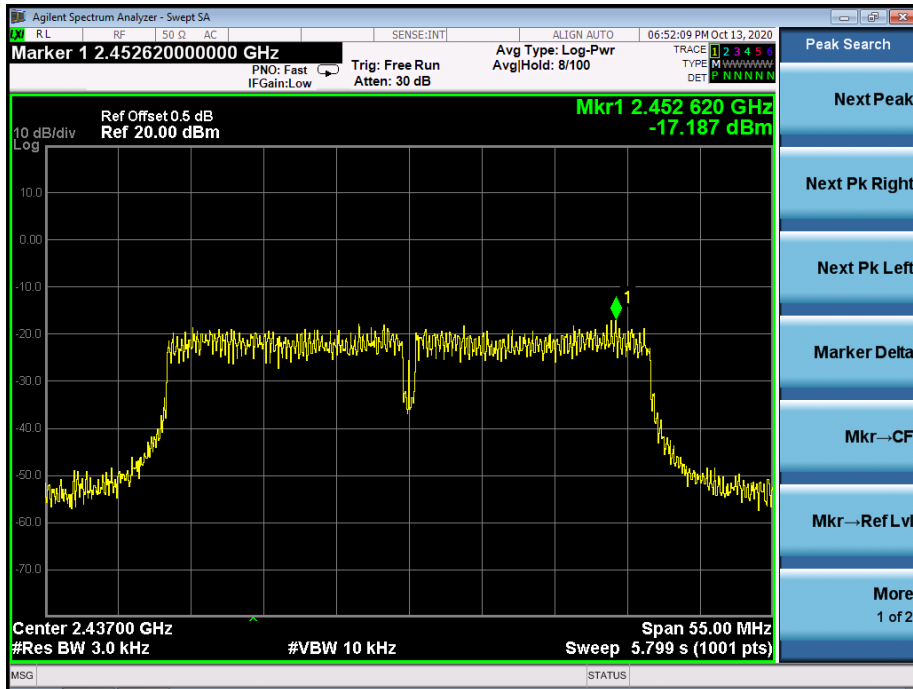

**TX CH09**

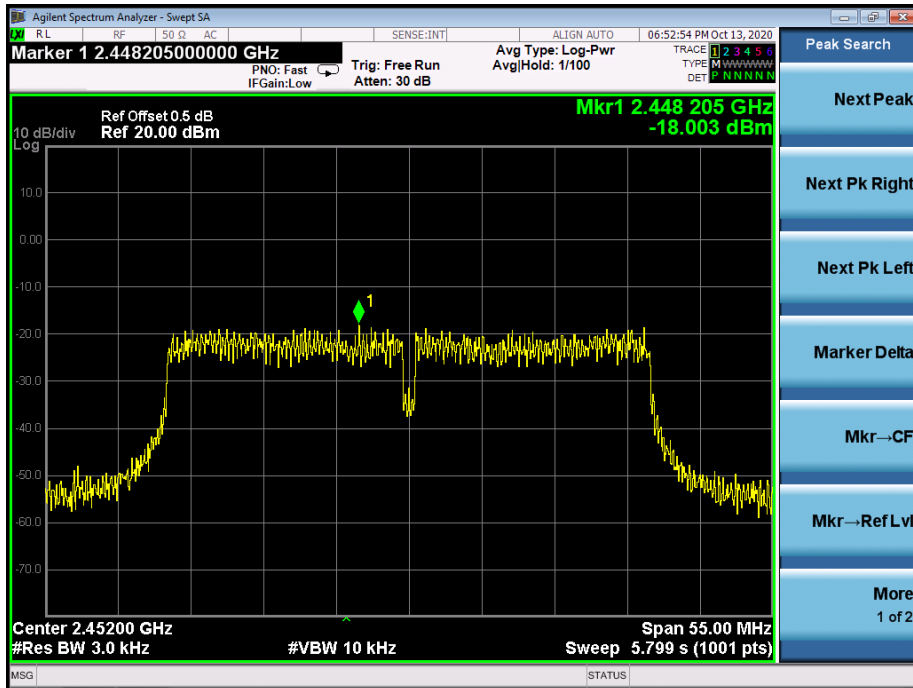

## 6. BANDWIDTH TEST

### 6.1 APPLIED PROCEDURES / LIMIT

FCC Part15 (15.247) , Subpart C				
Section	Test Item	Limit	Frequency Range (MHz)	Result
15.247(a)(2)	Bandwidth	$\geq 500\text{KHz}$ (6dB bandwidth)	2400-2483.5	PASS

#### 6.1.1 TEST PROCEDURE

1. Set RBW = 100 kHz.
2. Set the video bandwidth (VBW)  $\geq 3 \times$  RBW.
3. Detector = Peak.
4. Trace mode = max hold.
5. Sweep = auto couple.
6. Allow the trace to stabilize.
7. Measure the maximum width of the emission that is constrained by the frequencies associated with the two outermost amplitude points (upper and lower frequencies) that are attenuated by 6 dB relative to the maximum level measured in the fundamental emission.

#### 6.1.2 DEVIATION FROM STANDARD

No deviation.

#### 6.1.3 TEST SETUP



#### 6.1.4 EUT OPERATION CONDITIONS

The EUT tested system was configured as the statements of 2.4 Unless otherwise a special operating condition is specified in the follows during the testing.

### 6.1.5 TEST RESULTS

Temperature :	26 °C	Relative Humidity :	54%
Pressure :	101kPa	Test Voltage :	AC120V/60Hz
Test Mode :	TX b Mode		

Frequency (MHz)	6dB bandwidth (MHz) ANTA	6dB bandwidth (MHz) ANTB	Limit (kHz)	Result
2412	9.11	9.53	500	Pass
2437	9.10	9.49	500	Pass
2462	10.06	9.56	500	Pass

Note: A(B) Represent the value of antenna A and B, The worst data is Antenna B ,only shown Antenna B Plot.

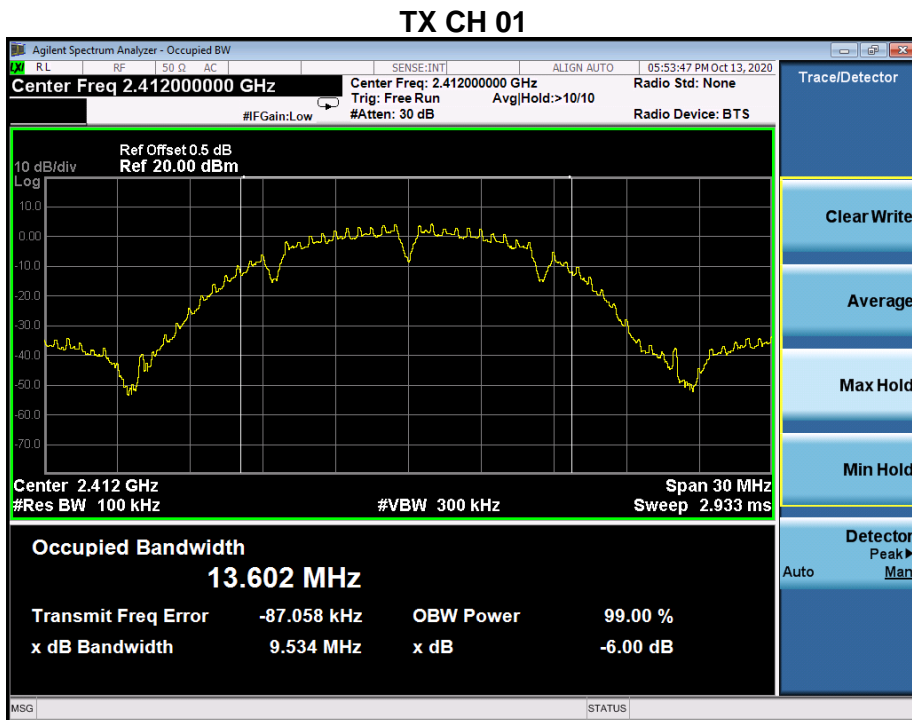

**TX CH 06**

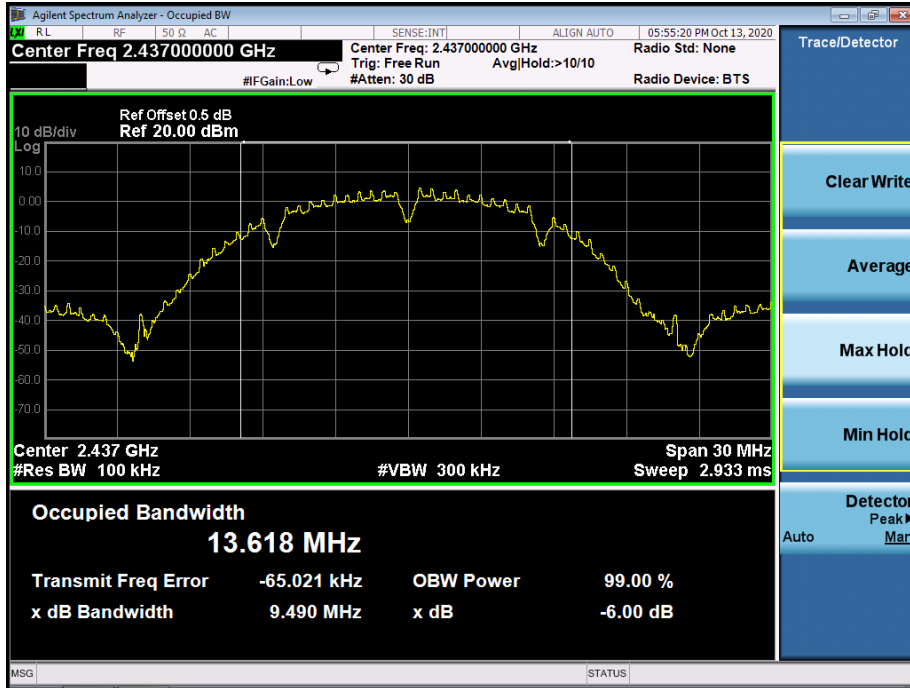

**TX CH 11**

