

SGS Germany GmbH

Test Report No.: S3W70003

FCC ID: 2AVB6-PA10006882

Order No.: S3W7

Pages: 28

Client: Christ Electronic Systems GmbH

Equipment Under Test: Touch-it CE OEM glass 7

Manufacturer / Importer: Christ Electronic Systems GmbH

Task: Compliance with the requirements mentioned below:

Test Specification(s):
[covered by accreditation]

- FCC 47 CFR Part 15
§15.107
§15.109
- ICES-003 Issue 6

Result: The EUT complies with the requirements of the test specifications.

The test report shall not be reproduced except in full without the written approval of the testing laboratory

The results relate only to the items tested as described in this test report.

approved by:

Date

Signature

Wössner
Group Leader

Nov 10, 2021

This document was signed electronically.

CONTENTS

1 Result Summary	3
2 References	4
2.1 Specification(s).....	4
2.2 Glossary	4
2.3 Information concerning FCC Equipment Authorization and Labelling	5
3 General Information.....	6
3.1 Identification of Client	6
3.2 Test Laboratory	6
3.3 Time Schedule	6
3.4 Participants	6
3.5 Environmental conditions	6
4 Equipment Under Test.....	7
4.1 Operational conditions.....	13
4.1.1 Software.....	13
4.1.2 Operation modes	13
4.2 Hardware Configuration.....	13
4.2.1 Components of the EUT.....	13
4.2.2 Interface description.....	13
4.2.2.1 Power supply port	13
4.2.2.2 Earthing and Grounding connections	14
4.2.2.3 Communication and signal ports	14
4.2.3 Cabling	14
4.2.4 Clock frequencies of the EUT resulting in determination of frequency range	14
4.2.5 External protection devices or measures.....	15
4.2.6 Modifications during the test.....	15
4.3 Deviations from Standard	15
5 Test Equipment.....	16
5.1 Test Facility	16
5.2 Measurement Uncertainty	17
5.3 Statement of Conformity & Decision Rule.....	17
6 Test Conditions and Results.....	18
6.1 Conducted disturbance (150 kHz to 30 MHz)	18
6.2 Radiated disturbances (30 MHz to 1000 MHz)	22
6.3 Radiated disturbances (1 GHz to 18 GHz).....	25
7 Disclaimer	28

The test report shall not be reproduced except in full without the written approval of the testing laboratory

1 Result Summary

This report presents the test procedures used and the results obtained during the performance of an FCC 47 CFR Part 15 test program. The test program was conducted to assess the ability of the tested sample to successfully satisfy the requirements specified in the references listed in Section 2 of this report.

Tables of Results:

Phenomena	Reference	Frequency range	Criteria	Verdict ¹
Conducted Emission AC power port ²	FCC 47 CFR Part 15 §15.107	150 kHz – 30 MHz	Class A	P Note: Class B passed also
Radiated Emission Electric Field	FCC 47 CFR Part 15 §15.109	30 MHz - 1 GHz	Class A	P Note: Class B passed also
Radiated Emission Electric Field	FCC 47 CFR Part 15 §15.109	1 GHz - 18 GHz ³	Class A	P

The test report shall not be reproduced except in full without the written approval of the testing laboratory

¹ **P** (Pass): test object meets the requirement; **F** (Fail): test object does not meet the requirement; **NA**: test case does not apply to the test object; **NR**: test case is not requested by the client; **NP**: test case was not performed

² According ANSI C.63.4 chapter 7.1: If the EUT normally receives power from another device that in turn connects to the public-utility ac power lines, measurements shall be made on that device with the EUT in operation to ensure that the device continues to comply with the appropriate limits while providing the EUT with power. If the EUT is operated only from internal or dedicated batteries, with no provisions for connection to the public utility ac power lines (600 VAC or less) to operate the EUT (such as an adapter), then ac power-line conducted measurements are not required.

³ See chapt. 4.2.4; Clock frequencies of the EUT resulting in determination of frequency range

2 References

2.1 Specification(s)

- [1] FCC 47 CFR Part 15:
Code of Federal Regulations. Title 47: Telecommunication Part 15: Radio Frequency Devices
- [2] ANSI C63.4-2014, American National Standard for Methods of Measurement of Radio-Noise Emissions from Low-Voltage Electrical and Electronic Equipment in the Range of 9 kHz to 40 GHz
- [3] FCC Public Notice DA 09-2478; Nov 25, 2009; Office of Engineering and Technology Clarifies Use of Recently Published ASC C63®
- [4] Measurement Standards for Compliance Testing of Intentional and Unintentional Radiators under Part 15

2.2 Glossary

AC	Alternating Current
AMN	Artificial Mains Network
AV	Average Detector
DC	Direct Current
EMC	Electromagnetic Compatibility
EUT	Equipment Under Test
HW	Hardware
LISN	Line Impedance Stabilization Network
QP	Quasi Peak Detector

The test report shall not be reproduced except in full without the written approval of the testing laboratory

2.3 Information concerning FCC Equipment Authorization and Labelling

CERTIFICATION (47 CFR Section 2.907)

Certification is the most rigorous approval process for RF Devices with the greatest potential to cause harmful interference to radio services. It is an equipment authorization issued by an FCC-recognized Telecommunication Certification Body (TCB) based on an evaluation of the supporting documentation and test data submitted by the responsible party (e.g., the manufacturer or importer) to the TCB. Testing is performed by an FCC-recognized accredited testing laboratory. Information including the technical parameters and descriptive information for all certified equipment is posted on a Commission-maintained public database. In addition, equipment subject to approval using the Supplier's Declaration of Conformity (SDoC) procedure can optionally use the Certification procedure.

SUPPLIER'S DECLARATION OF CONFORMITY (47 CFR Section 2.906) → SDoC

Supplier's Declaration of Conformity (SDoC) is a procedure that requires the party responsible for compliance ensure that the equipment complies with the appropriate technical standards. The responsible party, who must be located in the United States, is not required to file an equipment authorization application with the Commission or a TCB. Equipment authorized under the SDoC procedure is not listed in a Commission database. However, the responsible party or any other party marketing the equipment must provide a test report and other information demonstrating compliance with the rules upon request by the Commission. The responsible party has the option to use the certification procedure in place of the SDoC procedure.

The key FCC rule sections for SDoC are:

- Section 2.906 Supplier's Declaration of Conformity
- Section 2.909 Responsible party
- Section 2.931 Responsibilities
- Section 2.938 Retention of records
- Section 2.1072 Limitations on Supplier's Declaration of Conformity
- Section 2.1074 Identification
- Section 2.1077 Compliance Information

See Guidance on the use of SDoC in [896810 D01 SDoC v02](#) and [896810 D02 SDoC FAQ v01r02](#).

As the EMC-Lab of SGS Germany GmbH is an FCC-recognized accredited testing laboratory, this test report can be used as basis for both procedures.

Based on §15.3 the following description for locations and its emission classes is defined:

(h) **Class A digital device.** A digital device that is marketed for use in a commercial, industrial or business environment, exclusive of a device which is marketed for use by the general public or is intended to be used in the home.

(i) **Class B digital device.** A digital device that is marketed for use in a residential environment notwithstanding use in commercial, business and industrial environments. Examples of such devices include, but are not limited to, personal computers, calculators, and similar electronic devices that are marketed for use by the general public.

Based on §15.105 the relevant **information to the limit class** has to be included in the manual.

Guidelines for **labeling and user information for RF** devices are contained in the following documents:

- [784748 D01 General labeling and Notification v09r01](#) provides general guidance for Part 15 and Part 18 labeling and user information.
- [748748 D02 e labeling v02](#) provides guidelines for displaying label information electronically (e-label).

See also important summarized information in FCC public notice [DA 19-91](#), February 15, 2019.

For guidance concerning **integration of already FCC-certified wireless transmitter modules in host systems** see [996369 D04 Module Integration Guide v01](#) Modular Transmitter Integration Guide – Guidance for Host Product Manufacturers.

3 General Information

3.1 Identification of Client

Christ Electronic Systems GmbH
Regulatory Affairs
Alpenstraße 34
87700 Memmingen
Ingo Röhr

3.2 Test Laboratory

SGS Germany GmbH
Hofmannstraße 50
81379 München

3.3 Time Schedule

Delivery of EUT: 05.10.2021
Start of test: 07.10.2021
End of test: 07.10.2021

3.4 Participants

Name	Function
Sven Suurmaa	Accredited testing, Editor

3.5 Environmental conditions

During the measurement the environmental conditions were within the listed ranges:

Temperature: 20 - 26 °C
Humidity: 30 - 60 %

The test report shall not be reproduced except in full without the written approval of the testing laboratory

4 Equipment Under Test

All information regarding the EUT(s) was provided by the customer and has been approved by customer during report-review-process.

Test item description	Touch-it CE OEM
Trade Mark.....	None
Manufacturer / Importer ..	Christ Electronic Systems GmbH
Model/Type	Touch-it CE OEM glass 7 // Prod. ID: PA10006882**
Number of tested samples....	1
Serial Number(s)	0216031-000-001
Ratings	24 V DC / 0.75 A

** xxxxxx pertains to model variants with different interface connectors and pushbuttons
 Touch-it CE OEM glass 7, Prod. ID: PA10006882
 Touch-it CE OEM glass 7, Prod. ID: PA10xxxxxx

Where “xxxxxx” in the ID Number may be any numeric characters. These models are variants of the Touch-it CE OEM glass 7 and are differed regarding the Interface connectors and the pushbuttons.
 These variants are a subset of the ID: PA10006882

The EUT is part of a machine tool. A application is running on the EUT which makes it possible to communicate with the main computer of the system. It is the HMI of the machine and via touch screen it is possible to chose different options. The EUT has different setups with different amount of buttons and connectors, depending on the machine it will be used.

There are the two basic variations as a completion of the Touch-it CE OEM glass 7.
 All other sub models of these basic variations have less pushbuttons and connectors and therefore aren't considered as worst case.
 The difference between the two basic variations are:
 Variation 1: All buttons are connected to the outside via M27 connector.
 Variation 2: All buttons are connected to the outside via M12 connector

There are only static signals on these interfaces. Variation 1 was considered as worst case as the connected cable during the test was unshielded and all M12 cables for variation 2 will be shielded according to customer information. In addition the interfaces transmit only static signals.

The test report shall not be reproduced except in full without the written approval of the testing laboratory

The test report shall not be reproduced except in full without the written approval of the testing laboratory

Variation 1 [EUT]	Variation 2
	 
<p>X1 → M12-4 bis M12-9 X2 → M12-3 X4 → M12-1 X5 → M12-2</p>	



Front view EUT



Side view EUT

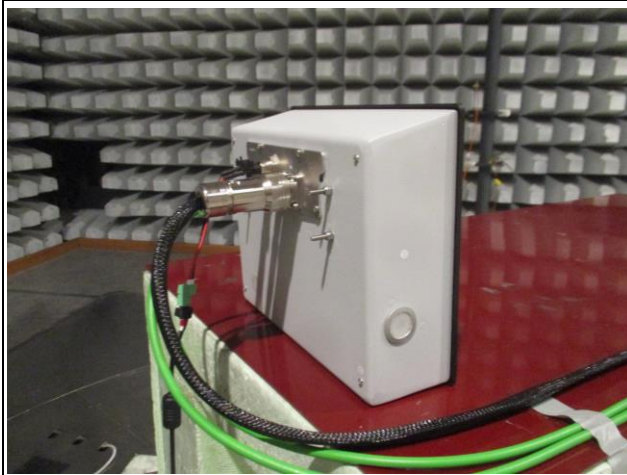

Side view EUT

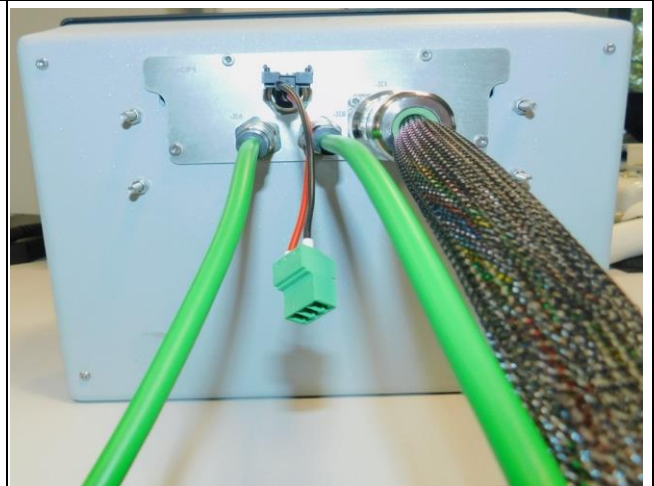

Rear view EUT

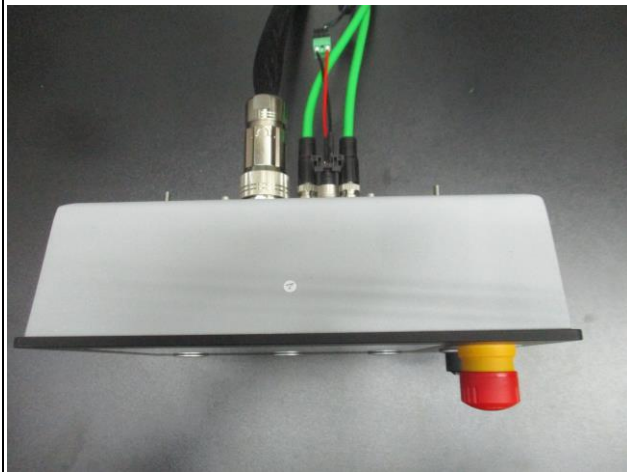

Top view EUT



Communication ports EUT



Interface X4 Ethernet cable EUT



Interface X5 Ethernet cable EUT

The test report shall not be reproduced except in full without the written approval of the testing laboratory



Interface X4, X5 connector EUT



Enthernet connector EUT



Interface X1 (Intercontec 627) cable EUT



Interface X1 (Intercontec 627) connector EUT



Interface X2 Power cable EUT, PSU FSP is AE and not part of the EUT

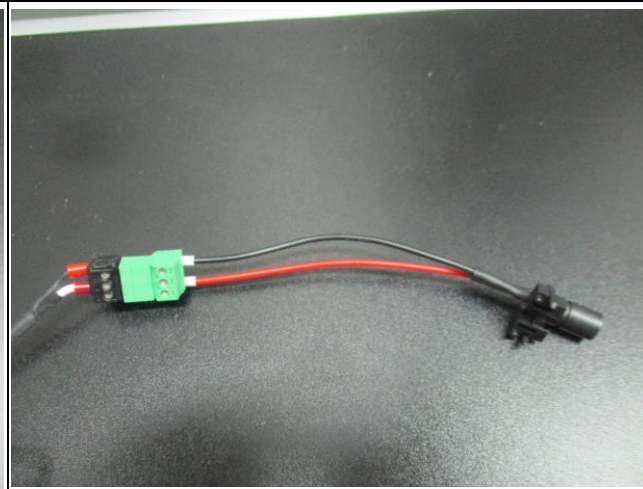

Interface X2 connector EUT

The test report shall not be reproduced except in full without the written approval of the testing laboratory



Figure 4-1: Touch-it CE OEM and accessories

The test report shall not be reproduced except in full without the written approval of the testing laboratory



Figure 4-2: Copy of type plate

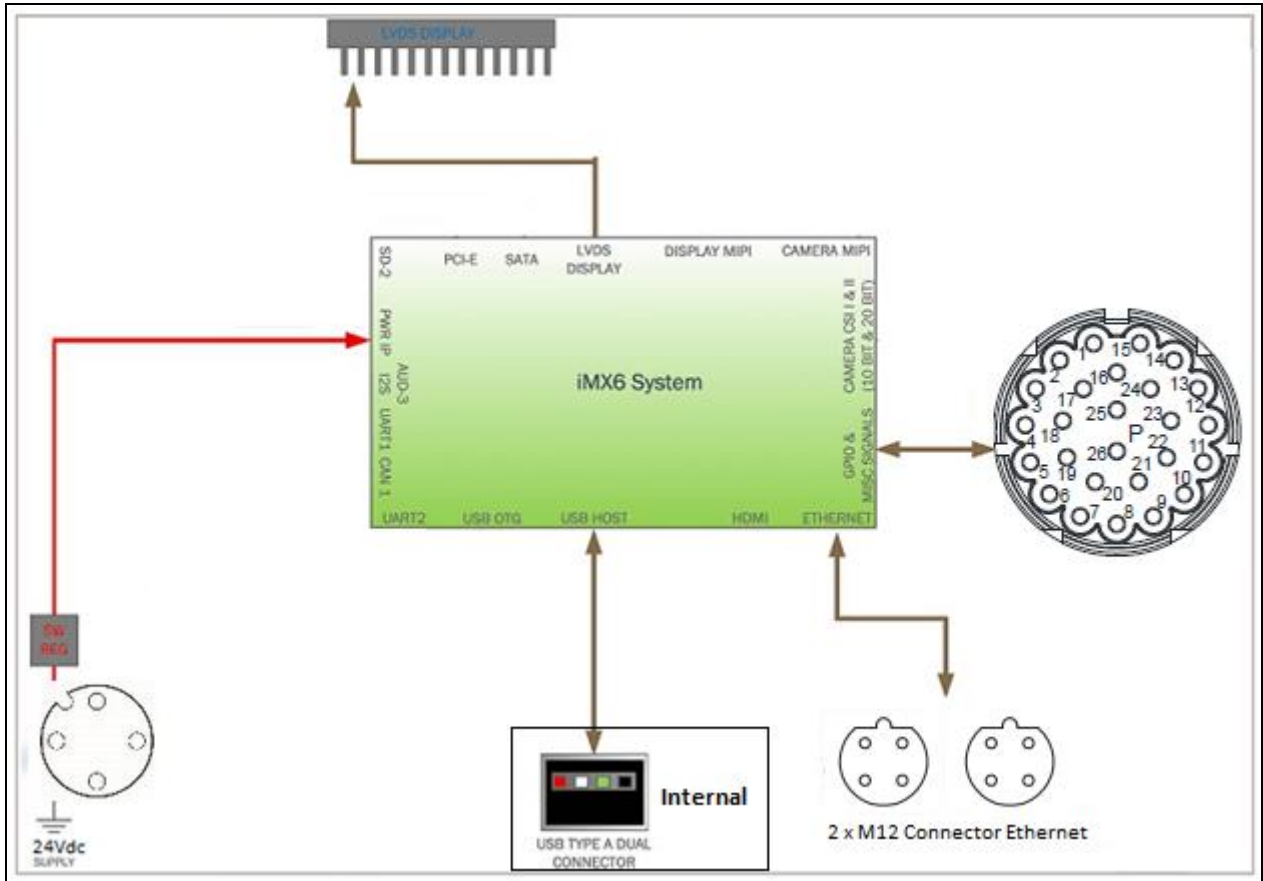

Figure 4-3: Block diagram of function

The test report shall not be reproduced except in full without the written approval of the testing laboratory

4.1 Operational conditions

4.1.1 Software

Software necessary for operating, controlling and monitoring the EUT:

Name	Identification Code/Issue	Task
None	--	--

4.1.2 Operation modes

Test operation: 100Mbit traffic Ethernet, CPU 100%, RAM 25%

Other operation:

Operation mode 1 :

Operation mode 2 :

4.2 Hardware Configuration

4.2.1 Components of the EUT

Name	Identification Code/Issue/Serial Number	Interface type	Quantity
Touch-it CE OEM glass 7	0216031-000-001	Input 24 V DC	1

4.2.2 Interface description

All interfaces are identified independent whether they are tested or not.

4.2.2.1 Power supply port

Power Supply	Type (AC/DC)	Voltage	Frequency	Current	Power
Tested voltage secondary	DC	24 V	--	0,75A	18 VA
Tested voltage primary	AC	120 V	60 Hz	Rated 1.5 A	Not rated
Rated voltage range	AC	100 – 240 V	50 / 60 Hz	1.5 A	Not rated

4.2.2.2 Earthing and Grounding connections 4

Type	Task	Connected to	Test E/I/NA
Functional Earthing	Functional purpose	Earth	N/A

4.2.2.3 Communication 5 and signal 6 ports

Type	Bit rate/frequency/ Signal	Task	Connected to
Ethernet (X4)	100Mbps	Communication	Switch/Hub
Ethernet (X5)	100Mbps	Communication	Switch/Hub

4.2.3 Cabling

Name	Identification Code/Issue/ Serial Number	shield	Description of Connection / plug type	length	Quantity
Ethernet	--	yes	Ethernet connector	100m	2
X1	---	no	Interconnect 627	25m	1
X2	---	no	24 V DC power line	25m	1

4.2.4 Clock frequencies of the EUT resulting in determination of frequency range

System / Sub-system	Highest clock frequency
CPU	1GHz

The result of the table above with the highest frequency of internal source is basis of the determination of the necessity of measurement above 1 GHz. The highest internal source of an EUT is defined as the highest frequency generated or used within the EUT or on which the EUT operates or tunes.

See **FCC §15.33 a)** for relevant frequency range of **intentional radiators**.

See **FCC §15.33 b)** for relevant frequency range of **unintentional radiators**.

See e.g. the following table taken from FCC §15.33 b) 1)

-
- 4 Safety ground, functional earth, specific ground connections
 - 5 connections to communication networks, analog, Ethernet, antenna, wireless, GPS,
 - 6 Signaling, monitoring and control ports

Highest frequency generated or used in the device or on which the device operates or tunes (MHz)	Upper frequency of measurement range (MHz)
Below 1.705	30
1.705-108	1000
108-500	2000
500-1000	5000
Above 1000	5th harmonic of the highest frequency or 40 GHz, whichever is lower

4.2.5 External protection devices or measures

EMC relevant external protection devices or measures specified in the user's manual (e.g. over-voltage, shielding, bonding and grounding).

None

4.2.6 Modifications during the test

None

4.3 Deviations from Standard

None

The test report shall not be reproduced except in full without the written approval of the testing laboratory

5 Test Equipment

5.1 Test Facility

The EMC-tests are carried out in the EMC-laboratory of SGS Germany, Consumer and Retail, Hofmannstraße 50, 81379 München, Germany.

Chamber	1	2	3	4 / 5	6	7	
Dimensions (net)	17.7 * 10.8 * 6.8 m	9.6 * 8.5 * 5.3 m	7.4 * 6.6 * 5.2 m	4.1 * 3.5 * 3.5m	6.4 * 4.3 * 4.3m	4.58 * 4.28 * 3.01m	
Max. Door Exit (w x h)	2.9 * 3.86 m	3.9 * 4.0 m	2.0 * 2.7 m	0.9 * 2.25 m	1.8 * 3.0 m	1.2 * 2.050 m	
Shielding material	Sheet steel (Thickness: 1.5mm on floor, 1.0 mm on walls and ceiling)	Sheet steel	Sheet steel	Sheet steel	Sheet steel	Sheet steel	
Absorbers	Hybrid absorbers on walls and ceiling (TDK), length 1 m	Hybrid absorbers on walls and ceiling (E+C), length 0.5 m	Hybrid absorbers on walls and ceiling (E+C), length 0.3 m	Without absorbers	Without absorbers	Hybrid absorbers on walls and ceiling	
Floor	Metallic ground plane floor load: 12 t/m ²	Metallic ground plane floor load: 1.5 t/m ²	Metallic ground plane floor load: 1 t/m ²	Metallic ground plane	Metallic ground plane	Metallic ground plane	
Turntable	Ø 4 m / 7 t	Ø 3.2 m / 1.5 t	Ø 2.0 m / 1 t				
Listings		VCCI-listed until Oct. 2022, Reg. No. R-12623, G-10266			VCCI-listed until Oct. 2022, Reg. No C-12866 & T-11942		
Specials	<p>Emission: 30 – 1000 MHz (d = 10 m) - NSA acc. to: · CISPR 16-1-4 · ANSI C63.4</p> <p>1 – 18 GHz (d = 3 m) Site VSWR 1 – 18 GHz acc. to CISPR 16-1-4</p> <p>Immunity: Field uniformity 27 – 6000 MHz acc. IEC/EN 61000-4-3</p>	<p>Emission: 30 – 1000 MHz (d = 3 m) - NSA acc. to: · CISPR 16-1-4 · ANSI C63.4</p> <p>1 – 18 GHz (d = 3 m) Site VSWR 1 – 18 GHz acc. to CISPR 16-1-4</p> <p>Immunity: Field uniformity 80 – 6000 MHz acc. IEC/EN 61000-4-3</p>	<p>Emission: 30 – 1000 MHz (d = 3 m) - NSA acc. to: · CISPR 16-1-4 · ANSI C63.4</p> <p>1 – 18 GHz (d = 3 m) Site VSWR 1 – 18 GHz acc. to CISPR 16-1-4</p> <p>Immunity: Field uniformity 80 – 6000 MHz acc. IEC/EN 61000-4-3</p>				For automotive components only

The test report shall not be reproduced except in full without the written approval of the testing laboratory

FCC (Federal Communication Commission): Recognition by Bundesnetzagentur (BNetzA-CAB-14/21-09) and Designation as CAB (Conformity Assessment Body) : Designation Number DE0013; Test firm Registration #: 366296
Designation KBA (Kraftfahrt-Bundesamt) as Technical Service category A and D. Registration Number: KBA-P 00083-97
CB Testing Laboratory under the responsibility of SGS CEBEC as National Certification Body and to carry out testing within the IECEE CB Scheme .
Designation No. for RRA (Radio Research Agency) in Korea ; EU0145
VCCI Member No. 2793

5.2 Measurement Uncertainty

As far as the underlying standards include requirements concerning the uncertainty of measuring instruments or measuring methods, they are met.

The data and results referenced in this document are true and accurate. The reader is cautioned that there may be errors within the calibration limits of the equipment and facilities.

The expanded measurement uncertainty of the measuring chain was calculated for all tests according to the "ISO Guide to the expression of uncertainty in measurement (GUM)". The results are documented in an "internal controlled document".

The measuring accuracy for all measuring devices is given in their technical description. The measuring instruments, including any accessories, are calibrated respectively verified to ensure the necessary accuracy. Depending on the kind of measuring equipment it is checked within regular intervals or directly before the measurement is performed. Adjustments are made and correction factors applied to measured data in accordance with the specifications of the specific instrument.

The expanded measurement instrumentation uncertainty of our Test Laboratory meets the requirements of IEC CISPR 16-4-2 "Specification for radio disturbance and immunity measuring apparatus and methods – Part 4-2: Uncertainties, statistics and limit modeling – Measurement instrumentation uncertainty" and the relevant basic standards for all listed Tests.

Expanded uncertainty:

Conducted emission	0.15 – 30 MHz	+ 2.2 dB / -2.5 dB
Radiated emission	30 – 1000 MHz	+3.1 dB / -3.9 dB
Radiated emission	1 – 6 GHz	+3.9 dB / -5.2 dB
Radiated emission	6 – 18 GHz	+4.2 dB / -5.7 dB

5.3 Statement of Conformity & Decision Rule

Concerning radiated/conducted emission, if not otherwise stated in the relevant standards, the decision rule for statement of conformity is based on U_{CISPR} given in CISPR 16-4-2. When the expanded uncertainty calculations of the EMC-lab for the single emission tests is below U_{CISPR} , then it can be considered, based on ILAC-G8, that the measurement result is valid without any need of adaption and e.g. a result of 0 dB to the limit can be stated as pass.

Concerning immunity tests the required levels are created and coupled within the required uncertainty limits which are given in the relevant standards or are typical for that kind of phenomena. Unless differently specified in the standards, to assess the conformity of the EUT, the laboratory applies the decision rule defined in the referenced product standards. The given compliance criteria listed in the basic and product standards (e.g. A, B, C; functional status, ...) are related with the pass/fail- and performance criteria of the tested sample given from the client or test plan.

6 Test Conditions and Results

The test results in the report refer exclusively to the test object described in section 4 and the test period in section 3.3. The results apply to the sample(s) as received.

6.1 Conducted disturbance (150 kHz to 30 MHz)

Phenomena	Reference	Frequency Range	Criteria	Verdict ¹
Conducted Emission AC Power Ports	FCC 47 CFR Part 15 §15.107	150 kHz – 30 MHz	Class A	P Note: Class B passed also

Tested by : Suurmaa / Njoteng

Test date : 2021-10-08 Test location : EMC chamber No. 02

Test procedure

Measured levels of powerline conducted emission are the radio-noise voltage levels across the 50 Ω LISN port (to which the EUT is connected) terminated into a 50 Ω EMI receiver. All radio-noise voltage measurements are made on each current carrying conductor at the plug end of the EUT power cord. The measurement is performed using a receiver with peak and average detector.

Only if the measured peak value is near or above the quasi-peak limit the detector function is changed to quasi-peak for final measurement of the highest voltage levels.

Exploratory emission measurements are to be performed considering operation states and cable arrangement to evaluate configuration with highest emission levels (C63.4-2014, Clause 7.3.3 and 7.3.4).

Table-top equipment is arranged 80 cm above ground plane.

Acc. ANSI C63.4 chapter 10.2.8.3: AC power-line conducted emissions measurements are to be separately carried out only on each of the phase ("hot") line(s) and (if used) on the neutral line(s), but not on the ground [protective earth) line(s).

EMC-Test-SW: EMC32 version 10.60.15 (R&S)

Sample Calculation with all conversion and correction factors used:

$$\sum CF = CF_{\text{Cables}} + CF_{\text{LISN}}$$

Instruments and accessories

ID	Description	Manufacturer	Model	Serial No.	Status	Cal. date	Cal. due
P1327	EMI receiver	R&S	ESU40	100048	cal	Mar 17, 2021	Mar 2022
P0337	EMC chamber 2	Siemens			chk		
P2623	Power Supply	dataTec	Chroma 61605, AC-/DC Source	6160500029 47	ind		
P0438	LISN MZ1 (integrated pulse limiter P0993)	R&S	ESH3-Z5	891843/006	cal	Mar 16, 2021	Mar 2023

cal = Calibration, car = Calibration restricted use, chk = Check, chr = Check restricted use, cpu = Check prior to use, calchk = Calibration and check, ind = for indication only, cnn = Calibration not necessary, service = Wartung (Service), man = Maintenance, calservice = Calibration & Service, chkservice = Check & Service, calchkservice = Calibration & Check & Service

Photo documentation of the test set-up:

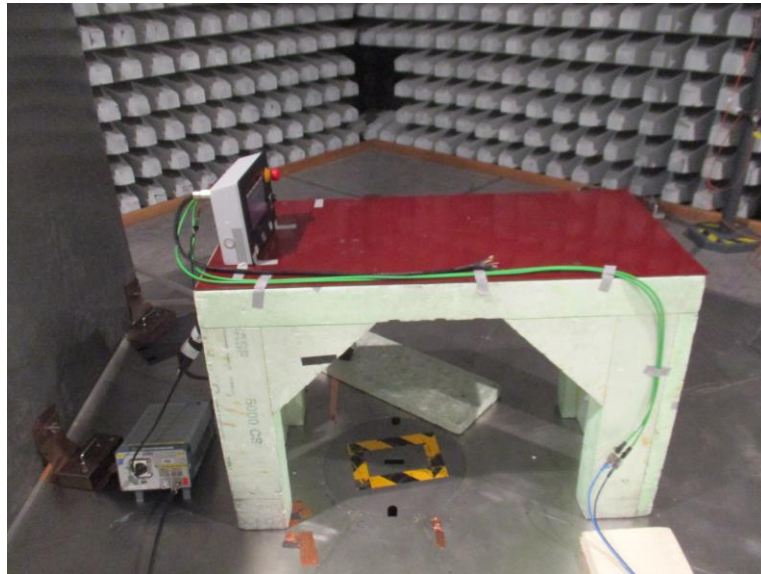

Figure 6-1: test setup Low voltage AC mains continuous disturbance

Result:

verdict:	pass
----------	-------------

For detailed results, please see below.

The test report shall not be reproduced except in full without the written approval of the testing laboratory

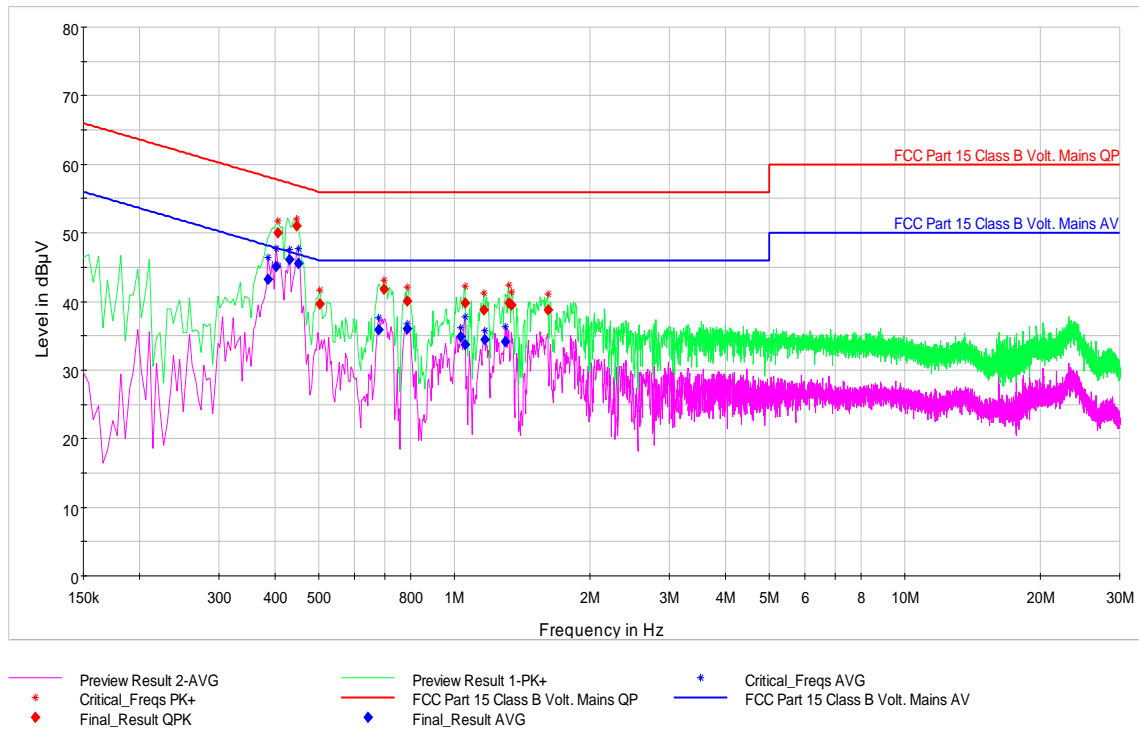

Figure 6-2: Graphical presentation Low voltage AC mains continuous disturbance, Neutral line

Result table:

Frequency (MHz)	QuasiPeak (dBµV)	Average (dBµV)	Limit (dBµV)	Margin (dB)	Meas. Time (ms)	Bandwidth (kHz)	Line	PE	Corr. (dB)
0.386000	---	43.24	48.15	4.91	1000.0	9.000	N	GND	10
0.402000	---	45.16	47.81	2.65	1000.0	9.000	N	GND	10
0.406000	50.05	---	57.73	7.68	1000.0	9.000	N	GND	10
0.430000	---	46.16	47.25	1.09	1000.0	9.000	N	GND	10
0.446000	51.10	---	56.95	5.85	1000.0	9.000	N	GND	10
0.450000	---	45.54	46.88	1.34	1000.0	9.000	N	GND	10
0.502000	39.69	---	56.00	16.31	1000.0	9.000	N	GND	10
0.678000	---	35.91	46.00	10.09	1000.0	9.000	N	GND	10
0.698000	41.82	---	56.00	14.18	1000.0	9.000	N	GND	10
0.786000	---	35.97	46.00	10.03	1000.0	9.000	N	GND	10
0.786000	40.03	---	56.00	15.97	1000.0	9.000	N	GND	10
1.030000	---	34.91	46.00	11.09	1000.0	9.000	N	GND	10
1.054000	39.72	---	56.00	16.28	1000.0	9.000	N	GND	10
1.058000	---	33.66	46.00	12.34	1000.0	9.000	N	GND	10
1.162000	38.74	---	56.00	17.26	1000.0	9.000	N	GND	10
1.166000	---	34.47	46.00	11.53	1000.0	9.000	N	GND	10
1.298000	---	34.10	46.00	11.90	1000.0	9.000	N	GND	10
1.318000	39.78	---	56.00	16.22	1000.0	9.000	N	GND	10
1.338000	39.49	---	56.00	16.51	1000.0	9.000	N	GND	10
1.610000	38.74	---	56.00	17.26	1000.0	9.000	N	GND	10

Note: As class B limit is passed class A is also

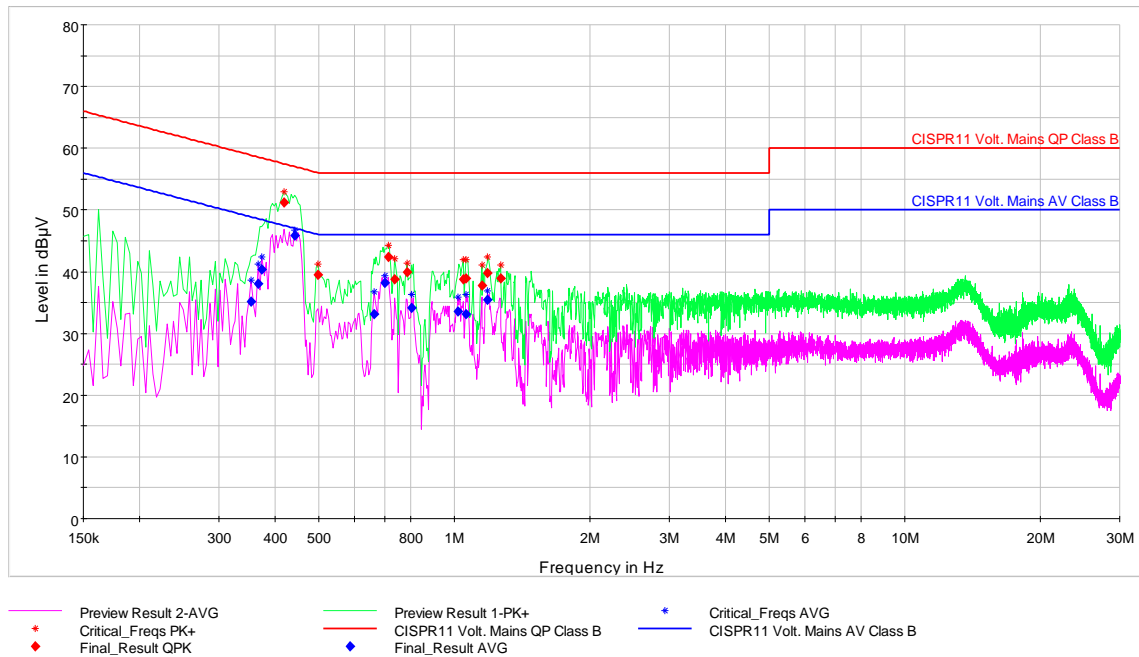

Figure 6-3: Graphical presentation Low voltage AC mains continuous disturbance, Phase

Result table:

Frequency (MHz)	QuasiPeak (dBµV)	Average (dBµV)	Limit (dBµV)	Margin (dB)	Meas. Time (ms)	Bandwidth (kHz)	Line	PE	Corr. (dB)
0.354000	---	35.13	48.87	13.74	1000.0	9.000	L1	GND	10
0.366000	---	38.12	48.59	10.48	1000.0	9.000	L1	GND	10
0.374000	---	40.33	48.41	8.08	1000.0	9.000	L1	GND	10
0.418000	51.18	---	57.49	6.31	1000.0	9.000	L1	GND	10
0.442000	---	45.79	47.02	1.23	1000.0	9.000	L1	GND	10
0.498000	39.48	---	56.03	16.55	1000.0	9.000	L1	GND	10
0.662000	---	33.07	46.00	12.93	1000.0	9.000	L1	GND	10
0.702000	---	38.13	46.00	7.87	1000.0	9.000	L1	GND	10
0.714000	42.43	---	56.00	13.57	1000.0	9.000	L1	GND	10
0.738000	38.79	---	56.00	17.21	1000.0	9.000	L1	GND	10
0.786000	39.91	---	56.00	16.09	1000.0	9.000	L1	GND	10
0.802000	---	34.16	46.00	11.84	1000.0	9.000	L1	GND	10
1.018000	---	33.57	46.00	12.43	1000.0	9.000	L1	GND	10
1.046000	38.72	---	56.00	17.28	1000.0	9.000	L1	GND	10
1.062000	38.98	---	56.00	17.02	1000.0	9.000	L1	GND	10
1.062000	---	33.18	46.00	12.82	1000.0	9.000	L1	GND	10
1.150000	37.70	---	56.00	18.30	1000.0	9.000	L1	GND	10
1.186000	39.78	---	56.00	16.22	1000.0	9.000	L1	GND	10
1.186000	---	35.49	46.00	10.51	1000.0	9.000	L1	GND	10
1.266000	38.92	---	56.00	17.08	1000.0	9.000	L1	GND	10

Note: As class B limit is passed class A is also

The test report shall not be reproduced except in full without the written approval of the testing laboratory

6.2 Radiated disturbances (30 MHz to 1000 MHz)

Phenomena	Reference	Frequency Range	Criteria	Verdict ¹
Radio Disturbance Electric Field	FCC 47 CFR Part 15 §15.109	30 MHz - 1 GHz distance 3	Class A	P Note: Class B passed also

Tested by : Suurmaa / Njoteng

Test date : 2021-10-07 Test location : EMC chamber No. 02

Test procedure:

Radiated measurements are performed in a semi-anechoic chamber meeting the normalized site attenuation of ANSI C63.4 and listed with the FCC. The applicable frequency spectrum is scanned with a calibrated RF measuring system using an appropriate broadband antenna and an EMI-receiver/spectrum analyzer and compared to the required limits. The measuring instrument performs the field strength calculations automatically. The measuring software provides resident AF and CF figures for individual antennas and cables. The receiver/analyzer is set to "peak" mode from 30 MHz to 1 GHz. On any emission of concern, the receiver is set to quasi-peak mode.

"Maximization" of each suspect frequency is accomplished by a combination of a 360° azimuth search using a turntable and varying the antenna to ground plane height from 1 m to 4 m. Also, both the vertical and horizontal polarization is scanned in the required frequency range per ANSI C63.4.

Maximization of emission results starts at 0° of the turn table with antenna in horizontal polarization is set to 1 m. While the turntable slowly moves to 360°, the spectrum analyzer is sweeping from 30 to 1000 MHz and maximum data is recorded. Antenna is set to 2 m and turntable slowly moves back to 0° while the spectrum analyzer is sweeping again. This is repeated until the antenna height of 4 m is reached.

The antenna polarization is set to vertical and the procedure described above is repeated. For each frequency the measuring software stores the maximum level as well as the corresponding settings of turntable and antenna. An azimuth resolution of about 3° is realized using this method.

At least the six highest frequencies are selected automatically by the software for performing the final measurements.

At each of these frequencies the turntable as well as the antenna is set to the corresponding settings. Then the antenna is slowly moved 50 cm down/up related to initial position while the receiver is measuring at this frequency. The highest emission level and the corresponding height are recorded. At this final position, the measurement is performed with quasi-peak detector.

Exploratory emission measurements are to be performed considering operation states and cable arrangement to evaluate configuration with highest emission levels (C63.4, Clause 8.3.1 and 8.3.2).

Table-top equipment is arranged 80 cm above ground plane.

EMC-Test-SW: EMC32 version 10.60.15 (R&S)

Sample Calculation with all conversion and correction factors used:

$$\sum CF = CF_{\text{Cables}} + CF_{\text{Antenna}}$$

Instruments and accessories

ID	Description	Manufacturer	Model	Serial No.	Status	Cal. date	Cal. due
P1327	EMI receiver	R&S	ESU40	100048	cal	Mar 17, 2021	Mar 2022
P2623	Power Supply	dataTec	Chroma 61605, AC-/DC Source	6160500029 47	ind		
P1283	Mast (MZ2)	innco GmbH	MA 4740-XPET	MA4000/170/ 13470706/L	cnn		
P0018	antenna	Chase	CBL6111A	1566	cal	May 26, 2021	May 2023
P0337	EMC chamber 2	Siemens			chk		
P1284	Controller	innco GmbH	CO 3000	CO3000/914/ 37830316/L	cnn		

cal = Calibration, car = Calibration restricted use, chk = Check, chr = Check restricted use, cpu = Check prior to use, calchk = Calibration and check, ind = for indication only, cnn = Calibration not necessary, service = Wartung (Service), man = Maintenance, calservice = Calibration & Service, chkservice = Check & Service, calchkservice = Calibration & Check & Service

Photo documentation of the test set-up:



Figure 6-4: test setup for Radiated disturbances 30 MHz to 1000 MHz

Result:

verdict:	pass
----------	-------------

For detailed results, please see below.

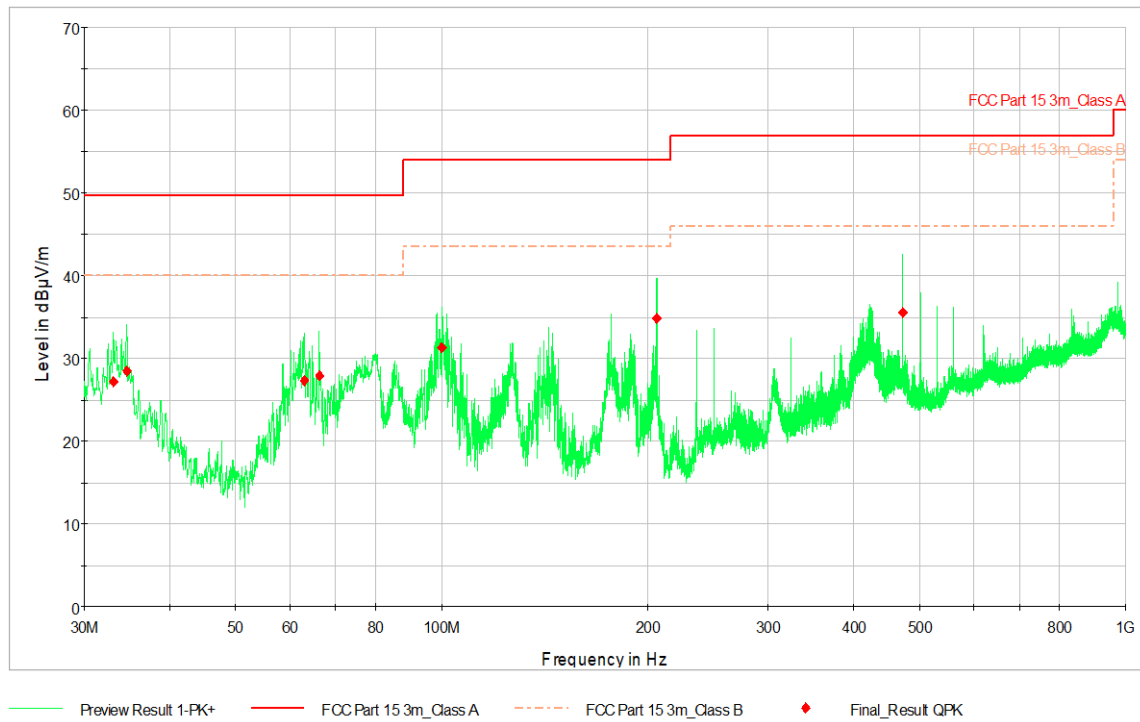

Figure 6-5: Graphical presentation Radiated disturbances 30 MHz to 1000 MHz

Result table:

Frequency (MHz)	QuasiPeak (dBµV/m)	Limit (dBµV/m)	Margin (dB)	Meas. Time (ms)	Bandwidth (kHz)	Height (cm)	Pol	Azimuth (deg)	Corr. (dB/m)	Sig Path (dB)
33.152500	27.22	49.60	22.38	1000.0	120.000	102.0	V	341.0	18	0
34.656000	28.50	49.60	21.10	1000.0	120.000	132.0	V	287.0	17	0
62.931500	27.35	49.60	22.25	1000.0	120.000	119.0	V	79.0	6	1
66.229500	27.91	49.60	21.69	1000.0	120.000	107.0	V	57.0	6	1
100.082500	31.32	54.00	22.68	1000.0	120.000	150.0	V	293.0	11	1
206.443000	34.85	54.00	19.15	1000.0	120.000	100.0	V	203.0	10	1
472.029000	35.51	56.90	21.39	1000.0	120.000	109.0	V	206.0	19	2

The test report shall not be reproduced except in full without the written approval of the testing laboratory

6.3 Radiated disturbances (1 GHz to 18 GHz)

Phenomena	Reference	Frequency Range	Criteria	Verdict ¹
Radio Disturbance Electric Field	FCC 47 CFR Part 15 §15.109	1 GHz - 18 GHz Distance 3 m	Class A	P

Tested by : Suurmaa / Njoteng

Test date : 2021-10-07 Test location : EMC chamber No. 2

Test Execution

Radiated measurements are performed in a semi-anechoic chamber meeting the normalized site attenuation of ANSI C63.4 as well as the Site VSWR requirements of CISPR16 and listed with the FCC. The applicable frequency spectrum is scanned with a calibrated RF measuring system using an appropriate broadband antenna and an EMI-receiver/spectrum analyzer and compared to the required limits. The measuring instrument performs the field strength calculations automatically. The measuring software provides resident AF and CF figures for individual antennas and cables. The receiver/analyzer is set to "peak" mode in the relevant frequency range. On any emission of concern, the receiver is set to average mode.

For EUTs having a size larger than the beamwidth of the antenna, appropriate countermeasures shall be taken, e.g. increasing the measuring distance or different antenna positions (lateral) to scan the complete surface of EUT.

"Maximization" of each suspect frequency is accomplished by a combination of a 360° azimuth search using a turntable and varying the antenna to ground plane height from 1 m to 4 m. Both, the vertical and horizontal polarization is scanned in the required frequency range per ANSI C63.4.

Maximization of emission results starts at 0° of the turn table with antenna in horizontal polarization is set to 1 m. While the turntable slowly moves to 360°, the spectrum analyzer is sweeping from 1 to X GHz and maximum data is recorded. Antenna is set to 1.5 m and turntable slowly moves back to 0° while the spectrum analyzer is sweeping again. This is repeated until the antenna height of 4 m is reached (step: 0.5m).

The antenna polarization is set to vertical and the procedure described above is repeated.

For each frequency the measuring software stores the maximum level as well as the corresponding settings of turntable and antenna. An azimuth resolution of about 3° is realized using this method.

At least the six highest frequencies are selected automatically by the software for performing the final measurements. At each of these frequencies the turntable as well as the antenna is set to the corresponding settings. Then the antenna is slowly moved 25 cm down/up related to initial position while the receiver is measuring at this frequency. The highest emission level and the corresponding height are recorded. At this final position, the measurement is performed with average detector.

Exploratory emission measurements are to be performed considering operation states and cable arrangement to evaluate configuration with highest emission levels (C63.4, Clause 8.3.1 and 8.3.2).

Final measurements were performed acc C63.4, clause 8.3.2.2 aimed at the emission source for receiving the maximum signal.

Table-top equipment is arranged 80 cm above ground plane.

EMC-Test-SW: EMC32 version 10.60.15 (R&S)

Sample Calculation with all conversion and correction factors used:

$$\sum CF = CF_{\text{Cables}} + CF_{\text{Antenna}} + CF_{\text{Preamplifier}}$$

Instruments and accessories

ID	Description	Manufacturer	Model	Serial No.	Status	Cal. date	Cal. due
P1327	EMI receiver	R&S	ESU40	100048	cal	Mar 17, 2021	Mar 2022
P2623	Power Supply	dataTec	Chroma 61605, AC-/DC Source	6160500029 47	ind		
P1283	Mast (MZ2)	innco GmbH	MA 4740-XPET	MA4000/170/ 13470706/L	cnn		
P0337	EMC chamber 2	Siemens			chk		
P1590	preamplifier (MZ2)	Kuhne electronic	KU LNA BB 202 A		cal	Mar 24, 2020	Mar 2022
P1575	antenna (MZ2)	R&S	HL050	100097	cal	May 20, 2020	May 2022
P1284	Controller	innco GmbH	CO 3000	CO3000/914/ 37830316/L	cnn		

cal = Calibration, car = Calibration restricted use, chk = Check, chr = Check restricted use, cpu = Check prior to use, calchk = Calibration and check, ind = for indication only, cnn = Calibration not necessary, service = Wartung (Service), man = Maintenance, calservice = Calibration & Service, chkservice = Check & Service, calchkservice = Calibration & Check & Service

Photo documentation of the test set-up:

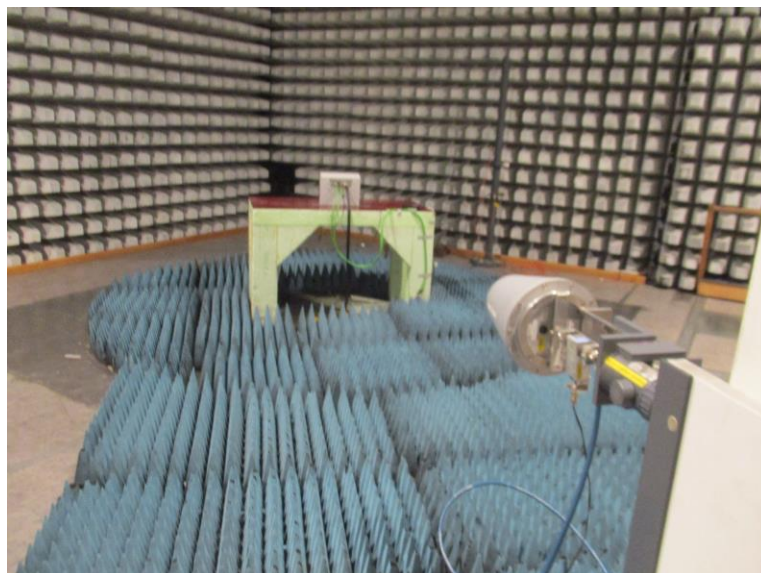

Figure 6-6: test setup for radiated disturbances 1 GHz to 18 GHz

Result:

verdict:	pass
----------	-------------

For detailed results, please see below.

The test report shall not be reproduced except in full without the written approval of the testing laboratory

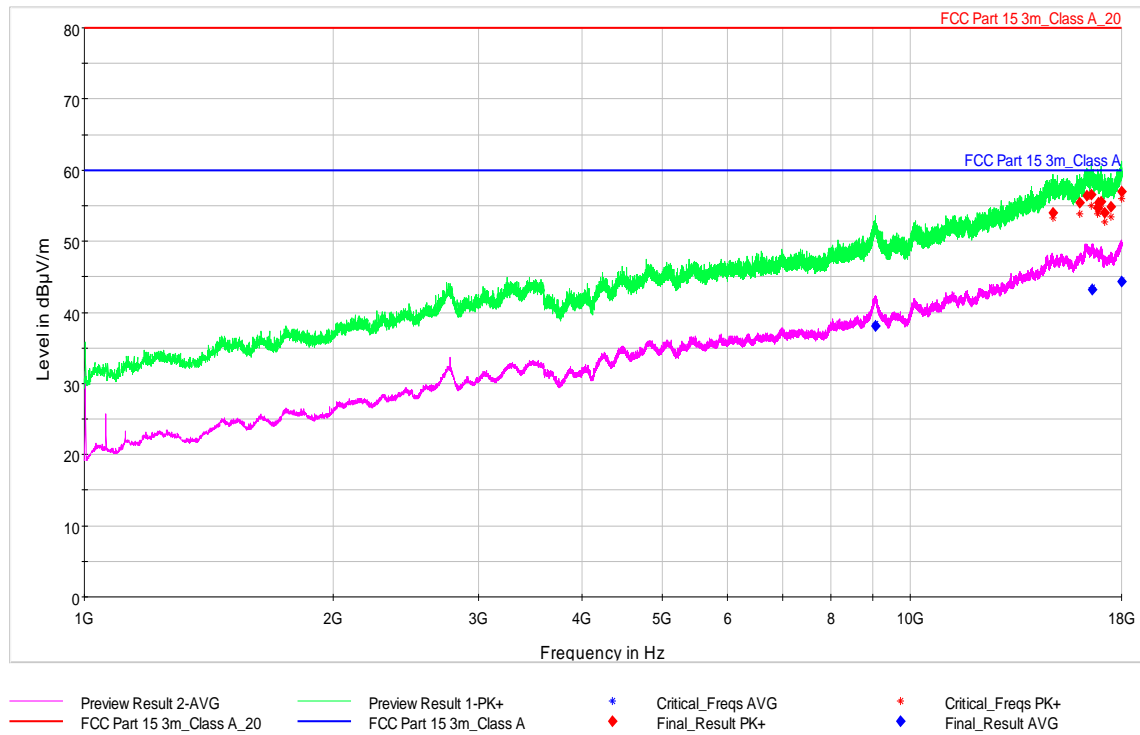

Figure 6-7: Graphical presentation Radiated disturbances 1 GHz to 18 GHz

Result table:

Frequency (MHz)	MaxPeak (dBµV/m)	Average (dBµV/m)	Limit (dBµV/m)	Margin (dB)	Meas. Time (ms)	Bandwidth (kHz)	Height (cm)	Pol	Azimuth (deg)
9071.033333	---	38.15	60.00	21.85	1000.0	1000.000	105.0	H	294.0
14872.566667	53.94	---	80.00	26.06	1000.0	1000.000	215.0	H	189.0
16007.033333	55.46	---	80.00	24.54	1000.0	1000.000	303.0	H	291.0
16356.100000	56.39	---	80.00	23.61	1000.0	1000.000	275.0	V	204.0
16534.033333	56.48	---	80.00	23.52	1000.0	1000.000	125.0	H	55.0
16573.700000	---	43.20	60.00	16.80	1000.0	1000.000	275.0	H	291.0
16844.566667	54.77	---	80.00	25.23	1000.0	1000.000	127.0	H	153.0
16872.333333	55.41	---	80.00	24.59	1000.0	1000.000	276.0	V	63.0
17014.566667	55.54	---	80.00	24.46	1000.0	1000.000	175.0	H	0.0
17178.333333	53.99	---	80.00	26.01	1000.0	1000.000	205.0	V	181.0
17449.766667	54.87	---	80.00	25.13	1000.0	1000.000	125.0	V	28.0
17981.866667	---	44.30	60.00	15.70	1000.0	1000.000	313.0	V	0.0
17984.133333	56.95	---	80.00	23.05	1000.0	1000.000	114.0	H	198.0

The test report shall not be reproduced except in full without the written approval of the testing laboratory

7 Disclaimer

This document is issued by the Company subject to its General Conditions of Service (www.sgsgroup.de/agb). Attention is drawn to the limitations of liability, indemnification and jurisdictional issues established therein.

This document is an original. If the document is submitted digitally, it is to be treated as an original within the meaning of UCP 600.

Any holder of this document is advised that information contained hereon reflects the Company's findings at the time of its intervention only and within the limits of client's instructions, if any. The Company's sole responsibility is to its Client and this document does not exonerate parties to a transaction from exercising all their rights and obligations under the transaction documents. Any unauthorized alteration, forgery or falsification of the content or appearance of this document is unlawful and offenders may be prosecuted to the fullest extent of the law.

End of Test Report