

承 認 書

SPECIFICATION FOR APPROVAL

客 戶: CUSTOMER:	J026
客 戶 料 號: CUST P/N:	Y.45.TK00003
泛 亞 料 號: FINE P/N:	FYJ026001
產 品 型 號: DESC:	FYJ02612024070901L
日 期: DATE:	2024/07/09
版 本: Version:	A.0

CUSTOMER AUTHORIZED SIGNATURE/客户承认签核		

擬制 PREPARED BY	擬制 PREPARED BY	審核 CHECKED BY
尹 艺	蔡纪雨	



东莞市泛亚电子有限公司

Dongguan FANYA Electronics Co., LTD

地址：东莞市石碣镇刘屋科技东路 194 号

TEL: 0769-22490287 / 22452492

FAX: 0769-22499451

E-mail: fineelec@163.com

SPECIFICATION

產品型號: DESC	FYJ02612024070901L	版本 Rev: A.0	客戶 CUST:	J026
			泛亚料号 Fine P/N:	FYJ026001
			客戶料号 CUST P/N:	Y.45.TK00003

一、尺寸 DIMENSION:(mm)

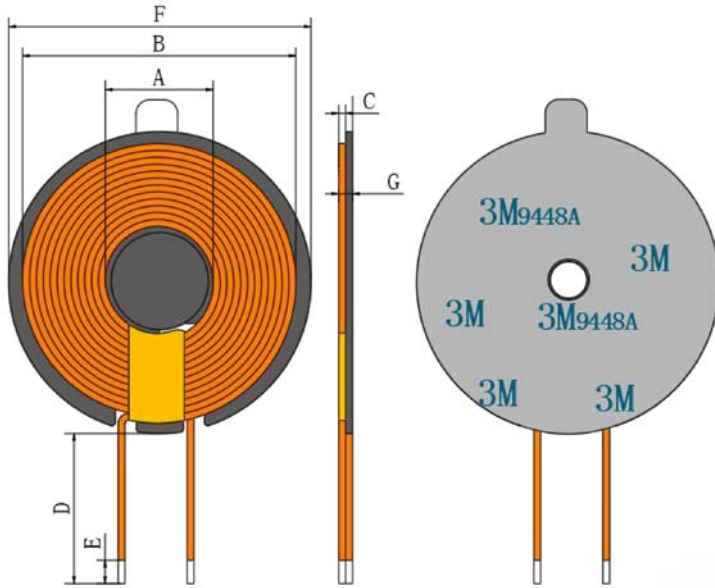

A	20.5±0.5
B	39.3±0.5
C	0.8±0.2
D	13±1.5
E	2-4
F	43.5±0.5
G	2.35 Max (不含离型纸及引线部分)

天线增益 Antenna gain:

Operation frequency:	113kHz-205kHz,360kHz
Antenna Type:	Loop coil Antenna
Antenna gain:	0dBi

二、原理图 SCHEMATIC DIAGRAM:

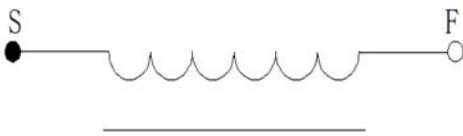

Note:

- 1.The lead does not need to be bent, and the starting wire is covered with 8mm wide high-temperature tape and 1.5Ts;
- 2.Coil backstick magnetic disc, magnetic disc size: $\varnothing 42 \times 6 \times 0.15$ mm 3M double-sided back tape hand tear
- 3.The middle of the coil is affixed with a small magnetic disc, the size of the small magnetic disc is 18×0.75 mm, and the small magnetic side is affixed with $\varnothing 15 \times 0.08$ ordinary double-sided adhesive
- 4.The coil fitting should be located in the center of ferrite, and the concentric circle deviation should not exceed 0.5mm

三、绕线参数 Winding Specification:

序号 NO.	端子 TERMINAL		线径 WIRE	圈数 Turns	绕线方向 Winding Direction
1	S	F	Litz0.08*65p	11Ts	CCW

四、电气特性 ELECTRICAL CHARACTERISTICS:

温度 TEMPERATURE:25±10°C, 湿度 RELATIVE HUMIDITY:65±20%

序号 NO.	项目 ITEM	端子 TERMINAL	标准 SPECIFICATION	测试条件 TEST FREQUENCY	测试仪器 TEST EQUIPMENTS
1	IND.	S-F	7.9uH ±5%	100KHz/1.0V	TH2810
2	DCR	S-F	≤ 70 mΩ	25°C	TH2810

擬制/日期 PREPARED BY/DATE	審核/日期 CHECKED BY/DATE	批准/日期 APPROVED BY/DATE
尹艺 2024/07/09	蔡纪雨 2024/07/09	

SPECIFICATION

產品型號: DESC	FYJ02612024070901L	版本 Rev: A.0	客戶 CUST:	J026
			泛亚料号 Fine P/N:	FYJ026001
			客户料号 CUST P/N:	Y.45.TK00003

五、包装 PACKONG:

5.1 包装图片 Packing pictures:

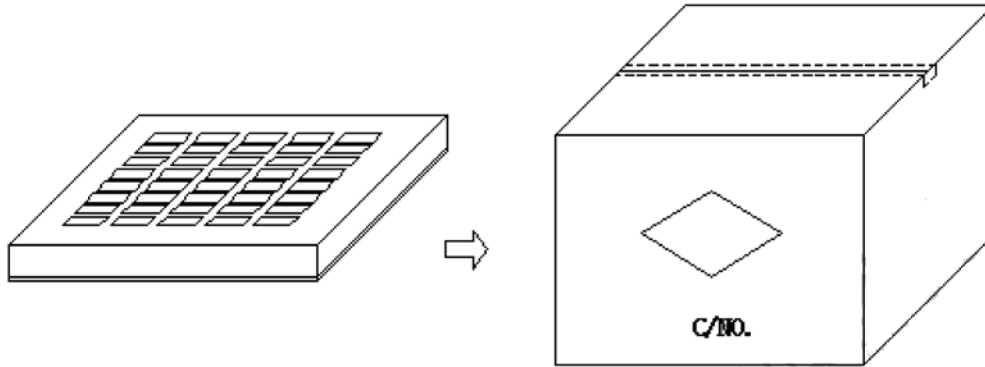

5.2 包装数量及规格 Packing Quantity:

项目 Item	数量 Quantity	材料规格 Material
盒 Box	200 Pcs	370*265*55mm
箱 Big Carton	1000 Pcs	420*270*310mm

5.3 包装以现有包装盘为参照标准，以实际出货包装为准,如有特需要求可以定制。

The packaging shall be based on the existing packing plate and the actual delivery package shall prevail. If there is any requirement, we can customize it.

六、材料清单 Material list:

序号 number	材料名称 Material name	品名描述 Description	制造商 Manufacturer
1	Litz0.08*65p	Litz0.08*65p	
2	无铅锡条	无铅锡条	Yuexing
3	磁片	φ 43.5*5.3*0.8mm, 开孔开 L 双槽	
4	小磁片	φ 18mm*0.75	
5	背胶	φ 42*6*0.15mm 3M 双面背胶带手撕位	
6	普通背胶	φ 15*0.08 带手撕位普通背胶	

擬制/日期 PREPARED BY/DATE	審核/日期 CHECKED BY/DATE	批准/日期 APPROVED BY/DATE
尹艺 2024/07/09	蔡纪雨 2024/07/09	