

# 承 認 書

## SPECIFICATION FOR APPROVAL

客 戶: CUSTOMER:	J026
客 戶 料 號: CUST P/N:	Y.45.TK00004
泛 亞 料 號: FINE P/N:	FYJ026002
產 品 型 號: DESC:	FYJ02612024070902L
日 期: DATE:	2024/07/09
版 本: Version:	A.0

<b>CUSTOMER AUTHORIZED SIGNATURE/客户承认签核</b>		

擬 制 PREPARED BY	審 核 CHECKED BY	批 准 APPROVED BY
尹 艺	蔡纪雨	



## 东莞市泛亚电子有限公司

Dongguan FANYA Electronics Co., LTD

地址：东莞市石碣镇刘屋科技东路 194 号

TEL: 0769-22490287 / 22452492

FAX: 0769-22499451

E-mail: fineelec@163.com



# SPECIFICATION

產品型號: DESC	<b>FYJ02612024070902L</b>	版本 Rev: A.0	客戶 CUST:	<b>J026</b>
			泛亚料号 Fine P/N:	<b>FYJ026002</b>
			客户料号 CUST P/N:	<b>Y.45.TK00004</b>

一、尺寸 DIMENSION:(mm)

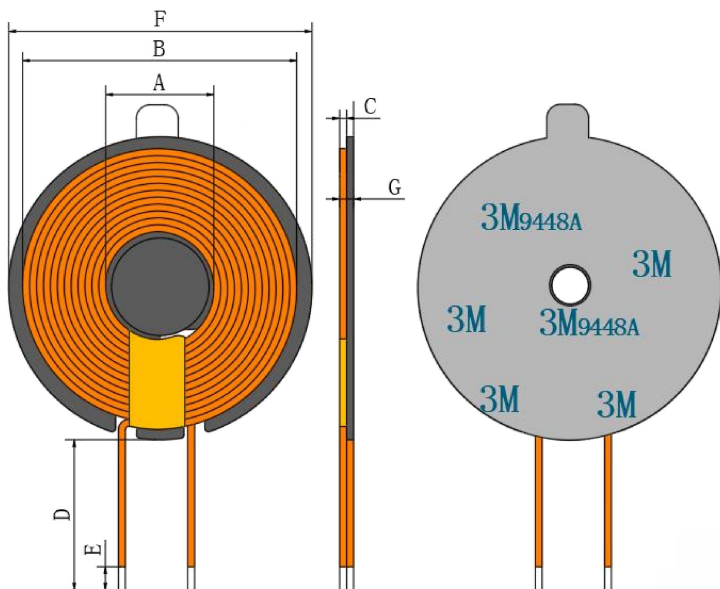

A	21.8±0.5
B	39±1
C	0.9±0.1
D	7±1
E	2-4
F	43.5±0.5
G	2.5 MAX (不含离型纸及引线部分)

Note:

1. Lead does not need to be bent; Starting wire package 8mm wide high-temperature tape, package 1.5TS;
2. Coil backstick magnetic disc, magnetic disc size:  $\varnothing 43.5 \times 5.3 \times 1.0$  Open hole open double slot. On the back,  $\varnothing 42 \times 6 \times 0.15$ mm 3m double-sided back tape is hand-torn 3. The middle of the coil is affixed with a small magnetic disc, the size of the small magnetic disc is  $20 \times 0.75$ mm, and the small magnetic side is affixed with  $\varnothing 15 \times 0.08$  ordinary double-sided adhesive.
4. The coil fitting should be located in the center of ferrite, and the concentric circle deviation should not exceed 0.5mm

二、原理图 SCHEMATIC DIAGRAM:

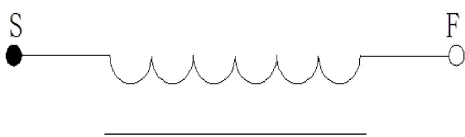

天线增益 Antenna gain:

Operation frequency:	113kHz-205kHz, 360kHz
Antenna Type:	Loop coil Antenna
Antenna gain:	0dBi

三、绕线参数 Winding Specification:

序号 NO.	端子 TERMINAL	线径 WIRE	圈数 Turns	绕线方向 Winding Direction
1	S F	Litz0.08*65p	11Ts	CCW

四、电气特性 ELECTRICAL CHARACTERISTICS:

温度 TEMPERATURE:  $25 \pm 10^\circ\text{C}$ , 湿度 RELATIVE HUMIDITY:  $65 \pm 20\%$

序号 NO.	项目 ITEM	端子 TERMINAL	标准 SPECIFICATION	测试条件 TEST FREQUENCY	测试仪器 TEST EQUIPMENTS
1	IND.	S-F	$8.5\mu\text{H} \pm 5\%$	100KHz/1.0V	TH2829LX
2	DCR	S-F	$70\text{m}\Omega$ Max	$25^\circ\text{C}$	TH2829LX

擬制/日期 PREPARED BY/DATE	審核/日期 CHECKED BY/DATE	批准/日期 APPROVED BY/DATE
尹艺 2024/07/09	蔡纪雨 2024/07/09	