

型号	YZXL50	客户	
		料号	

尺寸(mm)

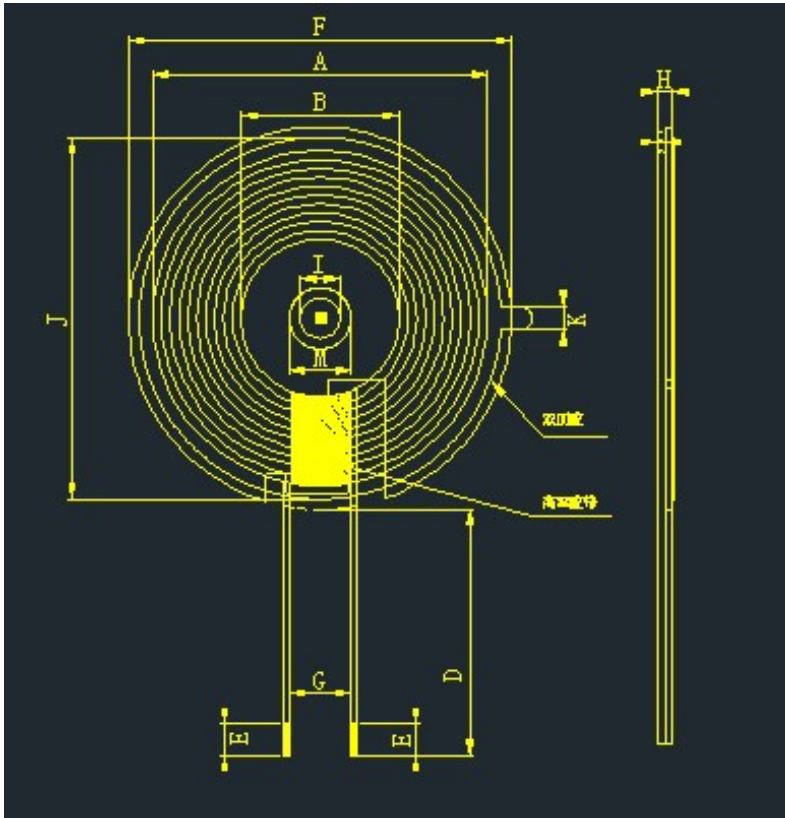

A	40.0±1.5
B	20.5±0.5
D	10±3
E	4±2
F	45±1.5
G	10.0±3
H	2.5Max
I	5.3 ±1.5
M	8.0 ±3
J	42±3
K	3.0±2

注:

1.具体参数以样品为准

天线增益 Antenna gain:

Operation frequency:	113kHz-205kHz
Antenna Type:	Loop coil Antenna
Antenna gain:	0dBi

绕线参数 Winding Specification:

序号	端子		线径	圈数	绕线方向
1	S	F	silk-covered copper wire 1.0±0.15	10Ts	CCW

四、电气特性 ELECTRICAL CHARACTERISTICS:

温度 TEMPERATURE:25±10°C, 湿度 RELATIVE HUMIDITY:65±20%

序号 NO.	项目 ITEM	端子 TERMINAL	标准 SPECIFICATION	测试条件 TEST FREQUENCY	测试仪器 TEST EQUIPMENTS
1	IND.	S-F	3.8uH ±20%	100KHz/1.0V	LCZ METER 1062B
2	IND.	S-F	6.3uH ±10% Magnetized sheet	100KHz/1.0V	LCZ METER 1062B
3	DCR	S-F	70≤mΩ		LCZ METER 502B