

SPECIFICATION

產品型號: DESC	φ 15x19.5-0.08x24-10mm-C	版本	客戶CUST:	
			客戶料号CUST P/N:	苹果手表线圈

一、尺寸DIMENSION:(mm)

Operating Frequency:300-500KHz
Gain:0 dBi

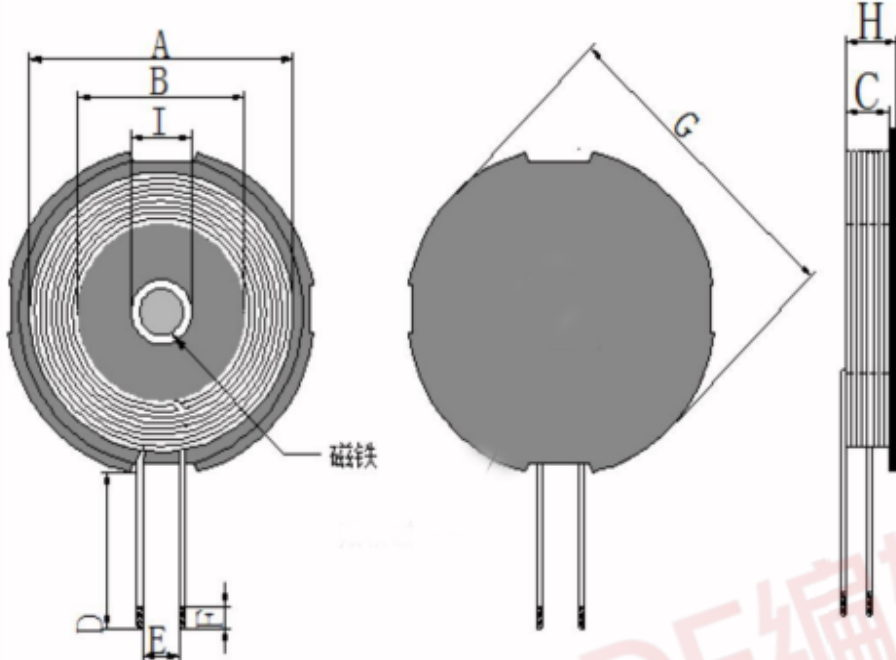

A	19.5±1.5
B	15±0.5
C	1.2±0.2
D	10±2
E	3ref
进锡F	6±2
G	24.5±1.0
H	2.8 Max
I	7.5±0.5

.....
 1.

 2. 7.5mm

 24.5mm 2.5±0.2mm

 3.

 7.5mm 2.5mm
 7.5*8 4000gs.

二、原理图SCHEMATIC DIAGRAM:

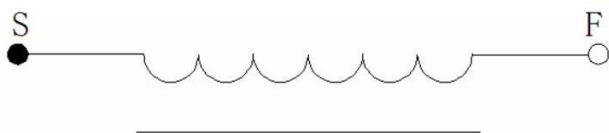

三、绕线参数Winding Specification:

序号 NO.	端子 TERMINAL		线径 WIRE	圈数 Turns	绕线方向 Winding Direction
1	S	F	0.08*24P	13Ts (ref)	CCW

四、电气特性ELECTRICAL CHARACTERISTICS:

温度TEMPERATURE:25±10°C, 湿度RELATIVE HUMIDITY:65±20%

序号 NO.	项目 ITEM	端子 TERMINAL	标准 SPECIFICATION	测试条件 TEST FREQUENCY.	测试仪器 TEST EQUIPMENTS.
1	INDUCT	S-F	7.5uH±10%带磁片	100KHZ/1V	LCZ METER 1061A

擬制/日期PREPARED BY/DATE	審核/日期CHECKED BY/DATE
• • 2024/08/22	• • • 2024/08/22