



TEST REPORT

Product Name : Qi2 3 in 1 Foldable wireless charger
Brand Name : N/A
Model : TKWC-052
Series Model : TKWC-052Q,TKWC-052C,27676
FCC ID : 2AV8L-TKWC-052
Applicant : **TANKYA DEVELOPING CO., LIMITED**
Address : 6F, B Building of Tengyao Technology Park, 2nd Gushu Road,
Xixiang, Baoan, Shenzhen, China
Manufacturer : **Shenzhen Powerqi Technology Co.,Ltd.**
Address : Room 901, Building 5, 10th Industrial Zone, Tianliao Community,
Yutang Street, Guangming District, Shenzhen, 518127,
Guangdong, China
Standard(s) : FCC CFR Title 47 Part 15 Subpart C
Date of Receipt : Aug.02, 2024
Date of Test : Aug.02, 2024~ Aug.07, 2024
Issued Date : Aug.07, 2024

Issued By: **Guangdong Asia Hongke Test Technology Limited**
B1/F, Building 11, Junfeng Industrial Park, Chongqing Road, Heping Community, Fuhai Street,
Bao'an District, Shenzhen, Guangdong, China
Tel.: +86 0755-230967639 Fax.: +86 0755-230967639

Reviewed by: 
Leon.yi

Approved by: 
Sean She



Note: This device has been tested and found to comply with the standard(s) listed, this test report merely corresponds to the test sample. It is not permitted to copy extracts of these test result without the written permission of the test laboratory. This report shall not be reproduced except in full, without the written approval of Guangdong Asia Hongke Test Technology Limited. If there is a need to alter or revise this document, the right belongs to Guangdong Asia Hongke Test Technology Limited, and it should give a prior written notice of the revision document. This test report must not be used by the client to claim product endorsement.



Report Revise Record

Report Version	Issued Date	Notes
M1	Aug.07, 2024	Initial Release

Contents

1	TEST SUMMARY.....	4
1.1	TEST STANDARDS	4
1.2	TEST SUMMARY	4
1.3	TEST FACILITY	5
1.4	MEASUREMENT UNCERTAINTY	5
2	GENGENERAL INFORMATION	6
2.1	ENVIRONMENTAL CONDITIONS	6
2.2	GENERAL DESCRIPTION OF EUT	6
2.3	DESCRIPTION OF THE TEST MODE	7
2.4	SPECIAL ACCESSORIES	7
2.5	EQUIPMENT LIST FOR THE TEST	8
3	TEST CONDITIONS AND RESULTS	9
3.1	CONDUCTED EMISSIONS TEST	9
3.2	RADIATED EMISSIONS.....	12
3.3	20dB BANDWIDTH.....	20
3.4	ANTENNA REQUIREMENT.....	23
4	TEST SETUP PHOTOGRAPHS OF EUT	24
5	EXTERNAL PHOTOGRAPHS OF EUT	24
6	INTERNAL PHOTOGRAPHS OF EUT	24

1 TEST SUMMARY

1.1 Test Standards

The tests were performed according to following standards:

[FCC Rules Part 15.207,15.209, 15.215\(c\)](#)

[ANSI C63.10: 2013](#): American National Standard for Testing Unlicensed Wireless Devices

1.2 Test Summary

Test Item	Section in CFR 47	Test Result
Electric Field Radiated Emissions	FCC Part 15 C (Section15.209)	PASS
20dB Bandwidth/99% Bandwidth	FCC Part 15 C (Section15.215(c))	PASS
AC Power Line Conducted Emission	FCC Part 15 C (Section15.207)	PASS
Antenna Requirement	FCC Part 15 C (Section15.203)	PASS

1.3 Test Facility

Test Laboratory:

Guangdong Asia Hongke Test Technology Limited

B1/F, Building 11, Junfeng Industrial Park, Chongqing Road, Heping Community, Fuhai Street, Bao'an District, Shenzhen, Guangdong, China

The test facility is recognized, certified or accredited by the following organizations:

FCC-Registration No.: 251906 Designation Number: CN1376

Guangdong Asia Hongke Test Technology Limited has been registered and fully described in a report filed with the (FCC) Federal Communications Commission. The acceptance letter from the FCC is maintained in our files.

IC —Registration No.: 31737 CAB identifier: CN0165

The 3m Semi-anechoic chamber of Guangdong Asia Hongke Test Technology Limited has been registered by Certification and Engineering Bureau of Industry Canada for radio equipment testing with Registration No.: 31737

A2LA-Lab Cert. No.: 7133.01

Guangdong Asia Hongke Test Technology Limited has been accredited by A2LA for technical competence in the field of electrical testing, and proved to be in compliance with ISO/IEC 17025: 2017 General Requirements for the Competence of Testing and Calibration Laboratories and any additional program requirements in the identified field of testing.

1.4 Measurement uncertainty

The data and results referenced in this document are true and accurate. The reader is cautioned that there may be errors within the calibration limits of the equipment and facilities. The measurement uncertainty was calculated for all measurements listed in this test report according to CISPR 16 - 4 “Specification for radio disturbance and immunity measuring apparatus and methods – Part 4: Uncertainty in EMC Measurements” and is documented in the Guangdong Asia Hongke Test Technology Limited’s quality system according to DIN EN ISO/IEC 17025. Furthermore, component and process variability of devices similar to that tested may result in additional deviation. The manufacturer has the sole responsibility of continued compliance of the device.

Hereafter the best measurement capability for Asia Hongke laboratory is reported:

Test	Measurement Uncertainty	Notes
Power Line Conducted Emission	150KHz~30MHz ±1.20 dB	(1)
Radiated Emission	9KHz~30Hz ±3.10dB	(1)
Radiated Emission	9KHz~1GHz ±3.75dB	(1)
Radiated Emission	1GHz~18GHz ±3.88 dB	(1)
Radiated Emission	18GHz-40GHz ±3.88dB	(1)
RF power, conducted	30MHz~6GHz ±0.16dB	(1)
RF power density, conducted	±0.24dB	(1)
Spurious emissions, conducted	±0.21dB	(1)
Temperature	±1°C	(1)
Humidity	±3%	(1)
DC and low frequency voltages	±1.5%	(1)
Time	±2%	(1)
Duty cycle	±2%	(1)

The report uncertainty of measurement $y \pm U$, where expanded uncertainty U is based on a standard uncertainty Multiplied by a coverage factor of $k=2$, providing a level of confidence of approximately 95%

2 GENGENERAL INFORMATION

2.1 Environmental conditions

During the measurement the environmental conditions were within the listed ranges:

Normal Temperature:	25°C
Relative Humidity:	55 %
Air Pressure:	101 kPa

2.2 General Description of EUT

Product Name:	Qi2 3 in 1 Foldable wireless charger
Model/Type reference:	TKWC-052
Power Supply:	Input: DC12V=3A,15V=2.33A Output1: 5W, 7.5W, 10W, 15W(Phone) Output2: 2.5W(Apple Watch) Output3: 5W(AirPods)
Hardware version:	V10
Software version:	V1.0
Sample(s) Status:	AiTSZ-240802003-01(Normal sample) AiTSZ-240802003-02(Engineer sample)
Wireless Charger:	
Operation frequency:	Coil1: For Phone: 113kHz-205kHz, 360KHZ Coil2: For Earphone: 113kHz-205kHz Coil3: Watch: 300kHz-350kHz
Modulation Technology:	ASK
Antenna Type:	Loop coil Antenna
Antenna gain:	0dBi
Remark: The above DUT's information was declared by manufacturer. For more detailed features description, please refer to the manufacturer's specifications or the User's Manual.	

2.3 Description of the test mode

Equipment under test was operated during the measurement under the following conditions:

- Charging and communication mode

Test Modes:		
Mode 1	AC Adapter + EUT + Earphone + Watch + Phone (Battery Status: < 1%)	Record
Mode 2	AC Adapter + EUT + Earphone + Watch + Phone (Battery Status: < 50%)	Pre-tested
Mode 3	AC Adapter + EUT + Earphone + Watch + Phone (Battery Status: < 99%)	Pre-tested
Mode 4	AC Adapter + EUT + Earphone+ Phone (Battery Status: < 1%)	Pre-tested
Mode 5	AC Adapter + EUT + Earphone+ Phone (Battery Status: < 50%)	Pre-tested
Mode 6	AC Adapter + EUT + Earphone+ Phone (Battery Status: < 99%)	Pre-tested
Mode 7	AC Adapter + EUT + Watch + Phone (Battery Status: < 1%)	Pre-tested
Mode 8	AC Adapter + EUT + Watch + Phone (Battery Status: < 50%)	Pre-tested
Mode 9	AC Adapter + EUT + Watch + Phone (Battery Status: < 99%)	Pre-tested
Mode 11	AC Adapter + EUT + Earphone + Watch	Pre-tested
Mode 12	AC Adapter + EUT + Earphone	Pre-tested
Mode 13	AC Adapter + EUT + Watch	Pre-tested
Mode 14	AC Adapter + EUT+ Phone (Battery Status: < 1%)	Pre-tested
Mode 15	AC Adapter + EUT+ Phone (Battery Status: < 50%)	Pre-tested
Mode 16	AC Adapter + EUT+ Phone (Battery Status: < 99%)	Pre-tested
Mode 17	Stand-by mode.	Pre-tested

Note: All test modes were pre-tested, but we only recorded the worst case in this report.

2.4 Special Accessories

Follow auxiliary equipment(s) test with EUT that provided by the manufacturer or laboratory is listed as follow:

Description	Manufacturer	Model	Serial No.	Provided by	Other
Adapter	HNT	HNT-QC530	/	Test lab	/
Phone	YBZ	15W	/	Test lab	/
Phone	Apple	iphone 14	/	Test lab	15W
Watch	Apple	S6	/	Test lab	/
Earphone	PocBuds	K6	/	Test lab	/

2.5 Equipment List for the Test

No	Test Equipment	Manufacturer	Model No	Serial No	Cal. Date	Cal. Due Date
1	Spectrum Analyzer	R&S	FSV40	101470	2023.09.08	2024.09.07
2	Spectrum Analyzer	Keysight	N9020A	MY51280643	2023.09.08	2024.09.07
3	EMI Measuring Receiver	R&S	ESR	101660	2023.09.08	2024.09.07
4	Low Noise Pre-Amplifier	HP	HP8447E	1937A01855	2023.09.08	2024.09.07
5	Low Noise Pre-Amplifier	Tsj	MLA-0120-A02-34	2648A04738	2023.09.08	2024.09.07
6	Passive Loop	ETS	6512	00165355	2022.09.04	2024.09.03
7	TRILOG Super Broadband test Antenna	SCHWARZBECK	VULB9160	9160-3206	2021.08.29	2024.08.28
8	Broadband Horn Antenna	SCHWARZBECK	BBHA9120D	452	2021.08.29	2024.08.28
9	SHF-EHF Horn Antenna 15-40GHz	SCHWARZBECK	BBHA9170	BBHA9170367d	2021.08.29	2024.08.28
10	EMI Measuring Receiver	R&S	ESR	101160	2023.09.13	2024.09.12
11	LISN	SCHWARZBECK	NNLK 8129	8130179	2023.10.29	2024.10.28
12	Pulse Limiter	R&S	ESH3-Z2	102789	2023.09.13	2024.09.12
13	Pro.Temp&Humi.chamber	MENTEK	MHP-150-1C	MAA08112501	2023.09.08	2024.09.07
14	RF Automatic Test system	MW	MW100-RFCB	21033016	2023.09.08	2024.09.07
15	Signal Generator	Agilent	N5182A	MY50143009	2023.09.08	2024.09.07
16	Wideband Radio communication tester	R&S	CMW500	1201.0002K50	2023.09.08	2024.09.07
17	RF Automatic Test system	MW	MW100-RFCB	21033016	2023.09.08	2024.09.07
18	DC power supply	ZHAOXIN	RXN-305D-2	28070002559	N/A	N/A
19	RE Software	EZ	EZ-EMC_RE	Ver.AIT-03A	N/A	N/A
20	CE Software	EZ	EZ-EMC_CE	Ver.AIT-03A	N/A	N/A
21	RF Software	MW	MTS 8310	2.0.0.0	N/A	N/A
22	temporary antenna connector(Note)	NTS	R001	N/A	N/A	N/A

Note: The temporary antenna connector is soldered on the PCB board in order to perform conducted tests and this temporary antenna connector is listed in the equipment list.

3 TEST CONDITIONS AND RESULTS

3.1 Conducted Emissions Test

LIMIT

Frequency range (MHz)	Limit (dBuV)	
	Quasi-peak	Average
0.15-0.5	66 to 56*	56 to 46*
0.5-5	56	46
5-30	60	50

* Decreases with the logarithm of the frequency.

TEST CONFIGURATION

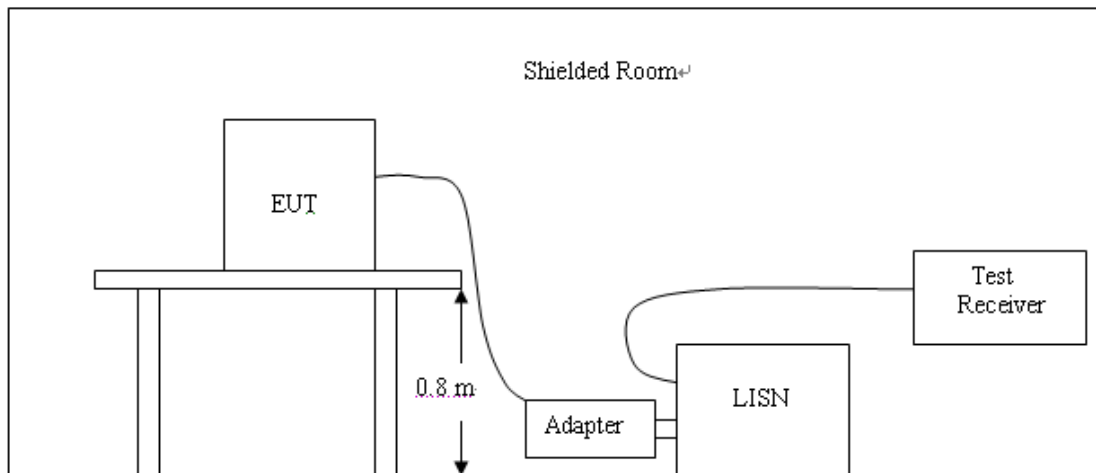

TEST PROCEDURE

1. The equipment was set up as per the test configuration to simulate typical actual usage per the user’s manual. The EUT is a tabletop system; a wooden table with a height of 0.8 meters is used and is placed on the ground plane as per ANSI C63.10:2013.
2. Support equipment, if needed, was placed as per ANSI C63.10:2013.
3. All I/O cables were positioned to simulate typical actual usage as per ANSI C63.10:2013.
4. The adapter received AC120V/60Hz power through a Line Impedance Stabilization Network (LISN) which supplied power source and was grounded to the ground plane.
5. All support equipments received AC power from a second LISN, if any.
6. The EUT test program was started. Emissions were measured on each current carrying line of the EUT using a spectrum Analyzer / Receiver connected to the LISN powering the EUT. The LISN has two monitoring points: Line 1 (Hot Side) and Line 2 (Neutral Side). Two scans were taken: one with Line 1 connected to Analyzer / Receiver and Line 2 connected to a 50 ohm load; the second scan had Line 1 connected to a 50 ohm load and Line 2 connected to the Analyzer / Receiver.
7. Analyzer / Receiver scanned from 150 KHz to 30MHz for emissions in each of the test modes.
8. During the above scans, the emissions were maximized by cable manipulation.

TEST RESULTS

Remark:

1. Both 120 VAC, 50/60 Hz and 240 VAC, 50/60 Hz power supply have been tested, only the worst result of 120 VAC, 60 Hz was reported as below:

2. Test phone coil can be working on EPP and MPP mode, only the worst result with phone coil working at EPP Mode recorded as below:

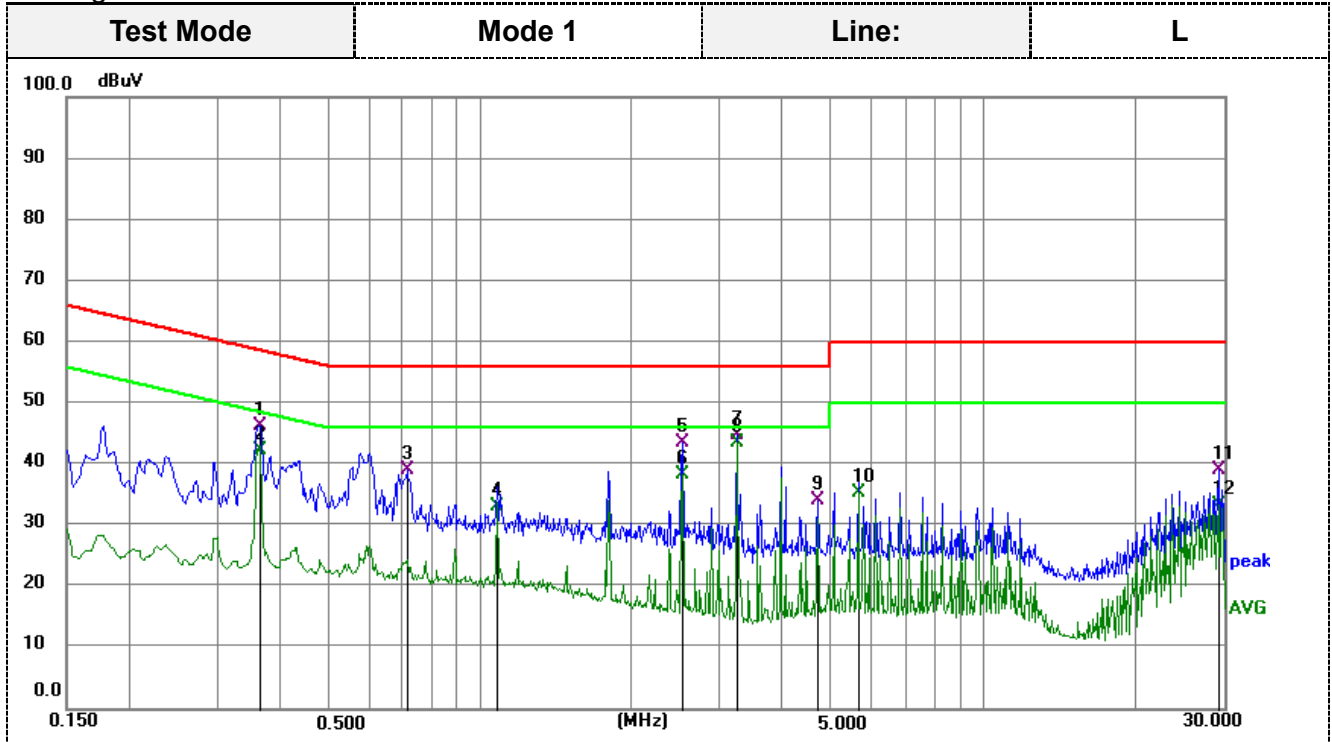

Remark: Correct Factor = Insertion loss of LISN + Cable loss + Insertion loss of Pulse Limiter;
 Measurement Result = Reading Level +Correct Factor;
 Margin = Measurement Result- Limit

No.	Frequency (MHz)	Reading (dBuV)	Correct (dB)	Result (dBuV)	Limit (dBuV)	Margin (dB)	Remark
1	0.3615	35.68	10.69	46.37	58.69	-12.32	QP
2	0.3615	31.56	10.69	42.25	48.69	-6.44	AVG
3	0.7125	28.32	10.67	38.99	56.00	-17.01	QP
4	1.0770	22.45	10.66	33.11	46.00	-12.89	AVG
5	2.5170	32.85	10.79	43.64	56.00	-12.36	QP
6	2.5170	27.62	10.79	38.41	46.00	-7.59	AVG
7	3.2370	34.05	10.83	44.88	56.00	-11.12	QP
8	3.2370	32.75	10.83	43.58	46.00	-2.42	AVG
9	4.6725	23.16	11.01	34.17	56.00	-21.83	QP
10	5.6310	24.30	11.03	35.33	50.00	-14.67	AVG
11	29.4810	27.27	11.72	38.99	60.00	-21.01	QP
12	29.4810	21.73	11.72	33.45	50.00	-16.55	AVG

Test Mode	Mode 1	Line:	N
-----------	--------	-------	---

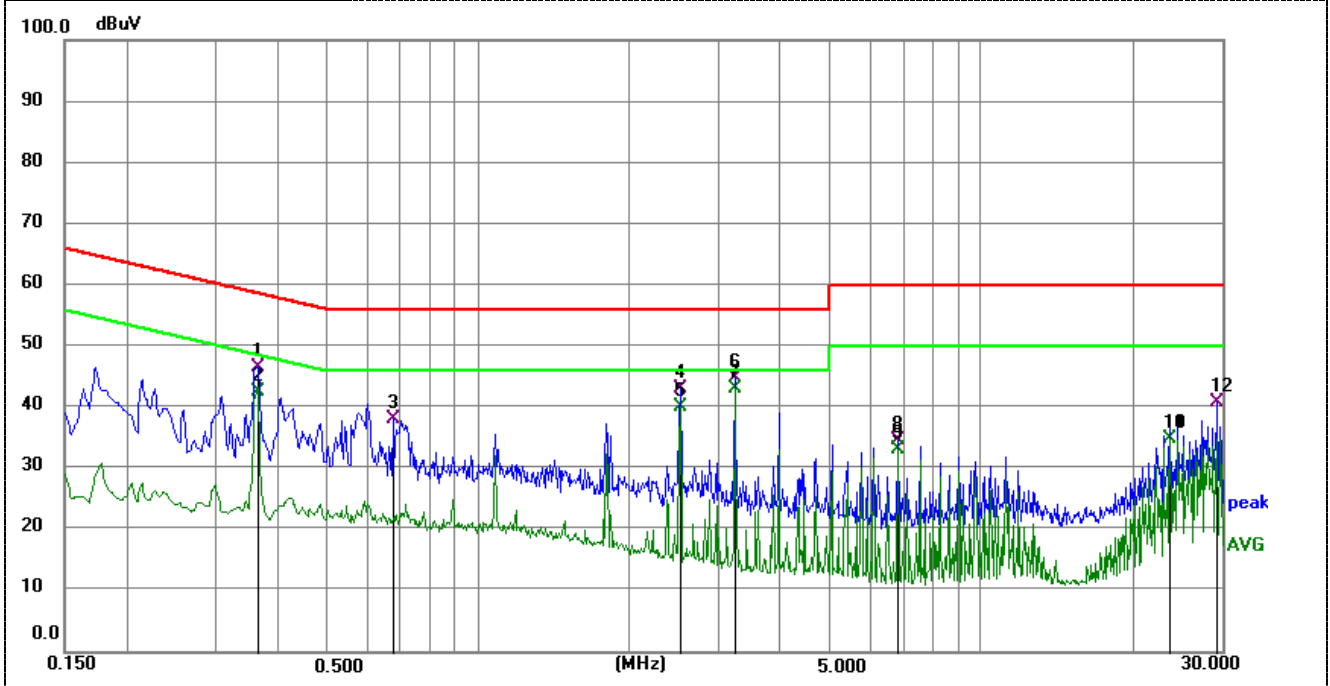

Remark: Correct Factor = Insertion loss of LISN + Cable loss + Insertion loss of Pulse Limiter;
 Measurement Result = Reading Level + Correct Factor;

Margin = Measurement Result - Limit

No.	Frequency (MHz)	Reading (dBuV)	Correct (dB)	Result (dBuV)	Limit (dBuV)	Margin (dB)	Remark
1	0.3615	35.76	10.68	46.44	58.69	-12.25	QP
2	0.3615	31.86	10.68	42.54	48.69	-6.15	AVG
3	0.6765	27.38	10.67	38.05	56.00	-17.95	QP
4	2.5170	32.17	10.78	42.95	56.00	-13.05	QP
5	2.5170	29.31	10.78	40.09	46.00	-5.91	AVG
6	3.2370	34.05	10.82	44.87	56.00	-11.13	QP
7	3.2370	32.23	10.82	43.05	46.00	-2.95	AVG
8	6.8325	23.62	11.03	34.65	60.00	-25.35	QP
9	6.8325	22.11	11.03	33.14	50.00	-16.86	AVG
10	23.7300	23.21	11.68	34.89	50.00	-15.11	AVG
11	23.7300	23.21	11.68	34.89	50.00	-15.11	AVG
12	29.4810	29.26	11.61	40.87	60.00	-19.13	QP

3.2 Radiated Emissions

Limit

For intentional device, according to § 15.209(a), the general requirement of field strength of radiated emission out of authorized band shall not exceed the following table at a 3 meters measurement distance.

In addition, radiated emissions which fall in the restricted bands, as defined in §15.205(a), must also comply with the radiated emission limits specified in §15.209(a)

Radiated emission limits

Frequency (MHz)	Distance (Meters)	Radiated (dBµV/m)	Radiated (µV/m)
0.009-0.49	3	$20\log(2400/F(\text{KHz}))+40\log(300/3)$	$2400/F(\text{KHz})$
0.49-1.705	3	$20\log(24000/F(\text{KHz}))+40\log(30/3)$	$24000/F(\text{KHz})$
1.705-30	3	$20\log(30)+40\log(30/3)$	30
30-88	3	40.0	100
88-216	3	43.5	150
216-960	3	46.0	200
Above 960	3	54.0	500

TEST CONFIGURATION

(A) Radiated Emission Test Set-Up, Frequency Below 30MHz

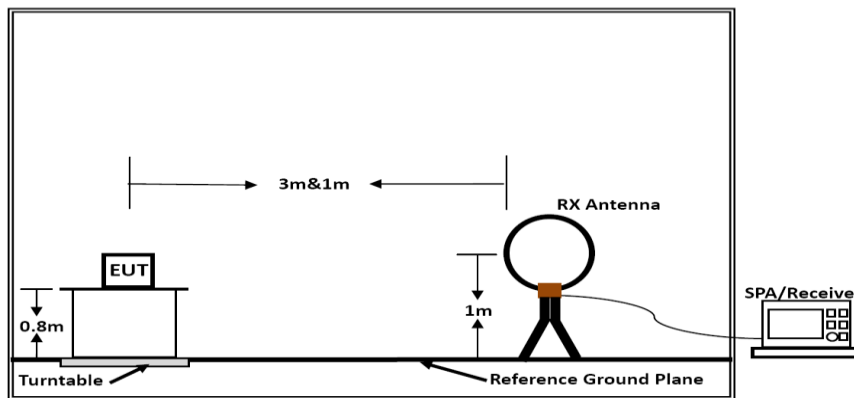

Below 30MHz

(B) Radiated Emission Test Set-Up, Frequency below 1000MHz

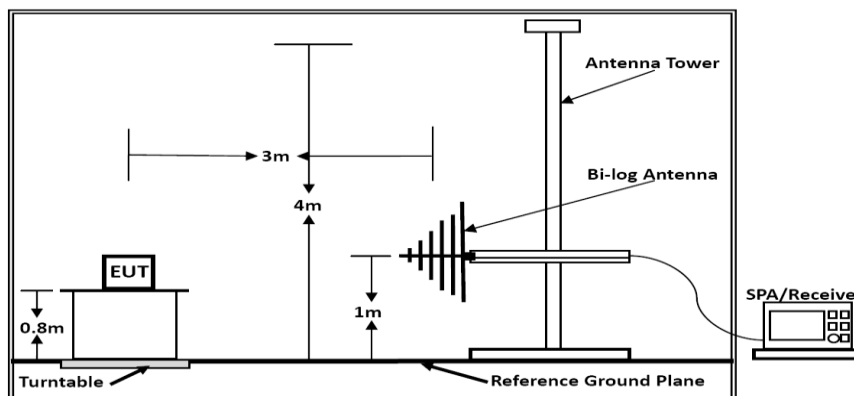

Below 1GHz

(C) Radiated Emission Test Set-Up, Frequency above 1000MHz

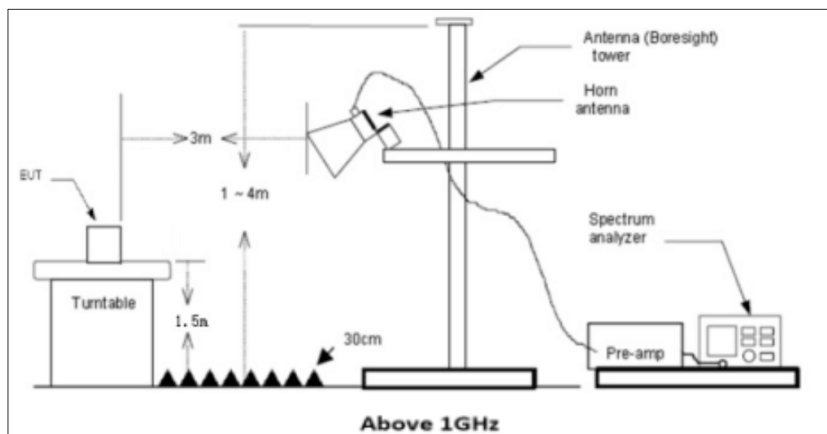

Test Procedure

1. Below 1GHz measurement the EUT is placed on a turntable which is 0.8m above ground plane, and above 1GHz measurement EUT was placed on a low permittivity and low loss tangent turn table which is 1.5m above ground plane.
2. Maximum procedure was performed by raising the receiving antenna from 1m to 4m and rotating the turn table from 0° to 360° to acquire the highest emissions from EUT
3. And also, each emission was to be maximized by changing the polarization of receiving antenna both horizontal and vertical.
4. Repeat above procedures until all frequency measurements have been completed.
5. Radiated emission test frequency band from 9KHz to 1000MHz.
6. The distance between test antenna and EUT as following table states:

Test Frequency range	Test Antenna Type	Test Distance
9KHz-30MHz	Active Loop Antenna	3
30MHz-1GHz	Bilog Antenna	3

7. Setting test receiver/spectrum as following table states:

Test Frequency range	Test Receiver/Spectrum Setting	Detector
9KHz-150KHz	RBW=200Hz/VBW=3KHz,Sweep time=Auto	QP
150KHz-30MHz	RBW=9KHz/VBW=100KHz,Sweep time=Auto	QP
30MHz-1GHz	RBW=120KHz/VBW=1000KHz,Sweep time=Auto	QP

TEST RESULTS

Remark:

1. All test modes described in section 2.3 has been tested, only the worst result of Mode 1 is recorded as below:
2. Test result for 30MHz -1GHz only show the worst case of phone coil working on EPP mode.

For 9KHz-150KHz

(Phone Frequency:113-205KHz, Earphone Frequency:113-205KHz, Watch Frequency:300-350KHz)

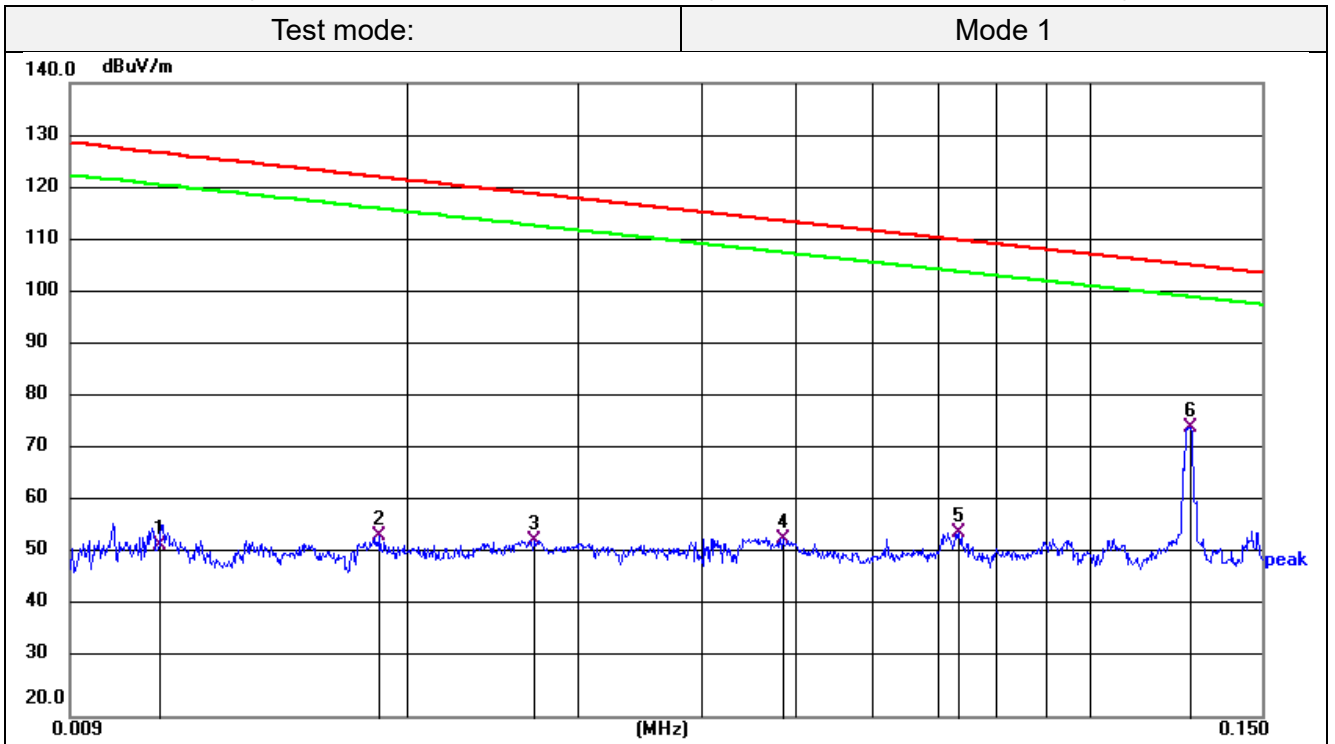

Remark:

Emission Level = Reading + Factor;
 Factor = Antenna Factor + Cable Loss;
 Margin= Emission Level - Limit.

No.	Frequency (MHz)	Reading (dBuV)	Factor (dB/m)	Level (dBuV/m)	Limit (dBuV/m)	Margin (dB)	Det.
1	0.0111	31.25	21.36	52.61	126.70	-74.09	QP
2	0.0187	33.39	20.88	54.27	122.17	-67.90	QP
3	0.0270	32.22	21.22	53.44	118.98	-65.54	QP
4	0.0483	31.22	22.50	53.72	113.93	-60.21	QP
5	0.0734	32.12	22.68	54.80	110.29	-55.49	QP
6	0.1267	52.64	22.13	74.77	105.55	-30.78	QP

For 150KHz-30MHz

(Phone Frequency:113-205KHz, Earphone Frequency:113-205KHz, Watch Frequency:300-350KHz)

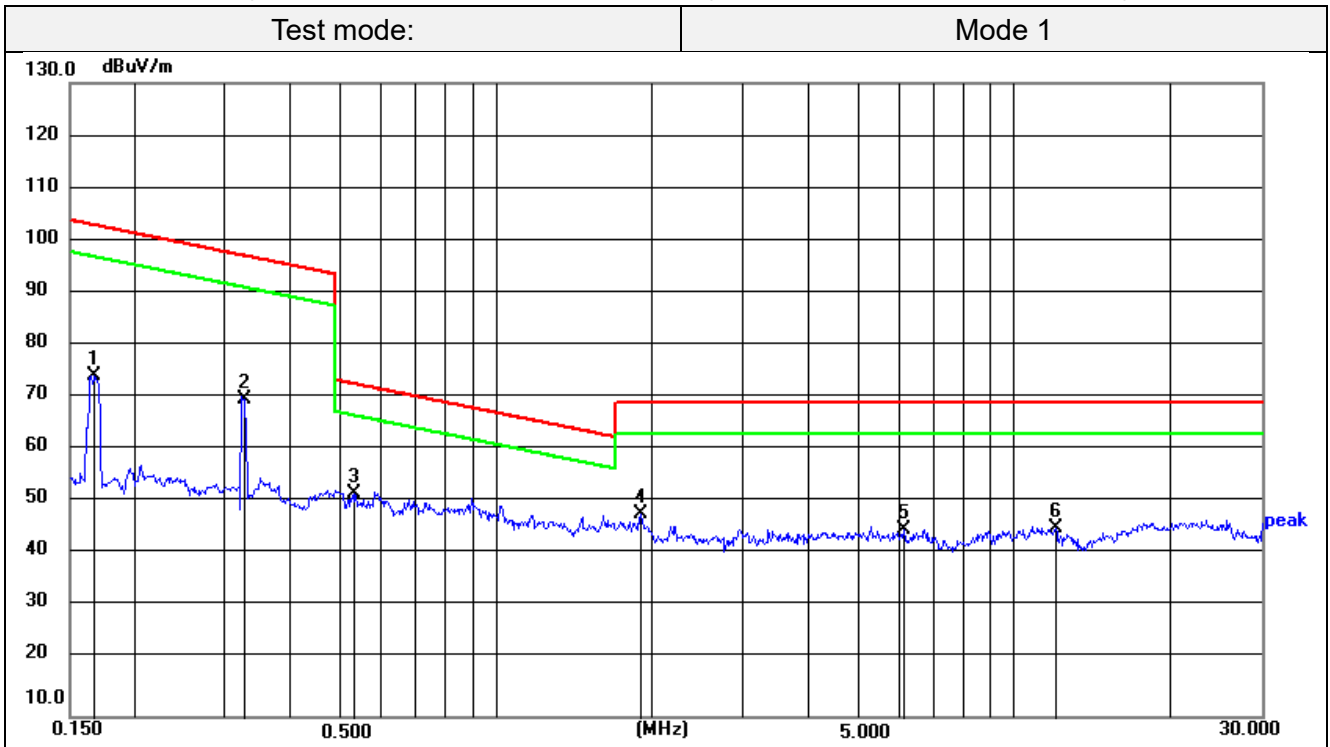

Remark:
 Emission Level = Reading + Factor;
 Factor = Antenna Factor + Cable Loss;
 Margin= Emission Level - Limit.

No.	Frequency (MHz)	Reading (dBuV)	Factor (dB/m)	Level (dBuV/m)	Limit (dBuV/m)	Margin (dB)	Det.
1	0.1675	52.75	21.81	74.56	103.12	-28.56	QP
2	0.3251	48.73	21.52	70.25	97.36	-27.11	QP
3	0.5321	30.33	21.89	52.22	73.08	-20.86	QP
4	1.8980	26.18	22.42	48.60	69.54	-20.94	QP
5	6.1208	22.25	23.14	45.39	69.54	-24.15	QP
6	11.9961	22.92	23.00	45.92	69.54	-23.62	QP

For 9KHz-150KHz

(Phone Frequency:360KHz, Earphone Frequency:113-205KHz, Watch Frequency:300-350KHz)

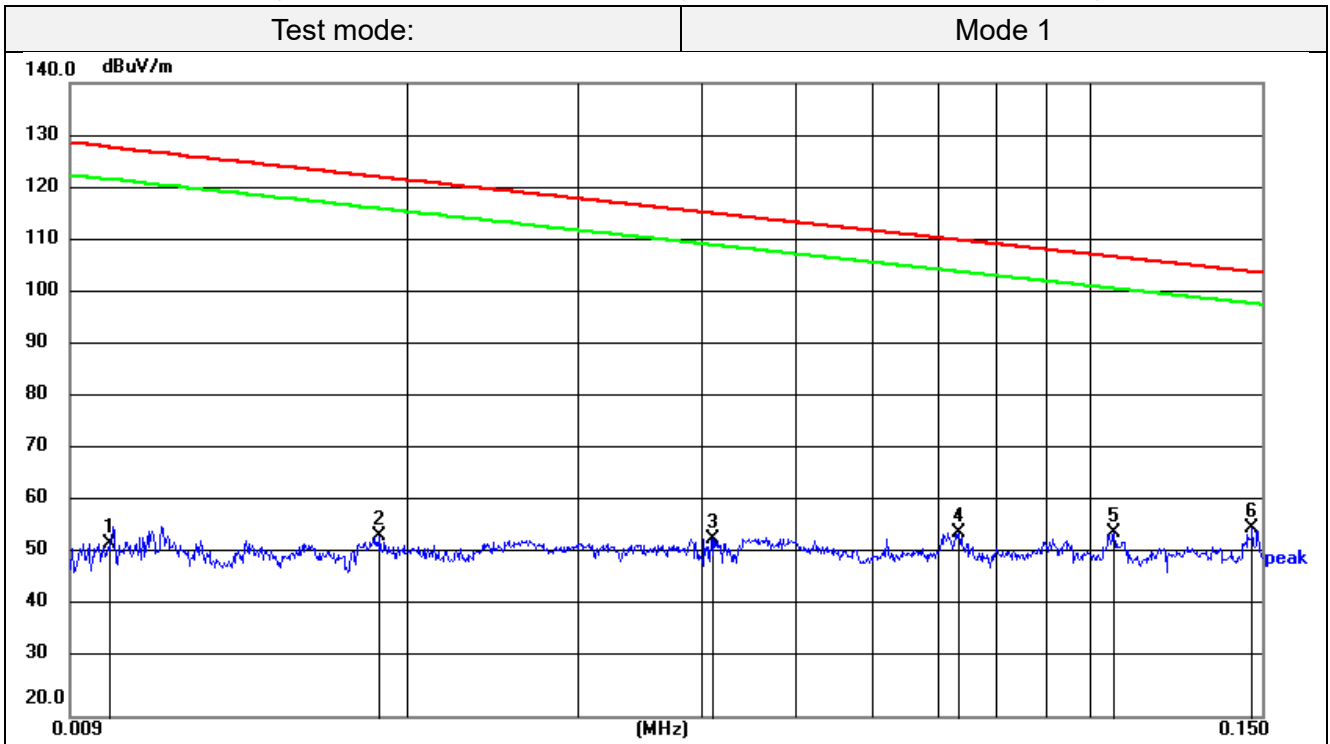

Remark:

Emission Level = Reading + Factor;
 Factor = Antenna Factor + Cable Loss;
 Margin= Emission Level - Limit.

No.	Frequency (MHz)	Reading (dBuV)	Factor (dB/m)	Level (dBuV/m)	Limit (dBuV/m)	Margin (dB)	Det.
1	0.0100	31.28	21.43	52.71	127.60	-74.89	QP
2	0.0187	33.39	20.88	54.27	122.17	-67.90	QP
3	0.0410	31.58	22.06	53.64	115.35	-61.71	QP
4	0.0734	32.12	22.68	54.80	110.29	-55.49	QP
5	0.1058	32.46	22.34	54.80	107.11	-52.31	QP
6	0.1466	33.85	21.93	55.78	104.28	-48.50	QP

For 150KHz-30MHz

(Phone Frequency:360KHz, Earphone Frequency:113-205KHz, Watch Frequency:300-350KHz)



Remark:

Emission Level = Reading + Factor;
 Factor = Antenna Factor + Cable Loss;
 Margin = Emission Level - Limit.

No.	Frequency (MHz)	Reading (dBuV)	Factor (dB/m)	Level (dBuV/m)	Limit (dBuV/m)	Margin (dB)	Det.
1	0.1675	52.75	21.81	74.56	103.12	-28.56	QP
2	0.3600	52.50	21.58	74.08	96.48	-22.40	QP
3	0.3251	48.23	21.52	69.75	97.36	-27.61	QP
4	0.8044	26.99	22.52	49.51	69.49	-19.98	QP
5	1.8980	26.18	22.42	48.60	69.54	-20.94	QP
6	5.7134	21.48	23.20	44.68	69.54	-24.86	QP

For 30MHz-1GHz

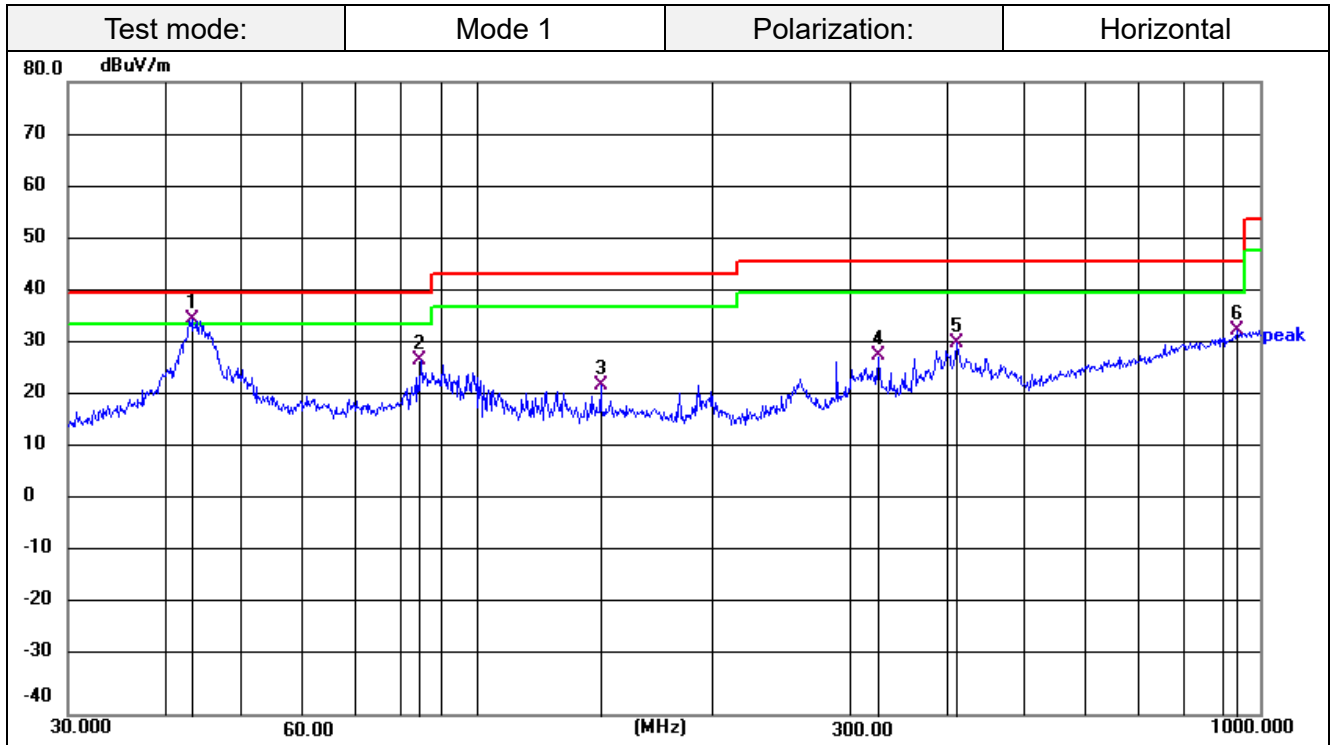

Remark:

Emission Level = Reading + Factor;
 Factor = Antenna Factor + Cable Loss – Pre-amplifier;
 Margin= Emission Level - Limit.

No.	Frequency (MHz)	Reading (dBuV)	Factor (dB/m)	Level (dBuV/m)	Limit (dBuV/m)	Margin (dB)	Det.
1	43.2017	51.54	-16.62	34.92	40.00	-5.08	QP
2	84.7019	48.37	-20.96	27.41	40.00	-12.59	QP
3	143.8295	39.40	-17.00	22.40	43.50	-21.10	QP
4	325.5958	44.23	-16.21	28.02	46.00	-17.98	QP
5	410.3824	44.92	-14.29	30.63	46.00	-15.37	QP
6	935.5463	36.92	-3.90	33.02	46.00	-12.98	QP

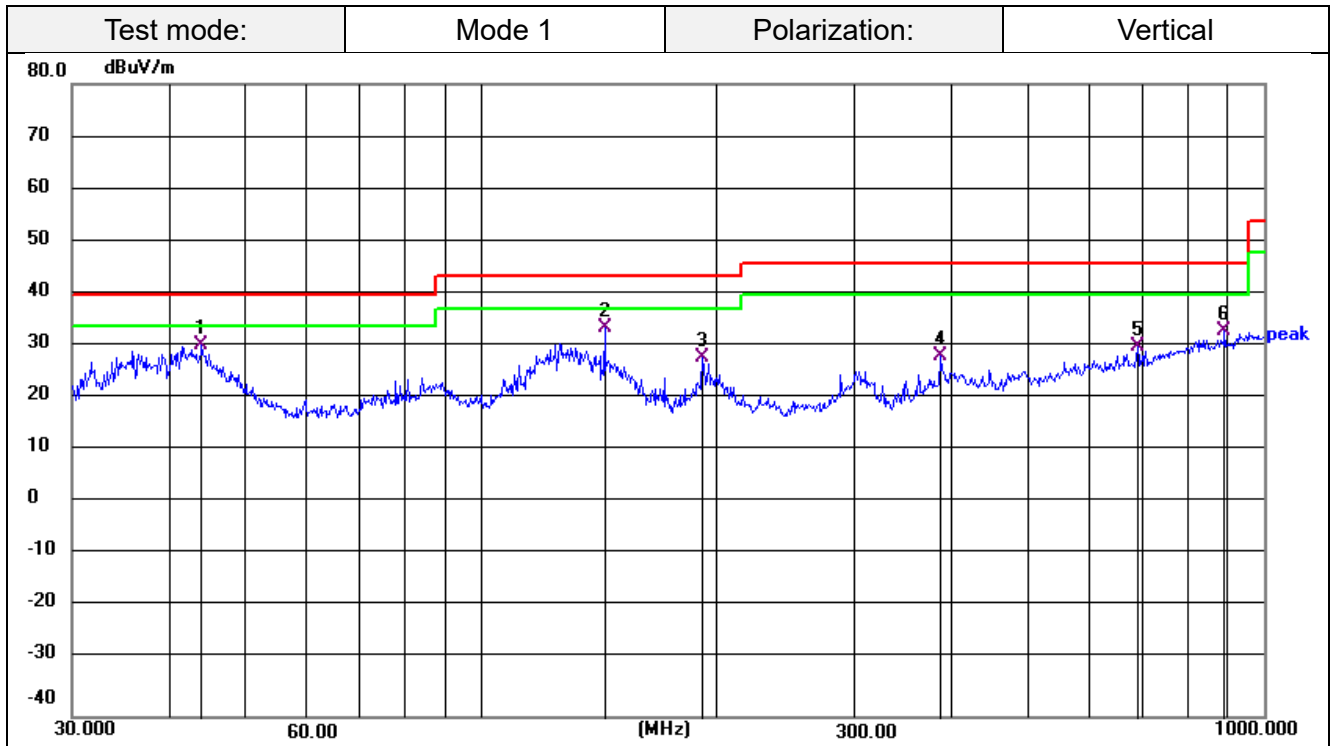

Remark:
 Emission Level = Reading + Factor;
 Factor = Antenna Factor + Cable Loss – Pre-amplifier;
 Margin= Emission Level - Limit.

No.	Frequency (MHz)	Reading (dBuV)	Factor (dB/m)	Level (dBuV/m)	Limit (dBuV/m)	Margin (dB)	Det.
1	43.9658	47.18	-16.66	30.52	40.00	-9.48	QP
2	143.8295	50.76	-17.00	33.76	43.50	-9.74	QP
3	191.7450	47.73	-19.55	28.18	43.50	-15.32	QP
4	386.6338	43.22	-14.85	28.37	46.00	-17.63	QP
5	689.5643	38.78	-8.39	30.39	46.00	-15.61	QP
6	890.7277	38.22	-4.93	33.29	46.00	-12.71	QP

3.3 20dB Bandwidth

Limit

The 20dB bandwidth shall be less than 80% of the permitted frequency band.

Test Procedure

1. Set RBW = 30Hz.
2. Set the video bandwidth (VBW) $\geq 3 \times$ RBW.
3. Detector = Peak.
4. Trace mode = max hold.
5. Sweep = auto couple.
6. Allow the trace to stabilize.
7. Measure the maximum width of the emission that is constrained by the frequencies associated with the two outermost amplitude points (upper and lower frequencies) that are attenuated by 20 dB relative to the maximum level measured in the fundamental emission.

Test setup

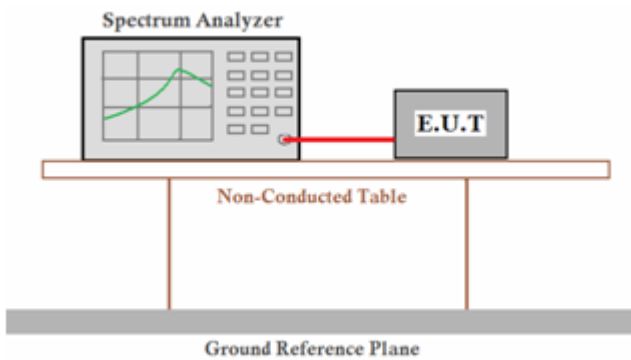

Test Results

Coil	Frequency (KHz)	20dB bandwidth (KHz)	99% bandwidth (KHz)	Result
Phone	126.7	0.085	-	Pass
	360.0	0.063	-	Pass
Earphone	167.5	0.078	-	Pass
Watch	327.0	0.177	-	Pass

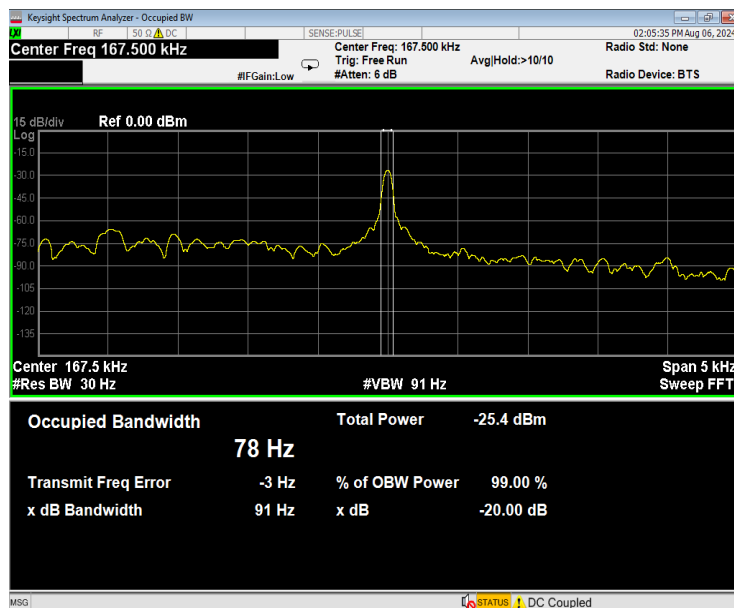
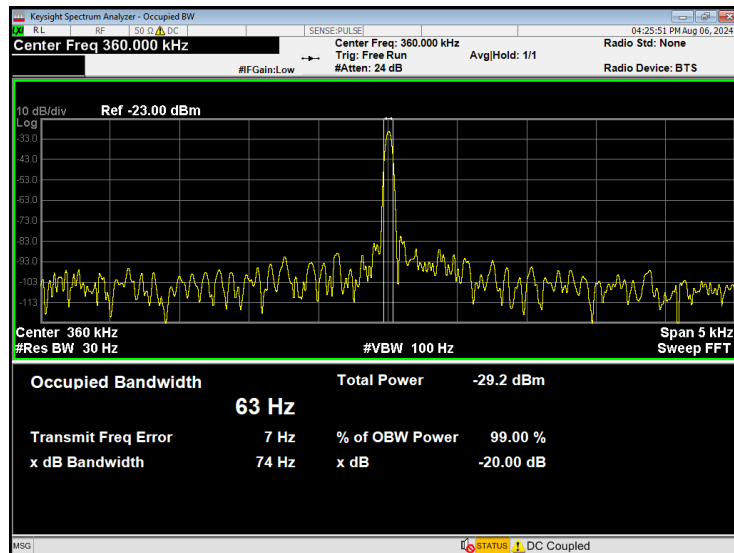
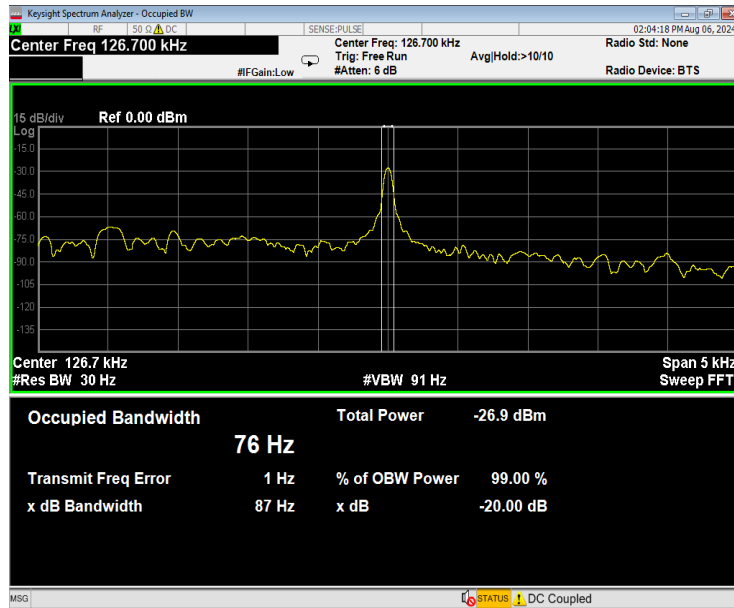

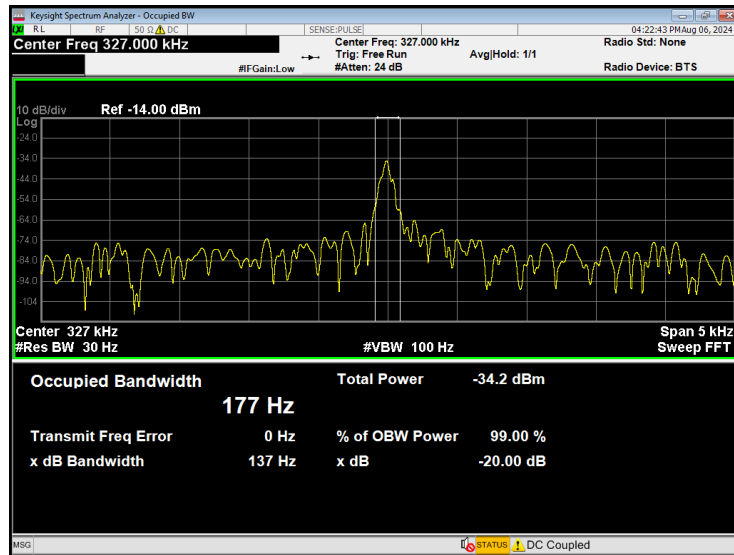

3.4 Antenna Requirement

Standard Applicable

For intentional device, according to FCC 47 CFR Section 15.203:

An intentional radiator shall be designed to ensure that no antenna other than that furnished by the responsible party shall be used with the device. The use of a permanently attached antenna or of an antenna that uses a unique coupling to the intentional radiator, the manufacturer may design the unit so that a broken antenna can be replaced by the user, but the use of a standard antenna jack or electrical connector is prohibited

Confirmation

The EUT's antenna is an Inductive Loop coil Antenna, the best case gain of the antenna is 0dBi.

4 Test Setup Photographs of EUT

Please refer to separated files for Test Setup Photos of the EUT.

5 External Photographs of EUT

Please refer to separated files for External Photos of the EUT.

6 Internal Photographs of EUT

Please refer to separated files for Internal Photos of the EUT.

***** End of Report *****