

# TEST REPORT

Report No.: BCTC2209305453-3E

---

Applicant: Pacific Time Trading(Shenzhen)Limited

---

Product Name: Carplay

---

Model/Type  
reference: R9

---

Tested Date: 2022-09-07 to 2022-10-31

---

Issued Date: 2022-10-31

---

**Shenzhen BCTC Testing Co., Ltd.**



**FCC ID: 2AV8I-R9**

Product Name: Carplay  
Trademark: Coral Vision  
Model/Type reference: R9  
D9, M9, S9  
Prepared For: Pacific Time Trading(Shenzhen)Limited  
Address: Unit 607, block A, Rong Chaoying Long building, 5 longfuRoad, Longcheng street,  
Longgang District, Shenzhen, China  
Manufacturer: TFVC SHANGHAI CO.,LTD  
Address: Rm 103, 1 Lane 666 Xinhua Road, Changning District, Shanghai, China  
Prepared By: Shenzhen BCTC Testing Co., Ltd.  
Address: 1-2/F., Building B, Pengzhou Industrial Park, No.158, Fuyuan 1st Road, Zhancheng,  
Fuhai Subdistrict, Bao'an District, Shenzhen, Guangdong, China  
Sample Received Date: 2022-09-07  
Sample tested Date: 2022-09-07 to 2022-10-31  
Issue Date: 2022-10-31  
Report No.: BCTC2209305453-3E  
Test Standards: FCC Part15.239  
ANSI C63.10:2013  
Test Results: PASS

Tested by:



Lei Chen/Project Handler

Approved by:



Zero Zhou/Reviewer

The test report is effective only with both signature and specialized stamp. This result(s) shown in this report refer only to the sample(s) tested. Without written approval of Shenzhen BCTC Testing Co., Ltd, this report can't be reproduced except in full. The tested sample(s) and the sample information are provided by the client.



## Table Of Content

Test Report Declaration	Page
1. Version .....	4
2. Test Summary .....	5
3. Measurement Uncertainty .....	6
4. Product Information And Test Setup .....	7
4.1 Product Information.....	7
4.2 Test Setup Configuration .....	8
4.4 Channel List .....	9
4.5 Test Mode .....	9
4.6 Table Of Parameters Of Text Software Setting .....	9
5. Test Facility And Test Instrument Used.....	10
5.1 Test Facility.....	10
5.2 Test Instrument Used.....	10
6. Conducted Emissions.....	12
6.1 Block Diagram Of Test Setup.....	12
6.2 Limit .....	12
6.3 Test Procedure .....	12
6.4 EUT Operating Conditions .....	12
6.5 Test Result.....	13
7. Radiated Emissions.....	15
7.1 Block Diagram Of Test Setup.....	15
7.2 Limit .....	16
7.3 Test Procedure .....	18
7.4 EUT Operating Conditions .....	19
7.5 Test Result.....	19
8. Bandwidth Test.....	28
8.1 Applied Procedures / Limit .....	28
8.2 Test Procedure .....	28
8.3 Deviation From Standard .....	28
8.4 Test Setup.....	28
8.5 Eut Operation Conditions .....	28
8.6 Test Result.....	29
9. Band Edge Measurement.....	31
9.1 Block Diagram Of Test Setup.....	31
9.2 Applicable Standard .....	31
9.3 Test Procedure .....	31
9.4 Eut Operation Conditions .....	31
9.5 Test Results .....	32
10. Antenna Requirement .....	33
10.1 Standard Requirement.....	33
10.2 EUT Antenna .....	33
11. EUT Photographs.....	34
12. EUT Test Setup Photographs.....	35

(Note: N/A Means Not Applicable)

 BCTC  
 BCTC  
 PPR  
 检测

**1. Version**

Report No.	Issue Date	Description	Approved
BCTC2209305453-3E	2022-10-31	Original	Valid

TEC  
TC  
OVER  
檢

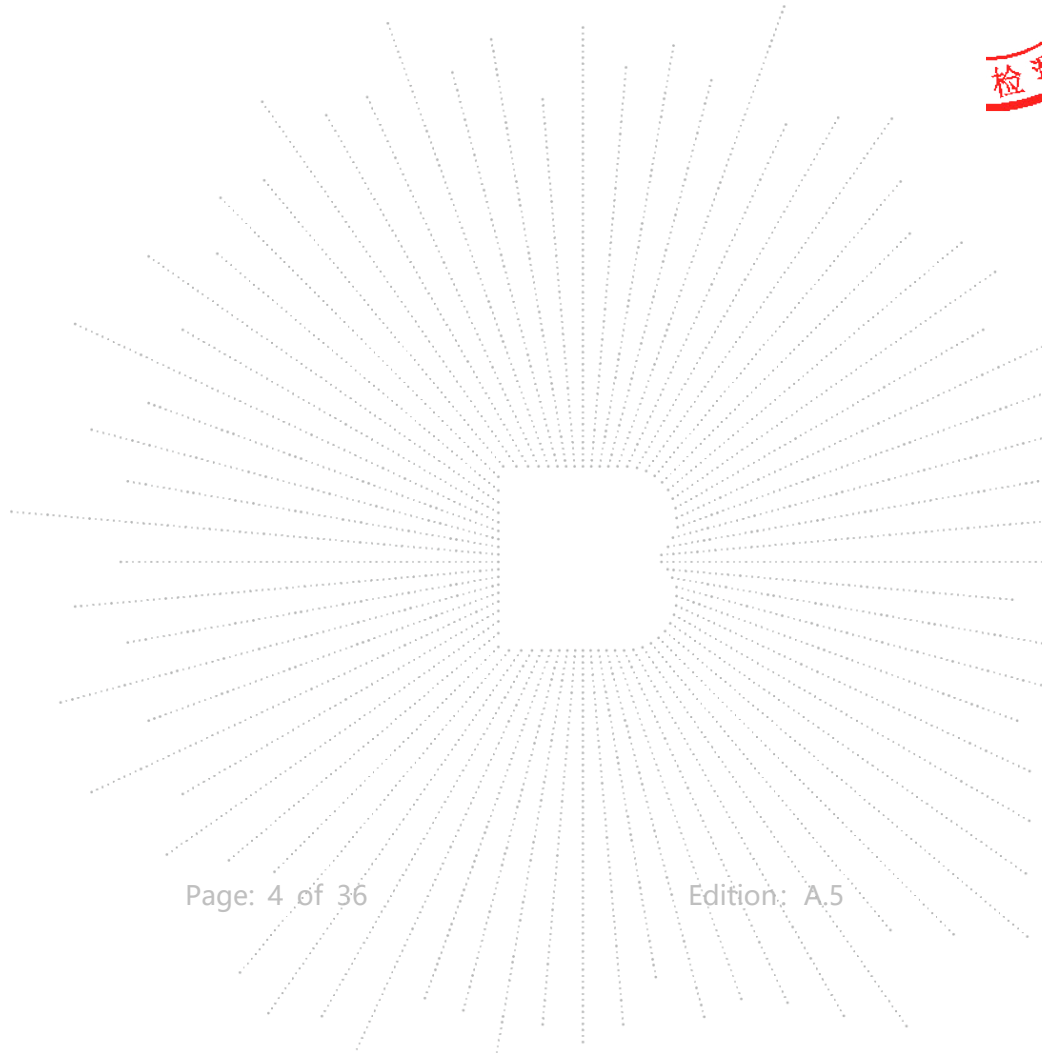

## 2. Test Summary

The Product has been tested according to the following specifications:

<b>FCC Part15 (15.239) , Subpart C</b>			
Standard Section	Test Item	Judgment	Remark
15.207	Conducted Emission	PASS	
15.209&15.239	Fundamental &Radiated Spurious Emission Measurement	PASS	
15.239a	Occupy Bandwidth	PASS	
15.203	Antenna Requirement	PASS	
15.239a	Band Edge Measurement	PASS	

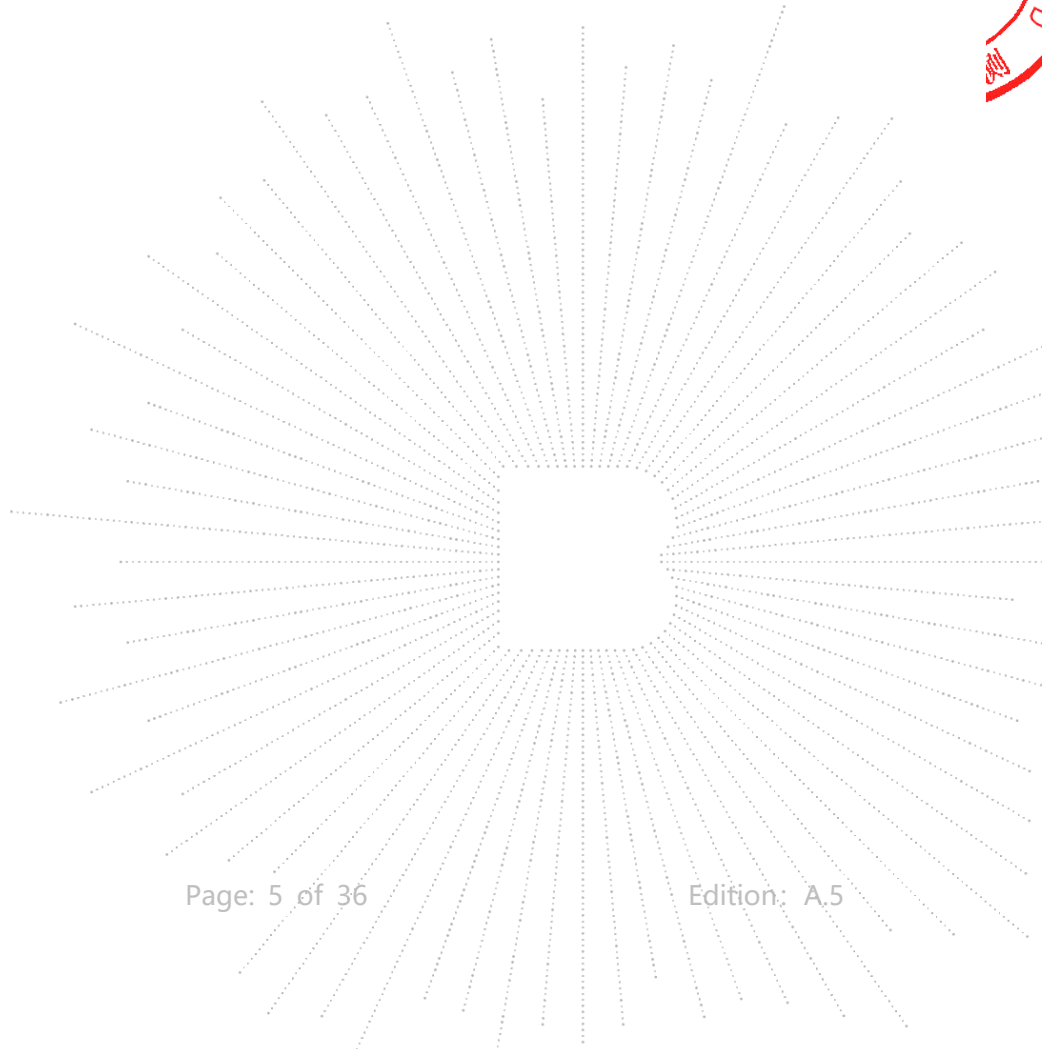

### 3. Measurement Uncertainty

Where relevant, the following measurement uncertainty levels have been estimated for tests performed on the Product as specified in CISPR 16-4-2. This uncertainty represents an expanded uncertainty expressed at approximately the 95% confidence level using a coverage factor of  $k=2$ .

No.	Item	Uncertainty
1	3m chamber Radiated spurious emission(30MHz-1GHz)	U=4.3dB
2	3m chamber Radiated spurious emission(1GHz-18GHz)	U=4.5dB
3	3m chamber Radiated spurious emission(18GHz-40GHz)	U=3.34dB
4	Conducted Adjacent channel power	U=1.38dB
5	Conducted output power uncertainty Above 1G	U=1.576dB
6	Conducted output power uncertainty below 1G	U=1.28dB
7	humidity uncertainty	U=5.3%
8	Temperature uncertainty	U=0.59°C

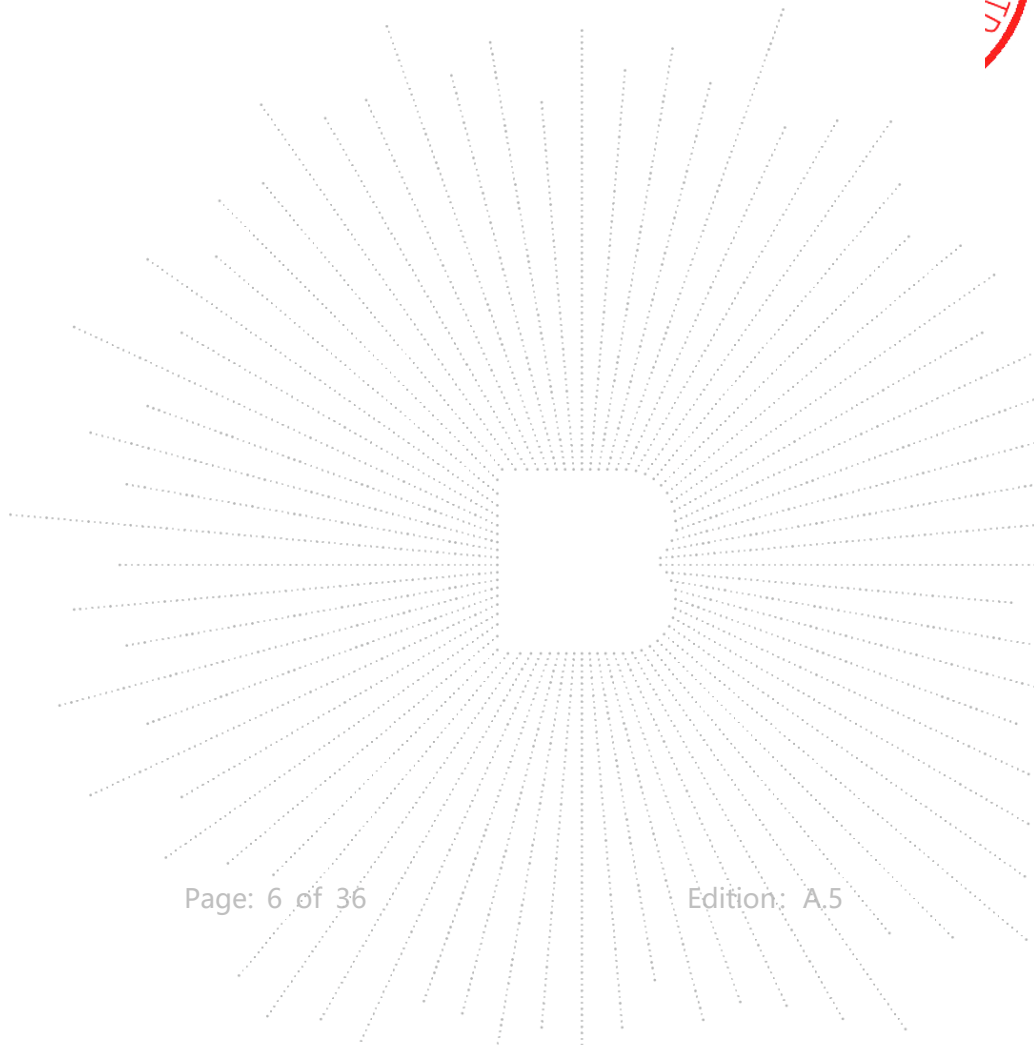
## 4. Product Information And Test Setup

### 4.1 Product Information

Model/Type reference:	R9 D9, M9, S9
Model differences:	All the model are the same circuit and RF module, except model names and color.
Hardware Version:	Coral Vision-R9-1-v1.1
Software Version:	CORAL_R9-335-V1.1.25-g7e0506c-20220820-110038
Operation Frequency:	88.1-107.9MHz
Type of Modulation:	FM
Number Of Channel	199CH
Antenna installation:	FPC antenna
Antenna Gain:	0dBi
Ratings:	DC 5V

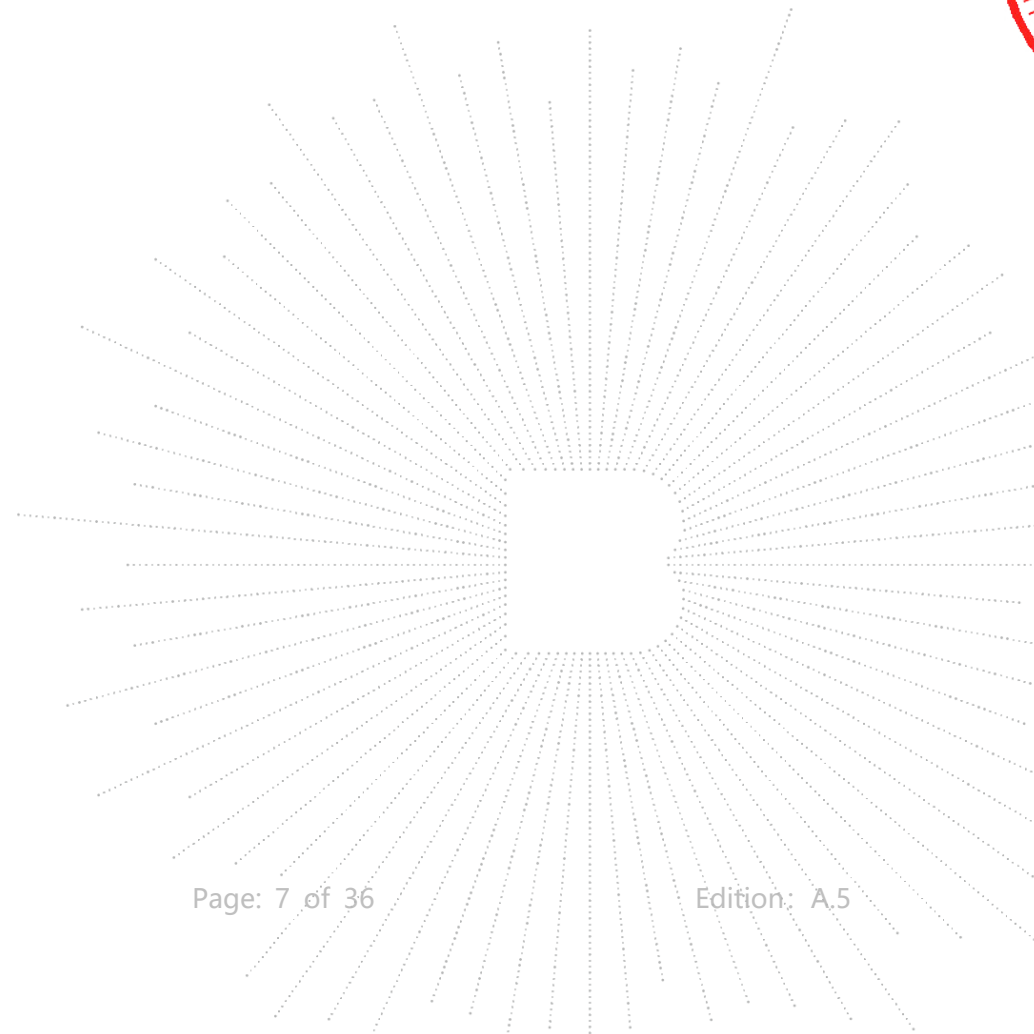

## 4.2 Test Setup Configuration

See test photographs attached in *EUT TEST SETUP PHOTOGRAPHS* for the actual connections between Product and support equipment.

Conducted Emission:

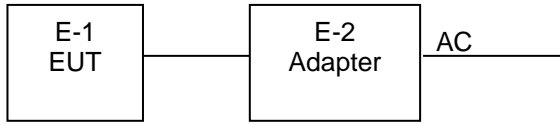

Radiated Spurious Emission

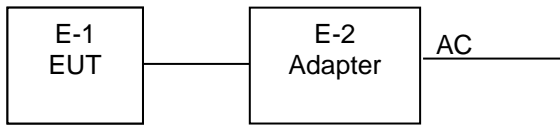

## 4.3 Support Equipment

No.	Device Type	Brand	Model	Series No.	Note
E-1	Carplay	Coral Vision	R9	D9, M9, S9	EUT
E-2	Adapter	N/A	BCTC001	N/A	Auxiliary

**Notes:**

1. All the equipment/cables were placed in the worst-case configuration to maximize the emission during the test.
2. Grounding was established in accordance with the manufacturer's requirements and conditions for the intended use.





#### 4.4 Channel List

Channel List					
Channel	Frequency (MHz)	Channel	Frequency (MHz)	Channel	Frequency (MHz)
1	88.1	2	88.2	3	88.3
~					
100	98	101	98.1	102	98.2
~					
197	107.7	198	107.8	199	107.9

#### 4.5 Test Mode

To investigate the maximum EMI emission characteristics generated from EUT, the test system was pre-scanning tested based on the consideration of following EUT operation mode or test configuration mode which possibly have effect on EMI emission level. Each of these EUT operation mode(s) or test configuration mode(s) mentioned above was evaluated respectively.

For All Mode	Description	Modulation Type
Mode 1	CH1	FM
Mode 2	CH100	FM
Mode 3	CH199	FM
Mode 4	Transmission (Conducted emission & Radiated emission)	

Note:

(1) The measurements are performed at the highest, middle, lowest available channels.

#### 4.6 Table Of Parameters Of Test Software Setting

During testing channel & power controlling software provided by the customer was used to control the operating channel as well as the output power level. The RF output power selection is for the setting of RF output power expected by the customer and is going to be fixed on the firmware of the final end product power parameters

Test software Version	N/A		
Frequency	88.1 MHz	98 MHz	107.9 MHz
Parameters	DEF	DEF	DEF

BCTC  
 3C  
 PPR  
 检测

## 5. Test Facility And Test Instrument Used

### 5.1 Test Facility

All measurement facilities used to collect the measurement data are located at Shenzhen BCTC Testing Co., Ltd. Address: 1-2/F., Building B, Pengzhou Industrial Park, No.158, Fuyuan 1st Road, Zhancheng, Fuhai Subdistrict, Bao'an District, Shenzhen, Guangdong, China. The site and apparatus are constructed in conformance with the requirements of ANSI C63.4 and CISPR 16-1-1 other equivalent standards.

### 5.2 Test Instrument Used

Conducted Emissions Test					
Equipment	Manufacturer	Model#	Serial#	Last Cal.	Next Cal.
Receiver	R&S	ESR3	102075	May 24, 2022	May 23, 2023
LISN	R&S	ENV216	101375	May 24, 2022	May 23, 2023
Software	Frad	EZ-EMC	EMC-CON 3A1	\	\
Attenuator	\	10dB DC-6GHz	1650	May 24, 2022	May 23, 2023

RF Conducted Test					
Equipment	Manufacturer	Model#	Serial#	Last Cal.	Next Cal.
Power Metter	Keysight	E4419	\	May 24, 2022	May 23, 2023
Power Sensor (AV)	Keysight	E9300A	\	May 24, 2022	May 23, 2023
Signal Analyzer 20kHz-26.5G Hz	Keysight	N9020A	MY49100060	May 24, 2022	May 23, 2023
Spectrum Analyzer 9kHz-40GHz	R&S	FSP 40	\	May 24, 2022	May 23, 2023

 TE  
 TC  
 OVE  
 检

Radiated Emissions Test (966 Chamber)					
Equipment	Manufacturer	Model#	Serial#	Last Cal.	Next Cal.
966 chamber	ChengYu	966 Room	966	Jun. 06. 2020	Jun. 05, 2023
Receiver	R&S	ESR3	102075	May 24, 2022	May 23, 2023
Receiver	R&S	ESRP	101154	May 24, 2022	May 23, 2023
Amplifier	SKET	LAPA_01G18 G-45dB	\	May 24, 2022	May 23, 2023
Amplifier	Schwarzbeck	BBV9744	9744-0037	May 24, 2022	May 23, 2023
TRILOG Broadband Antenna	Schwarzbeck	VULB9163	942	May 26, 2022	May 25, 2023
Horn Antenna	Schwarzbeck	BBHA9120D	1541	Jun. 06, 2022	Jun. 05, 2023
Horn Antenn (18GHz-40GHz)	Schwarzbeck	BBHA9170	00822	Jun. 06, 2022	Jun. 05, 2023
Amplifier (18GHz-40GHz)	MITEQ	TTA1840-35- HG	2034381	May 26, 2022	May 25, 2023
Loop Antenna (9kHz-30MHz)	Schwarzbeck	FMZB1519B	00014	May 26, 2022	May 25, 2023
RF cables1 (9kHz-30MHz)	Huber+Suhnar	9kHz-30MHz	B1702988-000 8	May 26, 2022	May 25, 2023
RF cables2 (30MHz-1GHz)	Huber+Suhnar	30MHz-1GHz	1486150	May 26, 2022	May 25, 2023
RF cables3 (1GHz-40GHz)	Huber+Suhnar	1GHz-40GHz	1607106	May 26, 2022	May 25, 2023
Power Metter	Keysight	E4419	\	May 26, 2022	May 25, 2023
Power Sensor (AV)	Keysight	E9300A	\	May 26, 2022	May 25, 2023
Signal Analyzer 20kHz-26.5GHz	Keysight	N9020A	MY49100060	May 26, 2022	May 25, 2023
Spectrum Analyzer 9kHz-40GHz	R&S	FSP 40	\	May 26, 2022	May 25, 2023
Software	Frad	EZ-EMC	FA-03A2 RE	\	\



## 6. Conducted Emissions

### 6.1 Block Diagram Of Test Setup



### 6.2 Limit

Frequency (MHz)	Limit (dBuV)	
	Quas-peak	Average
0.15 -0.5	66 - 56 *	56 - 46 *
0.50 -5.0	56.00	46.00
5.0 -30.0	60.00	50.00

Notes:  
 1. \*Decreasing linearly with logarithm of frequency.  
 2. The lower limit shall apply at the transition frequencies.

### 6.3 Test Procedure

Receiver Parameters	Setting
Attenuation	10 dB
Start Frequency	0.15 MHz
Stop Frequency	30 MHz
IF Bandwidth	9 kHz

- The Product was placed on a nonconductive table 0.8 m above the horizontal ground reference plane, and 0.4 m from the vertical ground reference plane, and connected to the main through Line Impedance Stability Network (L.I.S.N).
- The RBW of the receiver was set at 9 kHz in 150 kHz ~ 30MHz with Peak and AVG detector in Max Hold mode. Run the receiver's pre-scan to record the maximum disturbance generated from Product in all power lines in the full band.
- For each frequency whose maximum record was higher or close to limit, measure its QP and AVG values and record.

### 6.4 EUT Operating Conditions

The EUT was configured for testing in a typical fashion (as a customer would normally use it). The EUT has been programmed to continuously transmit during test. This operating condition was tested and used to collect the included data.

## 6.5 Test Result

Temperature:	26 °C	Relative Humidity:	54%
Pressure:	101kPa	Phase :	Line
Test Voltage :	AC120V/60Hz	Test Mode:	Mode 4

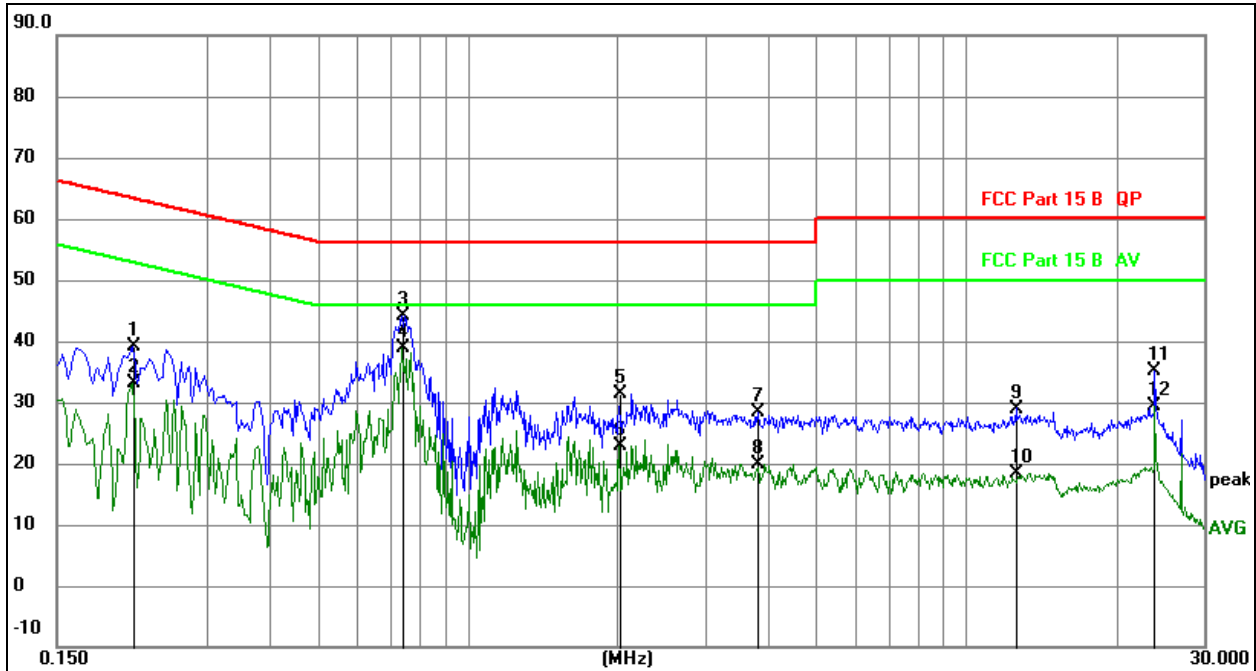

## Remark:

1. All readings are Quasi-Peak and Average values.
2. Factor = Insertion Loss + Cable Loss.
3. Measurement=Reading Level+ Correct Factor
4. Over= Measurement-Limit

No.	Mk.	Freq. MHz	Reading Level	Correct Factor dB	Measure- ment dBuV	Limit dBuV	Over dB	Detector
1		0.2128	19.38	19.80	39.18	63.10	-23.92	QP
2		0.2128	13.39	19.80	33.19	53.10	-19.91	AVG
3		0.7391	24.47	19.74	44.21	56.00	-11.79	QP
4	*	0.7391	19.16	19.74	38.90	46.00	-7.10	AVG
5		2.0119	11.42	19.88	31.30	56.00	-24.70	QP
6		2.0119	3.12	19.88	23.00	46.00	-23.00	AVG
7		3.8196	8.18	20.08	28.26	56.00	-27.74	QP
8		3.8196	-0.16	20.08	19.92	46.00	-26.08	AVG
9		12.5821	8.72	20.28	29.00	60.00	-31.00	QP
10		12.5821	-1.89	20.28	18.39	50.00	-31.61	AVG
11		23.8878	14.50	20.52	35.02	60.00	-24.98	QP
12		23.8878	8.80	20.52	29.32	50.00	-20.68	AVG

SHENZHEN

Temperature:	26 °C	Relative Humidity:	54%
Pressure:	101kPa	Phase :	Neutral
Test Voltage :	AC120V/60Hz	Test Mode:	Mode 4

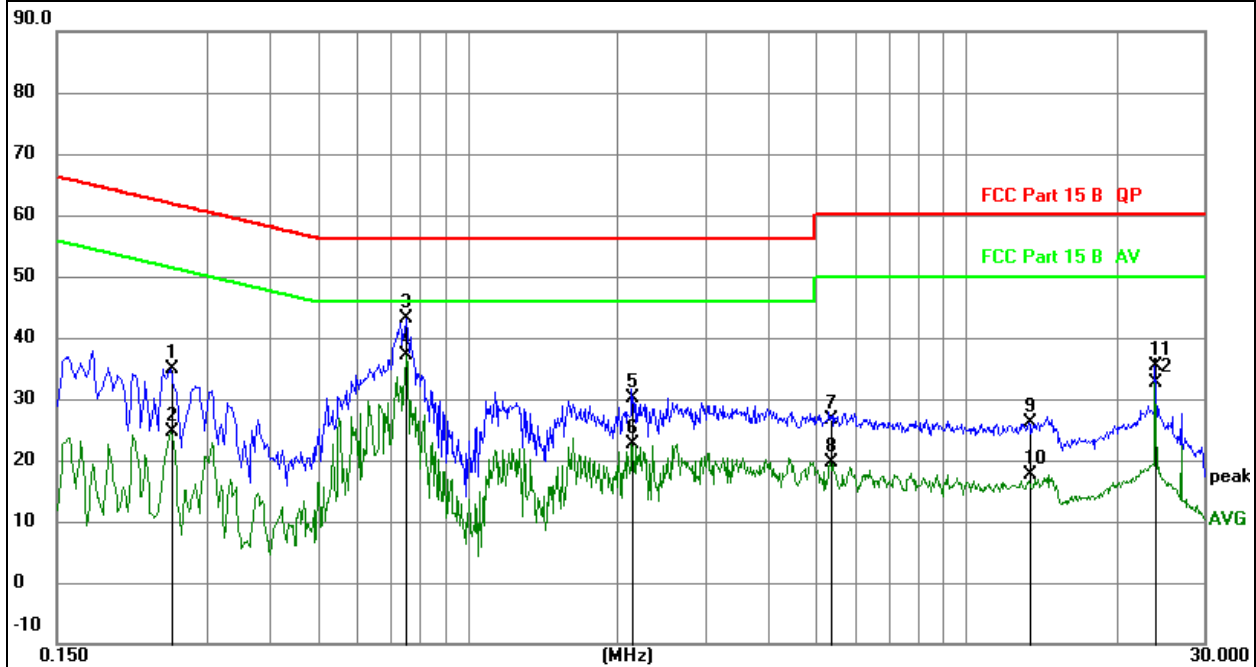
**Remark:**

1. All readings are Quasi-Peak and Average values.
2. Factor = Insertion Loss + Cable Loss.
3. Measurement=Reading Level+ Correct Factor
4. Over= Measurement-Limit

No.	Mk.	Freq. MHz	Reading Level	Correct Factor dB	Measure- ment dBuV	Limit dBuV	Over dB	Detector
1		0.2535	15.09	19.79	34.88	61.64	-26.76	QP
2		0.2535	4.81	19.79	24.60	51.64	-27.04	AVG
3		0.7529	23.38	19.74	43.12	56.00	-12.88	QP
4	*	0.7529	17.39	19.74	37.13	46.00	-8.87	AVG
5		2.1389	10.33	19.90	30.23	56.00	-25.77	QP
6		2.1389	2.76	19.90	22.66	46.00	-23.34	AVG
7		5.3385	6.59	20.14	26.73	60.00	-33.27	QP
8		5.3385	-0.52	20.14	19.62	50.00	-30.38	AVG
9		13.3620	5.95	20.28	26.23	60.00	-33.77	QP
10		13.3620	-2.68	20.28	17.60	50.00	-32.40	AVG
11		24.0045	14.87	20.52	35.39	60.00	-24.61	QP
12		24.0045	12.07	20.52	32.59	50.00	-17.41	AVG

## 7. Radiated Emissions

### 7.1 Block Diagram Of Test Setup

(A) Radiated Emission Test-Up Frequency Below 30MHz

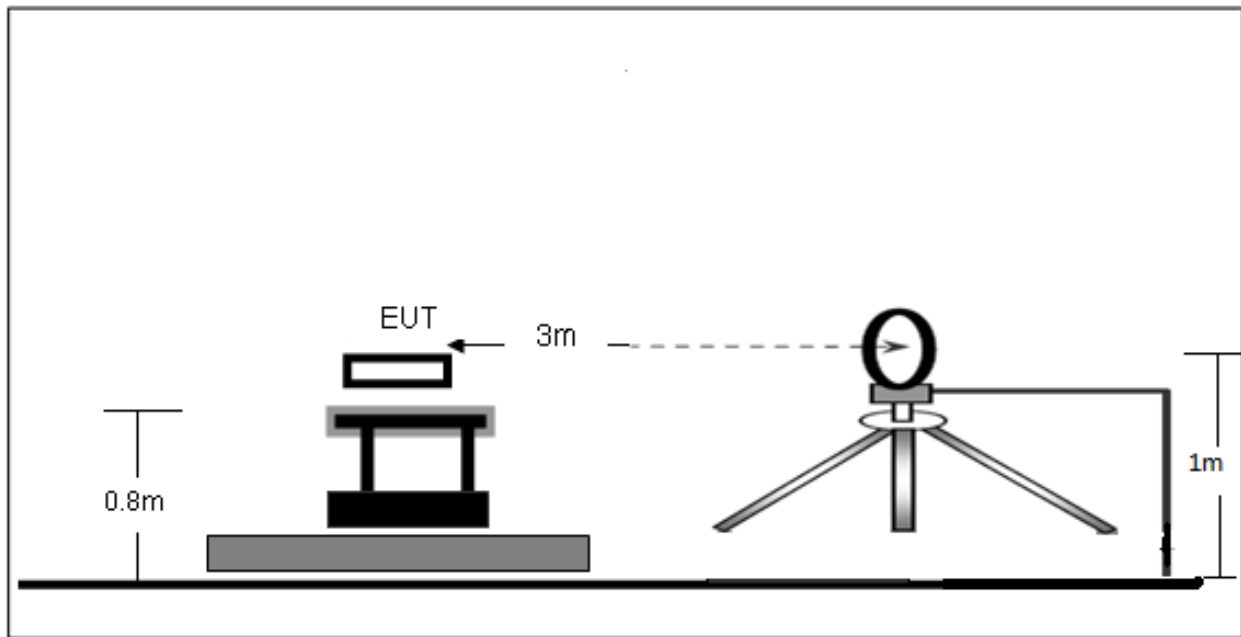

(B) Radiated Emission Test-Up Frequency 30MHz~1GHz

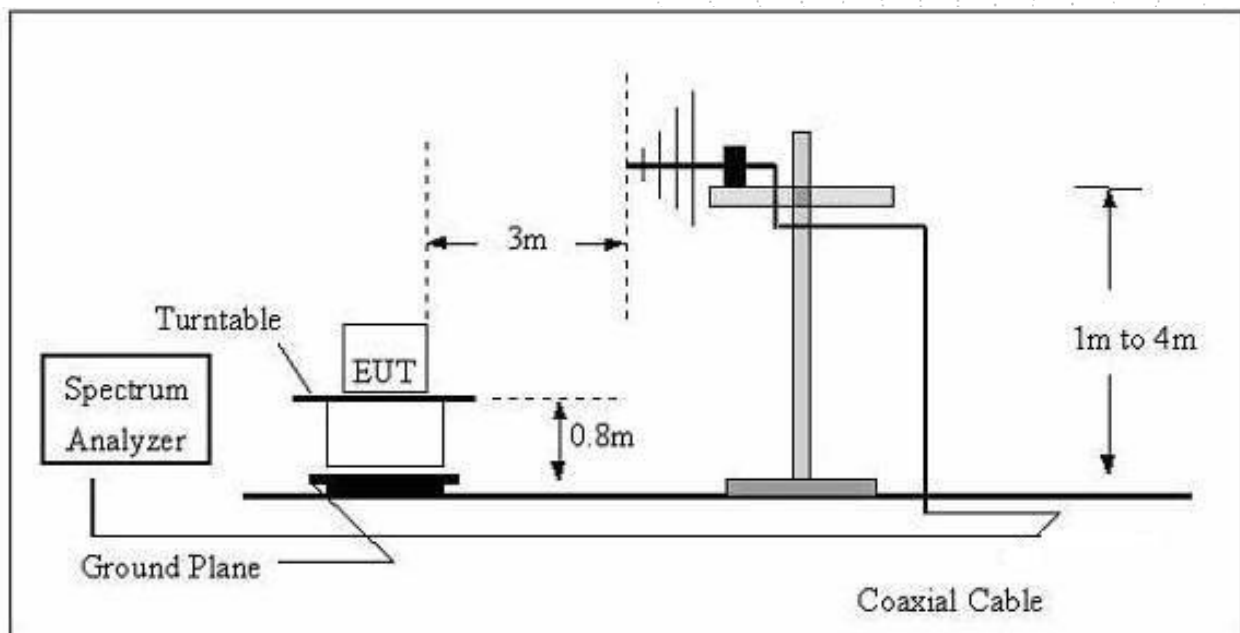

TC  
3C  
PPR  
測







20dBc in any 100 kHz bandwidth outside the operating frequency band. In case the emission fall within the restricted band specified on 15.205(a), then the 15.209(a) limit in the table below has to be followed.

Frequency (MHz)	Field Strength uV/m	Distance (m)	Field Strength Limit at 3m Distance	
			uV/m	dBuV/m
0.009 ~ 0.490	2400/F(kHz)	300	10000 * 2400/F(kHz)	20log <sup>(2400/F(kHz))</sup> + 80
0.490 ~ 1.705	24000/F(kHz)	30	100 * 24000/F(kHz)	20log <sup>(24000/F(kHz))</sup> + 40
1.705 ~ 30	30	30	100 * 30	20log <sup>(30)</sup> + 40
30 ~ 88	100	3	100	20log <sup>(100)</sup>
88 ~ 216	150	3	150	20log <sup>(150)</sup>
216 ~ 960	200	3	200	20log <sup>(200)</sup>
Above 960	500	3	500	20log <sup>(500)</sup>

#### Limits Of Radiated Emission Measurement (Above 1000MHz)

Frequency (MHz)	Limit (dBuV/m) (at 3M)	
	Peak	Average
Above 1000	74	54

#### Notes:

- (1) The limit for radiated test was performed according to FCC PART 15C.
- (2) The tighter limit applies at the band edges.
- (3) Emission level (dBuV/m)=20log Emission level (uV/m).

#### Frequency Range Of Radiated Measurement (For unintentional radiators)

Highest frequency generated or Upper frequency of measurement used in the device or on which the device operates or tunes (MHz)	Range (MHz)
Below 1.705	30
1.705 – 108	1000
108 – 500	2000
500 – 1000	5000
Above 1000	5 <sup>th</sup> harmonic of the highest frequency or 40 GHz, whichever is lower

### 7.3 Test Procedure

Receiver Parameter	Setting
Attenuation	Auto
9kHz~150kHz	RBW 200Hz for QP
150kHz~30MHz	RBW 9kHz for QP
30MHz~1000MHz	RBW 120kHz for QP

Spectrum Parameter	Setting
1-25GHz	RBW 1 MHz /VBW 1 MHz for Peak, RBW 1 MHz / VBW 10Hz for Average

Below 1GHz test procedure as below:

- The EUT was placed on the top of a rotating table 0.8 meters above the ground at a 3 meter semi-anechoic chamber. The table was rotated 360 degrees to determine the position of the highest radiation.
- The EUT was set 3 meters away from the interference-receiving antenna, which was mounted on the top of a variable-height antenna tower.
- The antenna height is varied from one meter to four meters above the ground to determine the maximum value of the field strength. Both horizontal and vertical polarizations of the antenna are set to make the measurement.
- For each suspected emission, the EUT was arranged to its worst case and then the antenna was tuned to heights from 1 meter to 4 meters (for the test frequency of below 30MHz, the antenna was tuned to heights 1 meter) and the rotatable table was turned from 0 degrees to 360 degrees to find the maximum reading.
- The test-receiver system was set to Peak Detect Function and Specified Bandwidth with Maximum Hold Mode.
- If the emission level of the EUT in peak mode was 10dB lower than the limit specified, then testing could be stopped and the peak values of the EUT would be reported. Otherwise the emissions that did not have 10dB margin would be re-tested one by one using peak, quasi-peak or average method as specified and then reported in a data sheet.

Above 1GHz test procedure as below:

- Different between above is the test site, change from Semi- Anechoic Chamber to fully Anechoic Chamber and change form table 0.8 metre to 1.5 metre( Above 18GHz the distance is 1 meter and table is 1.5 metre).
- Test the EUT in the lowest channel ,the middle channel ,the Highest channel.

Note:

Both horizontal and vertical antenna polarities were tested and performed pretest to three orthogonal axis. The worst case emissions were reported.

Above 1GHz test procedure as below:

- The EUT was placed on the top of a rotating table 1.5 meters above the ground at a 3 meter chamber. The table was rotated 360 degrees to determine the position of the highest radiation.
- The EUT was set 3 meters away from the interference-receiving antenna, which was mounted on the top of a variable-height antenna tower.
- The antenna height is varied from one meter to four meters above the ground to determine the maximum value of the field strength. Both horizontal and vertical polarizations of the antenna are set to make the measurement.
- For each suspected emission, the EUT was arranged to its worst case and then the antenna was tuned to heights from 1 meter to 4 meters and the rota table was turned from 0 degrees to 360 degrees to find the maximum reading.
- The test-receiver system was set to Peak Detect Function and Specified Bandwidth with Maximum Hold Mode.
- If the emission level of the EUT in peak mode was 10dB lower than the limit specified, then testing could be stopped and the peak values of the EUT would be reported. Otherwise the emissions that did not have

10dB margin would be re-tested one by one using peak, quasi-peak or average method as specified and then reported in a data sheet.

g. Test the EUT in the lowest channel, the Highest channel.

Note:

Both horizontal and vertical antenna polarities were tested and performed pretest to three orthogonal axis. The worst case emissions were reported.

## 7.4 EUT Operating Conditions

The EUT was configured for testing in a typical fashion (as a customer would normally use it). The EUT has been programmed to continuously transmit during test. This operating condition was tested and used to collect the included data.

## 7.5 Test Result

Below 30MHz

Temperature:	26°C	Relative Humidity:	24%
Pressure:	101 kPa	Test Voltage :	AC120V/60Hz

Freq. (MHz)	Reading (dBuV/m)	Limit (dBuV/m)	Margin (dB)	State P/F
--	--	--	--	PASS
--	--	--	--	PASS

Note:

The amplitude of spurious emissions which are attenuated by more than 20dB below the permissible value has no need to be reported.

Distance extrapolation factor =  $40 \log(\text{specific distance/test distance})$ (dB);

Limit line = specific limits(dBuv) + distance extrapolation factor.



Between 30MHz – 1GHz

Temperature:	26°C	Relative Humidity:	54%
Pressure:	101 kPa	Test Voltage :	AC120V/60Hz
Test Mode:	Mode 1 (88.1MHz)	Polarization :	Horizontal

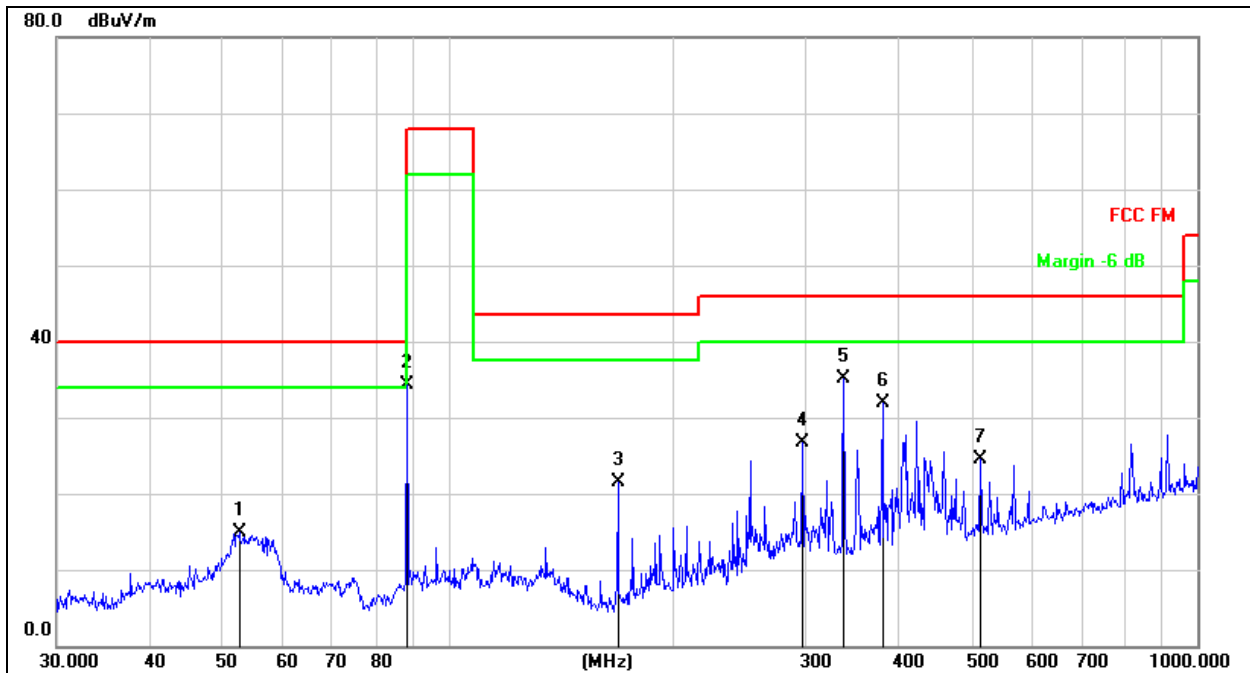
**Remark:**

1. Factor = Antenna Factor + Cable Loss – Pre-amplifier.
2. Measurement=Reading Level+ Correct Factor
3. Over= Measurement-Limit

No.	Mk.	Freq.	Reading Level	Correct Factor	Measurement	Limit	Over	Detector
		MHz	dBuV	dB	dBuV/m	dB/m	dB	
1		52.5753	30.87	-15.98	14.89	40.00	-25.11	QP
2		88.0329	54.01	-19.69	34.32	68.00	-33.68	peak
3		168.4138	41.27	-19.69	21.58	43.50	-21.92	QP
4		297.2241	41.39	-14.65	26.74	46.00	-19.26	QP
5	*	337.2155	48.40	-13.25	35.15	46.00	-10.85	QP
6		379.9141	44.30	-12.44	31.86	46.00	-14.14	QP
7		513.6331	34.48	-10.05	24.43	46.00	-21.57	QP

Temperature:	26°C	Relative Humidity:	54%
Pressure:	101 kpa	Test Voltage :	AC 120V/60Hz
Test Mode:	Mode 1 (88.1MHz)	Polarization :	Vertical

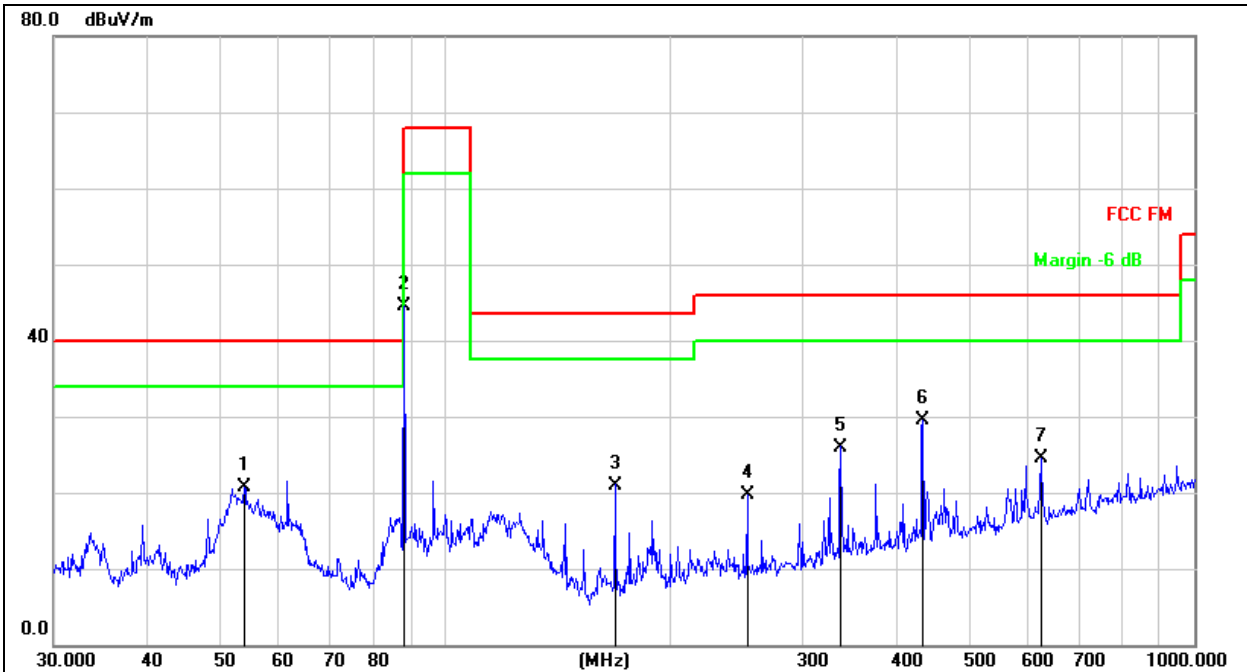
**Remark:**

1. Factor = Antenna Factor + Cable Loss – Pre-amplifier.
2. Measurement=Reading Level+ Correct Factor
3. Over= Measurement-Limit

No.	Mk.	Freq.	Reading Level	Correct Factor	Measurement	Limit	Over	Detector
		MHz	dBuV	dB	dBuV/m	dB/m	dB	
1		53.8818	36.94	-16.17	20.77	40.00	-19.23	QP
2		88.0329	64.20	-19.69	44.51	68.00	-23.49	peak
3		168.4138	40.69	-19.69	21.00	43.50	-22.50	QP
4		252.9482	35.53	-15.76	19.77	46.00	-26.23	QP
5		337.2155	39.25	-13.25	26.00	46.00	-20.00	QP
6	*	434.0651	41.21	-11.72	29.49	46.00	-16.51	QP
7		625.0780	32.51	-8.05	24.46	46.00	-21.54	QP

Temperature:	26°C	Relative Humidity:	54%
Pressure:	101 kPa	Test Voltage :	AC120V/60Hz
Test Mode:	Mode 2 (98MHz)	Polarization :	Horizontal

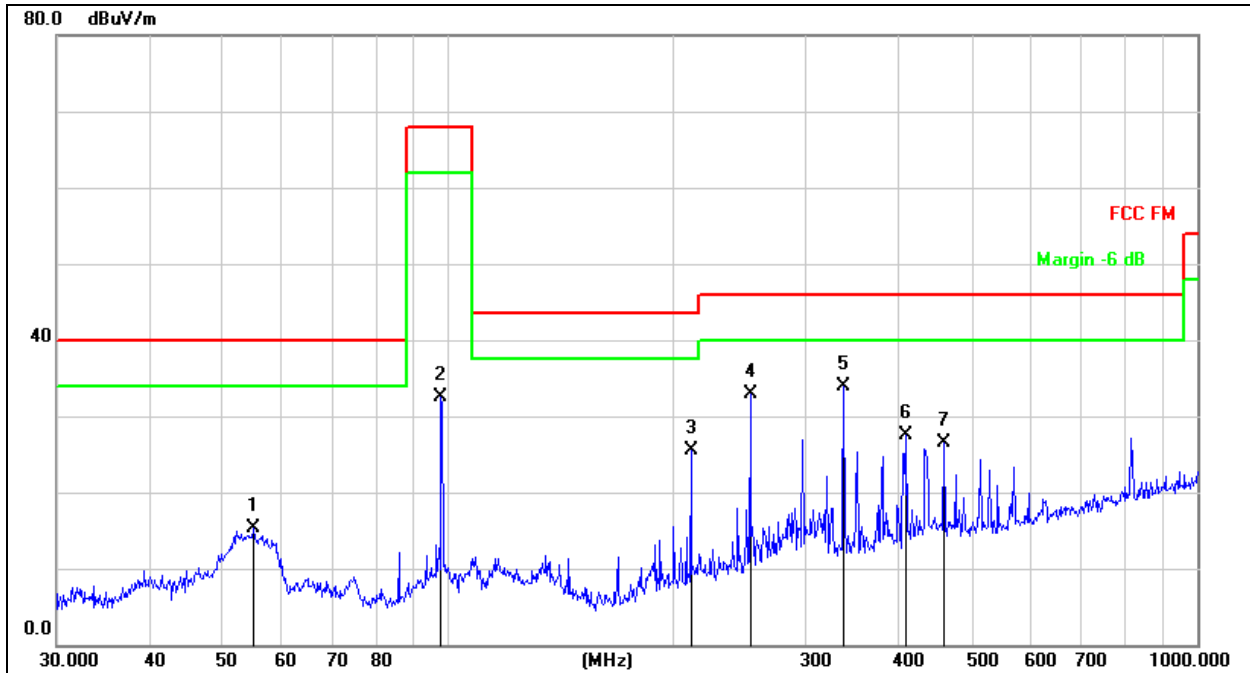
**Remark:**

1. Factor = Antenna Factor + Cable Loss – Pre-amplifier.
2. Measurement=Reading Level+ Correct Factor
3. Over= Measurement-Limit

No.	Mk.	Freq.	Reading Level	Correct Factor	Measurement	Limit	Over	Detector
		MHz	dBuV	dB	dBuV/m	dB/m	dB	
1		55.0274	31.62	-16.34	15.28	40.00	-24.72	QP
2		97.7983	50.55	-18.08	32.47	68.00	-35.53	peak
3		210.7860	42.51	-17.04	25.47	43.50	-18.03	QP
4		252.9482	48.65	-15.76	32.89	46.00	-13.11	QP
5	*	337.2155	47.21	-13.25	33.96	46.00	-12.04	QP
6		408.9460	39.51	-12.08	27.43	46.00	-18.57	QP
7		459.1144	37.75	-11.26	26.49	46.00	-19.51	QP

Temperature:	26°C	Relative Humidity:	54%
Pressure:	101 kpa	Test Voltage :	AC 120V/60Hz
Test Mode:	Mode 2 (98MHz)	Polarization :	Vertical

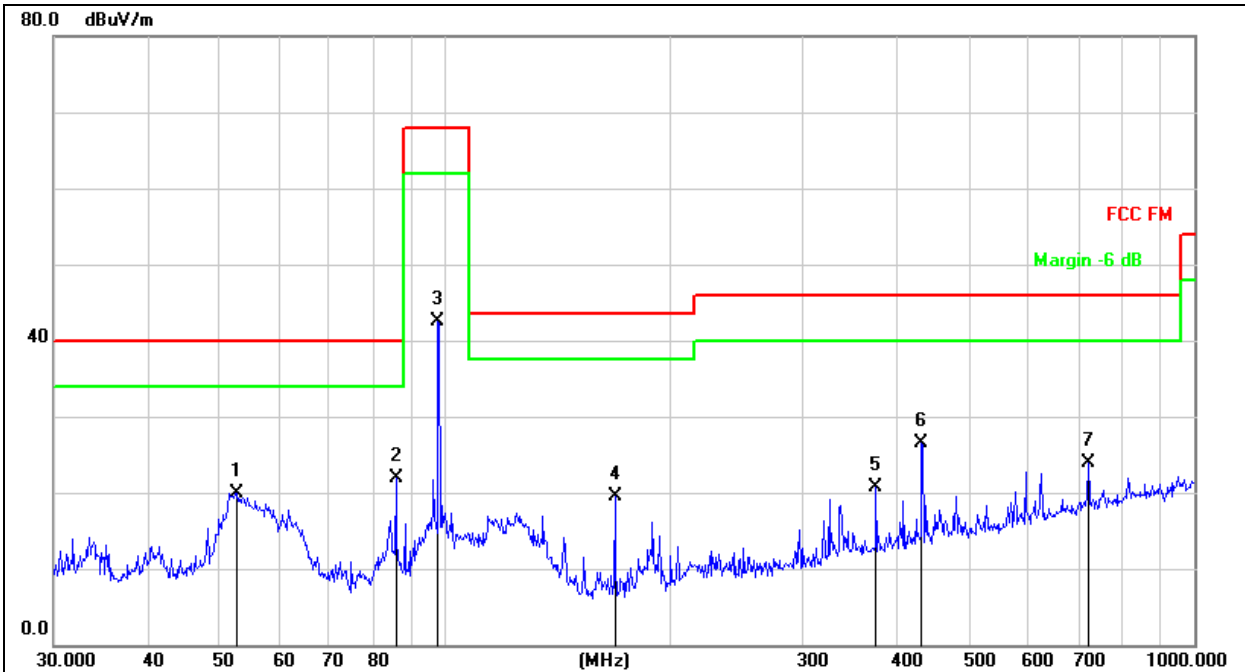

**Remark:**

1. Factor = Antenna Factor + Cable Loss – Pre-amplifier.
2. Measurement=Reading Level+ Correct Factor
3. Over= Measurement-Limit

No.	Mk.	Freq.	Reading Level	Correct Factor	Measurement	Limit	Over	Detector
		MHz	dBuV	dB	dBuV/m	dB/m	dB	
1		52.7600	35.96	-16.00	19.96	40.00	-20.04	QP
2	*	85.8984	42.19	-20.19	22.00	40.00	-18.00	QP
3		97.7983	60.49	-18.08	42.41	68.00	-25.59	peak
4		168.4138	39.15	-19.69	19.46	43.50	-24.04	QP
5		375.9385	33.25	-12.49	20.76	46.00	-25.24	QP
6		432.5457	38.25	-11.74	26.51	46.00	-19.49	QP
7		721.7259	30.65	-6.83	23.82	46.00	-22.18	QP

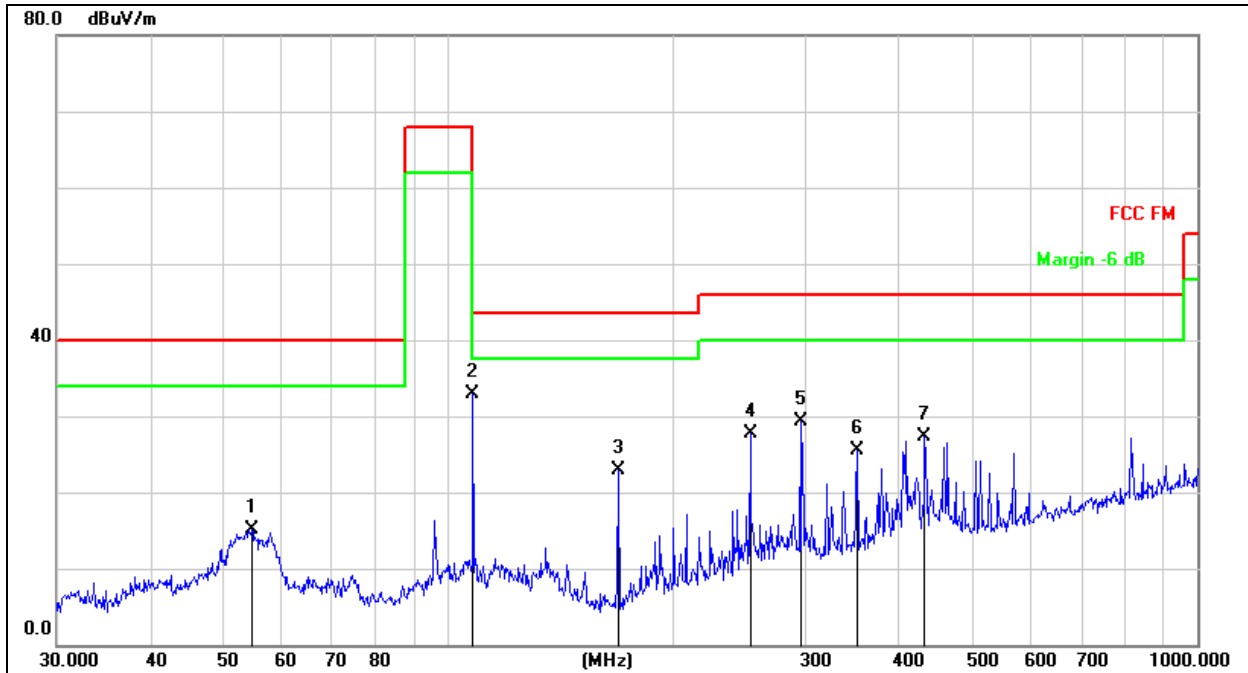

Temperature:	26°C	Relative Humidity:	54%
Pressure:	101 kPa	Test Voltage :	AC120V/60Hz
Test Mode:	Mode 3 (107.9MHz)	Polarization :	Horizontal



**Remark:**

1. Factor = Antenna Factor + Cable Loss – Pre-amplifier.
2. Measurement=Reading Level+ Correct Factor
3. Over= Measurement-Limit

No.	Mk.	Freq.	Reading Level	Correct Factor	Measurement	Limit	Over	Detector
		MHz	dBuV	dB	dBuV/m	dB/m	dB	
1		54.6429	31.39	-16.29	15.10	40.00	-24.90	QP
2		107.8877	51.22	-18.28	32.94	68.00	-35.06	peak
3		168.4138	42.60	-19.69	22.91	43.50	-20.59	QP
4		252.9482	43.39	-15.76	27.63	46.00	-18.37	QP
5	*	295.1469	43.92	-14.70	29.22	46.00	-16.78	QP
6		351.7079	38.36	-12.77	25.59	46.00	-20.41	QP
7		432.5457	38.95	-11.74	27.21	46.00	-18.79	QP

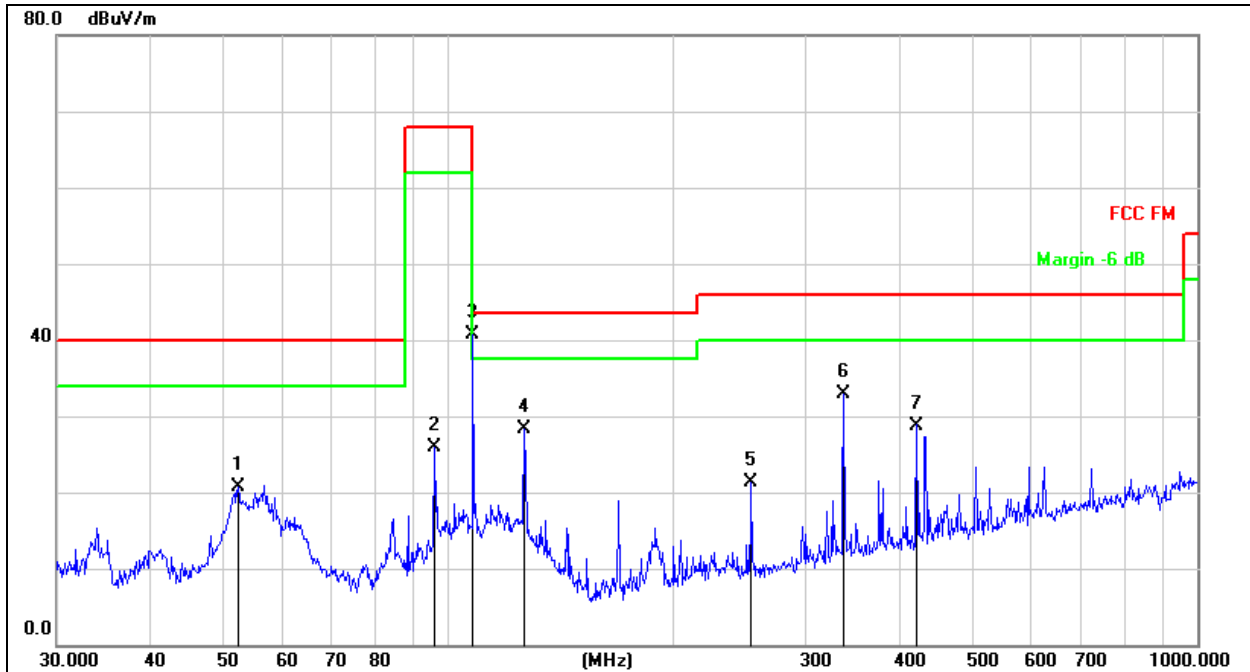

Temperature:	26°C	Relative Humidity:	54%
Pressure:	101 kpa	Test Voltage :	AC 120V/60Hz
Test Mode:	Mode 3 (107.9MHz)	Polarization :	Vertical

**Remark:**

1. Factor = Antenna Factor + Cable Loss – Pre-amplifier.
2. Measurement=Reading Level+ Correct Factor
3. Over= Measurement-Limit

No.	Mk.	Freq. MHz	Reading Level dBuV	Correct Factor dB	Measure- ment dBuV/m	Limit dB/m	Over dB	Detector
1		52.3912	36.73	-15.95	20.78	40.00	-19.22	QP
2		95.7622	44.28	-18.38	25.90	68.00	-42.10	QP
3		107.8877	59.02	-18.28	40.74	68.00	-27.26	peak
4		126.3286	47.80	-19.49	28.31	43.50	-15.19	QP
5		253.8367	37.00	-15.73	21.27	46.00	-24.73	QP
6	*	337.2155	46.24	-13.25	32.99	46.00	-13.01	QP
7		422.0577	40.69	-11.89	28.80	46.00	-17.20	QP

SHENZHEN

**Field Strength Calculation**

Frequency (MHz)	Emission Level		Limits (dB $\mu$ V/m)	Margin (dB)	Horizontal /Vertical
	(dB $\mu$ V/m)				
88.1	34.32	PK	68	-33.68	H
88.1	31.25	AV	48	-16.75	H
88.1	44.51	PK	68	-23.49	V
88.1	41.66	AV	48	-6.34	V
98	32.47	PK	68	-35.53	H
98	30.58	AV	48	-17.42	H
98	42.41	PK	68	-25.59	V
98	40.25	AV	48	-7.75	V
107.9	32.94	PK	68	-35.06	H
107.9	31.59	AV	48	-16.41	H
107.9	40.74	PK	68	-27.26	V
107.9	38.55	AV	48	-9.45	V

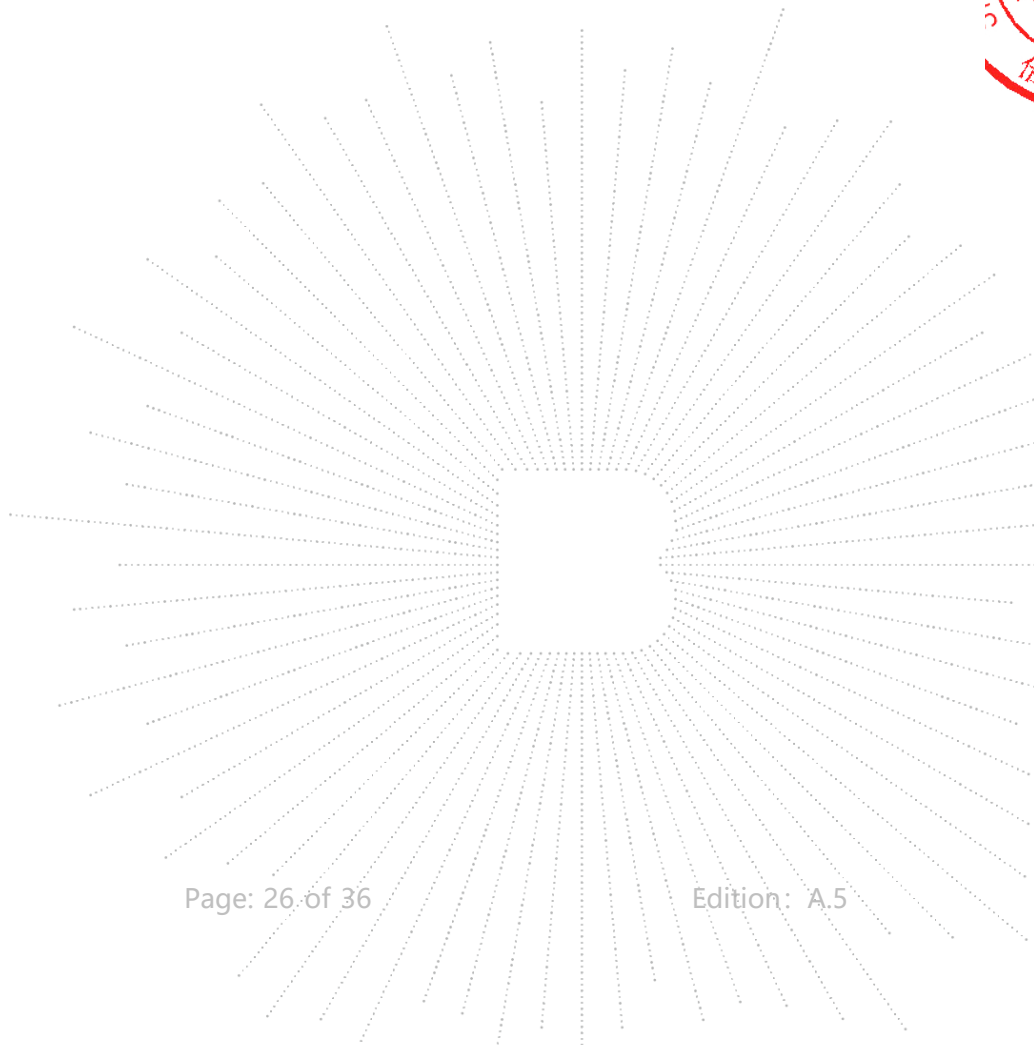

**Radiated Spurious Emission (1GHz to 10th harmonics)**

Polar (H/V)	Frequency	Reading Level	Correct Factor	Measurement	Limits	Over	Detector Type
	(MHz)	(dBuV)	(dB)	(dBuV/m)	(dBuV/m)	(dB)	
V	1053.8	42.24	-7.23	35.01	74	-38.99	PK
V	1053.8	37.32	-7.23	30.09	54	-23.91	AV
V	1176.4	41.14	-7.21	33.93	74	-40.07	PK
V	1176.4	37.47	-7.21	30.26	54	-23.74	AV
V	1315.7	42.32	-6.83	35.49	74	-38.51	PK
V	1315.7	36.65	-6.83	29.82	54	-24.18	AV
H	1053.8	43.74	-7.23	36.51	74	-37.49	PK
H	1053.8	36.28	-7.23	29.05	54	-24.95	AV
H	1176.4	42.36	-7.21	35.15	74	-38.85	PK
H	1176.4	35.23	-7.21	28.02	54	-25.98	AV
H	1315.7	43.32	-6.83	36.49	74	-37.51	PK
H	1315.7	36.25	-6.83	29.42	54	-24.58	AV

**Remark:**

1. Emission Level = Meter Reading + Factor, Factor = Antenna Factor + Cable Loss – Pre-amplifier. Over = Emission Level - Limit
2. If peak below the average limit, the average emission was no test.
3. In restricted bands of operation, The spurious emissions below the permissible value more than 20dB
4. The amplitude of spurious emissions which are attenuated by more than 20dB below the permissible value has no need to be reported.

BCTC  
 3C  
 PPR  
 检测

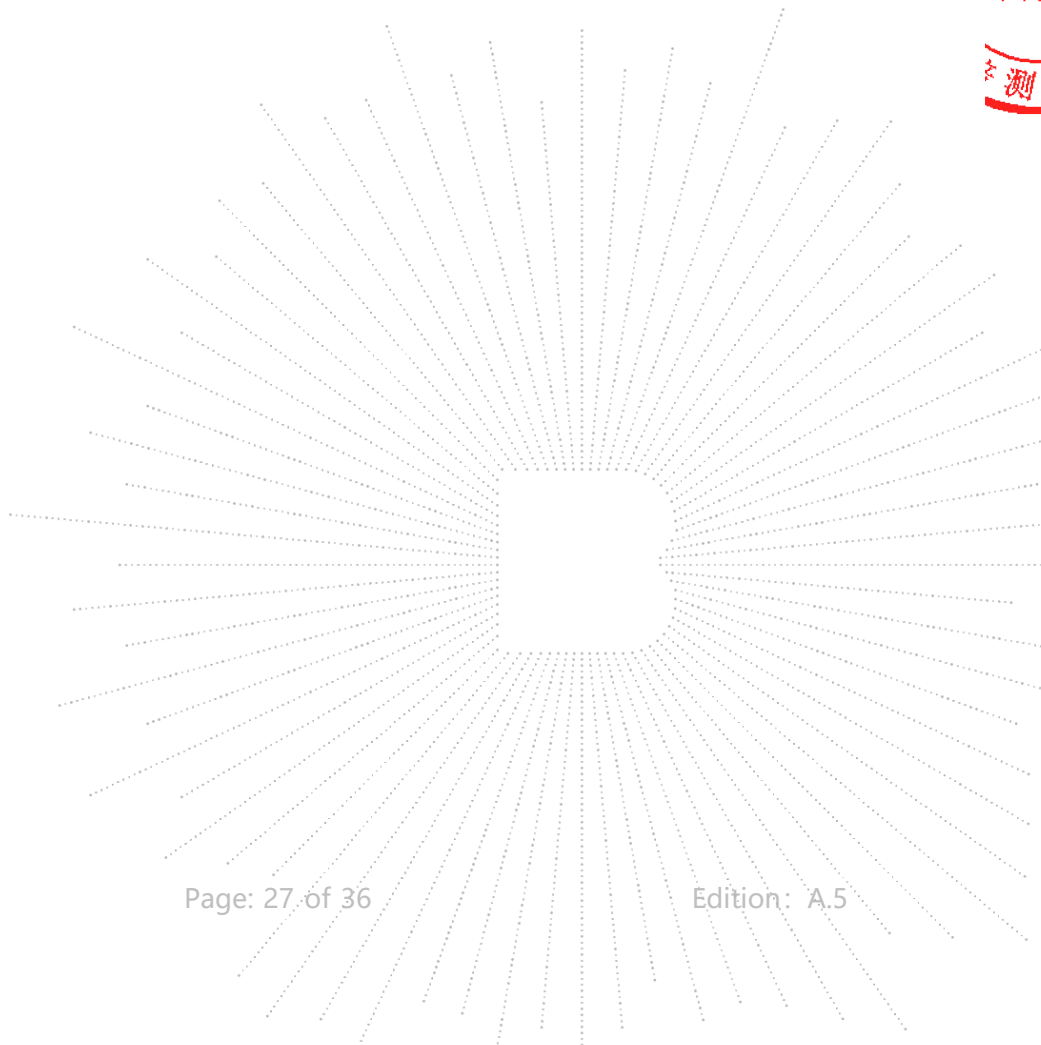

## 8. Bandwidth Test

### 8.1 Applied Procedures / Limit

According to 15.209&15.239 requirement:  
The bandwidth of the emission shall not exceed 200 kHz.

Spectrum Parameter	Setting
Attenuation	Auto
Span Frequency	> Measurement Bandwidth or Channel Separation
RB	30kHz
VB	$\geq$ RBW
Detector	Peak
Trace	Max Hold
Sweep Time	Auto

### 8.2 Test Procedure

- The EUT was directly connected to the spectrum analyzer and antenna output port as show in the block diagram below,
- Spectrum Setting : RBW= 30kHz, VBW $\geq$  RBW, Sweep time = Auto.

### 8.3 Deviation From Standard

No deviation.

### 8.4 Test Setup

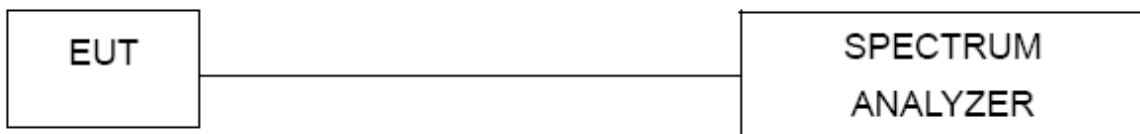

### 8.5 Eut Operation Conditions

The EUT tested system was configured as the statements of 2.4 Unless otherwise a special operating condition is specified in the follows during the testing.

## 8.6 Test Result

Temperature:	26 °C	Relative Humidity:	54%
Pressure:	101kPa	Test Voltage:	DC 5V
Test Mode:	TX Mode		

Frequency (MHz)	20dB bandwidth (kHz)	Limit (kHz)	Result
88.1	93.85	200	PASS
98	93.88	200	PASS
107.9	93.80	200	PASS

88.1 MHz

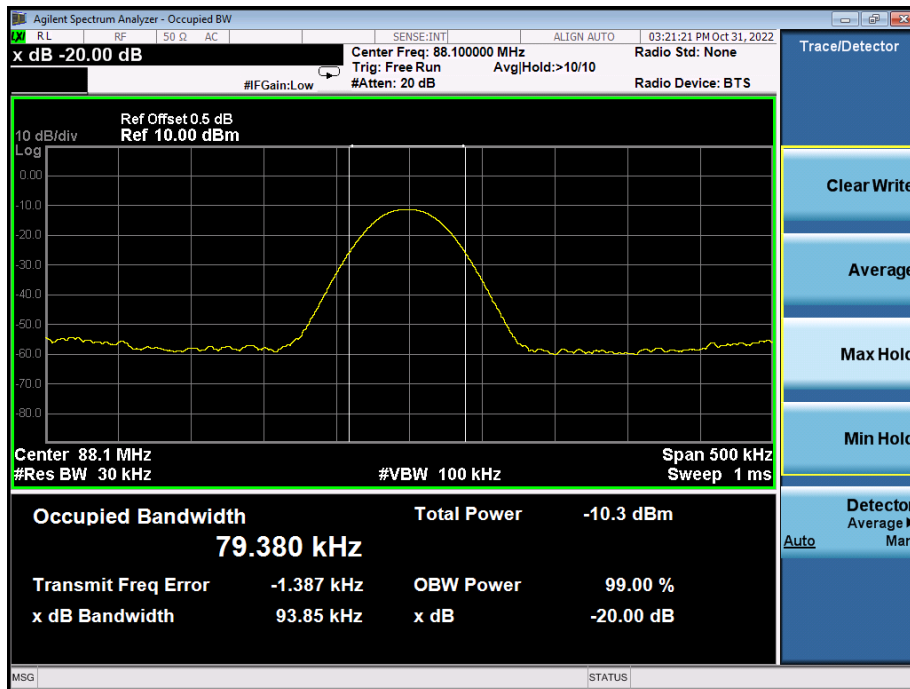

## 98 MHz

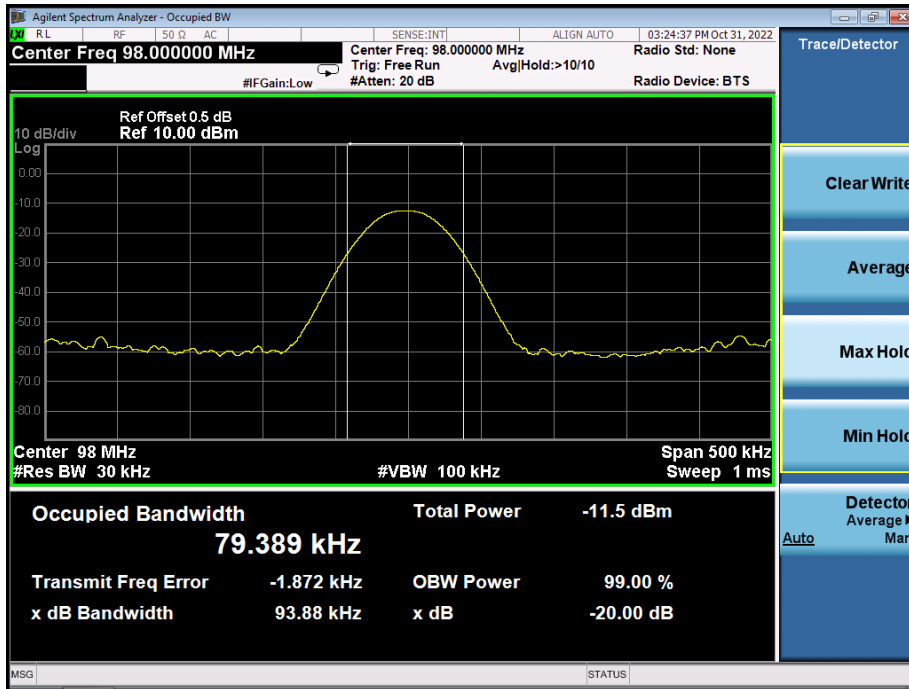

## 107.9 MHz

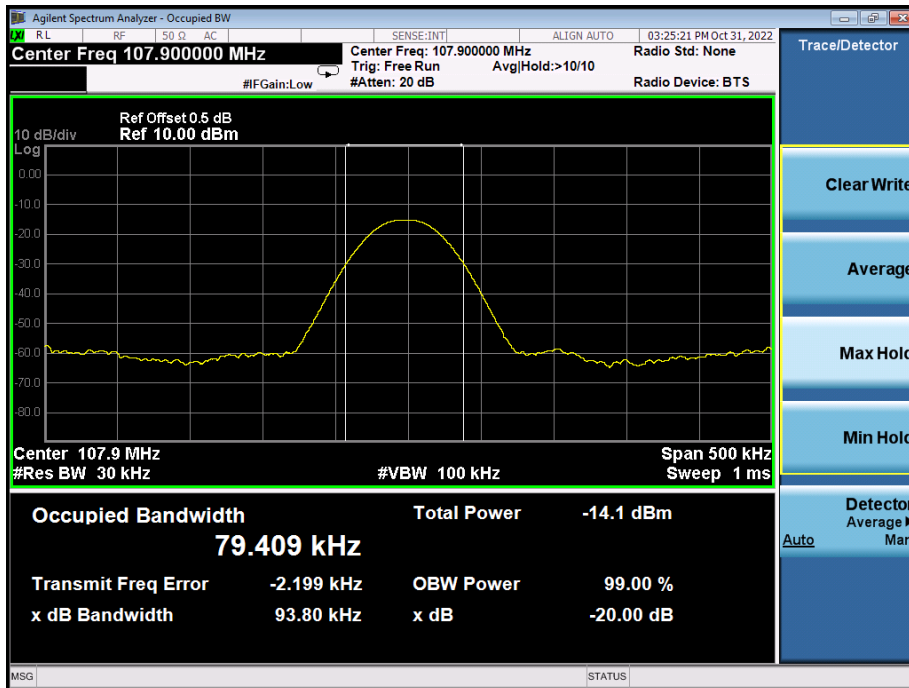

CO., LTD

## 9. Band Edge Measurement

### 9.1 Block Diagram Of Test Setup

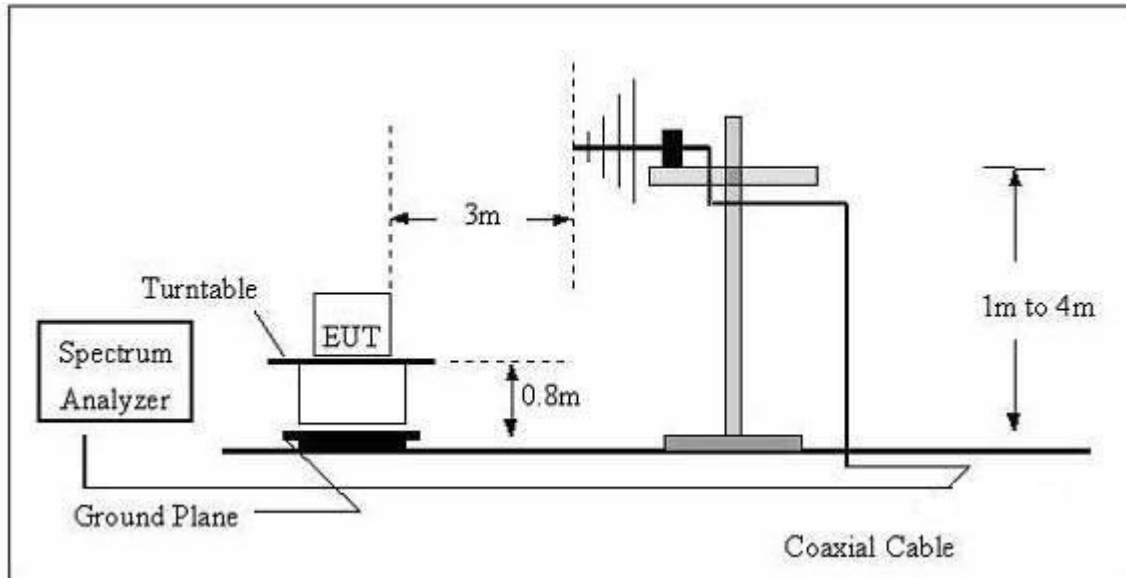

### 9.2 Applicable Standard

FCC Part15 Paragraph 15.209&15.239

Outside the 200kHz band(as well as outside the 88-108MHz band), the general field strength limits listed in 15.209 apply.

### 9.3 Test Procedure

- Check the calibration of the measuring instrument using either an internal calibrator or a known signal from an external generator.
- Position the EUT without connection to measurement instrument. Turn on the EUT and connect its antenna terminal to measurement instrument via a low loss cable. Then set it to any one measured frequency within its operating range, and make sure the instrument is operated in its linear range.
- VBW for Peak, Quasi-peak, or Average Detector Function:  $3 \times \text{RBW}$
- Repeat above procedures until all measured frequencies were complete.

Note:

Both horizontal and vertical antenna polarities were tested and performed pretest to three orthogonal axis. The worst case emissions were reported.

### 9.4 Eut Operation Conditions

The EUT tested system was configured as the statements of 2.4 Unless otherwise a special operating condition is specified in the follows during the testing.

## 9.5 Test Results

Mode	Polar (H/V)	Frequency (MHz)	Reading Level (dBuV/m)	Correct Factor (dB)	Measurement (dBuV/m)	Limits (dBuV/m)	Result	
					QP	QP		
<b>88.1MHz</b>								
FM	H	75.05	35.78	-19.55	16.23	40.00	PASS	
	H	88.00	38.49	-19.58	18.91	40.00	PASS	
	V	75.05	33.64	-19.55	14.09	40.00	PASS	
	V	88.00	36.36	-19.58	16.78	40.00	PASS	
	<b>107.9MHz</b>							
	H	108.00	42.30	-16.67	25.63	43.50	PASS	
	H	109.24	40.39	-16.75	23.64	43.50	PASS	
	V	108.00	37.23	-16.67	20.56	43.50	PASS	
V	109.24	36.73	-16.69	20.04	43.50	PASS		

**Remark:**

1. Emission Level = Meter Reading + Factor,  
Factor = Antenna Factor + Cable Loss – Pre-amplifier.  
Over= Emission Level - Limit
2. If the PK measured levels comply with average limit, then the average level were deemed to comply with average limit.
3. In restricted bands of operation, The spurious emissions below the permissible value more than 20dB
4. The amplitude of spurious emissions which are attenuated by more than 20dB below the permissible value has no need to be reported.

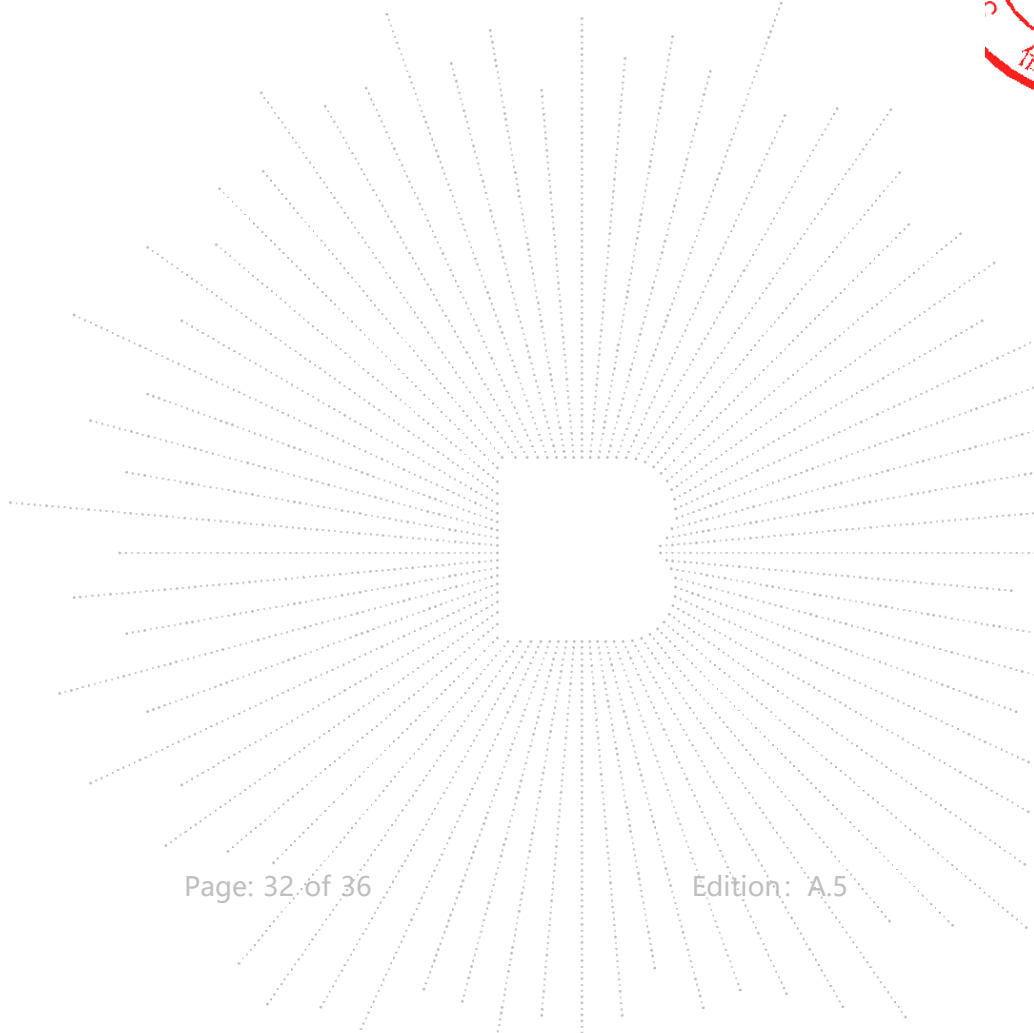



## 10. Antenna Requirement

### 10.1 Standard Requirement

15.203 requirement: For intentional device, according to 15.203: an intentional radiator shall be designed to ensure that no antenna other than that furnished by the responsible party shall be used with the device.

### 10.2 EUT Antenna

The EUT antenna is the FPC antenna. It comply with the standard requirement.

TC  
3C  
PPR  
測

### 11. EUT Photographs

EUT Photo

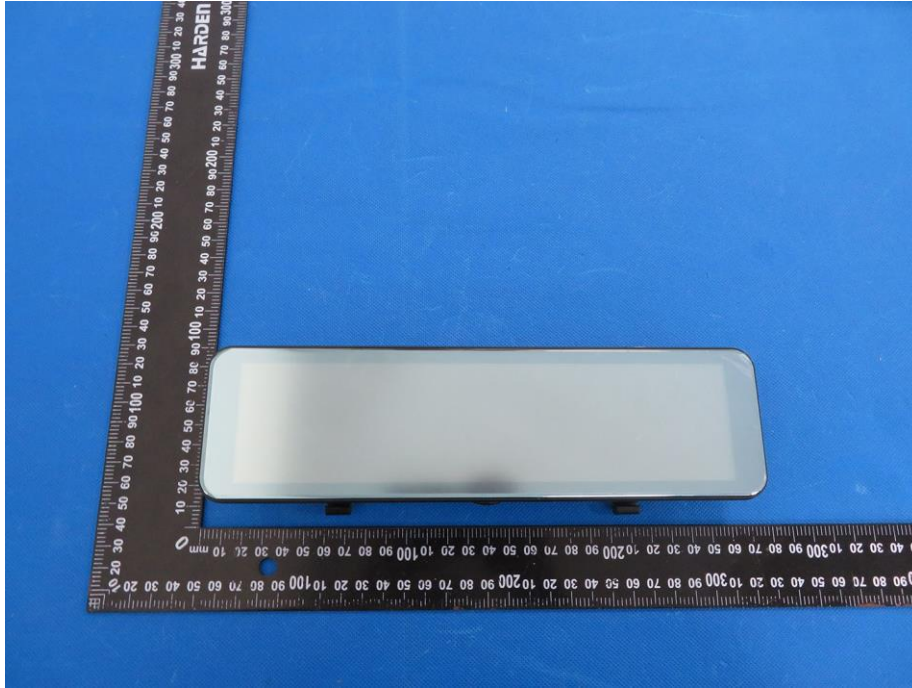

NOTE: Appendix-Photographs Of EUT Constructional Details

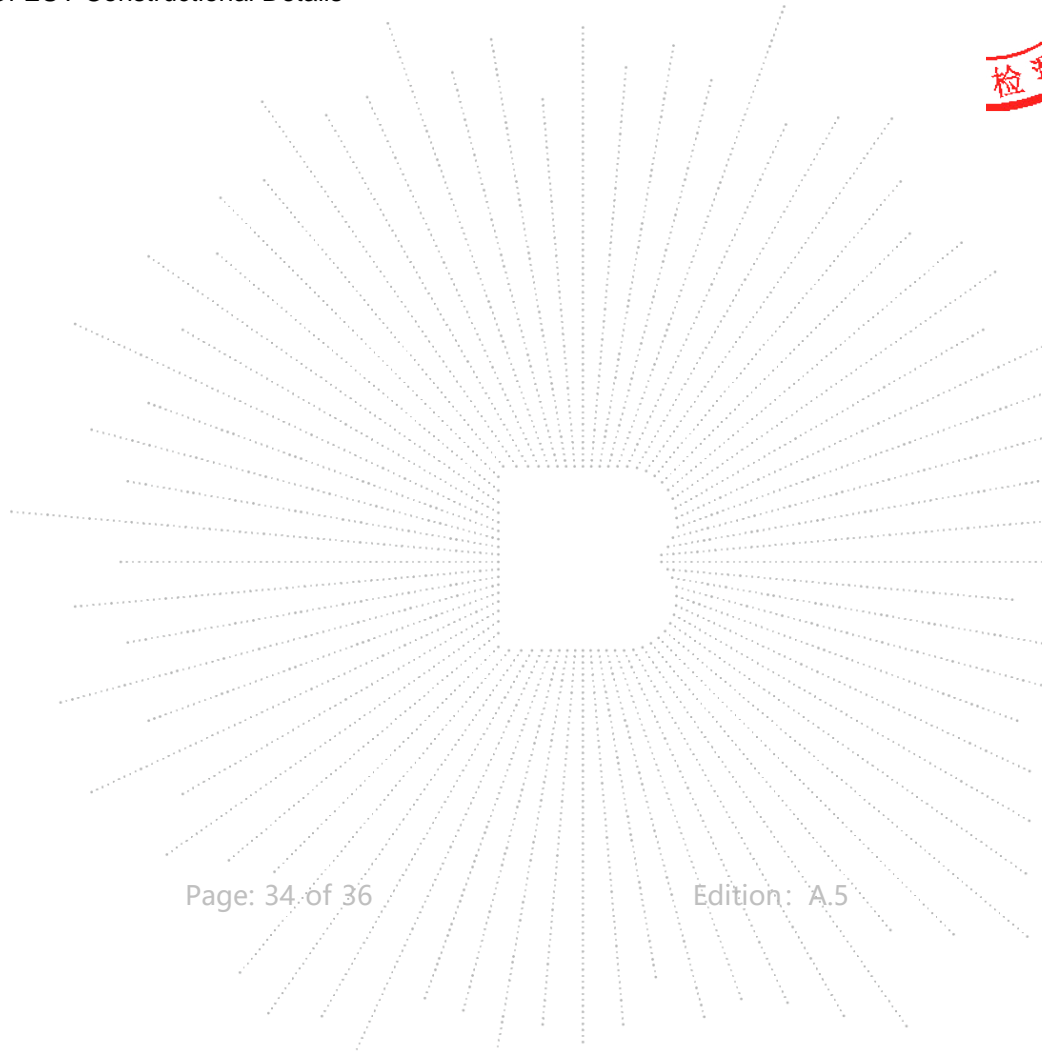

## 12. EUT Test Setup Photographs

Conducted Measurement Photos



Radiated Measurement Photos

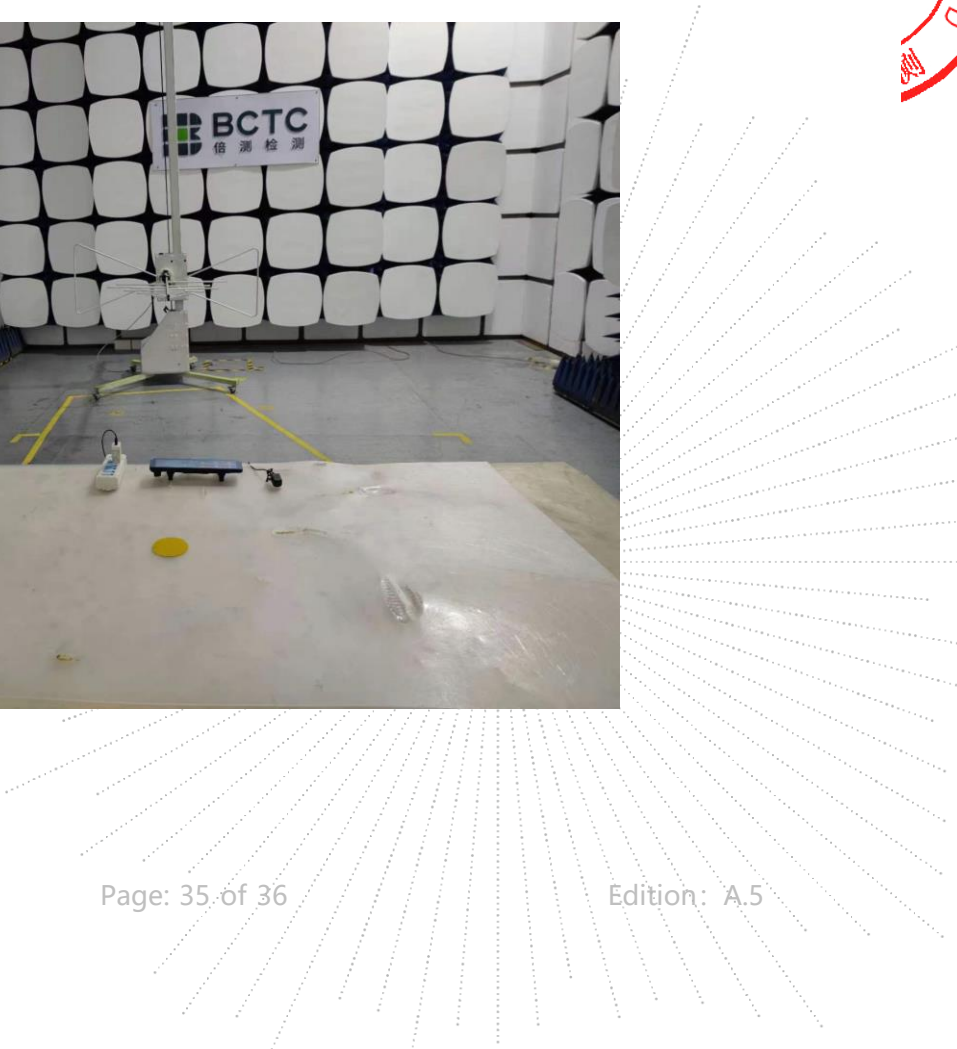
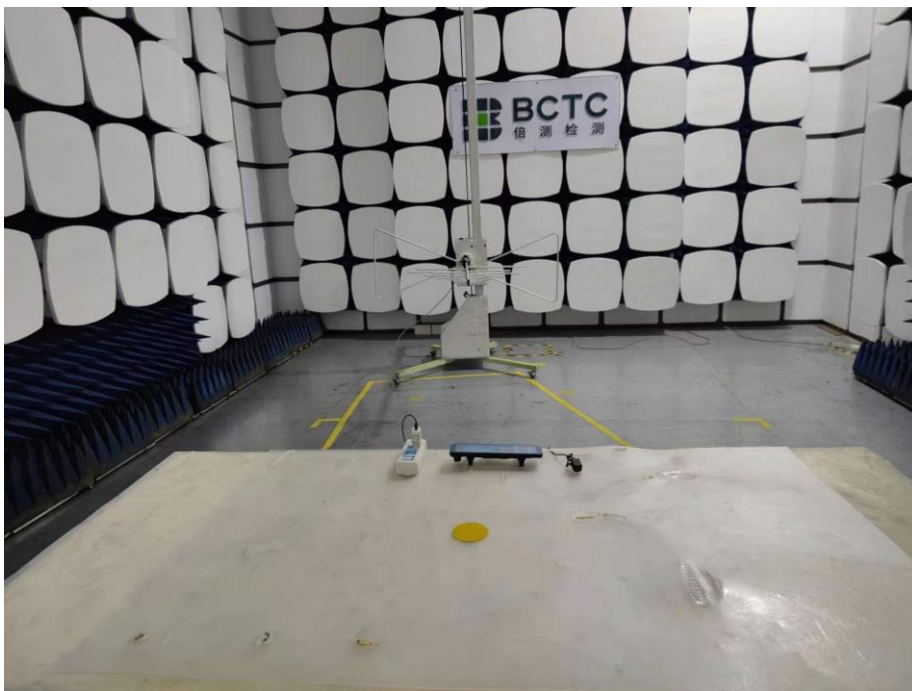

## STATEMENT

1. The equipment lists are traceable to the national reference standards.
2. The test report can not be partially copied unless prior written approval is issued from our lab.
3. The test report is invalid without the "special seal for inspection and testing".
4. The test report is invalid without the signature of the approver.
5. The test process and test result is only related to the Unit Under Test.
6. Sample information is provided by the client and the laboratory is not responsible for its authenticity.
7. The test report without CMA mark is only used for scientific research, teaching, enterprise product development and internal quality control purposes.
8. The quality system of our laboratory is in accordance with ISO/IEC17025.
9. If there is any objection to this test report, the client should inform issuing laboratory within 15 days from the date of receiving test report.

Address:

1-2/F., Building B, Pengzhou Industrial Park, No.158, Fuyuan 1st Road, Zhancheng, Fuhai Subdistrict, Bao'an District, Shenzhen, Guangdong, China

TEL: 400-788-9558

P.C.: 518103

FAX: 0755-33229357

Website: <http://www.chnbctc.com>

E-Mail: [bctc@bctc-lab.com.cn](mailto:bctc@bctc-lab.com.cn)

\*\*\*\*\* END \*\*\*\*\*