

# TEST REPORT

Verified code: 523894

<b>Report No.:</b>	E202003304805-5	<b>Application No.:</b>	E202003304805
<b>Client:</b>	Shenzhen Malide Technology Co., Ltd.		
<b>Address:</b>	Room 201, No.26A, Xin'E Industrial Zone, E'GongLing, Pinghu Street, Longgang District, Shenzhen, Guangdong Province		
<b>Sample Description:</b>	Internal TPMS		
<b>Model:</b>	MLD-B06		
<b>Test Location:</b>	Guangzhou GRG Metrology & Test Co., Ltd.		
<b>Test Specification:</b>	CFR 47 FCC Part 15 Subpart C 10-1-2019 Edition ANSI C63.10:2013		
<b>Issue Date:</b>	2020/06/19		
<b>Test Result:</b>	Pass		
<b>Prepared By:</b> Test Engineer  <i>Wu Haoting</i>	<b>Reviewed By:</b> Technical Manager  <i>Wu Chengrong</i>	<b>Approved By:</b> Manager  <i>Zhu Yan</i>	
<b>Other Aspects:</b>			
Note: /			
Abbreviations: ok / P = passed; fail / F = failed; n.a. / N = not applicable;			
The test result in this test report refers exclusively to the presented test sample. This report shall not be reproduced except in full, without the written approval of GRGT.			



## **DIRECTIONS OF TEST**

1. This company carries out test task according to the national regulation of verifications which can be traced to National Primary Standards and BIPM.
2. The test report merely corresponds to the test sample. It is not permitted to copy extracts of these test result without the written permission of the test laboratory.
3. If there is any objection concerning the test, the client should inform the laboratory within 15 days from the date of receiving the test report.

## TABLE OF CONTENTS

<b>1. TEST RESULT SUMMARY .....</b>	<b>4</b>
<b>2. GENERAL DESCRIPTION OF EUT.....</b>	<b>5</b>
2.1. APPLICANT .....	5
2.2. MANUFACTURER .....	5
2.3. FACTORY .....	5
2.4. BASIC DESCRIPTION OF EQUIPMENT UNDER TEST .....	5
<b>3. LABORATORY AND ACCREDITATIONS .....</b>	<b>6</b>
3.1. LABORATORY .....	6
3.2. ACCREDITATIONS .....	6
3.3. MEASUREMENT UNCERTAINTY .....	6
<b>4. LIST OF USED TEST EQUIPMENT AT GRGT.....</b>	<b>7</b>
<b>5. RADIATED SPURIOUS EMISSIONS .....</b>	<b>8</b>
5.1. LIMITS .....	8
5.2. TEST PROCEDURES .....	8
5.3. TEST SETUP .....	9
5.4. DATA SAMPLE .....	10
5.5. TEST RESULTS .....	11
<b>6. 20DB BANDWIDTH.....</b>	<b>14</b>
6.1. LIMITS .....	14
6.2. TEST PROCEDURES .....	14
6.3. TEST SETUP .....	14
6.4. TEST RESULTS .....	14
<b>7. TRANSMISSION TIME .....</b>	<b>15</b>
7.1. LIMITS .....	15
7.2. TEST PROCEDURES .....	15
7.3. TEST SETUP .....	15
7.4. TEST RESULTS .....	15
<b>APPENDIX A: PHOTOGRAPH OF THE TEST ARRANGEMENT.....</b>	<b>18</b>

## 1. TEST RESULT SUMMARY

Section B of FCC Part 15.231			
Standard	Item	Limit / Severity	Result
Part 15,Subpart C (15.231)	Conducted Emissions	§15.203	N/A <sup>1)</sup>
	Transmission Time	§15.231 §15.231(a) (3)	PASS
	20DB Bandwidth	§15.231 (c)	PASS
	Radiated Spurious Emission	§15.231(b)	PASS

Note. 1: The EUT was powered by 1\*DC 3V type “CR2050HR” Battery.

## 2. GENERAL DESCRIPTION OF EUT

### 2.1. APPLICANT

Name: Shenzhen Malide Technology Co., Ltd.  
Address: Room 201, No.26A, Xin'E Industrial Zone, E'GongLing, Pinghu Street, Longgang District, Shenzhen, Guangdong Province

### 2.2. MANUFACTURER

Name: Shenzhen Malide Technology Co., Ltd.  
Address: Room 201, No.26A, Xin'E Industrial Zone, E'GongLing, Pinghu Street, Longgang District, Shenzhen, Guangdong Province

### 2.3. FACTORY

Name : Shenzhen Malide Technology Co., Ltd.  
Address : Room 201, No.26A, Xin'E Industrial Zone, E'GongLing, Pinghu Street, Longgang District, Shenzhen, Guangdong Province

### 2.4. BASIC DESCRIPTION OF EQUIPMENT UNDER TEST

Equipment: Internal TPMS  
Model No.: MLD-B06  
Adding Model N/A  
Trade Name: Malide  
FCC ID: 2AV7VMLD-B06  
Power supply DC 3V powered by 1\*DC 3V type "CR2050HR" Battery.  
Frequency Range 433.92MHz  
Max Antenna gain: Integrated Antenna, -3.02dBi (Max)  
Sample submitting way :  Provided by customer  Sampling  
Type of Modulation: FSK  
Temperature Range: -40 °C ~ +125 °C  
Hardware Version: V2.0  
Software Version: V3.0  
Note: N/A

### 3. LABORATORY AND ACCREDITATIONS

#### 3.1. LABORATORY

The tests & measurements refer to this report were performed by Shenzhen EMC Laboratory of Guangzhou GRG Metrology & Test Co., Ltd.

Add : Address: No.1301 Guanguang Road Xinlan Community, Guanlan Street,  
Longhua District Shenzhen, 518110, People's Republic of China

P.C. : 518000

Tel : 0755-61180008

Fax : 0755-61180008

#### 3.2. ACCREDITATIONS

A2LA	Certificate Number 2861.01
------	----------------------------

#### 3.3. MEASUREMENT UNCERTAINTY

Where relevant, the following measurement uncertainty levels have been estimated for tests performed on the EUT as specified in CISPR 16-4-2:

Measurement		Frequency	Uncertainty
Radiated Emission	Horizontal	30MHz~1000MHz	4.3dB
		1GHz~18GHz	5.6dB
	Vertical	30MHz~1000MHz	4.3dB
		1GHz~18GHz	5.6dB

This uncertainty represents an expanded uncertainty factor of  $k=2$ .

**4. LIST OF USED TEST EQUIPMENT AT GRGT**

Name of Equipment	Manufacturer	Model	Serial Number	Calibration Due
<b>Radiated Spurious Emission</b>				
EMI TEST Receiver	ROHDE&SCHW ARZ	ESU26	EMC26-G260	2020-07-16
EXA signal analyzer	Agilent	N9010A	MY52221469	2021-05-16
Bilog Antenna	Schwarzbeck	VULB9160	VULB9160-3401	2020-11-27
Horn Antenna	Schwarzbeck	BBHA9120	D286	2020-11-27
Amplifier	tonscend	TAP9E6343	AP20E806065	/
Amplifier	tonscend	TAP01018048	AP20E806075	/
Test SW	tonscend	Js1120-2		
<b>20dB bandwidth/Duty cycle/Transmission time</b>				
Spectrum Analyzer	Agilent	N9020A	MY50510140	2021-01-11
DC power supply	RIGOL	DP711	DP7A204401156	2021-05-17
Signal Generator	Agilent	N5171B	MY57281462	2021-04-12

## 5. RADIATED SPURIOUS EMISSIONS

### 5.1. LIMITS

§15.231(b) In addition to the provisions of §15.205, the field strength of emissions from intentional radiators operated under this section shall not exceed the following:

Fundamental frequency (MHz)	Field strength of fundamental (microvolts/meter)	Field strength of spurious emission (microvolts/meter)
40.66-40.70	2,250	225
70-130	1,250	125
130-174	<sup>1</sup> 1,250 to 3,750	<sup>1</sup> 125 to 375
174-260	3,750	375
260-470	<sup>1</sup> 3,750 to 12,500	<sup>1</sup> 375 to 1,250
Above 470	12,500	1,250

1. \*\* linear interpolations

[Where F is the frequency in MHz, the formulas for calculating the maximum permitted fundamental field strengths are as follows: for the band 130-174 MHz, uV/m at 3 meters = 56.81818(F) - 6136.3636; for the band 260-470 MHz, uV/m at 3 meters = 41.6667(F) - 7083.3333. The maximum permitted unwanted emission level is 20 dB below the maximum permitted fundamental level.]

§15.231(b)(3) The limits on the field strength of the spurious emissions in the above table are based on the fundamental frequency of the intentional radiator. Spurious emissions shall be attenuated to the average (or, alternatively, CISPR quasi-peak) limits shown in this table or to the general limits shown in §15.209, whichever limit permits a higher field strength.

Frequency (MHz)	Quasi-peak(μV/m)	Measurement distance(m)	Quasi-peak(dBμV/m)@distance 3m
0.009-0.490	2400/F(kHz)	300	53.8~88.5
0.490-1.705	24000/F(kHz)	30	43~53.8
1.705-30.0	30	30	49.5
30 ~ 88	100	3	40
88~216	150	3	43.5
216 ~ 960	200	3	46
Above 960	500	3	54

NOTE: (1) The lower limit shall apply at the transition frequencies.

### 5.2. TEST PROCEDURES

- 1) The EUT was placed on the top of a rotating table 0.8 meters (for below 1GHz) / 1.5 meters (for above 1GHz) above the ground at a 3 meters semi-anechoic chamber. The table was rotated 360 degrees to determine the position of the highest radiation.
- 2) The EUT was set 3 meters away from the interference-receiving antenna, which was mounted on the top of a variable-height antenna tower.
- 3) Height of receiving antenna is varied from one meter to four meters above the ground to determine the maximum value of the field strength. Both horizontal and vertical polarizations of the antenna are set to make the measurement.



- 4) The test-receiver system was set to Peak Detect Function and Specified Bandwidth with Maximum Hold Mode.
- 5) The test-receiver system was set to Peak Detect Function and Specified Bandwidth with Maximum Hold Mode.
- 6) If the emission level of the EUT in peak mode was lower than the limit specified, then testing could be stopped and the peak values of the EUT would be reported. Otherwise the emissions would be re-tested one by one using peak, quasi-peak or average method as specified and then reported in a data sheet.

### 5.3. TEST SETUP

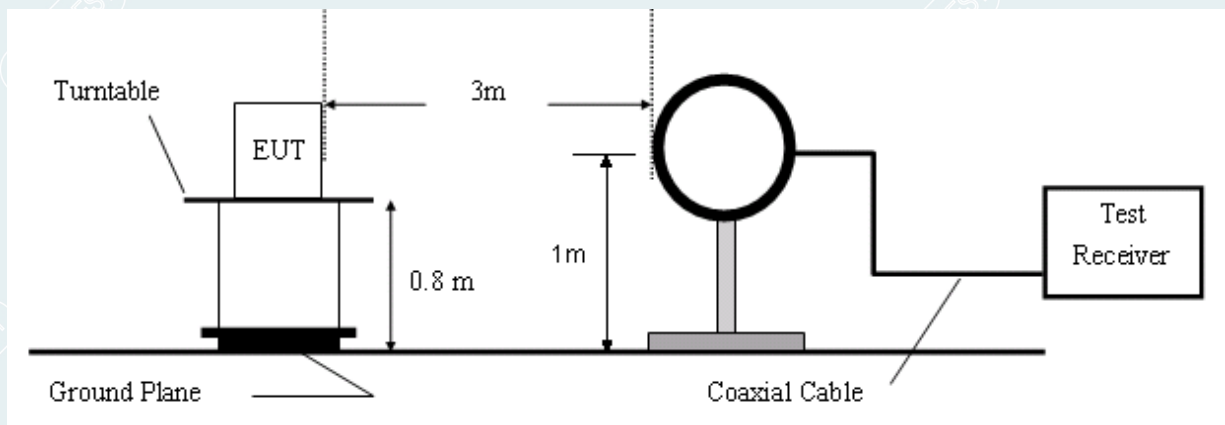

Figure 1. 9KHz to 30MHz radiated emissions test configuration

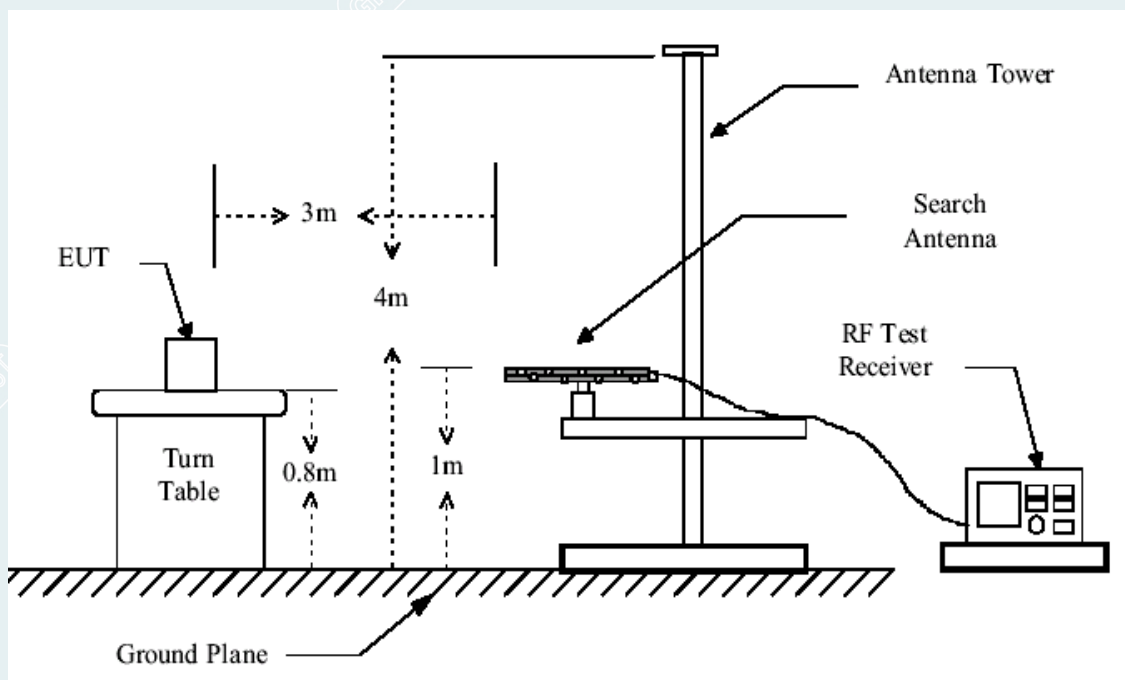

Figure 2. 30MHz to 1GHz radiated emissions test configuration

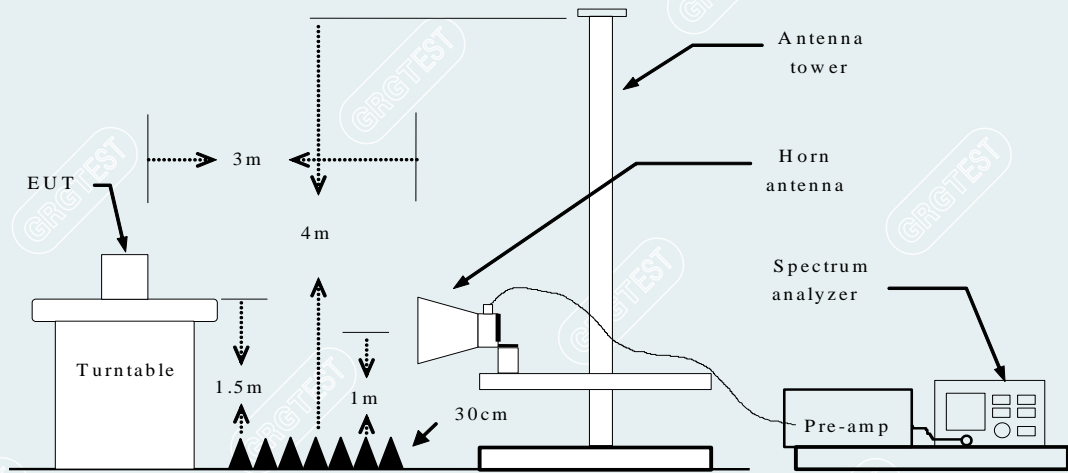

Figure 3. Above 1GHz radiated emissions test configuration

### 5.4. DATA SAMPLE

#### Below 1GHz

Frequency (MHz)	Reading (dBuV)	Correction Factor (dB/m)	Result (dBuV/m)	Limit (dBuV/m)	Margin (dB)	Antenna Pole (V/H)	Remark
XXX.XXXX	37.47	-16.41	21.06	40.00	-18.94	V	QP

#### Above 1GHz

Frequency (MHz)	Reading (dBuV)	Correction Factor (dB/m)	Result (dBuV/m)	Limit (dBuV/m)	Margin (dB)	Antenna Pole (V/H)	Remark
XXXX.XXXX	55.54	4.56	60.10	74.00	-13.90	V	Peak
XXXX.XXXX	29.66	4.56	34.22	54.00	-19.78	V	AVG

- Frequency (MHz) = Emission frequency in MHz
- Reading (dBuV) = Uncorrected Analyzer / Receiver reading
- Correction Factor (dB/m) = Antenna factor + Cable loss – Amplifier gain
- Result (dBuV/m) = Reading (dBuV) + Corr. Factor (dB/m)
- Limit (dBuV/m) = Limit stated in standard
- Margin (dB) = Result (dBuV/m) – Limit (dBuV/m)
- Q.P. = Quasi-peak Reading
- Peak = Peak Reading
- AVG = Average Reading

## 5.5. TEST RESULTS

### *Fundamental:*

Frequency	Reading	Correct	Result	Limit	Margin	Antenna Pole(V/H)	Remark
(MHz)	(dBuV/m)	Factor(dB/m)	(dBuV/m)	(dBuV/m)	(dB)		
433.5200	59.35	-22.29	37.06	100.83	-63.77	V	peak
433.5200	65.34	-22.60	42.74	100.83	-58.09	H	peak

Frequency	PK Result	Duty Cycle Correction	Result	Limit	Margin	Antenna Pole(V/H)	Remark
(MHz)	(dBuV/m)	Factor(dB)	(dBuV/m)	(dBuV/m)	(dB)		
433.5200	37.06	-12.02	25.04	80.83	-55.79	V	AVG
433.5200	42.74	-12.02	30.72	80.83	-50.11	H	AVG

### Remark:

1.  $AVG = Peak + 20 \log(Duty\ Cycle)$
2. Duty Cycle Correction Factor:  $20 \log(0.26) = -12.02$
3. Duty Cycle = On time/Total time =  $26/100 = 0.26\%$

### Radiated Spurious Emission

#### For 9 kHz to 30MHz

The amplitude of spurious emissions which are attenuated by more than 20dB below the permissible value has no need to be reported.

30MHz – 1GHz

#### Vertical

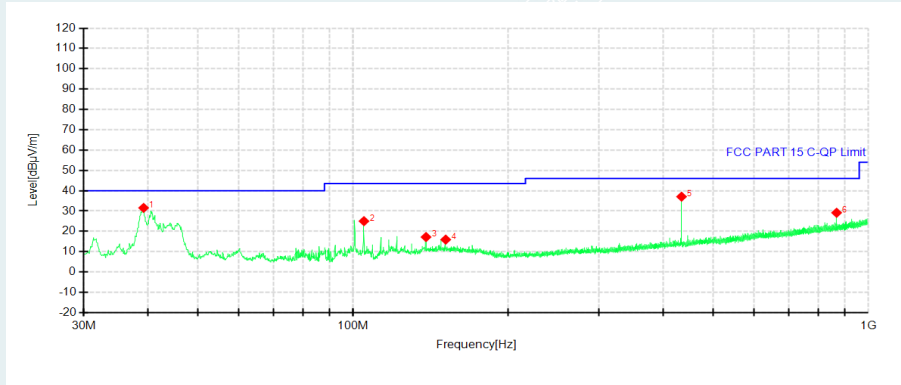

Freq. [MHz]	Level [dBµV/m]	Factor [dB]	Limit [dBµV/m]	Margin [dB]	Height [cm]	Angle [°]	Polarity
39.2150	31.56	-29.65	40.00	8.44	100	281	Vertical
104.9810	25.03	-31.02	43.50	18.47	200	3	Vertical
138.5430	17.20	-27.42	43.50	26.30	100	233	Vertical
151.2500	15.95	-26.33	43.50	27.55	200	184	Vertical
867.8860	29.15	-14.17	46.00	16.85	100	298	Vertical

#### Horizontal

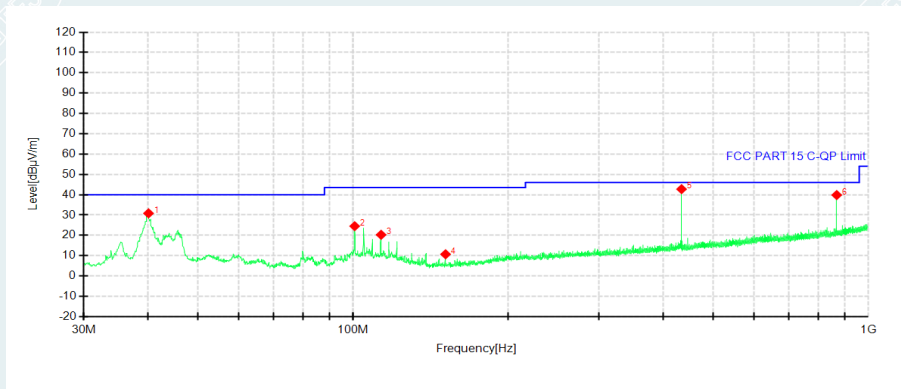

Freq. [MHz]	Level [dBµV/m]	Factor [dB]	Limit [dBµV/m]	Margin [dB]	Height [cm]	Angle [°]	Polarity
40.0880	30.84	-29.70	40.00	9.16	100	174	Vertical
100.7130	24.53	-29.89	43.50	18.97	100	267	Vertical
113.3230	20.28	-30.28	43.50	23.22	100	60	Vertical
151.1530	10.69	-32.13	43.50	32.81	100	352	Vertical
868.1770	39.85	-14.86	46.00	6.15	100	45	Vertical

**Emission above 1GHz:**

According to C63.10, if the peak (or quasi-peak) measured value complies with the average limit, it is unnecessary to perform an average measurement, so AV emission value did not show in below table if the peak value complies with average limit.

Mode: TX

Test channel (433.92 MHz)

Frequency (MHz)	Result PK (dBuV/m)	Result AV (dBuV/m)	Correct Factor(dB/m)	Duty Cycle Factor (dB)	Limit (dBuV/m)	Margin (dB)	Height [cm]	Angle [°]	Pole
1301.7500	54.68		-23.47		74.00	19.32	100	8	Vertical
1301.7500	54.68	42.64	-23.47	-12.04	54.00	11.36	100	8	Vertical
1746.0000	35.67		-21.71		74.00	38.33	100	136	Vertical
2127.2500	34.65		-20.19		74.00	39.35	200	2	Vertical
3127.0000	36.33		-16.95		74.00	37.67	200	227	Vertical
3617.0000	36.89		-14.87		74.00	37.11	200	257	Vertical
4706.0000	39.00		-11.63		74.00	35.00	200	67	Vertical
1301.7500	60.84		-23.47		74.00	13.16	100	201	Horizontal
1301.7500	60.84	48.8	-23.47	-12.04	54.00	5.20	100	201	Horizontal
1736.0000	34.55		-21.79		74.00	39.45	200	78	Horizontal
2536.2500	36.12		-18.55		74.00	37.88	100	302	Horizontal
3262.7500	36.25		-16.64		74.00	37.75	200	357	Horizontal
3597.2500	36.24		-14.86		74.00	37.76	100	196	Horizontal
4692.2500	39.23		-11.72		74.00	34.77	200	43	Horizontal

## 6. 20DB BANDWIDTH

### 6.1. LIMITS

§15.231 (c) The bandwidth of the emission shall be no wider than 0.25% of the center frequency for devices operating above 70 MHz and below 900 MHz. For devices operating above 900 MHz, the emission shall be no wider than 0.5% of the center frequency. Bandwidth is determined at the points 20 dB down from the modulated carrier.

### 6.2. TEST PROCEDURES

- 1) Set resolution bandwidth (RBW) =2kHz.Set the video bandwidth (VBW) ≥ 3 x RBW. Detector = Peak. Trace mode = max hold. Sweep = auto couple. Allow the trace to stabilize, record 20dB bandwidth value.
- 2) Repeat above procedures until all frequencies measured were complete.

### 6.3. TEST SETUP



### 6.4. TEST RESULTS

Test mode:

Channel	Frequency(MHz)	Bandwidth (kHz)	Limit (kHz)	Test Result
	433.92	156.6	1084.8	PASS

#### Test Plot

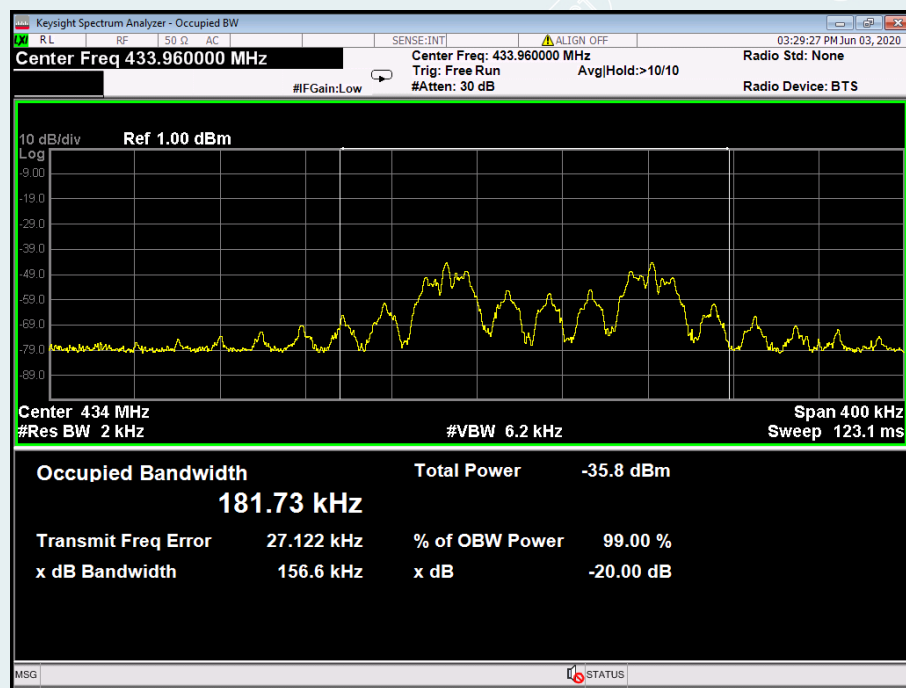

## 7. TRANSMISSION TIME

### 7.1. LIMITS

§15.231 (e) (3) Periodic transmissions at regular predetermined intervals are not permitted. However, polling or supervision transmissions, including data, to determine system integrity of transmitters used in security or safety applications are allowed if the total duration of transmissions does not exceed more than two seconds per hour for each transmitter. There is no limit on the number of individual transmissions, provided the total transmission time does not exceed two seconds per hour.

§15.231 (e) devices operated under the provisions of this paragraph shall be provided with a means for automatically limiting operation so that the duration of each transmission shall not be greater than one second and the silent period between transmissions shall be at least 30 times the duration of the transmission but in no case less than 10 seconds.

§15.231 (a) for this periodic operation:

- (1) A manually operated transmitter shall employ a switch that will automatically deactivate the transmitter within not more than 5 seconds of being released.
- (2) A transmitter activated automatically shall cease transmission within 5 seconds after activation.

### 7.2. TEST PROCEDURES

- 1) The spectrum analyzer resolution bandwidth that is  $\leq$ EBW. So we test the Maximum Conducted Output Power — Integrated band power method.
- 2) Set Set the analyzer span = 0Hz. RBW = 100kHz. Set VBW  $\geq$  3 x RBW. Detector = Peak. Sweep = Adjust according to actual conditions.
- 3) Allow the trace to stabilize, record value.

### 7.3. TEST SETUP

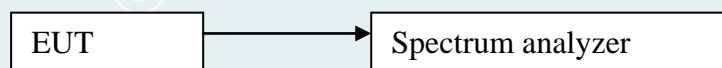

### 7.4. TEST RESULTS

#### Test Data

Frequency (MHz)	Transmission Time (s)	Limit (s)	Result
433.92	0.220	1	Pass

Frequency (MHz)	Silent period (s)	Limit (s)	Result
433.92	14.85	>10	Pass

### Test Plot

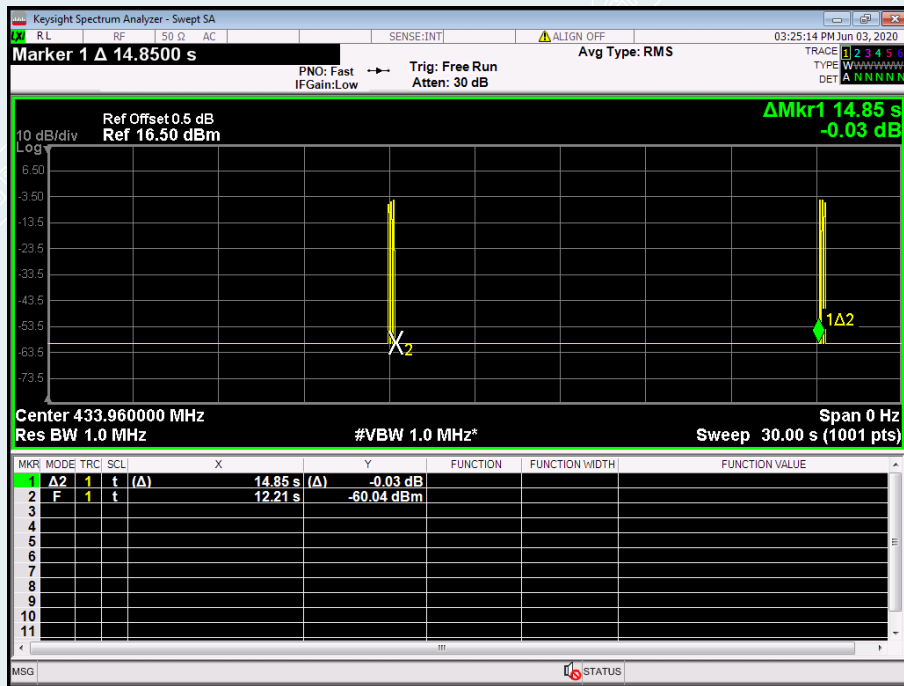
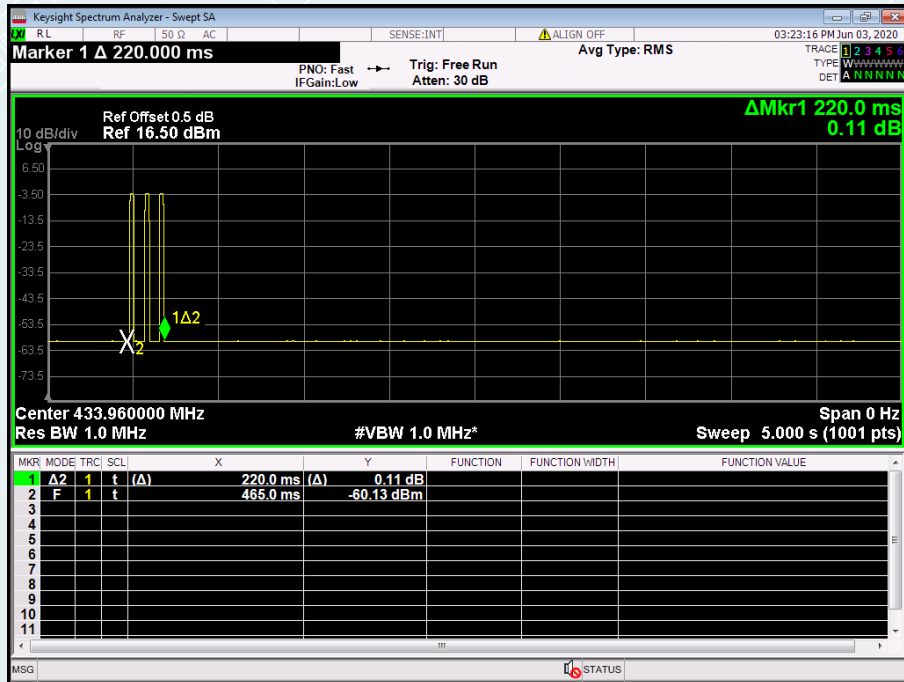



**Duty Cycle:**

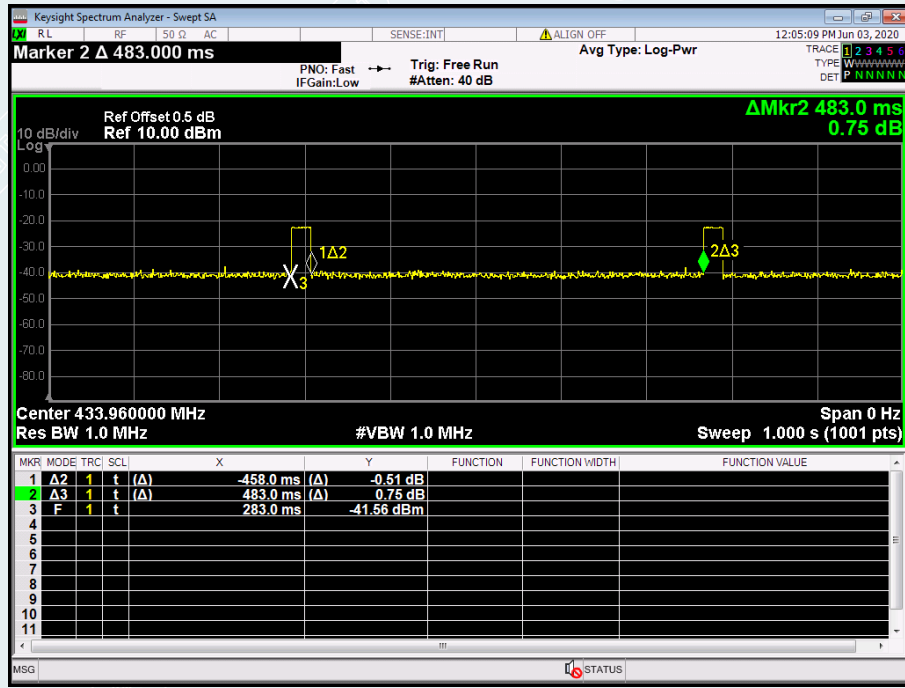

Remark:

1. On time: 25ms
2. Duty Cycle = On time/Total time (100ms) = 25ms/100ms = 25%

## APPENDIX A: PHOTOGRAPH OF THE TEST ARRANGEMENT

RSE (Below 1GHz)

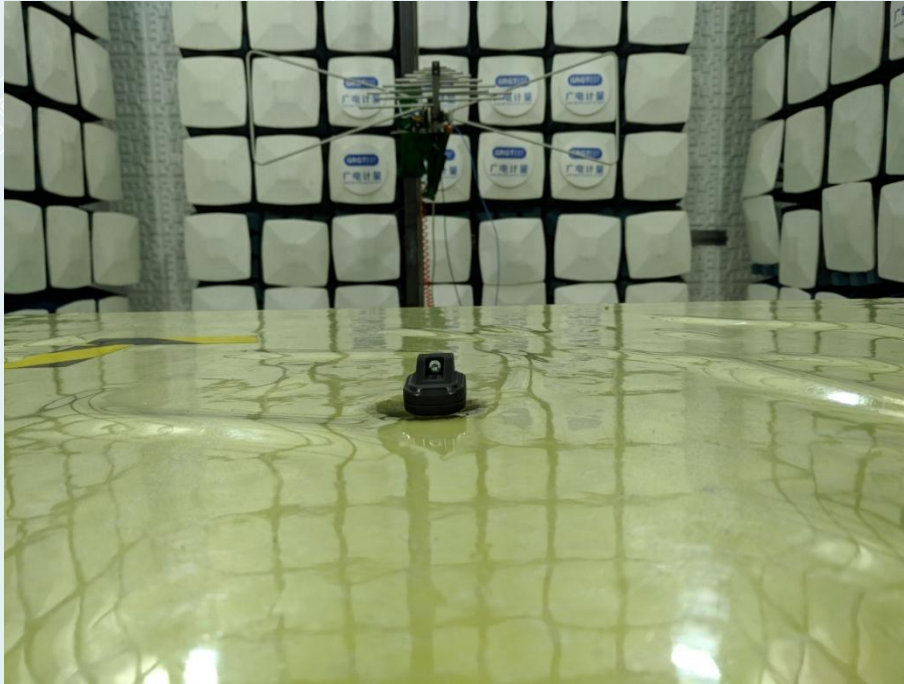

RSE (Above 1GHz)



-----This is the last page of the report.-----