

tineco

FLOOR ONE S7 COMBO SERIES

Smart Cordless Floor Washer

Instruction Manual

Manual De Uso

Mode D'emploi



*Actual product may differ from illustration.

TINECO IS HERE TO HELP.

We'll get back to you within 1 business day.



 www.tineco.com

 1-855-292-8864

CONTENTS

Important Safety Instructions.....	2
Specifications	6
Overview.....	7
Accessories.....	9
Assembly	10
Operation.....	12
Maintenance	18
Troubleshooting.....	24
Warranty	25

TINECO IS HERE TO HELP.
 We'll get back to you within 1 business day.

 www.tineco.com
 1-855-292-8864

Important Safety Instructions

SAVE THESE INSTRUCTIONS Household use only.

When using an electrical appliance, basic precautions should always be followed, including the following:

READ ALL INSTRUCTIONS BEFORE USING (THIS APPLIANCE). Failure to follow the warnings and instructions may result in electric shock, fire and/or serious injury.

WARNING – To reduce the risk of fire, electric shock, or injury:

1. This appliance can be used by children aged from 8 years and above and persons with reduced physical, sensory or mental capabilities or lack of experience and knowledge if they have been given supervision or instruction concerning use of the appliance in a safe way and understand the hazards involved. Children should not play with the appliance. Cleaning and user maintenance shall not be performed by children without supervision.
2. The appliance is not to be used by persons (including children) with reduced physical, sensory or mental capabilities, or lack of experience and knowledge, unless they have been given supervision or instruction.
3. Use only indoors, on non-carpeted floor surfaces such as vinyl, tile, sealed wood, etc. Be careful not to run over loose objects or edges of area rugs. Stalling the brush may result in premature belt failure.
4. Do not allow to be used as a toy. Close attention is necessary when used by or near children, pets or plants.
5. Use only as described in this manual. Use only manufacturer's recommended attachments.
6. Do not use with a damaged cord or plug. If appliance has been dropped, damaged, left outdoors, dropped into water, or is not working as it should, return it to a service center.
7. Do not handle charger, including charger plug, and charger terminals with wet hands.
8. Do not put any object into openings. Do not use with any opening blocked; keep free of dust, lint, hair, and anything that may reduce air flow.
9. Keep hair, loose clothing, fingers, and all parts of your body away from openings and moving parts.
10. Use extra care when cleaning on stairs.
11. Do not use to pick up flammable or combustible liquids, such as gasoline, or use in areas where they may be present.
12. Do not pick up anything that is burning or smoking, such as cigarettes, matches, or hot ashes.
13. Do not use without filter.
14. Prevent unintentional activation. Ensure the switch is in the off-position before picking up or carrying the appliance. Carrying the appliance with your finger on the switch or energizing appliance that have the switch on invites accidents.
15. Always switch off the appliance before making any adjustments, changing accessories, or storing the appliance. Such preventive safety measures reduce the risk of starting the appliance accidentally.

16. Recharge only with the charger specified by Tineco. A charger that is suitable for one type of battery pack may create a risk of fire when used with another battery pack.
17. Use appliances only with specifically designated Tineco battery packs. Use of any other battery packs may create a risk of injury and fire.
18. Under abusive conditions, liquid may be ejected from the battery; avoid contact. If contact accidentally occurs, flush with water. If liquid comes into eye contact, seek medical help. Liquid ejected from the battery may cause irritation or burns.
19. Do not use a battery pack or appliance that is damaged or modified. Damaged or modified batteries may exhibit unpredictable behavior resulting in fire, explosion or risk of injury.
20. Do not expose a battery pack or appliance to fire or excessive temperature. Exposure to fire or temperature above 266°F (130°C) may cause an explosion.
21. Follow all charging instructions and do not charge the battery pack or appliance outside of the temperature range specified in the instructions. Charging improperly or at temperatures outside of the specified range may damage the battery and increase the risk of fire.
22. Have servicing performed by a qualified repair person using only identical replacement parts. This will ensure that the safety of the product is maintained.
23. This appliance contains battery cells that are non-replaceable. Do not modify or attempt to repair the appliance or the battery pack except as indicated in the instructions for use and care.
24. Always turn off this appliance before connecting or disconnecting the motorized nozzle.
25. Do not charge or store the appliance outdoors or inside the car. Only charge, store or use the battery in a dry indoor area where the temperature is higher than 39.2°F (4°C) but lower than 104°F (40°C). The charger is for indoor use only.
26. Do not use to pick up ultrafine particles, such as lime, cement, sawdust, gypsum powder, or ashes.
27. Do not use to pick up sharp objects, such as metallic nails, pieces of glass, metal paper clips, or pins.
28. Do not use to pick up hazardous material and chemicals, such as solvent, drain cleaner, strong acids, or strong alkali.
29. Stop using immediately if the appliance is overheating, making unusual noises, producing unusual odors, performing low suction, or leaks electricity.
30. Turn cleaner OFF and disconnect from electrical outlet for long-term storage.
31. Always clean the Dirty Water Tank after each use to avoid potential blockage, which may lead to low suction power, motor overheating, or reduce the service life of the appliance.
32. Store appropriately indoors in a dry place after use.
33. Do not place or submerge appliance in standing water or try to clean flooded areas.
34. All data and technical instructions of this manual are based on results from lab tests of Tineco or designated third parties. The company reserves all rights for final explanations.
35. The plug must be removed from the socket-outlet before cleaning or maintaining the appliance.
36. A hazard may occur if the appliance runs over the supply cord.
37. Do not use the appliance when the water depth is more than 5mm above the surface.

38. Do not unplug by pulling on cord. To unplug, grasp the plug, not the cord.
39. When battery pack is not in use, keep it away from metal objects such as paper clips, coins, keys, nails, screws or other small metal objects that could create a connection between the battery terminals. Short-circuiting the battery terminals may result in burns or a fire.

Range of Usage

1. The cordless hard floor cleaner is to be used on indoor hard floors, such as vinyl, tile, sealed wood, etc. Use on a rough surface may not get the best performance.
2. Keep your appliance away from heat sources, such as fireplace or heater, to avoid casing deformation.
3. Do not use to pick up flammable or combustible liquids, ultrafine particles, sharp objects, hazardous material, chemicals or anything that is burning or smoking, as described above.

About Cleaning Solution

1. **WARNING** – To Reduce the Risk of Fire and Electric Shock – Use only Tineco cleaning solution designed for use with this machine.
2. A large amount of cleaning solution entering into the motor may cause damage to the appliance.
3. Add solution as instructed in the Operation section. We recommend using the provided cleaning solution. Do not use the product with acidic, alkaline solution, or any substances harmful to the environment.
4. Keep out of the reach of children. Avoid contact with eyes and skin, otherwise, rinse thoroughly with water. If irritation persists, seek medical advice. If product is swallowed seek medical advice.
5. Dirty water and solution disposal should comply with local environmental regulations.

About the Appliance

1. Do not modify or attempt to repair the appliance except as indicated in the instructions for operating and cleaning.
2. Charge the appliance with the Tineco adaptor. Input Voltage: AC 100-240V. Both high and low voltages can damage the adaptor, appliance, or even cause danger to the user.
3. Use extra care when cleaning on stairs.
4. Ensure that the Power Switch is in the OFF-position before picking up or carrying the appliance. Do not lay flat or lean the appliance so as to prevent dirty water from entering into the motor.
5. To avoid being tripped accidentally, please put away the appliance on the charging base.
6. Always install the Dirty Water Tank and Clean Water Tank properly before use.
7. Do not allow the appliance or charger to get wet to avoid risk of fire or injury caused by a short circuit.

FCC Supplier's Declaration of Conformity

TINECO / FLOOR ONE S7 COMBO SERIES

This appliance complies with part 15 of the FCC Rules. Operation is subject to the following two conditions:

(1) This appliance may not cause harmful interference, and (2) this appliance must accept any interference received, including interference that may cause undesired operation.

TINECO INTELLIGENT, INC.

1700 WESTLAKE AVENUE N., SUITE 200, SEATTLE, WA, 98109, USA

WWW.TINECO.COM

1-855-292-8864

Changes or modifications not expressly approved by the party responsible for compliance could void the user's authority to operate the equipment.

Note: This equipment has been tested and found to comply with the limits for a Class B digital appliance, pursuant to Part 15 of the FCC Rules. These limits are designed to provide reasonable protection against harmful interference in a residential installation.

This equipment generates uses and can radiate radio frequency energy and, if not installed and used in accordance with the instructions, may cause harmful interference to radio communications. However, there is no guarantee that interference will not occur in a particular installation. If this equipment does cause harmful interference to radio or television reception, which can be determined by turning the equipment off and on, the user is encouraged to try to correct the interference by one or more of the following measures:

- (1) Reorient or relocate the receiving antenna.
- (2) Increase the separation between the equipment and receiver.
- (3) Connect the equipment into an outlet on a circuit different from that to which the receiver is connected.
- (4) Consult the dealer or an experienced radio/TV technician for help.

FCC Radiation Exposure Statement

This equipment complies with FCC radiation exposure limits set forth for an uncontrolled environment. This equipment should be installed and operated with a minimum distance of 20cm between the radiator and any part of your body.

Note

The manufacturer is not responsible for any radio or TV interference caused by unauthorized modifications to this equipment, such modifications could void the user's authority to operate this equipment.



IC Note

This appliance contains licence-exempt transmitter(s)/receiver(s) that comply with Innovation, Science and Economic Development Canada's licence-exempt RSS(s). Operation is subject to the following two conditions:

- (1) This appliance may not cause interference.
 - (2) This appliance must accept any interference, including interference that may cause undesired operation of the appliance.
- This Class B digital apparatus complies with Canadian ICES-003.
 - This equipment complies with ISED RSS-102 radiation exposure limits set forth for an uncontrolled environment. This equipment should be installed and operated with a minimum distance of 20cm between the radiator and any part of your body.

Specifications

Product	FLOOR ONE S7 COMBO SERIES
AC Input	100-240V~
Voltage	25.2V \equiv 3900mAh Lion
Rated Power	250W
Running Time	Floor Washer: 28~40 mins/Vacuum Cleaner: 25~65 mins
Charging Time	4~5 hrs
Water Flow Rate	20~100ml/min
CWT Capacity	~0.85L
DWT Capacity	~0.72L
Waterproof	IPX4

Disposal

- The battery contains materials that are harmful to the environment and must be removed from the appliance before it is discarded.
- When removing the battery, the appliance must be powered off.
- Batteries, chargers, accessories and packaging should be sorted out for environmental friendly recycling. Do not put them into fire, water or soil. Do not dispose of batteries and chargers into household waste! 
- If battery leakage contacts skin or clothing, immediately flush with water to avoid irritation and seek medical help.

Overview

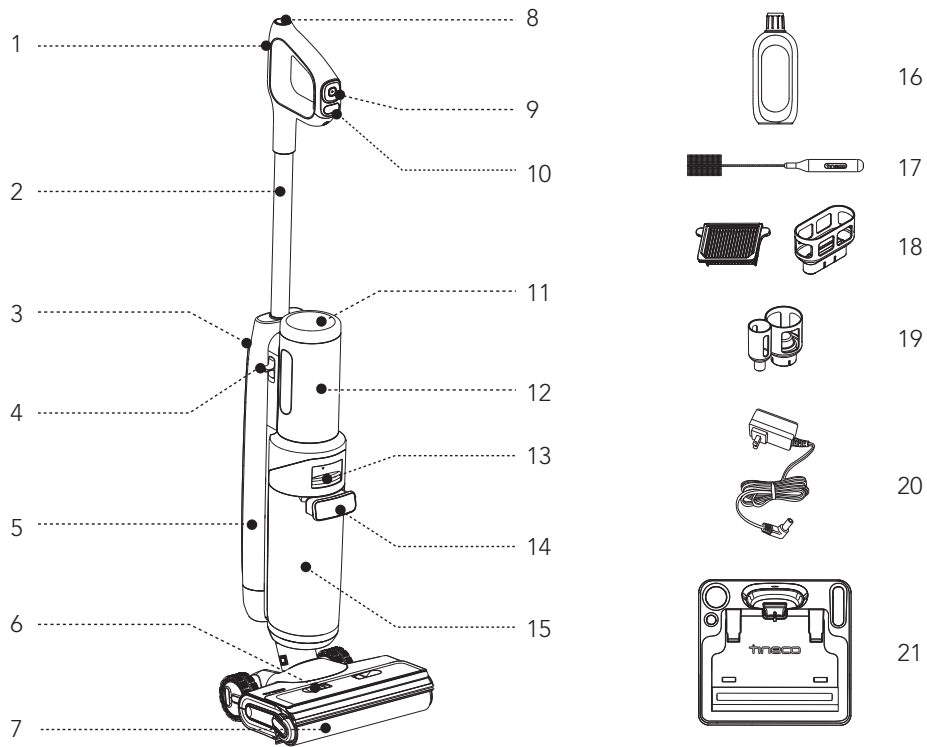

- | | |
|-------------------------------------|-------------------------------------|
| 1. WiFi/Mute/Language Switch Button | 12. Power Source |
| 2. Tube | 13. Dirty Water Tank Release |
| 3. Tube Release | 14. Dirty Water Tank Handle |
| 4. Power Source Release | 15. Dirty Water Tank (DWT) |
| 5. Clean Water Tank (CWT) | 16. Deodorizing & Cleaning Solution |
| 6. Brush Roller Cover | 17. Cleaning Tool |
| 7. Brush Roller | 18. Dry Filter & Holder |
| 8. Self-cleaning Button | 19. Accessory Holder |
| 9. Menu Button | 20. Adaptor |
| 10. Power On/Off | 21. Charging Dock |
| 11. Digital Display | |

EN

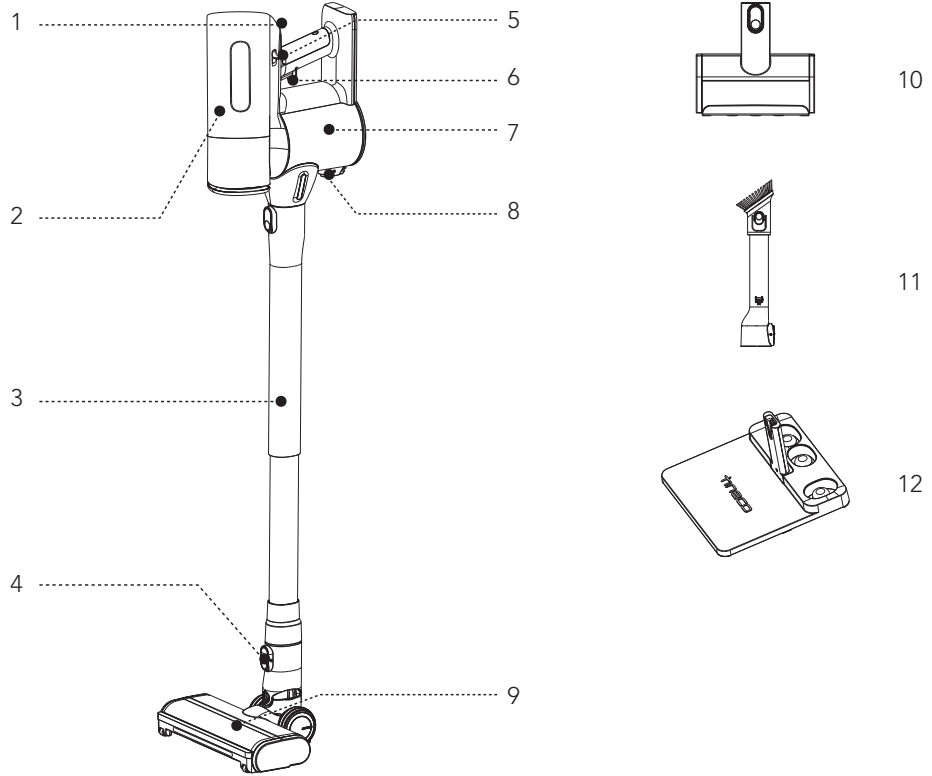

- 1. AUTO/MAX Mode
- 2. Multi-cone Assembly Removal Tool
- 3. Tube
- 4. Release Button
- 5. Multi-cone Assembly Release
- 6. Power On/Off

- 7. Dustbin
- 8. Dustbin Empty Release
- 9. Anti-tangle Power Brush
- 10. Mini Power Brush
- 11. 2-in-1 Dusting Brush Crevice Tool
- 12. Vacuum Dock

Accessories

Note:

Accessories may vary among markets. If you require more accessories, please go to www.tineco.com or store.tineco.com.

NE



Deodorizing & Cleaning Solution

Removes dirt, grime, grease and tough stains from most types of hard surfaces, like tile, marble, sealed hardwood floors, and more. Always use Tineco solution in your appliance. Add one bottle cap of solution to each full tank of clean water.



Brush Roller

Soft roller head with bristles can be used to vacuum and wash at the same time. It can be easily cleaned with the self-cleaning function.



Dry Filter

Dry filter and filter net can block large particles and debris, ensuring the appliance's durability.

* Please install the dry filter before use, or it may lead to weak suction.



Cleaning Tool

A full brush to clean the DWT, brush chamber and opening. The tool also has a bristled end to remove dirt and mud on the roller and DWT.

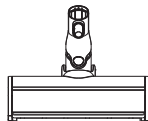

Anti-tangle Power Brush

Ideal for both hard floors and carpets. Picks up ground-in dirt with no hair wrap.

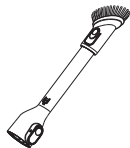

2-in-1 Dusting Brush Crevice Tool

The slimline crevice tool is ideal for tight spots, corners and crevices, while the brush is ideal for cleaning above the floor surfaces.

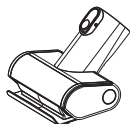

Mini Power Brush

For vacuuming upholstered furniture, mattresses etc. Vacuums pet hair and removes ingrained dirt.

Assembly

How to Assemble/Disassemble Floor Washer

Note: For water tank and brush assembly, please refer to "Operation" and "Maintenance".

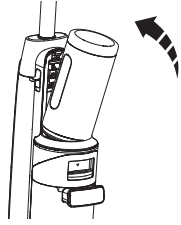

To install, insert the power source into the floor washer, push it in, installation is complete when you hear a click.

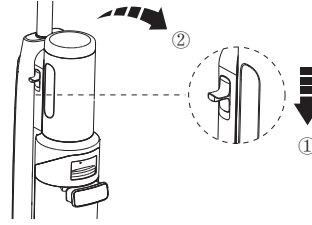

To remove the power source, hold the appliance with one hand and press the release slider with the other hand.

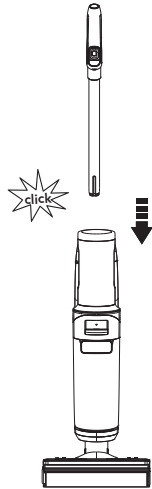

To assemble the handle, insert it into the appliance until you hear a click.

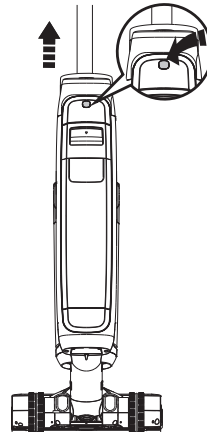

To remove the handle, press the release button on the back of the appliance, then pull the handle upwards.

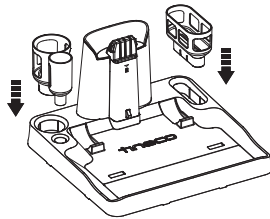

Place the dry filter holder and accessory holder on the dock.

Vacuum Cleaner

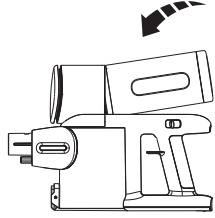

To install, insert the power source into the vacuum cleaner, push it in, installation is complete when you hear a click.

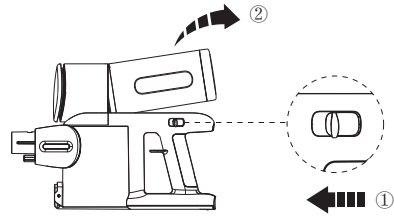

To remove the power source, hold the appliance with one hand and press the release slider with the other hand.

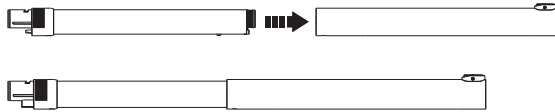

Connect the tube.

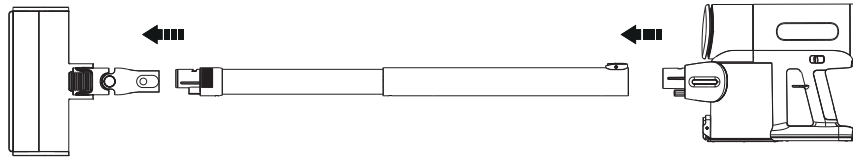

Connect the brush, tube and main body as shown above.

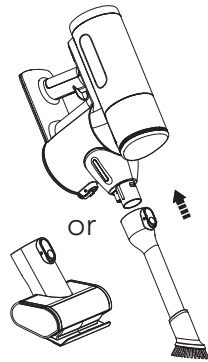

Connect the accessory tool to the main body.

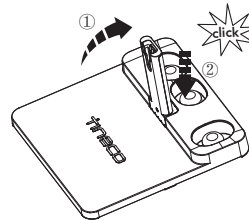

Lift up the post, press it hard to fix the post firmly on the dock.

Operation

Preparing for Use

Floor Washer

- Before first use, please charge the appliance for 4-5 hours (refer to “Charging Instructions” for details).
 - * Based on results from Tineco lab tests. Lab temperature 39.2°F (4°C) ~ 104°F (40°C).
- For the first use, the appliance will display the Quick Start Guide and Interactive Tutorial, press the Self-cleaning button to exit.



Quick Start Guide

Brief introduction to the buttons and how to use the appliance.



Interactive Tutorial

Tutorial for the interactive operations, including Fill Up the Clean Water Tank, Start Cleaning, Pause Cleaning and Clean the Dirty Water Tank.

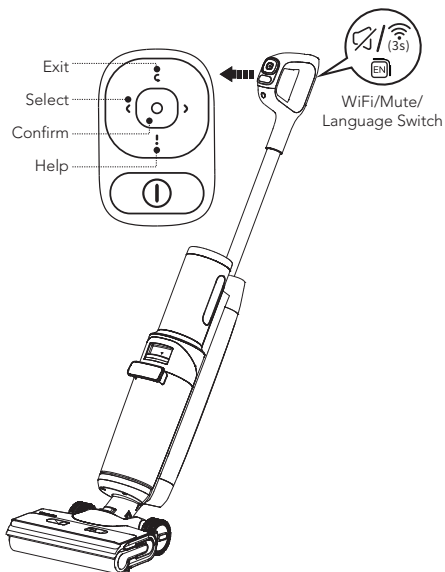



Menu Button

- ◀ Exit: Press to exit the current interface.
- ↔ Select: During cleaning, press the left or right button to switch between different modes.
- Confirm: Press to enter a certain mode when switching.
- ! Help: Press to enter Tineco Assistant which contains Quick Start Guide, Maintenance, WiFi Connection, Handle Disassembly and Customer Service.

WiFi/Mute/Language Switch Button

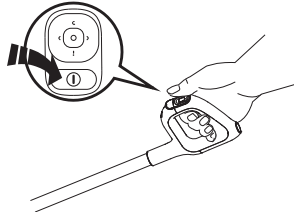
- Press to turn on/off the voice prompt.
- Press twice to switch languages. (More voice languages will be added, please refer to the actual product for now.)
- Hold for 3 seconds to connect to network.



Press the  button and the appliance will start in AUTO mode by default, press the Select button to switch between different modes.

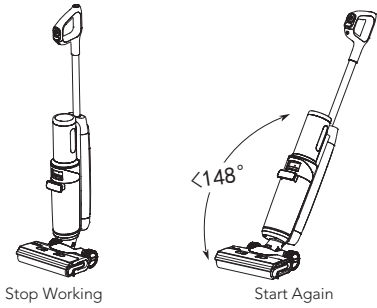

The appliance will stop working when put upright and start running again when reclined.
 * Do not recline more than 148° to avoid water leakage.

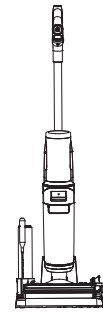



Place the appliance on the charging dock vertically after use for recharge and storage.

Note:

- Selecting the appropriate mode depending on the CWT contents is vital for maximum dirt detection effectiveness.
- Do not vacuum foamed liquid.
- To vacuum water left on the surface, the appliance will keep running for 3 seconds after power off.

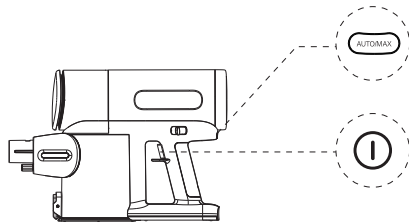
Vacuum Cleaner



Press the  button and the appliance will start in AUTO mode by default. Press it again to turn off the appliance. Switch between AUTO and MAX mode by pressing the  button.

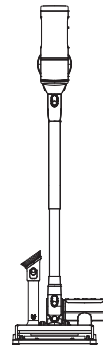

Place the appliance and attachments on the vacuum dock for convenient storage after use.

Filling Clean Water Tank

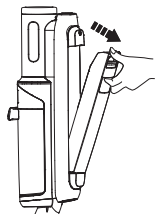

Press the Clean Water Tank release button to remove CWT from the appliance.

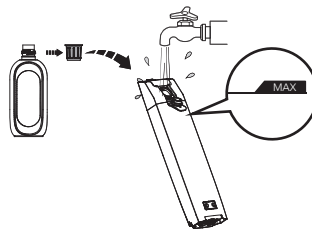

Open the tank cap, and fill the tank with tap water to the Max line. When deep cleaning is necessary, add one bottle cap of solution to the CWT and tightly close the cap.

Note:

**Only use water under 140°F/60°C.
DO NOT USE HOT WATER.**

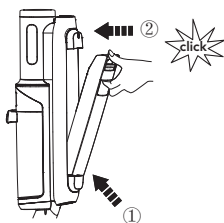

Place the tank back into the appliance. You should hear a "click" if done correctly.

Charging Instructions

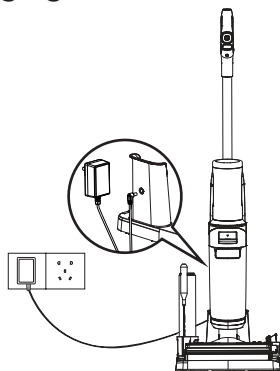

To charge the appliance, place the appliance on the charging dock and plug the adaptor into a power outlet.

1. To charge the appliance, connect the external charging cord to the charging dock and plug it into the wall outlet.
2. To avoid tripping hazards, please place the appliance on the charging dock near a wall during charging.



Warning:

- Only charge the appliance with the adaptor supplied by Tineco.
- During long periods of not being used, the appliance must be charged once every 3 months for optimal performance. It may take 4-5 hours for a full charge.
- Store indoors in a dry place. Do not expose the appliance to sunlight or freezing temperatures. Recommended temperature range: 39.2°F (4°C) ~ 104°F (40°C).

Digital Display

An updated display shows everything with interactive animation, giving you a brand new experience during and after cleaning.

Note:

Keep sharp objects away from the digital display screen to avoid scratches and scrapes.

Cleaning Mode Selection

Floor Washer

AUTO Mode



- In AUTO mode, the iLoop sensor automatically detects how dirty the floor is and applies the appropriate amount of detergent and suction power.
- A red dirt monitoring loop indicates more dirt is detected, and a blue loop indicates less dirt is detected. This mode automatically provides the best cleaning solution.

MAX Mode



- Press the left or right Select button to enter MAX mode.
- In MAX mode, the appliance will apply max suction power and will spray water/solution for embedded stains.

ULTRA Mode



- Press the left or right Select button to enter ULTRA mode.
- In ULTRA mode, the appliance will prepare for 30 seconds and then start to working. This mode is suitable for deep cleaning.

SUCTION Mode



- Press the left or right Select button to enter SUCTION mode.
- In SUCTION mode, the appliance will absorb water. We recommend using this mode on wet surfaces.

EN

Vacuum Cleaner

AUTO Mode



- When the main body is used as a vacuum cleaner, the appliance will start in AUTO mode by default.

MAX Mode



- Press the left or right Select button to enter MAX mode.
- In MAX mode, the appliance will apply max suction power to remove stubborn stains.

App

All the functions can be performed using the Tineco app. Download the Tineco app from App Store, Google Play and Tineco Official Site.

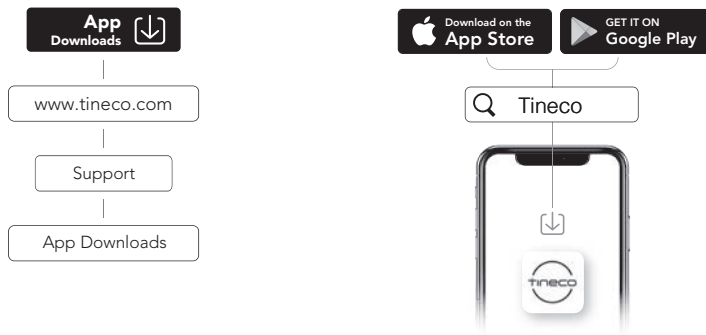

Note:

The default language for voice prompt is English, you can set other languages via App.

Voice Prompt (Contents may vary, please in kind prevail.)

Status	Reminder
Before first use	Hi, welcome to Tineco Assistant. Let's begin the Quick Start Guide.
Voice prompts on	Voice prompts on.
Voice prompts off	Voice prompts off.
Connect the Tineco app	Scan QR code to download app and connect appliance.
Auto mode by default	Auto mode.
Switch to Suction mode	Suction mode.
Switch to Max mode	Max mode.
Switch to Ultra mode	Ultra mode.
Battery level: 10~20%	Low power.
Battery level: 0~10%	Low power. Please charge the appliance.
Clean Water Tank is empty	Insufficient water in the Clean Water Tank. Please fill up water.
Need self cleaning	To optimize cleaning performance, please perform self-clean cycle.
Can not perform self-cleaning	Please place appliance on the charging dock to begin self-cleaning.
Dirty Water Tank is full	Dirty Water Tank full. Please empty.
Prepare the solution in Ultra mode	Solution is ready. Please start cleaning.
Brush roller is tangled	Please clean the brush roller.
Power off	Powering off.
Battery insufficient for self-cleaning	Low power. Please charge before initiating self-cleaning.
Cleaning the brush roller	Cleaning the brush roller.
Cleaning the pipe	Cleaning the pipe.
Drying the Brush Roller	Drying the Brush Roller.
Deep cleaning	Deep cleaning.
Self-cleaning complete	Self-cleaning complete. Please empty and clean the Dirty Water Tank to prevent odors.
Start charging	Charging.
Insufficient water for self-cleaning	Please fill water and start self-cleaning.

Maintenance

Note:

- For optimal performance and to prevent odors, always **clean** and **dry** DWT, filters, brush roller, brush roller cover **completely** after each use.
- Please make sure each part is installed correctly or the appliance may not work properly.
- Do not soak the appliance or wash it under water.
- Some water may remain in the appliance due to factory inspection.
- After maintenance, place the appliance on the charging dock vertically. Do not expose the appliance to direct sunlight, and store it indoors in a dry place.

Main Body

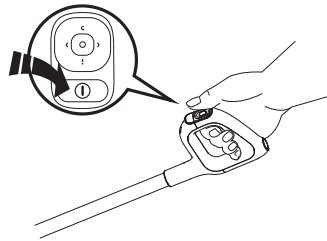

To reduce the risk of injury, switch off before performing maintenance.

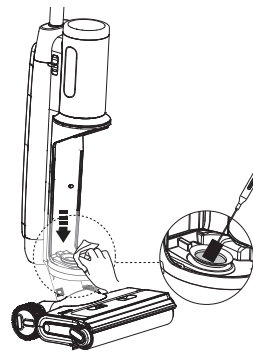

Clean the dirt sensor with a damp cloth or the cleaning tool.

Dirty Water Tank

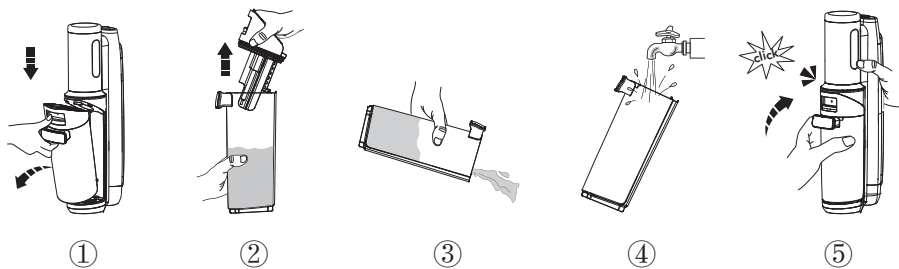

- When dirty water reaches the Max line, the appliance will stop working and show a reminder on the display and play a voice prompt.
- Pull up the tank lid to empty the DWT. Use the cleaning tool to remove remaining debris. Rinse the inside of the DWT and place back into the appliance.

Dry Filter

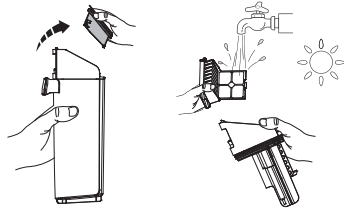

Grasp recessed area on each side of the dry filter and pull upward. Rinse under running water and must be completely dry before recombining with the lid of the DWT.
 *A spare dry filter is provided with your appliance for convenient replacement.

Brush Roller Self-cleaning

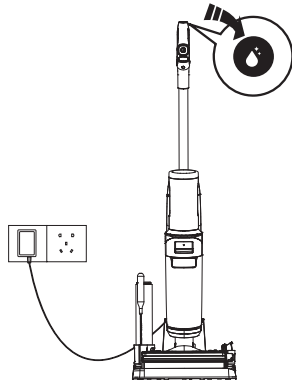

1. Place the appliance on the charging dock after use, the sensor will auto-detect the level of dirt.
2. Press the self-cleaning button and you can select the Quick Self-cleaning (takes 3 minutes) or Super Self-cleaning (takes 6 minutes) to begin the process.
3. Once complete, please clean the Dirty Water Tank. And the appliance will begin charging.

Note:

- Ensure the charging dock is plugged in and the battery level > 20%.
- Before self-cleaning cycle, please clean the DWT and ensure the water level in the CWT > 40%.

Brush Roller Cover

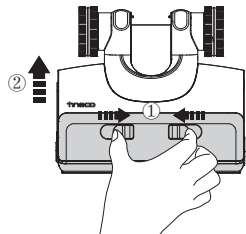

Squeeze latches on the cover and pull upward to remove.

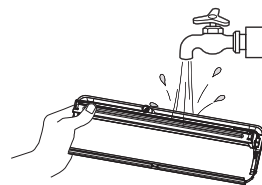

Rinse with water.

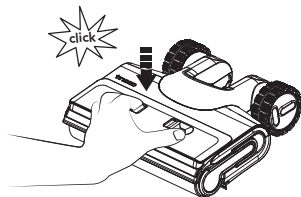

While replacing, always latch the brush cover into place to avoid leakage.