

# tineco

## CARPET ONE

Smart Carpet Washer

Instruction Manual

Manual De Uso

Mode D'emploi



\*Actual product may differ from illustration.

**TINECO IS HERE TO HELP.**

We'll get back to you within 1 business day.



 [www.tineco.com](http://www.tineco.com)

 **1-855-292-8864**  
Mon. - Fri. 9am - 6pm (CST)



# CONTENTS

Important Safety Instructions.....	2
Overview.....	7
Accessories.....	9
Assembly.....	10
Operation.....	13
Maintenance.....	21
Specifications.....	26
Troubleshooting.....	27
Warranty.....	28

**TINECO IS HERE TO HELP.**

We'll get back to you within 1 business day.

 [www.tineco.com](http://www.tineco.com)



**1-855-292-8864**

Mon. - Fri. 9am - 6pm (CST)

# Important Safety Instructions

## SAVE THESE INSTRUCTIONS

### Household use only.

When using an electrical appliance, basic precautions should always be followed, including the following:

READ ALL INSTRUCTIONS BEFORE USING (THIS APPLIANCE). Failure to follow the warnings and instructions may result in electric shock, fire and/or serious injury.

## WARNING – To reduce the risk of fire, electric shock, or injury:

1. This appliance can be used by children aged from 8 years and above and persons with reduced physical, sensory or mental capabilities or lack of experience and knowledge if they have been given supervision or instruction concerning use of the appliance in a safe way and understand the hazards involved. Children should not play with the appliance. Cleaning and user maintenance shall not be performed by children without supervision.
2. The appliance is not to be used by persons (including children) with reduced physical, sensory or mental capabilities, or lack of experience and knowledge, unless they have been given supervision or instruction.
3. Use only indoors, do not immerse. To reduce risk of electric shock – Use only on carpet moistened by cleaning process.
4. Do not allow to be used as a toy. Close attention is necessary when used by or near children, pets or plants.
5. To reduce the risk of fire and electric shock – Use only Tineco cleaning products intended for use with this machine.
6. Use only as described in this manual. Use only manufacturer's recommended attachments.
7. Do not pull or carry by cord, use cord as a handle, close a door on cord, or pull cord around sharp edges or corners. Do not run appliance over cord. Keep cord away from heated surfaces.
8. Do not unplug by pulling on cord. To unplug, grasp the plug, not the cord.
9. Do not handle plug or appliance with wet hands.
10. Do not use with a damaged cord or plug. If appliance has been dropped, damaged, left outdoors, dropped into water, or is not working as it should, return it to a service center.
11. Do not put any object into openings. Do not use with any opening blocked; keep free of dust, lint, hair, and anything that may reduce air flow.
12. Keep hair, loose clothing, fingers, and all parts of your body away from openings and moving parts.
13. Use extra care when cleaning on stairs.
14. Do not use to pick up flammable or combustible liquids, such as gasoline, or use in areas where they may be present.
15. Do not pick up anything that is burning or smoking, such as cigarettes, matches, or hot ashes.

16. Do not use without filter.
17. To reduce the risk of electric shock, always install float before any wet pick-up operation.
18. Prevent unintentional activation. Ensure the switch is in the off-position before picking up or carrying the appliance. Carrying the appliance with your finger on the switch or energizing appliance that have the switch on invites accidents.
19. Always switch off the appliance before making any adjustments, changing accessories, or storing the appliance. Such preventive safety measures reduce the risk of starting the appliance accidentally.
20. TO REDUCE THE RISK OF ELECTRIC SHOCK – UNPLUG BEFORE CLEANING OR SERVICING. UNPLUG BEFORE CONNECTING HOSE.
21. Always turn off this appliance before connecting or disconnecting the motorized nozzle.
22. Turn off all controls before unplugging.
23. Do not leave appliance when plugged in. Unplug from outlet when not in use and before servicing.
24. Do not use to pick up ultrafine particles, such as lime, cement, sawdust, gypsum powder, or ashes.
25. Do not use to pick up sharp objects, such as metallic nails, pieces of glass, metal paper clips, or pins.
26. Do not use to pick up hazardous material and chemicals, such as solvent, drain cleaner, strong acids, or strong alkali.
27. Stop using immediately if the appliance is overheating, making unusual noises, producing unusual odors, performing low suction, or leaking electricity.
28. Turn cleaner OFF and disconnect from electrical outlet for long-term storage.
29. Always clean the Dirty Water Tank after each use to avoid potential blockage, which may lead to low suction power, motor overheating, or reduce the service life of the appliance.
30. Do not expose to rain.
31. Store appropriately indoors in a dry place after use.
32. Do not place or submerge appliance in standing water or try to clean flooded areas.
33. The plug must be removed from the socket-outlet before cleaning or maintaining the appliance.
34. A hazard may occur if the appliance runs over the supply cord.
35. Connect to a properly grounded outlet only. See Grounding Instructions.
36. To reduce the risk of fire and electric shock due to internal component damage, use only Tineco cleaning fluid/solution: Carpet Deodorizing & Cleaning Solution intended for use with this appliance. See the Cleaning Fluid/Solution section of this manual.
37. Do not turn over nozzle, or touch the bottom surface of the nozzle when using the dry function.

## Range of Usage

1. The Carpet washer is to be used on carpets, such as level loop, etc.
2. Keep your appliance away from heat sources, such as fireplace or heater, to avoid casing deformation.
3. Do not use to pick up flammable or combustible liquids, ultrafine particles, sharp objects, hazardous material, chemicals or anything that is burning or smoking, as described above.

## About Cleaning Fluid/Solution

1. A large amount of cleaning solution entering into the motor may cause damage to the appliance. Don't shake the machine violently.
2. Add solution as instructed in the Operation section. We recommend using the provided cleaning solution.
3. Keep out of reach of children. If any solution gets into the eyes, immediately flush them with clean water. If any solution is swallowed by accident, seek medical care immediately.
4. Dirty water and solution disposal should comply with local environmental regulations.
5. **WARNING:** To Reduce the Risk of Fire and Electric Shock due to internal component damage, use only TINECO CARPET DEODORIZING & CLEANING SOLUTION intended for use with the appliance.

## About the Appliance

1. Do not modify or attempt to repair the appliance except as indicated in the instructions for operating and cleaning.
2. Use extra care when cleaning on stairs.
3. Ensure that the Power Switch is in the OFF-position and unplug before picking up or carrying the appliance. Do not lay flat or lean the appliance so as to prevent dirty water from entering into the motor.
4. Always install the Dirty Water Tank and Clean Water Tank properly before use.
5. Do not allow the appliance to get wet to avoid risk of fire or injury caused by a short circuit.

## Grounding Instructions

1. This appliance must be grounded. If it should malfunction or breakdown, grounding provides a path of least resistance for electric current to reduce the risk of electric shock. This appliance is equipped with a cord having an equipment-grounding conductor and grounding plug. The plug must be inserted into an appropriate outlet that is properly installed and grounded in accordance with all local codes and ordinances.
2. **WARNING** – Improper connection of the equipment-grounding conductor can result in a risk of electric shock. Check with a qualified electrician or service person if you are in doubt as to whether the outlet is properly grounded. Do not modify the plug provided with the appliance – if it will not fit the outlet, have a proper outlet installed by a qualified electrician.

3. This appliance is for use on a nominal 120-V circuit and has a grounding attachment plug that looks like the plug illustrated in sketch A in Figure 20. Make sure that the appliance is connected to an outlet having the same configuration as the plug. No adaptor should be used with this appliance.

## FCC Supplier's Declaration of Conformity

TINECO / CARPET ONE SERIES

This appliance complies with part 15 of the FCC Rules. Operation is subject to the following two conditions:

- (1) This appliance may not cause harmful interference, and (2) this appliance must accept any interference received, including interference that may cause undesired operation.

TINECO INTELLIGENT, INC.

1700 WESTLAKE AVENUE N., SUITE 200, SEATTLE, WA, 98109, USA

WWW.TINECO.COM

1-855-292-8864

Changes or modifications not expressly approved by the party responsible for compliance could void the user's authority to operate the equipment.

Note: This equipment has been tested and found to comply with the limits for a Class B digital appliance, pursuant to Part 15 of the FCC Rules. These limits are designed to provide reasonable protection against harmful interference in a residential installation.

This equipment generates uses and can radiate radio frequency energy and, if not installed and used in accordance with the instructions, may cause harmful interference to radio communications. However, there is no guarantee that interference will not occur in a particular installation. If this equipment does cause harmful interference to radio or television reception, which can be determined by turning the equipment off and on, the user is encouraged to try to correct the interference by one or more of the following measures:

- (1) Reorient or relocate the receiving antenna.
- (2) Increase the separation between the equipment and receiver.
- (3) Connect the equipment into an outlet on a circuit different from that to which the receiver is connected.
- (4) Consult the dealer or an experienced radio/TV technician for help.

## FCC Radiation Exposure Statement

This equipment complies with FCC radiation exposure limits set forth for an uncontrolled environment. This equipment should be installed and operated with a minimum distance of 20cm between the radiator and any part of your body.

### Note

The manufacturer is not responsible for any radio or TV interference caused by unauthorized modifications to this equipment, such modifications could void the user's authority to operate this equipment.

# IC Note



This appliance contains licence-exempt transmitter(s)/receiver(s) that comply with Innovation, Science and Economic Development Canada's licence-exempt RSS(s).

Operation is subject to the following two conditions:

- (1) this appliance may not cause interference.
  - (2) this appliance must accept any interference, including interference that may cause undesired operation of the appliance.
- This Class B digital apparatus complies with Canadian ICES-003.
  - This equipment complies with ISED RSS-102 radiation exposure limits set forth for an uncontrolled environment. This equipment should be installed and operated with a minimum distance of 20cm between the radiator and any part of your body.

EN

## Symbols:

	Power On/Off
	AUTO/MAX Mode
	Dry Mode



# Overview

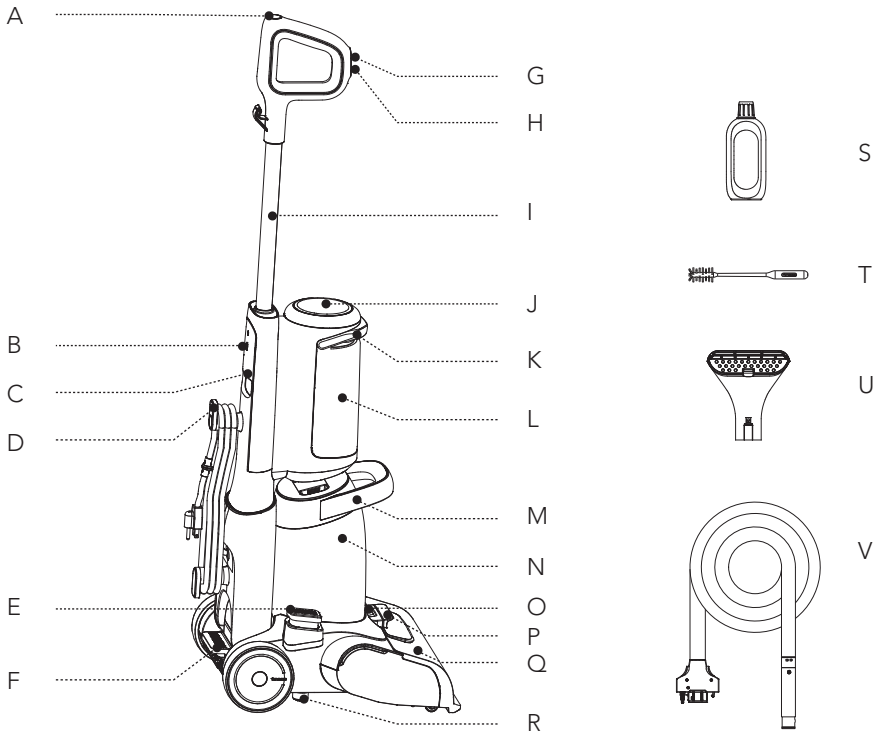

- A. Dry Mode
- B. WiFi/Mute Button
- C. Back Carry Handle
- D. Cord Wrap
- E. Dirty Water Tank Release Pedal
- F. Recline Pedal
- G. AUTO/MAX Mode
- H. Power On/Off
- I. Tube
- J. Digital Display
- K. Clean Water Tank Handle
- L. Clean Water Tank (CWT)
- M. Dirty Water Tank Handle
- N. Dirty Water Tank (DWT)
- O. Brush Roller Cover Release Button
- P. Hose Connection Port Cover
- Q. Brush Roller Cover
- R. Humidity Sensor
- S. Carpet Deodorizing & Cleaning Solution
- T. Cleaning Tool
- U. 2 in 1 Nozzle
- V. Accessory Hose

## Digital Display

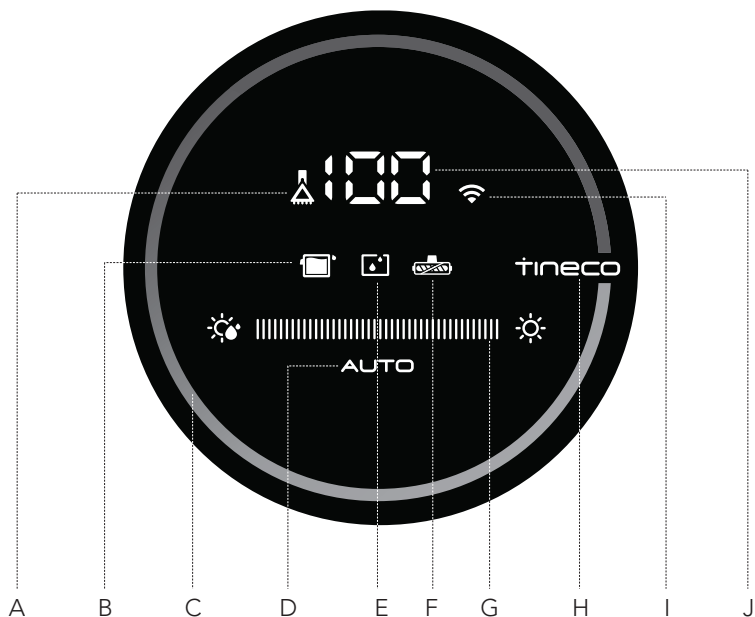

A. Accessory Hose Icon

B. DWT Full or Blocked

C. Dirt Monitoring Loop  
(Blue to red according to the dirt amount)

D. AUTO Mode

E. CWT Empty

F. Brush Roller Tangled Indicator

G. Dry Degree Indicator

H. Tineco Logo

I. WiFi Indicator

J. Water Spray Volume Indicator

# Accessories

## Note:

Accessories may vary between markets. If you require more accessories, please go to [www.tineco.com](http://www.tineco.com) or [store.tineco.com](http://store.tineco.com).

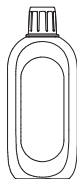

## Carpet Deodorizing & Cleaning Solution

Removes dirt, grime, grease and tough stains from most types of carpets.

Always use Tineco solution in your appliance.

Add two bottle caps of solution to each full tank of clean water.



## Cleaning Tool

A full brush to clean the DWT, brush chamber and opening.

The tool also has a bristled end to remove dirt and mud on the roller and DWT.

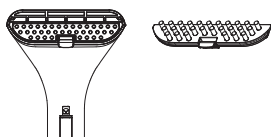

## 2 in 1 Nozzel

Remove tough stains on the carpet

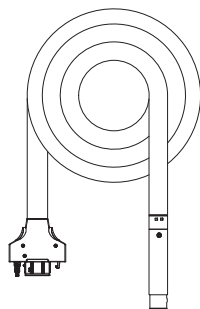

## Accessory Hose

A 2.5-meter hose to connect the appliance and accessory brushes.

# Assembly

## How to Assemble/Disassemble

Note:

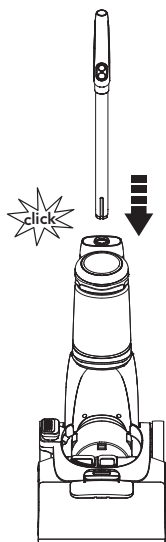

To assemble the handle, insert it into the appliance until you hear a click.

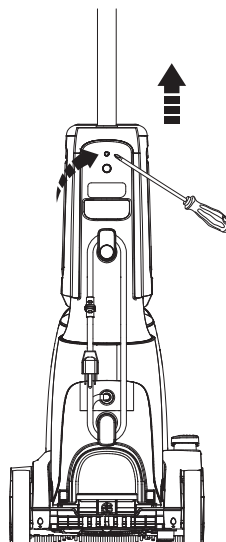

In the event that the product must be returned, please disassemble the handle. Press the spring to release the handle with a tool (like a screwdriver) and lift the released handle from the appliance.

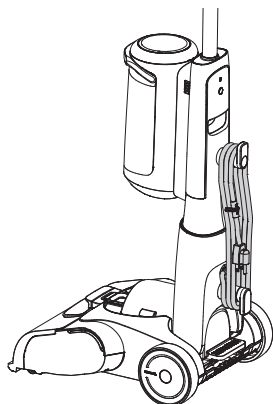

Wrap the power cord around the cord hooks for convenient storage.

## Clean Water Tank

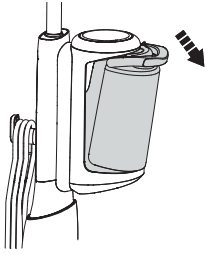

Press the CWT handle to remove it.

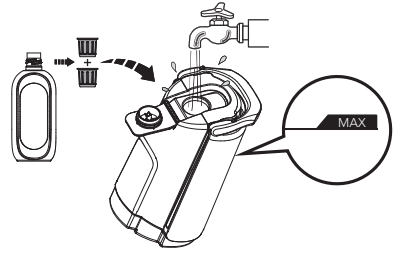

Open the tank cap, add two bottle caps of solution to the CWT then fill with tap water to the Max line and tightly close the cap.

### Note:

Only use water under 140°F/60°C.  
DO NOT USE HOT WATER.

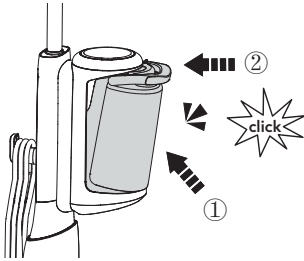

Install the Clean Water Tank into the appliance.  
You should hear a "Click" if done correctly.

## Dirty Water Tank

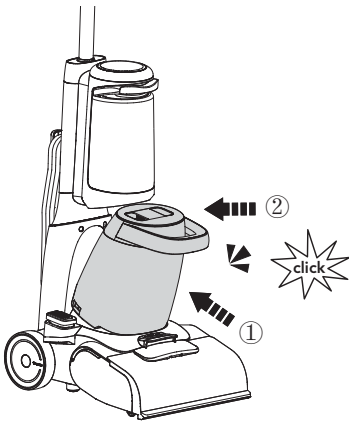

Install the Dirty Water Tank into the appliance.  
You should hear a "Click" if done correctly.

## Accessory Hose & 2 in 1 Nozzle

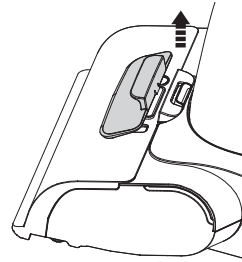
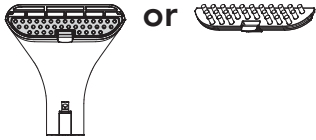

Choose suitable brush head according to the usage scenario.

Pull it up to uncover the accessory connection port.

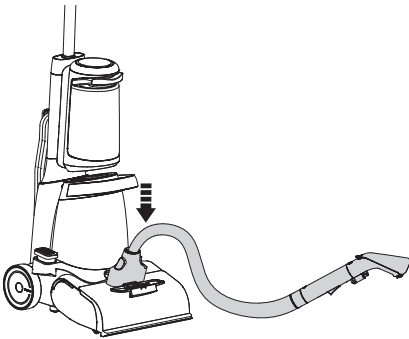

Insert the hose end into the port.  
You should hear two "Clicks" if done correctly.

# Operation

## Preparing for Use (Appliance)

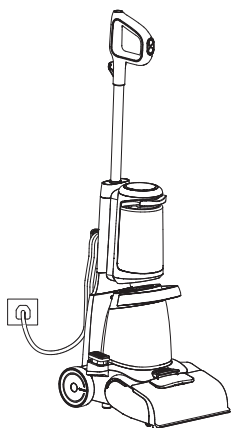

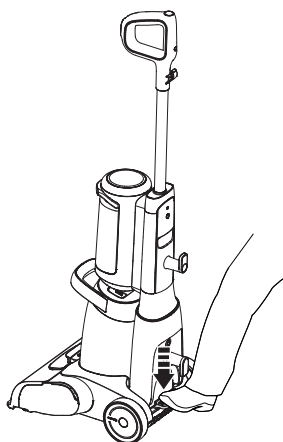

Unwrap the power cord and plug into an electrical outlet.



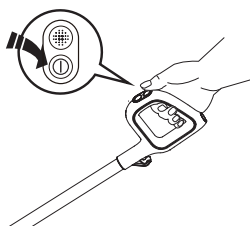

Step on the recline pedal to recline the unit for cleaning position.

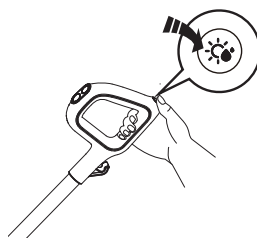

Press the  button and the appliance will start in AUTO mode by default. Press it again to turn off the appliance. Switch between AUTO and MAX mode by pressing the  button.



Press the  button and the appliance will start in Dry mode, press it again to stop DRY mode. Switch back to original mode by pressing the  button.

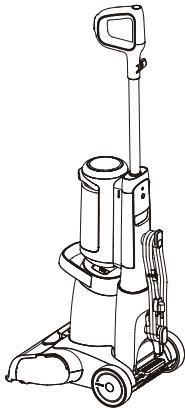

Stop Working

In AUTO/MAX and Dry mode, the appliance will stop working when put uprightly and start running again when you recline.

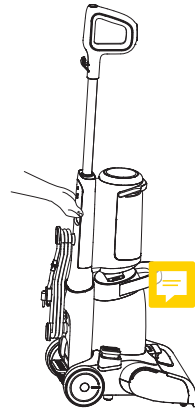

Grip the back carry handle to lift or move appliance. Empty CWT and DWT after each use.

### Note:

- The carpet cleaner differs from the traditional vacuum cleaner.
- In all modes, it blows hot air, whose temperature is 70-80°C.  
\* Appropriate temperature is conducive to dissolve the dirt and helps surfactant in the solution to decompose the dirt.
- In AUTO/MAX mode, it sprays water when moving forward and stops spraying when moving backward.
- Take a spot test on a small and marginal area of the carpet for colorfastness. Gently rub surface with a damp white cloth. Then wait ten minutes and check for color removal or bleed with a white paper towel.
- Do not grip DWT handle to lift or move the appliance.





## Preparing for Use (Accessory Hose & 2 in 1 Nozzle)

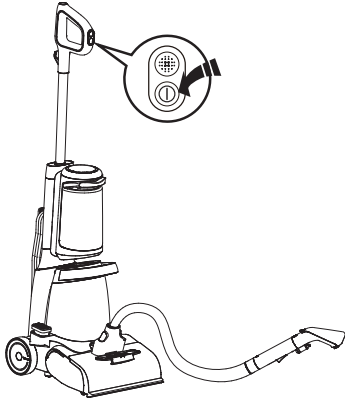

Attach the accessory hose, stand the appliance upright and ensure that it is power on (if not, press the  button), the appliance will enter in ACCESSORY Mode, the appliance will stop working when you recline.

### Note:

- Do not vacuum foamed liquid.

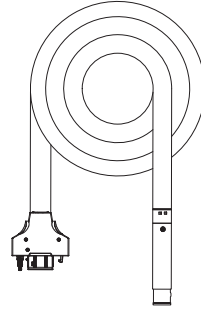

Store the accessories in the bag after use.

# Cleaning Mode Selection

## AUTO Mode



### AUTO



Blue

Clean: on Min spray volume



The default spray volume is "60", vary depending on dirt amount



Red

Heavy dirt: on Max spray volume

- In AUTO mode, the iLoop™ sensor automatically detects how dirty the carpet is and applies the appropriate volume of water spray.
- A red dirt monitoring loop indicates more dirt is detected, and a blue loop indicates less dirt is detected. This mode automatically provides the best cleaning solution.

## MAX Mode

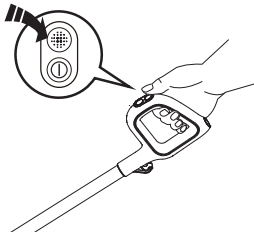

- In AUTO mode, press the AUTO/MAX button to enter MAX mode. The AUTO indicator on the display will turn off.
- The iLoop only displays the dirty amount, and the spray volume keeps at the maximum of "100".
- In MAX mode, the appliance will apply max spray volume.

## DRY Mode

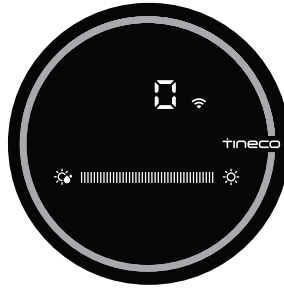
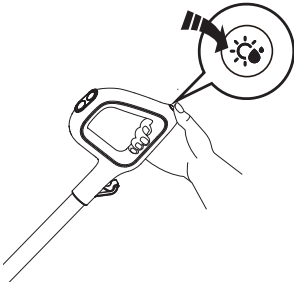

Wet



Changes with the degree of humidity



Dry

- Press the DRY button to enter DRY mode, in DRY mode, the dry degree indicator will change with the humidity detected by the humidity sensor.
- Press the DRY button again to stop DRY mode, and press the  button to switch to the original mode.

## ACCESSORY Mode

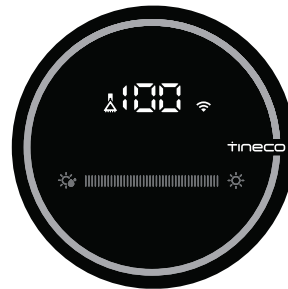
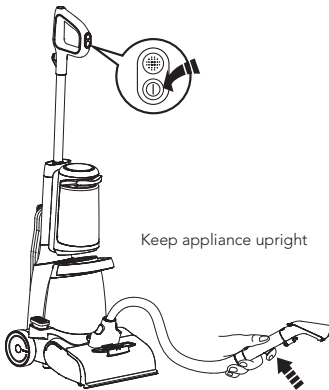

- Ensure the appliance is power on (if not, press the  button), the appliance will enter into ACCESSORY Mode. Press and hold the button on the 2 in 1 Nozzle to spray water, and release the button to stop.
- In ACCESSORY Mode, the accessory icon is illuminated and the spray volume keeps at the maximum of "100".
- Stand the appliance upright, remove the accessory hose, the appliance will enter in AUTO mode.

### Note:

Keep sharp objects away from the digital display screen to avoid scratches and scrapes.

# Indicator

## When in Use



MAX mode  
Spray volume indicator: solid "100".



Appliance enters standby mode when stand upright in Max mode.



AUTO mode  
Spray volume indicator: changes.



Appliance enters standby mode when stand upright in Auto mode.



DRY mode  
Spray volume indicator: Solid "0", Dry Degree Indicator illuminated.



ACCESSORY mode  
Spray volume indicator: solid "100".  
Accessory icon: illuminated.



Appliance enters standby mode when recline in Accessory mode.



Accessory icon: blinks.  
Spray volume indicator: solid "0".  
See Troubleshooting.



AUTO icon: blinks.  
Spray volume indicator: solid "0".  
See Troubleshooting.



No spray volume display: pump malfunction.



Solid red light: dirt sensor malfunction or blocked.



Indicator blinking: CWT is empty.



Indicator blinking: DWT is full or channel has a blockage.  
DWT is not installed.



Indicator blinking: brush roller cover is not installed or brush roller has a blockage.



Illuminated: WiFi has successfully connected.



Blinking: WiFi is connecting.



Off: WiFi is not connected, please connect to the network.



Dry degree indicator blinks, humidity sensor malfunction.

## App

All the functions can be performed using the Tineco app. Download the Tineco app from the App Store, Google Play and Tineco Official Site.

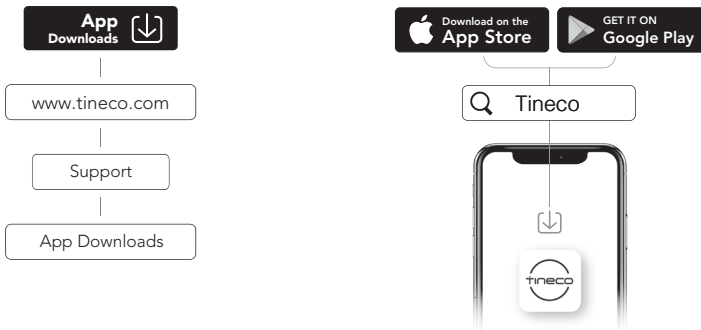

### Note:

The default setting for voice prompt is English, you can set other languages via App.

## Voice Prompt (Contents may vary, please in kind prevail.)

Status	Reminder
WiFi network connected	Network connected.
Voice prompts on	Voice prompts on
Voice prompts disabled	Voice prompts disabled
Auto mode by default	AUTO mode
Switch to Max mode	Max mode
Switch to Dry mode	DRY mode
Switch to Accessory mode	Accessory Mode
Clean Water Tank is empty	Please add clean water or solution to clean water tank
Dirt sensor malfunction or blocked	Clean the channel under the dirty water tank
Dirty Water Tank is full	Dirty water tank full, please empty.
Dirty Water Tank not installed correctly	Please check the dirty water tank
Brush roller is tangled	Please clean the brush roller.
Brush roller cover not installed	Please install the brush roller cover
In accessory mode, switch to other modes	Remove accessory before using other modes
In accessory mode, switch to DRY mode	Remove accessory before using DRY mode
Operate accessory mode	Stand the appliance upright to operate accessory mode
Stand the device upright	Stand the device upright
Accessory installed, start cleaning	Accessory installed, start cleaning
Accessory removed, start AUTO mode	Accessory removed, now in AUTO mode
Shutting down	Shutting down
Power is off	Power off, please clean the dirty water tank

# Maintenance

## Note:

- For optimal performance and to prevent odors, always **clean** and **dry** DWT, filter, brush roller, brush roller cover, 2 in 1 nozzle, **completely** after each use.
- Please make sure each part is installed correctly or the appliance may not work properly.
- After maintenance, place the appliance vertically. Do not expose the appliance to direct sunlight, and store it indoors in a dry place.

## Main Body

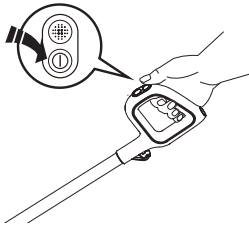

To reduce the risk of injury, switch off before performing maintenance.



Use a cloth to clean the surface with a neutral detergent. The cloth should be dry to prevent water from entering the appliance.

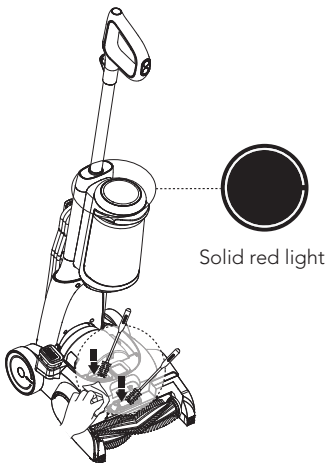

When LED loop illuminates red, remove Dirty Water Tank, clean the dirt sensor with a damp cloth or the cleaning tool.

## Dirty Water Tank

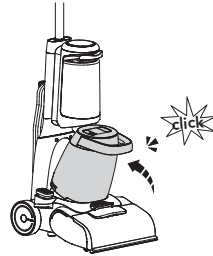
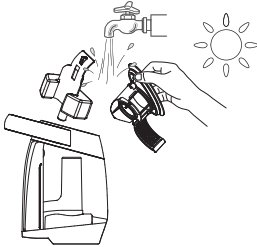
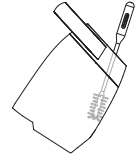
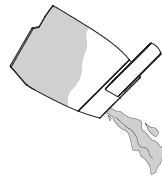
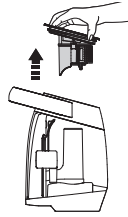
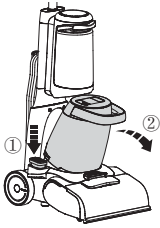

- When dirty water reaches the Max line, the appliance will stop working and show a reminder on the display and play a voice prompt.
- Step on the recline pedal and press the DWT handle to remove it.
- Pull up the tank lid to empty the DWT. Use the cleaning tool to remove remaining debris. Rinse the inside of the DWT & tank lid & floater and place back into the appliance.

## Filter

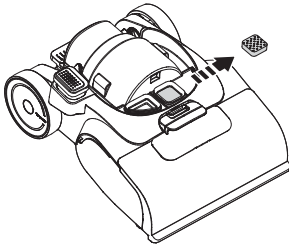

Remove the DWT, take the filter out and wash it after each use.

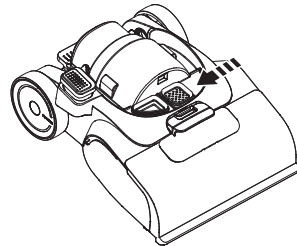

Reinstall.