

Test Report

Product	Seismic Data Acquisition unit		
Name and address of the applicant	WesternGeco AS Risabergvegen 3, 4056 Tananger , Norway		
Name and address of the manufacturer	WesternGeco AS Risabergvegen 3, 4056 Tananger , Norway		
Model	Cheetah Logger v6		
Rating	Internal battery 3.6V		
Trademark	WesternGeco		
Serial number	SN 2300110840 PN 102976430		
Additional information	-		
Tested according to	FCC Part 15, subpart B Other Class B Digital Device Industry Canada ICES-003, Issue 6 Information Technology Equipment (ITE)		
Order number	362 179		
Tested in period	2018.12.01 – 2019.01.31		
Issue date	2020.09.22		
Name and address of the testing laboratory	 Instituttveien 6 Kjeller, Norway www.nemko.com	CAB Number: FCC: NO0001 ISED: NO0470 TEL: +47 22 96 03 30 FAX: +47 22 96 05 50	  An accredited technical test executed under the Norwegian accreditation scheme
	 Prepared by [Jan G Eriksen]	 Approved by [G.Suhanthakumar]	
This report shall not be reproduced except in full without the written approval of Nemko. Opinions and interpretations expressed within this report are not part of the current accreditation. This report was originally distributed electronically with digital signatures. For more information contact Nemko.			

CONTENTS

1	INFORMATION	3
1.1	Tested Item.....	3
1.2	Test Environment.....	3
1.3	Test Engineer(s).....	3
1.4	Test Equipment.....	3
1.5	Other Comments	3
2	TEST REPORT SUMMARY	4
2.1	General.....	4
2.2	Test Summary	5
3	TEST RESULTS.....	6
3.1	Spurious Emissions (Radiated).....	6
4	MEASUREMENT UNCERTAINTY	9
5	TEST SETUPS	10
5.1	Radiated Emissions Test.....	10
5.2	Power Line Conducted Emissions Test	10
6	TEST EQUIPMENT USED	11

1 INFORMATION

1.1 Tested Item

Name	Seismic Data Acquisition unit
Model name	Cheetah Logger v6 PN: 102976430
FCC ID	2ASOK-CLOG6
Industry Canada ID	N/A
FCC / IC Class	B
Serial number	SN: 2300110840
Hardware identity and/or version	102976430 v6
Software identity and/or version	LoggerAppRevFKeil-20190319-123845
Desktop Charger	NA – The loggers will be charged in a charging rack where up to 540 loggers are charged simultaneously.

Description of Tested Device(s)

The tested equipment is a seismic logger which is deployed slightly below the surface of earth. The device contains a GNSS receiver.

1.2 Test Environment

Temperature:	20 – 25 °C
Relative humidity:	30 – 50 %
Normal test voltage:	Internal battery 3.6 V

The values are the limit registered during the test period.

1.3 Test Engineer(s)

Jan G Eriksen

1.4 Test Equipment

See list of test equipment in clause 6.

1.5 Other Comments

None

2 TEST REPORT SUMMARY

2.1 General

All measurements are traceable to national standards.

All tests were performed in accordance with ANSI C63.4-2014 where applicable. Radiated emissions are made in a 10m semi-anechoic chamber. A description of the test facility is on file with FCC and Industry Canada.



THIS TEST REPORT APPLIES ONLY TO THE ITEM(S) AND CONFIGURATIONS TESTED.

Deviations from, additions to, or exclusions from the test specifications are described in "Summary of Test Data".

Nemko Group authorizes the above named entity to reproduce this report provided it is reproduced in its entirety and for use by the entity's employees only. Any reproduction of parts of this report requires approval in writing from Nemko Group.

Any use that a third party makes of this report, or any reliance on or decisions to be made based on it, are the responsibility of such third parties. Nemko Group accepts no responsibility for damages suffered by any third party caused by decisions made or actions based on this report.

2.2 Test Summary

Name of test	FCC CFR 47, Paragraph #	ISED RSS-GEN, Issue 5, Paragraph #	ISED ICES-003, Issue 6, Paragraph #	Verdict
Power Line Conducted Emission	15.107(a)	7.2 / 8.8	6.1	Not applicable
Spurious Emissions (Radiated)	15.109	7.3 / 8.9	6.2	Complies
Labelling Requirements	15.19	4	8	-

3 TEST RESULTS

3.1 Spurious Emissions (Radiated)

FCC Part 15.109

ISED ICES-003 Issue 6, Clause 6.2

ANSI C63.4-2014, clause 8.

Test Results:

Radiated emission 30 – 1000 MHz

Measuring distance 10 m, Peak Detector.

Measurement and limit according to CISPR 22 Class B devices

The EUT were rotated 360 degrees and the antenna height varied between 1 and 4 m on all found frequencies.

No component detected, see attached graphs.

Radiated Emissions 1000 – 6000 MHz

Detector: Quasi-Peak

Measuring distance 3 m

Measurement and limit according to FCC Part 15 Clause 15.109, Class B devices

The EUT were rotated 360 degrees and the antenna height varied between 1 and 4 m on all found frequencies.

No spurious components detected, see attached graphs.

Frequency MHz	Dist. corr. Factor dB	Field strength @3m QP Det., dB μ V/m	Limit dB μ V/m	Margin dB
30-1000	0	All peak detector measurements are more than 10 dB below limit	See below	> 10
1000-6000 HP	0	All peak detector measurements are more than 15 dB below average limit	See below	> 15
1000-6000 VP	0	All peak detector measurements are more than 15 dB below average limit	See below	> 15

Requirements/Limit

FCC	Part 15.109 @ frequencies defined in §15.205	
ISED	RSS-GEN Issue 5, Clause 8.9 @ frequencies defined in clause 8.10	
	Radiated emission limit @3 meters	
Frequency (MHz)	Quasi Peak (μ V/m)	Quasi Peak (dB μ V/m)
30 – 88	100	40.0
88 – 216	150	43.5
216 – 960	200	46.0
Above 960	500	54.0

¹ The limit above 1000 MHz is specified for Average Detector, when the measurement is performed with a Peak Detector a Duty-Cycle Correction Factor has to be calculated to find the corresponding Average Detector value.

Full Spectrum

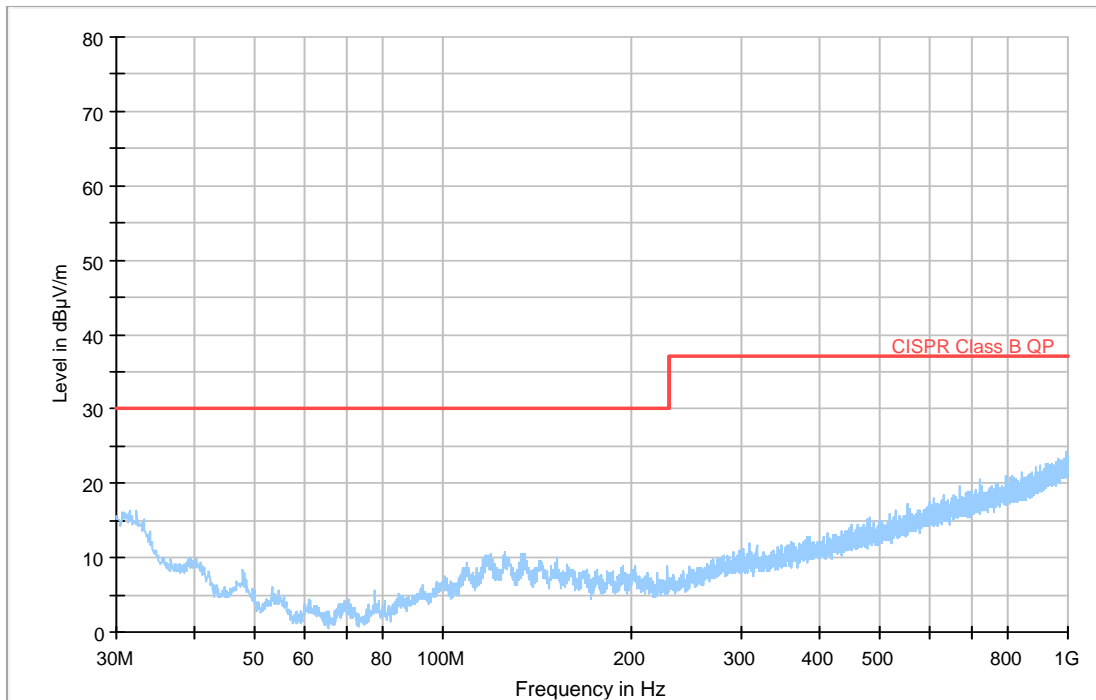

30-1000 MHz, VP&HP, EUT rotated 0-360 degrees at tree antenna heights.

Full Spectrum

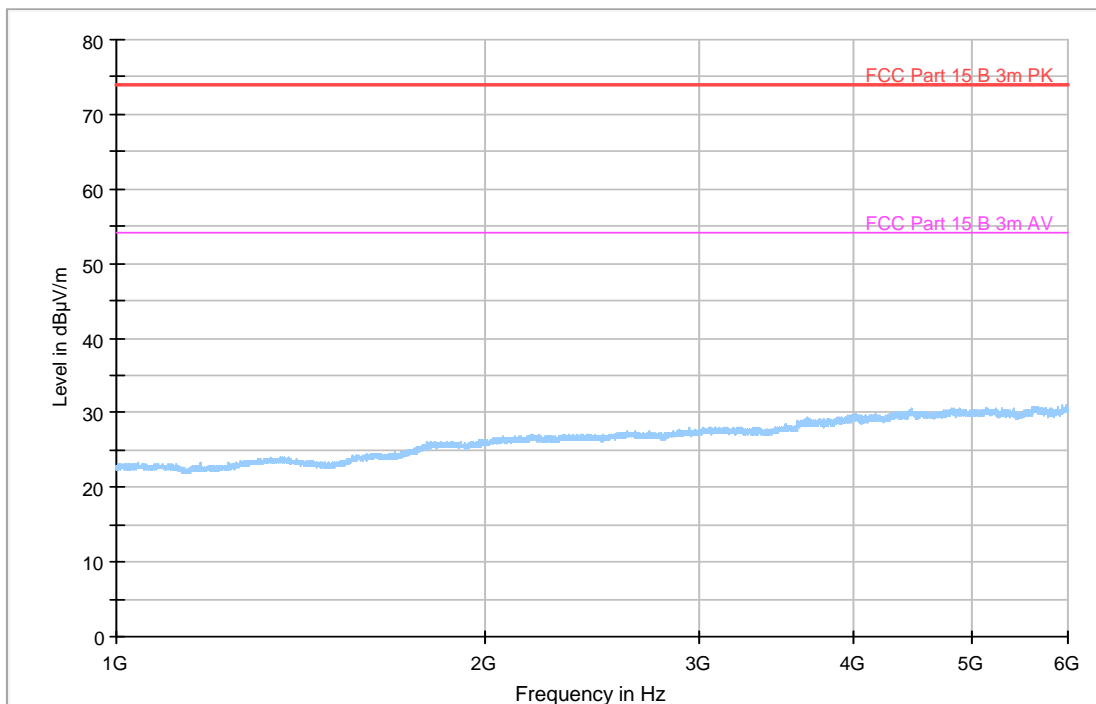

1000-6000 MHz HP, EUT rotated 0-360 degrees at 120 cm height

Full Spectrum

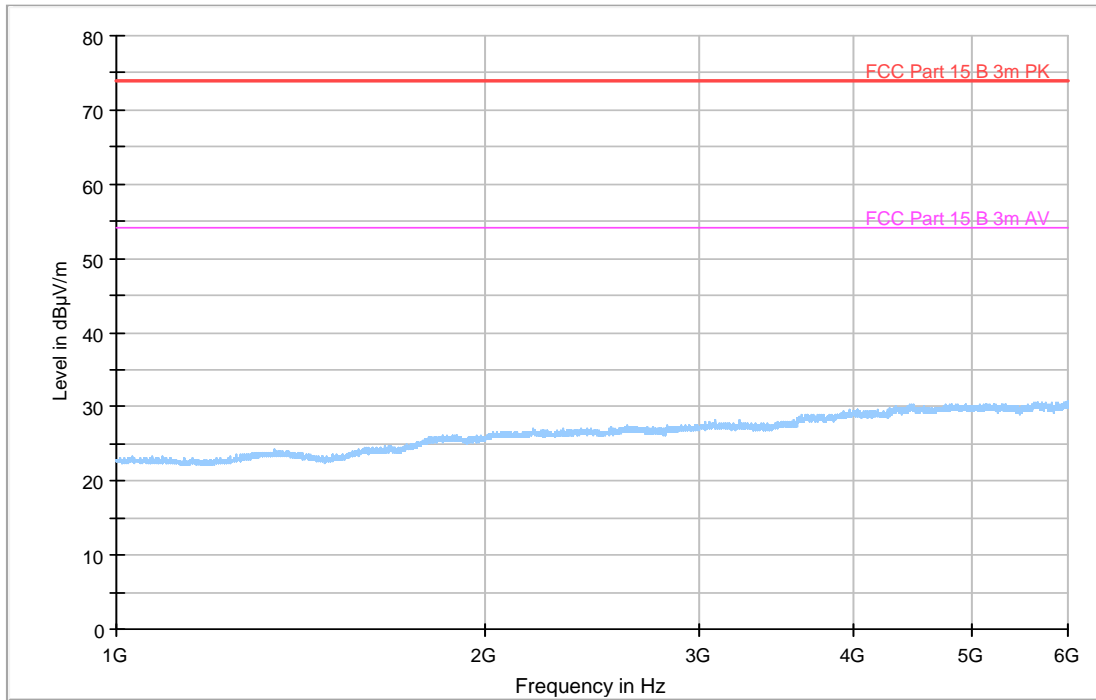

1000-6000 MHz VP, EUT rotated 0-360 degrees at 120 cm height

4 Measurement Uncertainty

Measurement Uncertainty Values		
Test Item		Uncertainty
Spurious Emissions, Radiated	< 1 GHz	±2.5 dB
	> 1 GHz	±2.2 dB
Power Line Conducted Emissions		+2.9 / -4.1 dB
Temperature Uncertainty		±1 °C

All uncertainty values are expanded standard uncertainty to give a confidence level of 95%, based on coverage factor k=2

5 Test Setups

5.1 Radiated Emissions Test

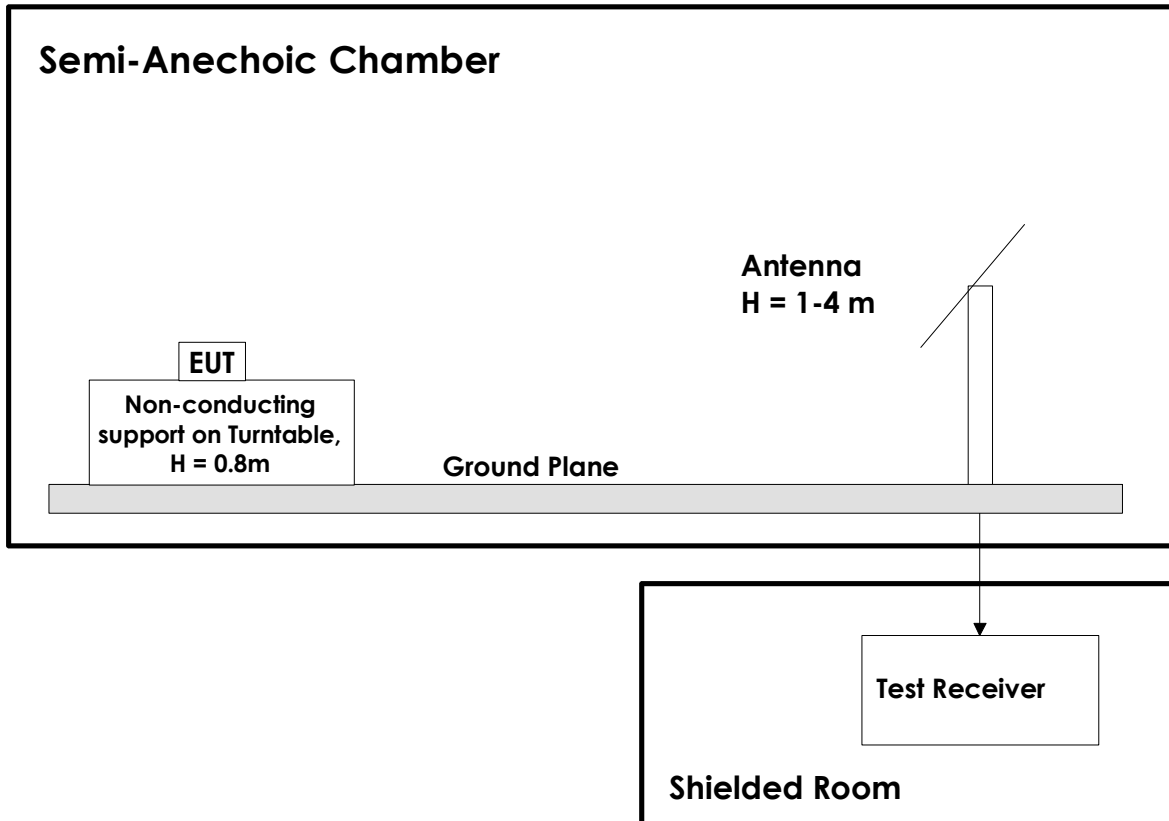

Test Set-Up 1

This test setup is used for all radiated emissions tests. For frequencies below 30 MHz the measuring distance is 10m, for all other frequencies it is 3m or 1m. Emissions above 1 GHz are measured with a Spectrum Analyzer and Horn Antenna. For measurements above 18 GHz the test receiver is moved inside the anechoic chamber and located next to the antenna to minimize the cable loss. All measurements at 1GHz and above were performed with turntable height 1.5m and with the ground plane covered by absorbers. A pre-amplifier is used for all measurements above 30 MHz.

5.2 Power Line Conducted Emissions Test

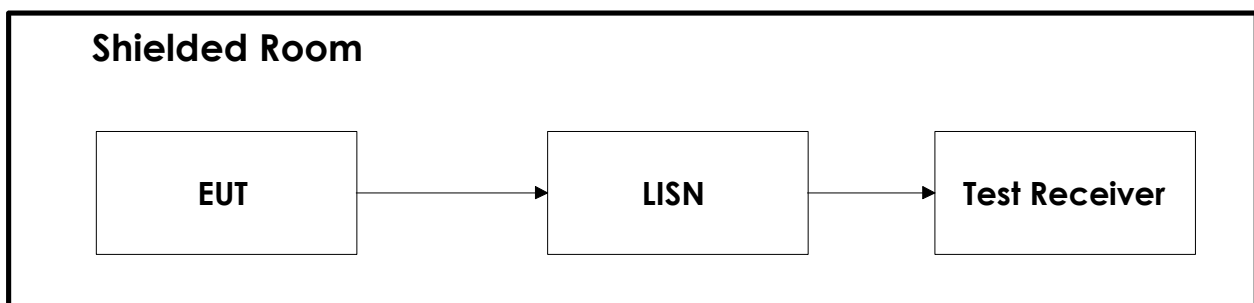

Test Set-Up 2

6 Test Equipment Used

To facilitate inclusion on each page of the test equipment used for related tests, each item of test equipment and ancillaries are identified (numbered) by the Testhouse.

No.	Model number	Description	Manufacturer	Ref. no.	Cal. date	Cal. Due
2	ESU40	Measuring Receiver	Rohde & Schwarz	LR-1639	01/2019	01/2020
4	JB3	Antenna Bilog	Sunol	N-4525	11/2018	11/2019
5	3117-PA	Antenna Horn	EMCO	LR-1717	12/2018	12/2019
6	310N	Preamplifier	Sonoma	LR-1686	07/2018	07/2019

The software listed below has been used for one or more tests in this report.

No.	Manufacturer	Name	Version	Comment
1	Rohde & Schwarz	ES-K1	1.71 SP2	Power Line Conducted test software
2	Rohde & Schwarz	EMC32	9.26.01	Radiated Emission test software
3	Rohde & Schwarz	GPIBShot	2.7	Screenshots from R&S Spectrum Analyzers

Revision history

Revision	Date	Comment	Sign
00	2019-06-07	First edition	JGE
01	2020-09-22	Updated references	FS