

SPECIFICATION FOR APPROVAL

CUSTOMER: Peng Yuansheng

702-090000-032
 CUST P/N: _____
 FINE P/N: _____
 DESC: **F19.5x27.5-9Ts-3coil-27mm-F**

 DATE: **2020/07/09**

 Version: **A.0**

PREPARED BY	CHECKED BY	APPROVED BY	CUSTOMER APPROVE
Guo Runqing	Cai Jiyu	Ni Xing	

FINE ELECTRONICS INDUSTRIAL (HK) LIMITED

Factory address: Sijia Industrial Zone, Shijie
 Town, Dongguan City

TEL: 0769-22490287 / 22452492

FAX: 0769-22499451

E-mail: fineelec@163.com



SPECIFICATION

DESC	F19.5x27.5-9Ts-3coil-27mm-F	Rev: A.0	CUST:	Peng Yuansheng
			Fine P/N:	
			CUST P/N:	702-090000-032

一、 DIMENSION:(mm)

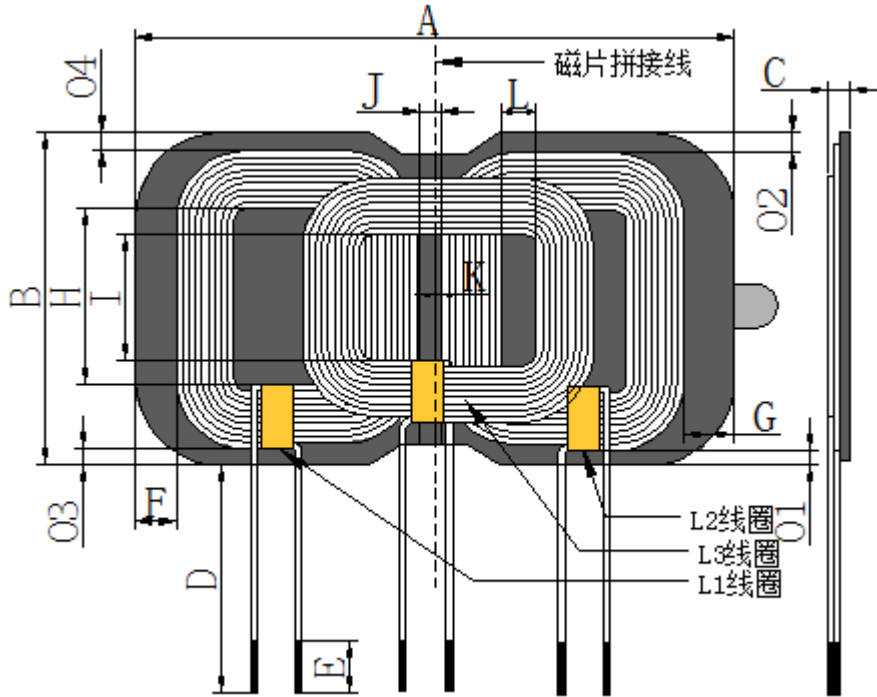

A	93.0±1.2
B	51.5±0.8
C	4.0±5%
D	27±2
E	1-4
F	3-4.5
G	6.5 ref
H	27.5±0.5
I	19.5±0.5
J	2.0-3.5
K	0-0.8
L	6.0 ref
01/02/03/04	≥0.8

Note:

1. The coil is pasted with F46.5 ± 0.6x51.5 ± 0.8mm, with a thickness of 1.0 ± 0.1mm, and is made by splicing two hard magnetic sheets.
2. On the back of the magnetic disc, there is a white double-sided adhesive tape with a hand torn position.
3. Wrap 8mm high-temperature adhesive paper 1-2Ts around the outlet position;
4. The top and bottom of the coil magnetic sheet need to be symmetrical;
5. The inner ring of L3 coil should be pressed against one inner ring of L1 coil

二、 SCHEMATIC DIAGRAM:

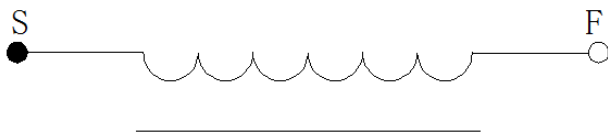

三、 Winding Specification:

The line is fixed with acetone;

NO.	TERMINAL		WIRE	Turns	Winding Direction
	S	F			
L1	S	F	Silk wrapped thread Φ 0.08 * 105 shares	9Ts	CCW(Assembly drawing)
L2	S	F	Silk wrapped thread Φ 0.08 * 105 shares	9Ts	CW(Assembly drawing)
L3	S	F	Silk wrapped thread Φ 0.08 * 105 shares	9Ts	CW(Assembly drawing)

四、 ELECTRICAL CHARACTERISTICS:

TEMPERATURE:25±10℃, RELATIVE HUMIDITY:65±20%

NO.	ITEM	TERMINAL	SPECIFICATION	TEST FREQUENCY	TEST EQUIPMENTS
L1 Coil	IND.	S-F	7.10uH ± 10%	100KHz/1.0V	LCZ METER 1062B
L2 Coil	IND.	S-F	7.10 uH ± 10%	100KHz/1.0V	LCZ METER 1062B
L3 Coil	IND.	S-F	6.60uH ± 10%	100KHz/1.0V	LCZ METER 1062B
L1/2/3	DCR	S-F	55mΩ Max		LCZ METER 502B

PREPARED BY/DATE	CHECKED BY/DATE
Guo Runqing 2020/07/09	Cai Jiyu 2020/07/09

SPECIFICATION

DESC	F19.5x27.5-9Ts-3coil-27mm-F L1 coil	Rev: A.0	CUST:	Peng Yuansheng
			Fine P/N:	
			CUST P/N:	702-090000-032

一、 DIMENSION:(mm)

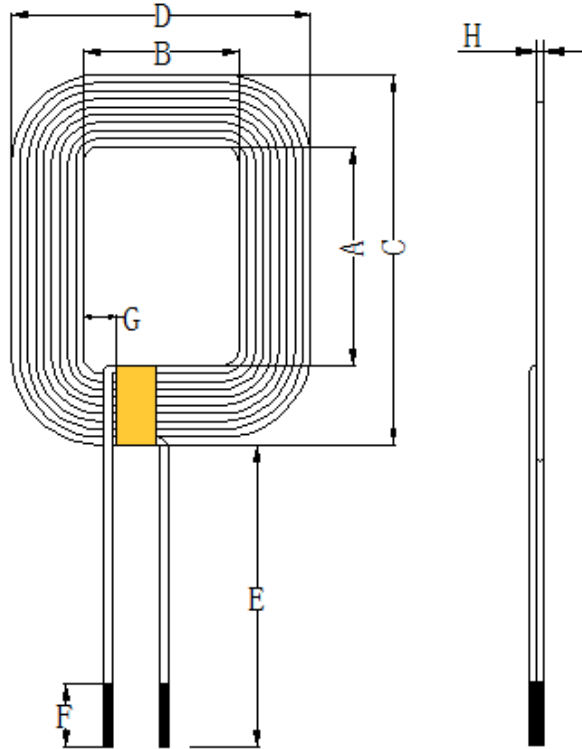

A	27.5±0.5
B	19.5±0.5
C	48.0±1.0
D	39.5-41
E	28 ref
F	1-3.5
G	3.0ref
H	1.35 Max

Note:

- 1.Short side cross outgoing line;
- 2.Wrap 8mm high-temperature adhesive tape 1-2Ts around the outlet position;

二、 SCHEMATIC DIAGRAM:



三、 Winding Specification:

NO.	TERMINAL	WIRE	Turns	Winding Direction
1	S F	Silk wrapped thread Φ 0.08 * 105 shares	9Ts	CCW

四、 ELECTRICAL CHARACTERISTICS:

TEMPERATURE:25±10 °C, RELATIVE HUMIDITY:65±20%

NO.	ITEM	TERMINAL	SPECIFICATIO N	TEST FREQUENCY	TEST EQUIPMENTS
1	IND.	S-F	4.1uH±10%	100KHz/1.0V	LCZ METER 1062B
2	DCR	S-F	55mΩ Max		LCZ METER 502B

PREPARED BY/DATE	CHECKED BY/DATE
Guo Runqing 2020/07/09	Cai Jiyu 2020/07/09

SPECIFICATION

DESC	F19.5x27.5-9Ts-3coil-27mm-F L2 Coil	Rev: A.0	CUST:	Peng Yuansheng
			Fine P/N:	
			CUST P/N:	702-090000-032

一、 DIMENSION:(mm)

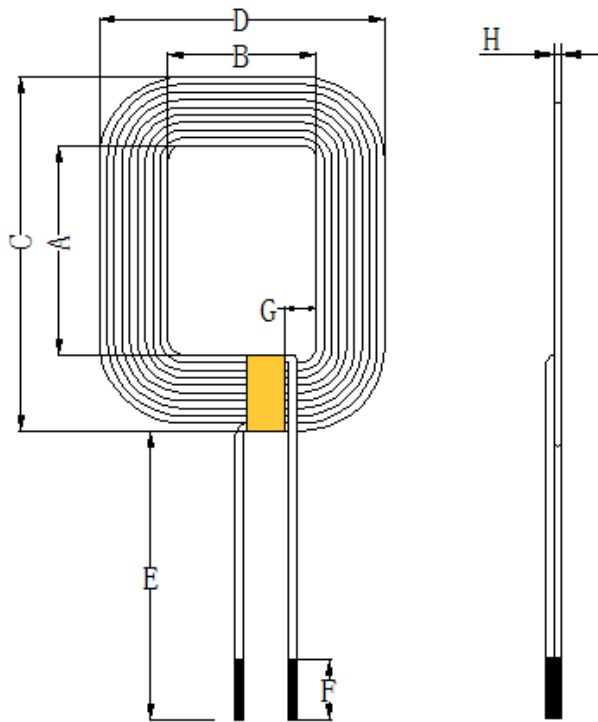

A	27.5±0.5
B	19.5±0.5
C	48.0±1.0
D	39.5-41
E	28 ref
F	1-3.5
G	3.0ref
H	1.35 Max

Note:

1. Short side cross outgoing line;
2. Wrap 8mm high-temperature adhesive paper 1-2Ts around the outlet position;

二、 SCHEMATIC DIAGRAM:



三、 Winding Specification:

NO.	TERMINAL		WIRE	Turns	Winding Direction
1	S	F	Silk wrapped thread Φ 0.08 * 105 shares	9Ts	CW

四、 ELECTRICAL CHARACTERISTICS:

TEMPERATURE:25±10 °C, RELATIVE HUMIDITY:65 ±20%

NO.	ITEM	TERMINAL	SPECIFICATION	TEST FREQUENCY	TEST EQUIPMENTS
1	IND.	S-F	4.1uH ±10%	100KHz/1.0V	LCZ METER 1062B
2	DCR	S-F	55mΩ Max		LCZ METER 502B

PREPARED BY/DATE	CHECKED BY/DATE
Guo Runqing 2020/07/09	Cai Jiyu 2020/07/09

SPECIFICATION

DESC	F19.5x27.5-9Ts-3coil-27mm-F L3 Coil	Rev: A.0	CUST:	Peng Yuansheng
			Fine P/N:	
			CUST P/N:	702-090000-032

一、 DIMENSION:(mm)

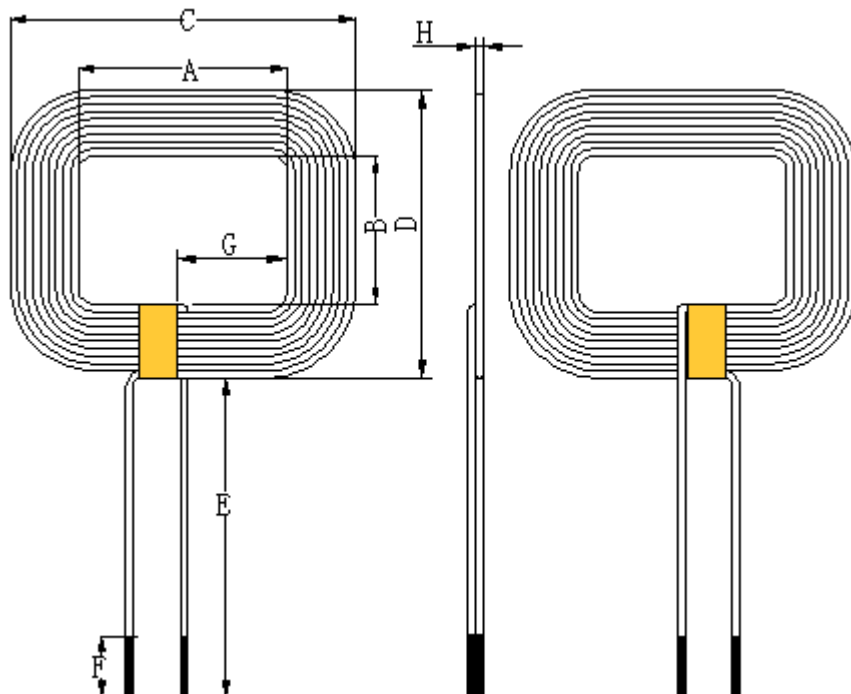

A	27.5±0.5
B	19.5±0.5
C	47.5±1.0
D	40.5±1.0
E	33 ref
F	1-3.5
G	15.0±1.5
H	1.35 Max

Note:

1. Long side cross outgoing line;
2. Wrap 8mm high-temperature adhesive paper 1-2Ts around the outlet position;

二、 SCHEMATIC DIAGRAM:

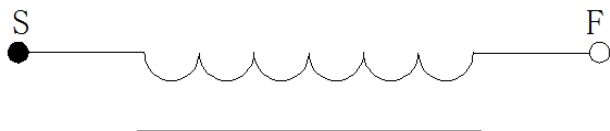

三、 Winding Specification:

NO.	TERMINAL	WIRE	Turns	Winding Direction
1	S F	Silk wrapped thread Φ 0.08 * 105 shares	9Ts	CCW

四、 ELECTRICAL CHARACTERISTICS:

TEMPERATURE:25±10 ℃, RELATIVE HUMIDITY:65±20%

NO.	ITEM	TERMINAL	SPECIFICATION	TEST FREQUENCY	TEST EQUIPMENTS
1	IND.	S-F	4.1uH ± 10%	100KHz/1.0V	LCZ METER 1062B
2	DCR	S-F	55mΩ Max		LCZ METER 502B

PREPARED BY/DATE	CHECKED BY/DATE
Guo Runqing 2020/07/09	Cai Jiyu 2020/07/09

SPECIFICATION

DESC	F19.5x27.5-9Ts-3coil-27mm-F	Rev: A.0	CUST:	Peng Yuansheng
			CUST P/N:	702-090000-032

五、 Material List:

NO.	Material name	Description	Martnumber	Material
1	silk covered wire	Single root Φ 0.08 enameled wire * 105 strands		Pure copper
2	Solder Bar	High temperature		
3	Acetone water	Viscous solution		
4	glue	Resin adhesive		
5	Double magnetic disc	F46.5*51.5*thick 1mm		Ferrite, manganese zinc, PC40
6	double-sided tape	F93*51.5 Hand tear position		
7	Pearl cotton			
8	carton			
9				
10				
11				
12				
13				
14				
15				

PREPARED BY/DATE	CHECKED BY/DATE
Guo Runqing 2020/07/09	Cai Jiyu 2020/07/09