

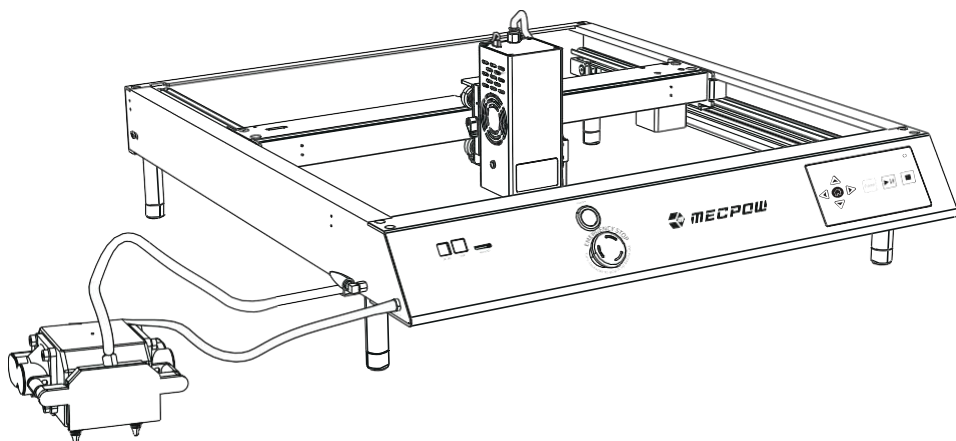

X4



User Manual

CATALOGUE

ENGLISH.....	01~20
DEUTSCHE.....	21~41
ESPAÑOL.....	42~62
FRANÇAIS.....	63~83
ITALIANO.....	84~104
POLSKI.....	105~125

CONTENTS

1. Preface.....	01
2. Security Statement.....	01
3. Diagram.....	02
4. Specifications.....	04
5. Package List.....	04
6. Assembly Guide.....	05
7. Functions & Operations.....	08
8. Driver.....	10
9. Control via Computer Software.....	11
10. Control via Control Panel & TF Card.....	16
11. Control via Mobile App & TF Card.....	17
12. Recommended Operating Parameters.....	18
13. Troubleshooting.....	18
14. Compliance Statement.....	20

1. Preface

Dear Customer,

Thank you for purchasing our laser engraving machine. This device is a high-tech product that integrates light, machinery, and electricity. In order for you to use and maintain the equipment better, please read the user manual carefully and follow the steps in the manual.

Disclaimer

Any losses caused by improper use or failure to follow the steps in the user manual will be borne by the individual. The final interpretation of the user manual belongs to our company, and we reserve the right to modify any information, data, technical details, etc. in the manual.

2. Security Statement

Safety Precautions

* Laser processing can be risky, and users should carefully consider whether the object to be processed is suitable for laser work.

* The object being processed and emissions must comply with local laws and regulations.

* This machine uses a Class IV laser (high-power laser radiation), which may cause the following situations:

(1) Ignition of surrounding flammable materials;

(2) During laser processing, other radiation and toxic and harmful gases may be produced, depending on the object being processed;

(3) Direct exposure to laser radiation can cause harm to the human body. There must be fire-fighting equipment in the workplace, and flammable and explosive materials must not be stacked around the workbench or machine. Good ventilation must also be maintained.

* The environment in which the machine is located should be dry, free from pollution, vibration, strong electricity, strong magnetism and other interference. The working ambient temperature should be 5-30°C, and the working ambient humidity should be 35-65%RH.

* The working voltage of the machine is AC100-240V.

* During the operation of the machine, it must be monitored throughout. Before leaving, all power must be cut off to prevent any unforeseen issues. If an abnormal situation occurs, please immediately cut off the power and deal with it!

* It is strictly prohibited to place any reflective or diffuse objects in the machine that are not relevant to its operation to prevent laser reflection on the human body or flammable materials.

* The machine should be kept away from electrical equipment sensitive to electromagnetic interference, which may cause electromagnetic interference to it.

* It is strictly forbidden for non-professionals to disassemble the laser engraver as there may be dangers such as high voltage inside the machine.



Warning

1. The laser engraving machine can produce laser light. It is strictly prohibited to place any living organisms under the laser emission (the port is marked with a yellow warning sign).
2. Photosensitive patients are prohibited from using or getting close to the laser engraver.
3. When using the laser engraving machine, the operator and anyone near the machine must wear laser safety glasses. Do not operate the laser machine without laser goggles. Our machine comes with a pair of laser safety glasses. If you want to purchase additional goggles, the goggles should offer wavelength protection between 400-445nm (+5nm), have an outer diameter of +5, and meet a minimum L5 level.
4. When the laser engraving machine is in operation, the user must pay close attention and not leave it unattended to avoid ignition of the engraved material. Place the machine in a fireproof area and ensure good ventilation. It is recommended to have a fire extinguisher nearby in case of emergencies.
5. Make sure there are no flammable materials near the laser engraving machine. We recommend placing a honeycomb working table under the machine.

6. When operating the laser engraver, ensure that there is enough space around it. Engraving certain materials may produce smoke, which should be vented out using a specialized exhaust system.
7. Do not touch the laser beam or the object being processed while the machine is in operation, as this could cause serious injury or beam reflection. Additionally, avoid touching the radiator as it may be hot due to the laser engraving machine working or just recently stopping.
8. Children or teenagers (especially those under 14 years old) are not allowed to use the laser engraving machine alone and should be supervised by an adult at all times.
9. The operating temperature of the machine is 41°F-86°F (5°C-30°C).
10. Switch the machine off when it is not in use to avoid misuse by third parties.
11. When laser engraving, there is a risk of fire. When the laser engraving machine is in use, it must be supervised by a skilled operator who can use a fire extinguisher to handle any accidents that may occur.
12. Our laser engraving machine is equipped with a built-in flame sensor to maximize the safety of our equipment. But please note that no written or implied warranty is made regarding the availability or functionality of the flame sensor.

Maintenance

Recommendations:

Switch off the machine for 10 minutes after 4 hours of engraving and 10 minutes after 1 hour of cutting.

The laser module is consumable.

3. Diagram

1. Right Y-Axis
2. Rear X-Axis
3. Left Y-Axis
4. X-Axis Assembly
5. Device for Adjusting the X-Axis Belt
6. Laser Module
7. Front X-Axis
8. Air Pump

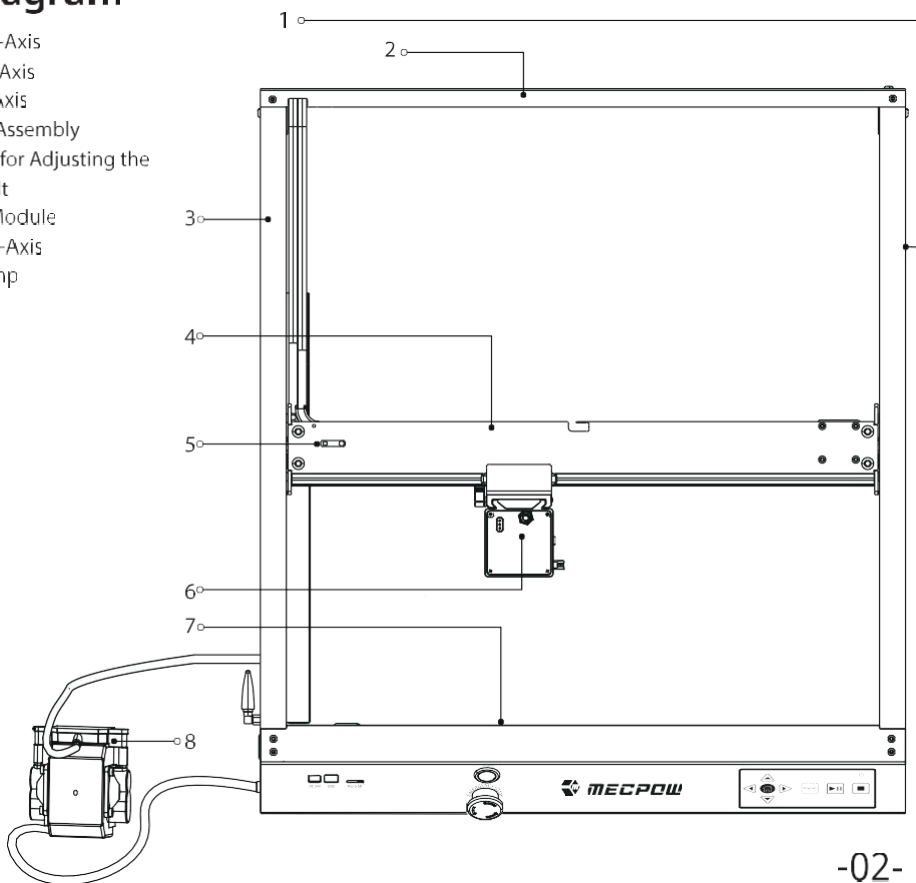

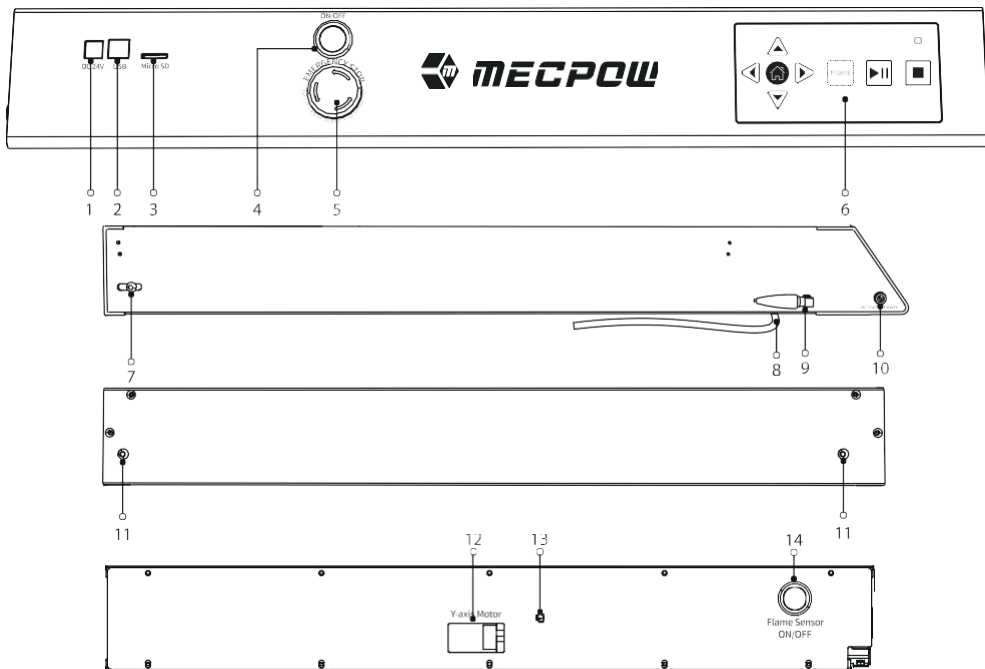

- | | | |
|--------------------------|-------------------------------------|--|
| 1. DC Input Port | 6. Control Panel | 11. Screws for Adjusting the Y-Axis Belt |
| 2. USB Port | 7. Screw for Fixing the Y-Axis Belt | 12.Y-Axis Motor |
| 3. Micro SD Port | 8. Hose for Air Pump | 13. Flame Sensor |
| 4. Power Switch | 9. WiFi Antenna | 14. Flame Sensor Switch |
| 5. Emergency Stop Button | 10. Air Assist Interface | |









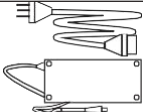
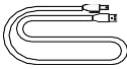

Control Panel Introduction

Key Icons	Key Name	Key Function
	Arrow Keys	Briefly press one of the keys, and the laser module will move 1mm in the corresponding direction. Long press the key for 3 seconds or more, and the laser module will keep moving till you release the key or the laser module hits the limit switch.
	Home	Press this key to return the laser module to the original position.
	Patrol Key	Press this key and the laser module will patrol the working area of the first G-code file in the TF card.
	Start/Pause Key	Press this key to start/pause engraving.
	Stop Key	Press this key to terminate engraving.
	TF Card Indicator	Light on when the TF card is detected and read.

4. Specifications

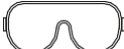
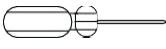
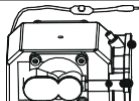
Model	X4	
Basic Specifications	Product Size	685x620x190mm
	Package Size	715x645x145mm
	Weight	10.6kg
	Input Voltage	DC 24V
	Rated Power	144W
	Max. Engraving Area	410x400mm
	Max. Engraving Speed	22000mm/min
	Spot Size of Laser Beam	0.08 x 0.1mm
	Tilt Alarm	50°±5
	Software Support	MKSLaser APP, LaserGRBL, LightBurn
	System Support	Windows, Mac, Linux
	File Format Support	JPEG, BMP, GIF, PLT, PNG, DXF
	Frame Material	Aluminum
	Materials for Laser Engraving	Wood, Acrylic, China, Fabric, Bamboo, Plastic Board, Leather, Fruit, Bread, etc.
Laser Module	Rated Power	77W
	Input	24V 6A
	Laser Power	22W
Air Pump	Input Voltage	24V
	Input Current	1.5A
	Input Power	36W
	Air Velocity	30L/min
Charger	Input Voltage	AC 100-240V
	Input Current	2.5A
	Output Voltage	24V
	Output Current	6A

5. Package List

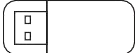
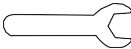
					
Power Adapter *1	USB Cable *1	User Manual *1	Cleaning Brush *1	Wood Board *2	WiFi Antenna *1
					
Metal Plate *1	Goggles *1	Screwdriver *1	Air Pump *1	Laser Module *1	
					
Raiser *4	Raiser for Combination *4	TF Card *1	TF Card Reader *1	Wrench *1	

6. Assembly Guide

Step 1: Installing the WiFi Antenna

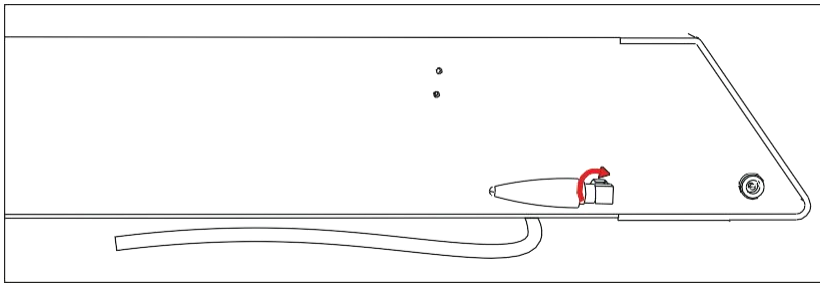

Step 2: Installing Raisers

There are 8 screw holes for mounting raisers. Choose the appropriate holes to mount the raisers based on the tabletop size.

Note: The other 4 raisers can be used in combination to further raise the machine as shown in the second drawing.

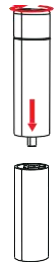
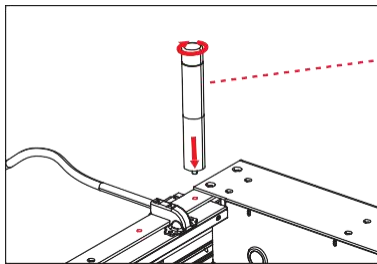
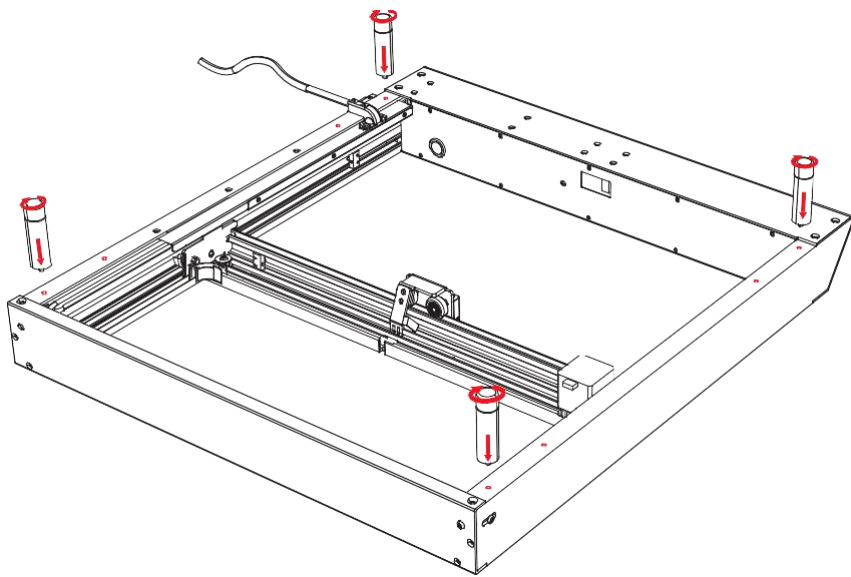

Combination Raisers

Step 3: Installing the Laser Module

- (1) Slide the laser module into the sliding plate. Fix the screws by hand after the laser module is adjusted to the right height.
 - (2) Connect the power cable and exhaust pipe to the laser module according to the corresponding holes.
- Note: A is the power cable of the laser module and B is the exhaust pipe.

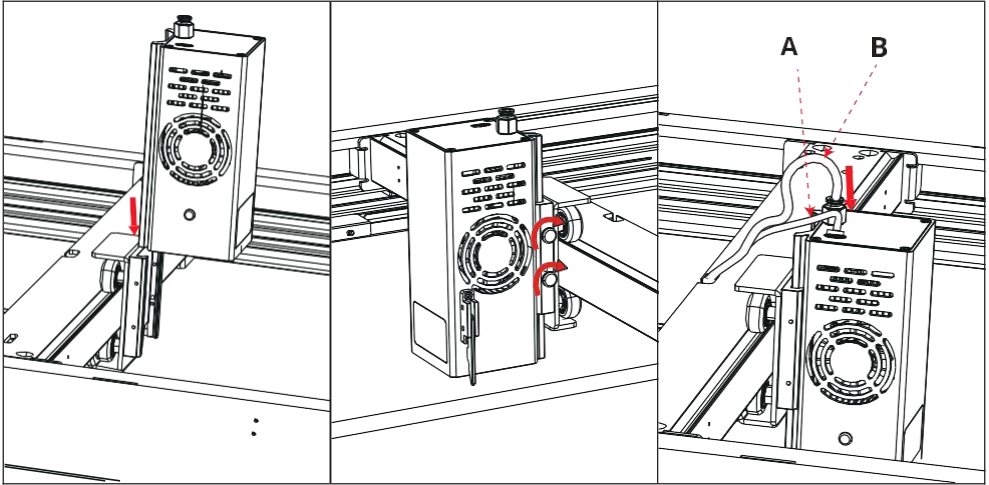

Step 4: Installing the Air Pump

Attach the air pump to the tube of the machine and connect the air pump cable to the air assist interface.

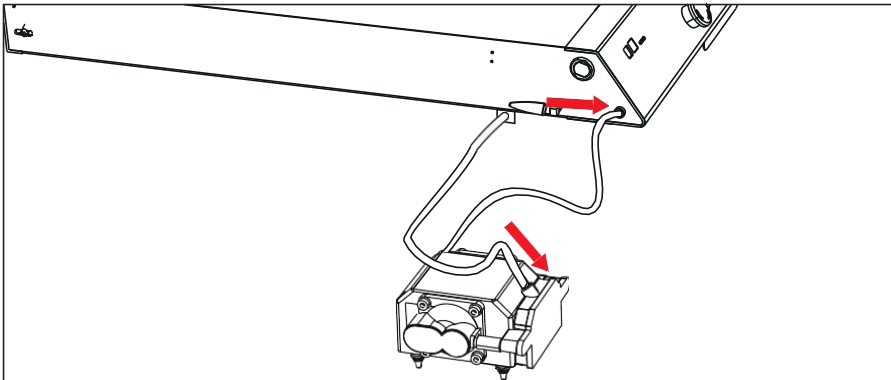

Step 5: Focusing

- (1) Pull down the focusing bar on the laser module.
- (2) Hold the laser module with one hand and loosen the 2 screws to move the laser head.
- (3) Slide the laser head downward slightly till the focusing bar touches the engraving object.
- (4) Tighten the screws to secure the laser module, and then push the bar up into position.

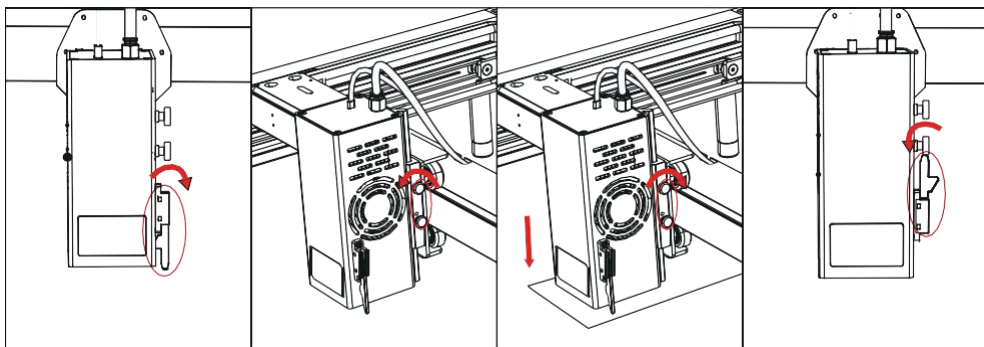

How to Adjust the Belt Tightness

The belts were adjusted at the factory. If the belts become loose after a period of use, they can be adjusted to the proper tightness as follows.

Tightening Y-Axis Belts

- (1) Loosen the screw 1 shown in the line drawing.
- (2) Turn the screw 2 to tighten the belts as the line drawing shows.
- (3) Tighten the screw 1 to secure the belts.

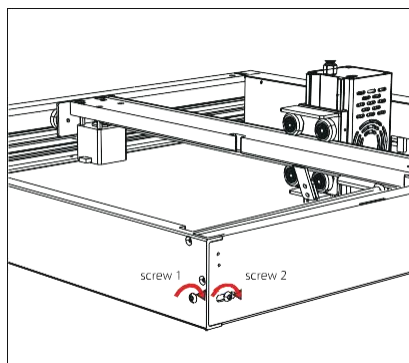
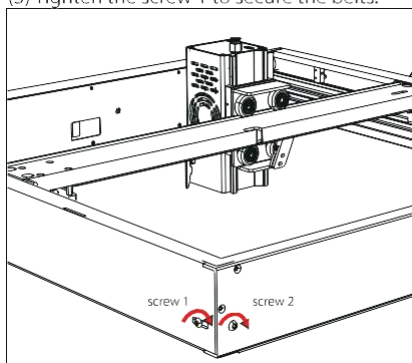

Tightening the Belt of X-Axis Assembly

- (1) Loosen the screw of the device shown in the line drawing and move the device to tighten the belt of the X-axis assembly as the line drawing shows.
- (2) Tighten the screw to secure the belt.

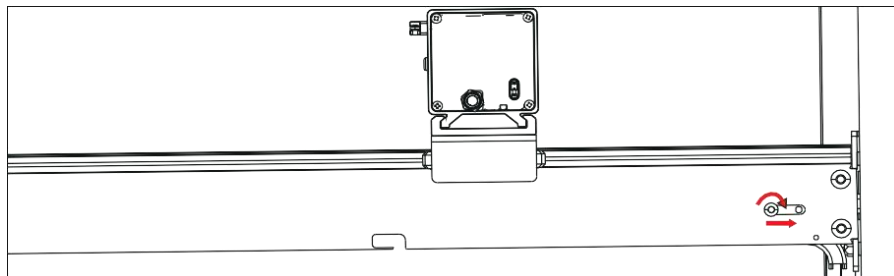

7.Functions & Operations

Parts	Functions / Abnormalities	Operations
Alarm	The alarm will sound when something abnormal occurs.	<ol style="list-style-type: none"> 1. Find out the cause of the alarm. 2. Eliminate this factor. 3. Press the emergency stop button for 3 seconds to reset the machine. Rotate the button back to its original position after pressing it. 4. Follow the software operating instructions to resume work.
Emergency Stop	It stops the machine from working immediately.	Press the button to stop the machine from working and rotate the button clockwise to get the machine back to work.
Flame Sensor	It detects if there is a fire in or around the machine and activates the alarm while also halting the machine's operation in the event of a fire. It is turned on/off via a mechanical switch.	<ol style="list-style-type: none"> 1. Check the environment and avoid placing the machine in direct sunlight. 2. Contact customer service to adjust the sensitivity of the flame sensor.
Air Pump	It assists the machine during operation. Abnormality: It ceases functioning or encounters operational abnormalities	<ol style="list-style-type: none"> 1. Check if the power adapter is connected to a power source. 2. Check if the DC connector of the air pump is properly plugged in. 3. Contact customer service if the problem cannot be solved.
Laser Module	It engraves objects and materials. Abnormality: The laser module fails to work or encounters operational abnormalities.	<ol style="list-style-type: none"> 1. Check if the connection cable of the laser module is properly connected. 2. Check if the main control box is functioning normally. 3. Confirm if the software is correctly installed or configured. 4. Contact customer service if the problem cannot be solved
Limit Switch	It restricts the motor's travel range. Abnormality: The motor continuously moves in the direction of the limit switch, producing a distinct "clunk, clunk" sound.	<ol style="list-style-type: none"> 1. Check if the cable of the limit switch is disconnected. 2. Check if the limit switch plug is installed in place. 3. Check if the limit switch is making contact with the corresponding component. 4. Contact customer service if the problem cannot be solved.

Stepper Motor	It ensures the normal functioning of the laser module.	<ol style="list-style-type: none"> 1. Check if the cables match the required specifications. 2. Confirm that the cables are correctly connected. 3. Check if the control box is properly functioning. 4. Check if the software is properly installed or configured. 5. Contact customer service if the problem cannot be solved.
Flame Sensor Switch	It is used to control the activation and deactivation of flame sensor according to the actual situation	<p>ON state: the flame sensor is in working condition, the machine stops working automatically after checking the flame.</p> <p>OFF state: the flame sensor does not work, you need to pay attention to the fire phenomenon in real time.</p>
Tilt Sensor	If the tilt angle of the machine is greater than 50 ± 5 degrees, the machine will alarm and stop working	Keep the machine at an angle of less than 45 degrees.
Control Methods	<ol style="list-style-type: none"> 1. Control via computer software 2. Control via control panel & TF card 3. Control via mobile App & TF card 	<ol style="list-style-type: none"> 1. Connect to a computer via the USB cable and control via LightBurn or LaserGRBL. 2. Work offline by using the control panel and TF card. 3. Work offline by using MKSlaser and TF card.

8. Driver

Download Methods

1. Download the driver from the link below.
<https://mecpow.com/pages/driver-files>
2. Contact the customer service to get the file of the driver.

Note:

- For Windows users, if you're using a system below Win10, you'll need to install the driver manually. If you're using the Win10 system or above, there is no need to install the driver.
- The driver for Mac users supports OS X 10.9 to OS X 10.15 and OS X 11.0 (Big Sur) and above.
- The driver for Linux users supports 32-bit and 64-bit systems.
- Please turn on the machine and connect it to your computer via the USB cable before starting the driver!

Installation

For Windows Users:

1. Open the downloaded driver.
2. Click "INSTALL".
3. Click "OK" when the driver is installed successfully.

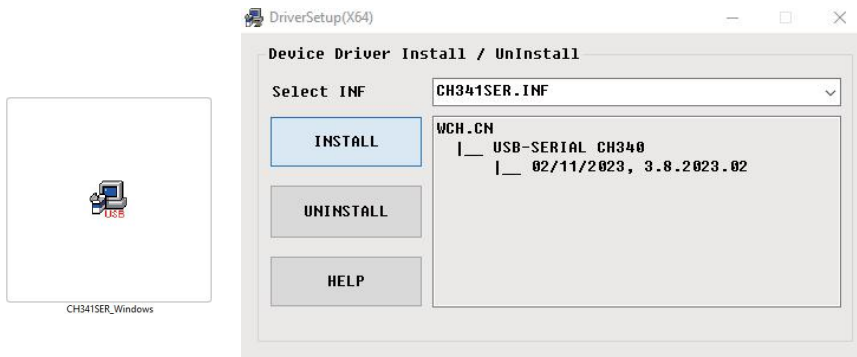

For Mac Users:

1. Open the instructions.
2. Open the downloaded driver and follow the instructions to install it.

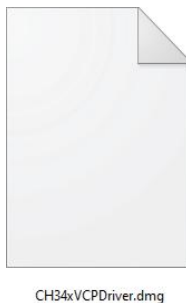

For Linux Users:

1. Open the file - README.
2. Open the file - driver, and follow the "README" to install it



README



9. Control via Computer Software

Connect the engraving machine with the software in real time via the USB cable. During operation, you can start or stop the engraving machine through the control panel.

LaserGRBL

It's a free open-source software that supports Windows computers. Download it from: <http://lasergrbl.com/download/>

1. Install it.
2. Open the software. Select "COM3" and click "Connect".

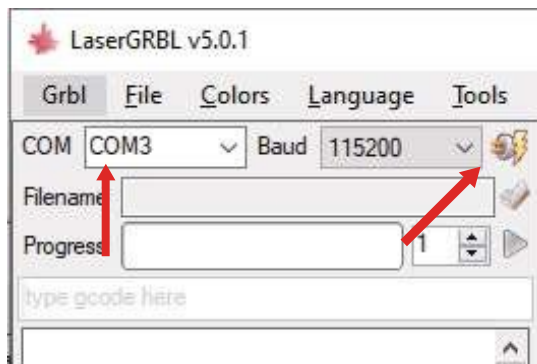

3. Click "Open File" to select the engraving file.

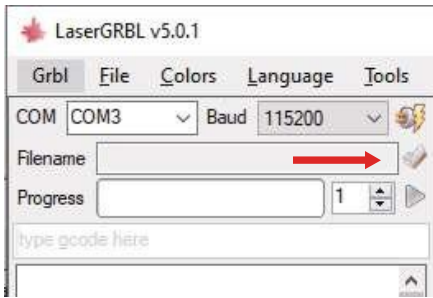

4. Select the engraving mode and click "Next".



5. Select the operating parameters for laser engraving or cutting. (M3 is for constant power carving, and M4 is for variable power. Please check section 10 for recommended operating parameters for engraving or cutting different materials.)



6. Enter "M7" in the command box and press Enter to start the air pump. To stop the air pump, enter "M9" in the same box and press Enter.

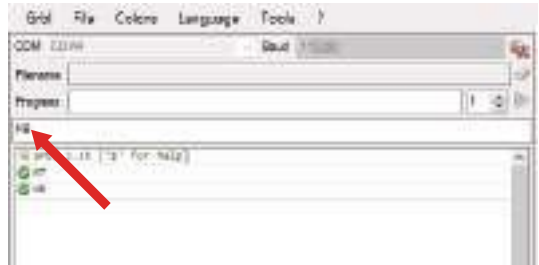

7. Click "Framing" to preview the engraving range and adjust the engraving position.



8. Click "Run Program" to start engraving



LightBurn

It's a paid professional software that supports MAC, Linux and Windows computers. Download it from: <https://lightburnsoftware.com/pages/trial-version-try-before-you-buy>.

- 1. Install it.
- 2. Open the software and click "Find My Laser".



- 3. Select your device and click "Add Device".

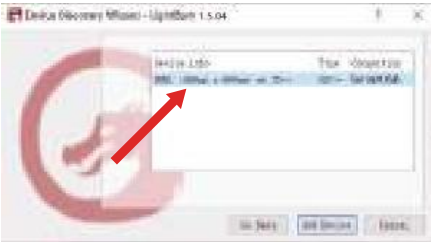

- 4. Name your device and enter the X-axis and Y-axis lengths, then click "Next".

Name: Mecpow X4
 X Axis Length: 410mm
 Y-Axis Length: 400mm

- 5. Select "Front Left" as the origin of your laser and click "Next".



6. Click "Finish".



7. Select Mecpow X4 and click "OK".

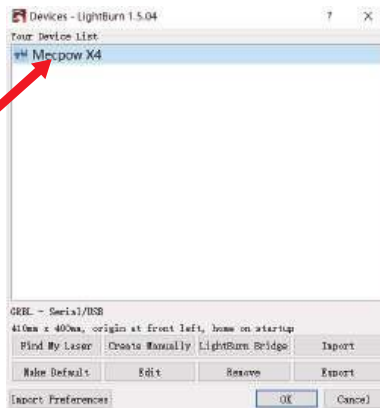

8. Click "Edit" - "Settings" and set the unit to "mm/min", then click "OK".



9. Click "Edit" - "Device Settings" and select "M7" under "Air Assist" to allow the air pump to run in sync with the machine.

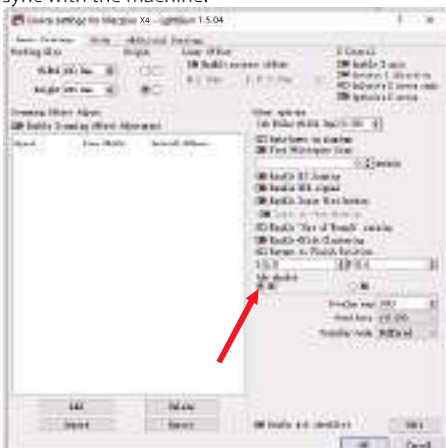

10. Select "Current Position" in the "Start From" section, and then select the circle in the lower left corner in the "Job Origin" section.

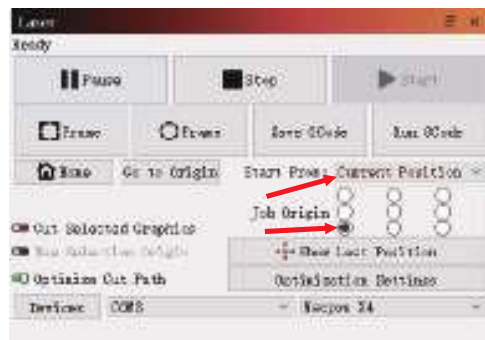

11. Click "File" - "Import" to import the engraving file.



12. You can modify the engraving size on the top of the interface after importing the file.

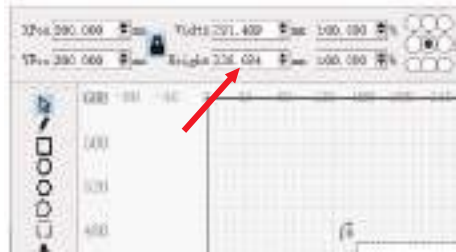

13. Select the engraving mode and set the operating parameters for laser engraving or cutting. (Recommended operating parameters for engraving or cutting different materials are listed in the next section.)



14. Click "Frame" to preview the engraving range and adjust the engraving position, then click "Start" to start engraving.

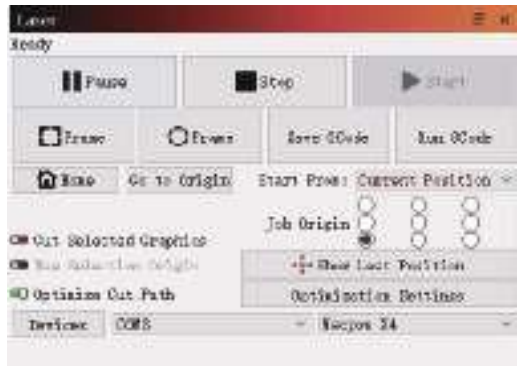

10. Control via Control Panel & TF Card

1. Prepare a LightBurn G-code file for engraving or cutting and save it in the root directory of the TF card. Insert the TF card into the engraving machine. The indicator on the control panel lights up, indicating that the file is loaded successfully.

Note:

- The TF card only supports the FAT32 format.
- The engraving machine reads the latest modified file in the root directory of the TF card by default when there is more than one file in it.
- The engraver can only recognize NC and GC files with English names.
- The engraver can recognize NC and GC files saved with LightBurn. However, NC and GC files saved with LaserGRBL can only be recognized by the engraver after being converted with MKSLaser. MKSLaser can be obtained from the attached TF card or Mecpow.com.

2. Press the "Frame" key, and the machine will enter the preview mode. The laser module will move along the X/Y axis to frame the target working area. You can then manually adjust the engraved object to the proper position or use the arrow keys on the control panel to adjust the laser module to the proper position.

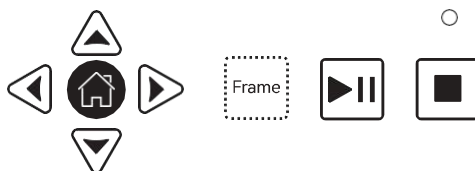

3. Press the "Start/Pause" key to start engraving/cutting. If you need to pause while the engraver is working, press the "Start/Pause" key and then press it again to continue engraving/cutting. If you need to terminate the task, press the "Stop" key. When the engraving/cutting is complete, the laser module will move back to the starting position. When not in working condition, press the "Start/Pause" key, and the engraver will repeat the last engraving/cutting task, which is suitable for mass production.

Note:

- The "Start/Pause" and "Stop" keys have higher control access to the engraver than the computer software and the mobile App, which means engraving/cutting tasks issued by your computer or mobile phone can be started, paused and terminated directly through the control panel.
- If an engraving/cutting task issued by the computer or mobile phone is terminated, it can only be restarted by the computer or mobile phone.
- The "Frame" and arrow keys do not work during the engraving/cutting process.

11. Control via Mobile App & TF Card

MKSLaser is a free mobile application that supports Android and iOS devices.

App Download

Scan the QR code and download it.



iOS



Android

Wi-Fi Connection

1. Enable the Wi-Fi function of your phone and connect the Wi-Fi "Mecpow_*****".

Wi-Fi Name: Mecpow_*****

Wi-Fi Password: 12345678

Note:

- The "*****" in the Wi-Fi name is a random combination of numbers. It varies by machine.
- To ensure the stability of the Wi-Fi signal, it is recommended to connect your phone to the Wi-Fi of the engraving machine before inserting the TF card.
- The app needs to be used with the TF card. The uploading of the engraving file will fail if the TF card has not been inserted.

2. Open the MKSLaser app.

3. Click on the  icon.



4. Enter the IP address: 192.168.4.1

5. Click on "Connect".



6. When "Connect" turns to "Disconnect", it means the Wi-Fi connection is successful.



For detailed usage of the MKSLaser app, please refer to the information in the TF card or download the user manual by visiting the link below or scanning the QR code below.

<https://mecpow.com/pages/download-center>



12. Recommended Operating Parameters

Mecpow X4 (22W)				
Mode	Materials	Power (%)	Speed (mm/min)	Note
Engraving	Wood Board	20	3000	
	Bamboo	50	3000	
	Resin	13	1000	
	Leather	20	3000	
	Glass	50	1000	The surface needs to be painted.
	Ceramics	80	1000	The surface needs to be applied with heat transfer paper.
	Acrylic	50	3000	The surface needs to be painted.
	Stainless Steel	80	600	
	Rubber	50	3000	
	Carton	15	3000	
Cutting	8mm Thick Board	100	200	
	9mm Thick Board	100	130	
	10mm Thick Board	100	75	
	0.2mm Paper	80	3000	
	2mm Leather	80	300	
	5mm Acrylic	100	100	

13. Troubleshooting

1. The machine doesn't respond when powered on.

A. Check if the machine is properly plugged into the socket and turned on.

2. The machine fails to connect to the computer.

A. Check if the USB cable is properly connected to both the computer and the machine.

B. Install the driver as instructed, and make sure the computer recognizes the device as a serial port.

C. Disconnect the USB cable and power supply, wait for 5 seconds, and then reconnect.

3. The engraving is too light or non-existent.

A. Make sure the machine is accurately focused according to the manual.

B. Adjust the engraving speed. If it engraves too fast, it may not have enough time to burn the object.

C. The image is too shallow. Imported images need to be clear, with fine lines, and not too light in color, as this will directly affect the engraving effect.

D. Ensure the object being engraved is placed flat and parallel to the machine to avoid focusing issues.

4.The offline engraving process stops unexpectedly.

- A. Verify if the emergency stop button has been accidentally pressed. If pressed, turn it to the right to release.
- B. Check if the switch has been accidentally toggled off. If so, turn it back on.
- C. If all the above appear to be normal, please contact customer service.

5.The software stops running abruptly during engraving.

- A. Check whether the USB cable is loose.
- B. Confirm that the software is installed correctly and the configuration files are accurate.
- C. Ensure the engraving file is working properly.
- D. If all the above appear to be normal, please contact customer service.

6.The machine moves correctly, but the laser remains inactive.

- A. Validate that the laser module cable is correctly connected.
- B. Check if there's any slight noise coming from the laser module's fan.
- C. If all the above appear to be normal, please contact customer service.

For more questions and answers, please refer to the link below or scan the QR code below.

<https://mecpow.com/pages/faq>

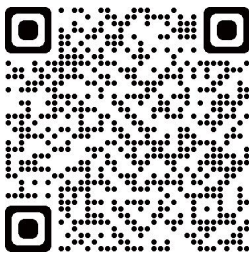

14. Compliance Statement



This product is in compliance with the standards of the European Community.



This product complies with the Restriction of Hazardous Substances in Electrical and Electronic Equipment (RoHS) EU rules restricting the use of hazardous substances in electrical and electronic equipment to protect the environment and public health.



This device complies with Part 15 of the FCC Rules Operation is subject to the following two conditions: (1) this device may not cause harmful interference, and (2) this device must accept any interference received, including interference that may cause undesired operation.



The laser warning sign is used to alert users and visitors if there is a risk of being exposed to a naked laser beam. Exposure to certain lasers can cause eye or optic damage and skin burns.



This symbol indicates that the product is capable of being recycled.

INHALTE

1. Vorwort.....	22
2. Sicherheitserklärung.....	22
3. Diagramm.....	23
4. Spezifikationen.....	25
5. Lieferumfang.....	25
6. Montageanleitung.....	26
7. Funktionen & Betrieb.....	29
8. Treiber.....	31
9. Steuerung über Computersoftware.....	32
10. Steuerung über Bedienfeld und TF-Karte.....	37
11. Steuerung über Mobile App & TF-Karte.....	38
12. Empfohlene Betriebsparameter.....	39
13. Problembewältigung.....	40
14. Konformitätserklärung.....	41

1. Vorwort

Sehr geehrter Kunde,

Vielen Dank, dass Sie sich für unser Lasergravurgerät entschieden haben. Dieses Gerät ist ein High-Tech-Produkt, das Licht, Maschinen und Elektrizität vereint. Damit Sie das Gerät besser nutzen und warten können, lesen Sie bitte das Benutzerhandbuch sorgfältig durch und befolgen Sie die darin beschriebenen Schritte.

Haftungsausschluss

Jegliche Verluste, die durch unsachgemäßen Gebrauch oder Nichtbeachtung der Schritte im Benutzerhandbuch verursacht werden, gehen zu Lasten der Person. Die endgültige Interpretation des Benutzerhandbuchs obliegt unserem

und wir behalten uns das Recht vor, alle Informationen, Daten, technischen Details usw. in diesem Handbuch zu ändern.

2. Sicherheitserklärung

Sicherheitsvorkehrungen

* Die Laserbearbeitung kann risikoreich sein, und Benutzer sollten sorgfältig prüfen, ob das zu bearbeitende Objekt für die Laserarbeit geeignet ist.

* Das zu bearbeitende Objekt und die Emissionen müssen den örtlichen Gesetzen und Vorschriften entsprechen.

* Dieses Gerät verwendet einen Laser der Klasse IV (leistungsstarke Laserstrahlung), der die folgende Situationen:

(1) Entzündung von brennbaren Materialien in der Umgebung;

(2) Bei der Laserbearbeitung können je nach dem zu bearbeitenden Objekt andere Strahlung sowie giftige und schädliche Gase entstehen;

(3) Die direkte Einwirkung von Laserstrahlung kann den menschlichen Körper schädigen. Am Arbeitsplatz müssen Feuerlöschgeräte vorhanden sein, und brennbare und explosive Materialien dürfen nicht um die Werkbank oder Maschine herum gestapelt werden. Außerdem muss für eine gute Belüftung gesorgt werden.

* Die Umgebung, in der das Gerät steht, sollte trocken und frei von Verschmutzung, Vibrationen, starker Elektrizität, starkem Magnetismus und anderen Störungen sein. Die Umgebungstemperatur sollte 5-30°C und die Luftfeuchtigkeit 35-65%RH betragen.

* Die Betriebsspannung der Maschine ist AC100-240V.

* Während des Betriebs der Maschine muss diese durchgehend überwacht werden. Vor der Abreise muss der Strom abgeschaltet werden, um unvorhergesehene Probleme zu vermeiden. Wenn eine abnormale Situation auftritt, schalten Sie bitte sofort den Strom ab und kümmern Sie sich darum!

* Es ist strengstens untersagt, reflektierende oder diffuse Gegenstände in das Gerät zu stellen, die für den Betrieb nicht relevant sind, um Laserreflexionen auf den menschlichen Körper oder brennbare Materialien zu vermeiden.

* Das Gerät sollte von elektrischen Geräten ferngehalten werden, die empfindlich auf elektromagnetische Störungen reagieren und diese verursachen können.

* Das Zerlegen des Lasergravierers durch Nichtfachleute ist strengstens untersagt, da im Inneren des Geräts Gefahren wie Hochspannung bestehen können.



Warnung

1. Die Lasergravurmaschine kann Laserlicht erzeugen. Es ist strengstens untersagt, lebende Organismen unter den Laserstrahl zu bringen (der Anschluss ist mit einem gelben Warnschild gekennzeichnet). 2. Lichtempfindlichen Patienten ist es untersagt, das Lasergerät zu benutzen oder sich ihm zu nähern. 3. Bei der Verwendung der Lasergravurmaschine müssen der Bediener und alle Personen in der Nähe der Maschine eine Laserschutzbrille tragen. Bedienen Sie das Lasergerät nicht ohne Laserschutzbrille. Unser Gerät wird mit einer Laserschutzbrille geliefert. Wenn Sie eine zusätzliche Schutzbrille kaufen möchten, sollte diese einen Wellenlängenschutz zwischen 400-445nm (+5nm) bieten, einen Außendurchmesser von +5 haben und mindestens der Stufe L5 entsprechen.

4. Wenn das Lasergravurgerät in Betrieb ist, muss der Benutzer sehr aufmerksam sein und darf es nicht unbeaufsichtigt lassen, um eine Entzündung des gravierten Materials zu vermeiden. Stellen Sie das Gerät an einem feuerfesten Ort auf und sorgen Sie für eine gute Belüftung. Es wird empfohlen, ein Feuerlöschgerät in der Nähe zu haben, für Notfälle.

5. Stellen Sie sicher, dass sich in der Nähe des Lasergraviergeräts keine brennbaren Materialien befinden. Wir empfehlen, einen Wabenarbeitstisch unter die Maschine zu stellen.

6. Achten Sie beim Betrieb des Lasergravierers darauf, dass genügend Platz um ihn herum vorhanden ist. Beim Gravieren bestimmter Materialien kann Rauch entstehen, der über ein spezielles Abluftsystem abgesaugt werden sollte.

7. Berühren Sie weder den Laserstrahl noch das zu bearbeitende Objekt, während das Gerät in Betrieb ist, da dies zu schweren Verletzungen oder Strahlenreflexionen führen kann. Vermeiden Sie außerdem

den Kühler zu berühren, da er durch die Arbeit des Lasergravierers oder den kürzlichen Stillstand heiß sein kann.

8. Kinder oder Jugendliche (vor allem unter 14 Jahren) dürfen das Lasergraviergerät nicht allein benutzen und sollten jederzeit von einem Erwachsenen beaufsichtigt werden.

9. Die Betriebstemperatur des Geräts beträgt 41°F-86°F (5°C-30°C).

10. Schalten Sie das Gerät aus, wenn es nicht benutzt wird, um Missbrauch durch Dritte zu vermeiden.

11. Bei der Lasergravur besteht Brandgefahr. Wenn das Lasergraviergerät in Betrieb ist, muss es von einem geschulten Bediener beaufsichtigt werden, der mit einem Feuerlöscher umgehen kann, um alle Unfälle, die passieren können zu verhindern.

12. Unsere Lasergravurmaschine ist mit einem eingebauten Flammensensor ausgestattet, um die Sicherheit unserer Geräte zu maximieren. Bitte beachten Sie jedoch, dass keine schriftliche oder stillschweigende Garantie gegeben wird bezüglich der Verfügbarkeit oder Funktionalität des Flammensensors.

Wartung

Empfehlungen:

Schalten Sie das Gerät nach 4 Stunden Gravieren und nach 1 Stunde Schneiden für 10 Minuten aus.

Das Lasermodul ist ein Verschleißteil.

3. Diagramm

1. Rechte Y-Achse
2. Hintere X-Achse
3. Linke Y-Achse
4. X-Achsen-Baugruppe
5. Vorrichtung zum Einstellen des X-Achsen-Gurtes
6. Vordere X-Achse
7. Luftpumpe
8. Steuerungs-Box

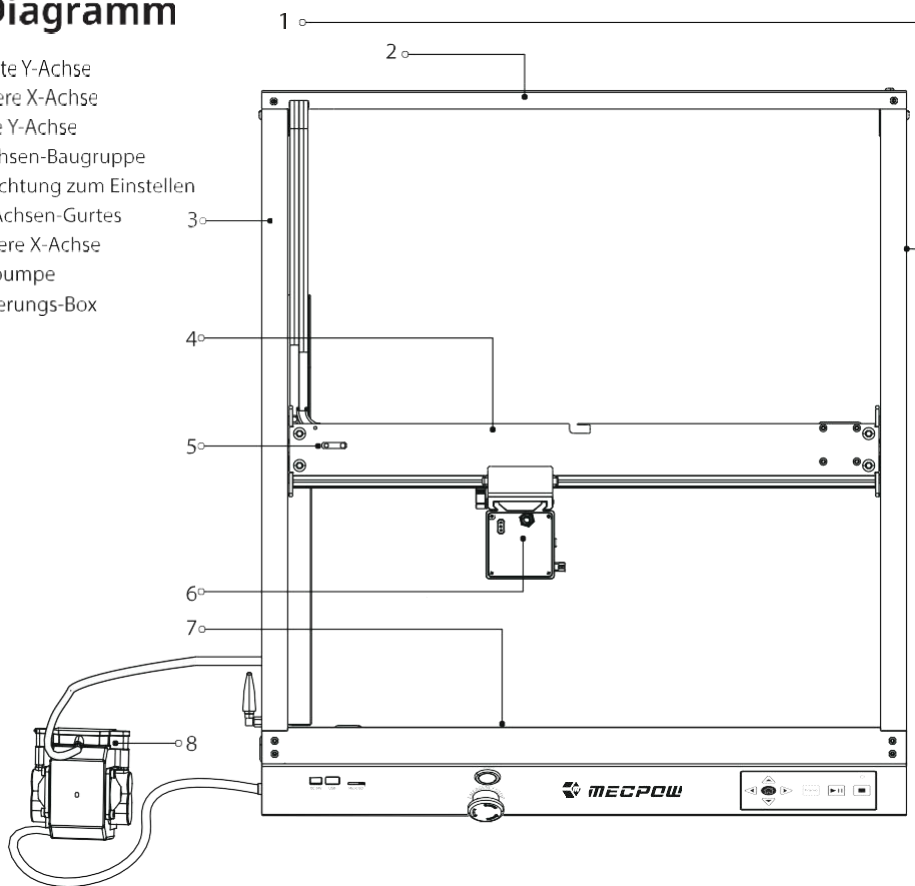

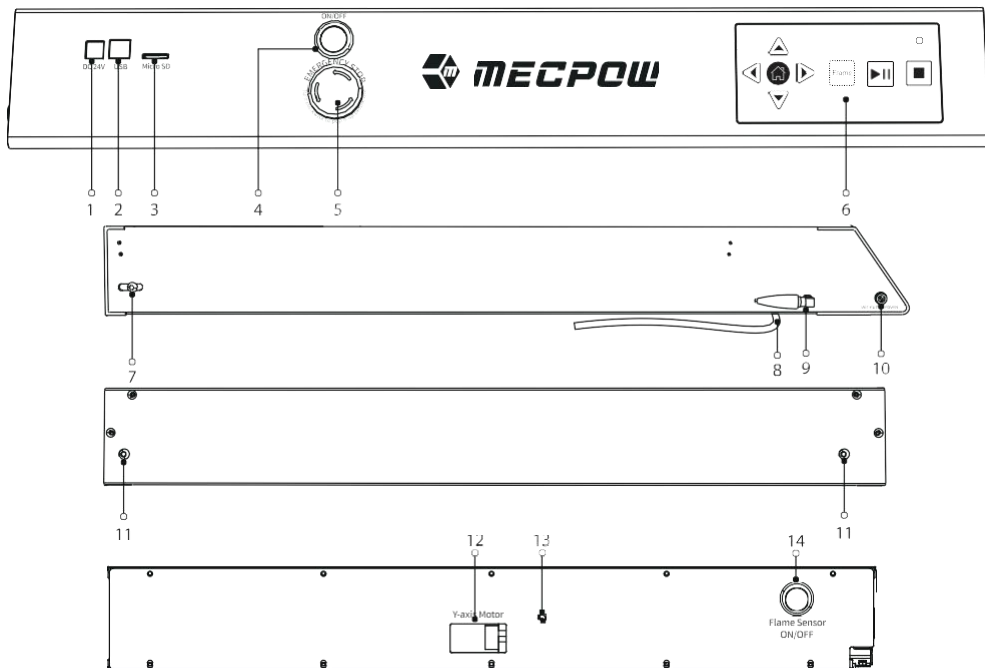

- | | | |
|-------------------------|---|--|
| 1. Gleichstromanschluss | 6. Bedienfeld | 10. Air-Assist-Schnittstelle |
| 2. USB-Anschluss | 7. Schraube zur Befestigung des Y-Achsgurts | 11. Schrauben zum Einstellen des Y-Achsen-Gurtes |
| 3. Micro-SD-Anschluss | 8. Schlauch für Luftpumpe | 12. Y-Achse Motor |
| 4. Ein-/Ausschalter | 9. WiFi-Antenne | 13. Flammensensor |
| 5. Not-Aus-Taste | | 14. Flammensensor-Schalter |











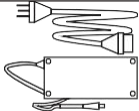
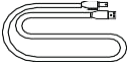

Einführung in das Bedienfeld

Schlüssel-Symbole	Name der Taste	Taste Funktion
	Pfeil-Tasten	Drücken Sie kurz eine der Tasten, und das Lasermodul bewegt sich 1 mm in die entsprechende Richtung. Wenn Sie die Taste 3 Sekunden oder länger drücken, bewegt sich das Lasermodul weiter, bis Sie die Taste loslassen oder das Lasermodul den Endschalter erreicht.
	Startseite	Drücken Sie diese Taste, um das Lasermodul in die Ausgangsposition zurückzubringen.
	Taste Patrouille	Drücken Sie diese Taste, und das Lasermodul fährt den Arbeitsbereich der ersten G-Code-Datei auf der TF-Karte ab.
	Start/Pause-Taste	Drücken Sie diese Taste, um die Gravur zu starten/pausieren.
	Stopp-Taste	Drücken Sie diese Taste, um die Gravur zu beenden.
	TF-Karten-Anzeige	Leuchtet auf, wenn die TF-Karte erkannt und gelesen wird.

4. Spezifikationen

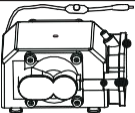
Modell	X4	
Grundlegende Angaben	Produktgröße	685x620x190mm
	Paketgröße	715 x 645x145mm
	Gewicht	10.6kg
	Eingangsspannung	DC 24V
	Nennleistung	144W
	Max. Gravurfläche	410x400mm
	Max. Graviergeschwindigkeit	22000mm/min
	Spotgröße des Laserstrahls	0,08x0,1mm
	Kipp-Alarm	50°±5
	Software-Support	MKSLaser APP, LaserGRBL, LightBurn
	Unterstützte Betriebssysteme	Windows, Mac / Linux
	Unterstützte Dateiformate	JPEG, BMP, GIF, PLT, PNG, DXF
	Rahmen-Material	Aluminiumlegierung
	Materialien für die Lasergravur	Holz, Acryl, China, Stoff, Bambus, Kunststoffbrett, Leder, Obst, Brot, etc.
Laser-Modul	Nennleistung	77W
	Eingang	24V 6A
	Laserleistung	22W
Luftpumpe	Eingangsspannung	24V
	Eingangsstrom	1,5A
	Eingangsleistung	36W
	Luftgeschwindigkeit	30L/min
Ladegerät	Eingangsspannung	AC 100-240V
	Eingangsstrom	2,5A
	Ausgangsspannung	24V
	Ausgangsstrom	6A

5. Lieferumfang

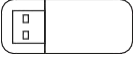
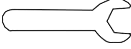
					
Netzadapter *1	USB-Kabel *1			Holz-Brett *2	WiFi-Antenne *1
					
Metallplatte *1	Schutzbrille *1		Luftpumpe*1	Laser-Modul *1	
					
Erhöher*4	Erhöher für Kombinationen*4	TF-Karte *1	TF-Kartenleser *1	Schraubenschlüssel *1	