



PHOENIX
TESTLAB

Königswinkel 10
32825 Blomberg, Germany
Phone: +49 (0) 52 35 / 95 00-0
Fax: +49 (0) 52 35 / 95 00-10
office@phoenix-testlab.de
www.phoenix-testlab.de

Test Report

Report Number:

F200562E1 2nd version

Equipment under Test (EUT):

**Oceanographic radar
WERA model 4.0**

Applicant:

Helzel Messtechnik GmbH

Manufacturer:

Helzel Messtechnik GmbH



Deutsche
Akkreditierungsstelle
D-PL-17186-01-01
D-PL-17186-01-02
D-PL-17186-01-03

REFERENCES

- [1] **FCC CFR 47 Part 90:** Private Land Mobile Radio Services
- [2] **FCC CFR 47 Part 2:** Frequency Allocations and Radio Treaty Matters; General Rules and Regulations
- [3] **ANSI C63.26-2015:** American National Standard for Methods of Measurement of Radio-Noise Emissions from Low-Voltage Electrical and Electronic Equipment in the Range of 9 kHz to 40 GHz

TEST RESULT

The requirements of the tests performed as shown in the overview (clause 4) were fulfilled by the equipment under test.

The complete test results are presented in the following.

Tested and written by:	Wolfgang KASALOWSKY <small>Name</small>	<i>W. Kasalowsky</i> <small>Signature</small>	05.10.2020 <small>Date</small>
Reviewed and approved by:	Bernd STEINER <small>Name</small>	<i>B. Steiner</i> <small>Signature</small>	05.10.2020 <small>Date</small>

This test report is only valid in its original form.

Any reproduction of its contents in extracts without written permission of the accredited test laboratory PHOENIX TESTLAB GmbH is prohibited.

The test results herein refer only to the tested sample. PHOENIX TESTLAB GmbH is not responsible for any generalizations or conclusions drawn from these test results concerning further samples. Any modification of the tested samples is prohibited and leads to the invalidity of this test report. Each page necessarily contains the PHOENIX TESTLAB Logo and the TEST REPORT NUMBER.

Contents:	Page
1 Identification.....	4
1.1 Applicant.....	4
1.2 Manufacturer	4
1.3 Test laboratory.....	4
1.4 EUT (Equipment Under Test).....	5
1.5 Technical data of equipment	6
1.6 Dates	6
2 Operational states.....	7
3 Additional information	7
4 Overview.....	7
5 Test results	8
5.1 Frequency band.....	8
5.1.1 Method of measurement	8
5.1.2 Test result.....	9
5.2 Transmitter output power.....	13
5.2.1 Method of measurement	13
5.2.2 Test result.....	13
5.3 Type of emission	14
5.4 Band edge compliance	15
5.4.1 Method of measurement	15
5.4.2 Test Results	16
5.5 Spurious emissions (conducted)	20
5.5.1 Method of measurement	20
5.5.1.1 Spurious emissions.....	21
5.6 Spurious emissions (radiated).....	28
5.6.1 Method of measurement	28
5.6.2 Radiated emission measurement.....	31
5.7 Frequency Stability	36
5.7.1 Method of measurement	36
5.7.1.1 Test results.....	36
6 Test equipment used for tests	40
7 Test site validation	40
8 Report history	41
9 List of annexes.....	41

1 Identification

1.1 Applicant

Name:	HELZEL Messtechnik GmbH
Address:	Carl-Benz-Strasse 9 24568 Kaltenkirchen
Country:	Germany
Name for contact purposes:	Mr. Thomas HELZEL
Phone:	+49 4191 95200
Fax:	+49 4191 952040
eMail Address:	helzel@helzel.com
Applicant represented during the test by the following person:	None

1.2 Manufacturer

Name:	HELZEL Messtechnik GmbH
Address:	Carl-Benz-Strasse 9 24568 Kaltenkirchen
Country:	Germany
Name for contact purposes:	Mr. Thomas HELZEL
Phone:	+49 4191 95200
Fax:	+49 4191 952040
eMail Address:	helzel@helzel.com
Manufacturer represented during the test by the following person:	None

1.3 Test laboratory

The tests were carried out at: **PHOENIX TESTLAB GmbH**
Königswinkel 10
32825 Blomberg
Germany

Accredited by Deutsche Akkreditierungsstelle GmbH (DAKKS) in compliance with DIN EN ISO/IEC 17025 under Reg. No. D-PL-17186-01-05 and D-PL-17186-01-06, FCC Test Firm Accreditation designation number DE0004, FCC Test Firm Registration Number 469623, CAB Identifier DE0003 and ISED# 3469A.

1.4 EUT (Equipment Under Test)

Test object: *	Oceanographic radar		
Type: *	WERA model 4.0		
FCC ID: *	2AV3S-WERA		
Serial number: * HW version *:	Unit	Serial number *	HW version *
	User interface PC	3095364s002	-
	Frequency control rack	FCR -1948-134	V4.4
	Receiver rack	RER-2011-198	V3.17
	Receiver input filter	RIN-2014-421	V12.0
	Receiver input filter	RIN-2014-422	V12.0
	Power amplifier rack	PAR-1902-94	V1.6
Firmware version *:	V3.3.2		

* declared by the applicant.

Note: PHOENIX TESTLAB GmbH does not take samples. The samples used for tests are provided exclusively by the applicant.

1.5 Technical data of equipment

Operating frequency bands: *	5.250 MHz to 5.275 MHz 13.450 MHz to 13.550 MHz 16.100 MHz to 16.200 MHz		
Modulation: *	Radar: FMCW ID: ASK		
Type of emission: *	During radar mode: NXN While transmitting the ID: A1A		
Rated Power: *	45 dBm		
Supply Voltage: *	$U_{nom} = 120 V_{AC} / 60 \text{ Hz}$	$U_{min} = 102 V_{AC} / 60 \text{ Hz}$	$U_{max} = 138 V_{AC} / 60 \text{ Hz}$
	$U_{nom} = 240 V_{AC} / 60 \text{ Hz}$	$U_{min} = 204 V_{AC} / 60 \text{ Hz}$	$U_{max} = 276 V_{AC} / 60 \text{ Hz}$
Temperature range: *	+10°C to + 30°C		
Highest internal clock frequency: *	Max. 3.2 GHz		

* declared by the applicant.

Ancillary devices:	
Monitor	PHILIPS MODEL ID:221S8LDAB/00, S/N: ZV0A1848025834
Keyboard	CHERRY Modell RS 6000 USB 0N, S/N: 1205787
Mouse	M/N: M-U0026, P/N: 810-003656, S/N: 1849HS022T68

The following external I/O cables were used:

Identification	Connector		Length*
	EUT	Ancillary	
Ethernet	RJ45	WAN	2 m *
AC in	Rubber connector	AC mains	2 m *
TX antenna	N connector	Attenuator, Spectrum Analyser / RF power meter / Dummy Load	1 m *

*: Length during the test if no other specified.

1.6 Dates

Date of receipt of test sample:	05.05.2020
Start of test:	07.05.2020
End of test:	10.08.2020

2 Operational states

The EUT is an oceanographic radar operating in FMCW mode.

The transmitted signal is a sine wave sweep over the allocated band with a sweep rate of typical 2 to 4 Hz. It is a CW signal, which is not gated or pulsed.

3 times per hour the system transmits a Morse code for identification purpose. For this short period (1 min) the signal is amplitude modulated.

The modes used for the tests of this report were set by an internal user interface.

All tests were carried out with an unmodified sample.

To reduce the stress of the internal power supplies the applicant recommends supplying the EUT with 240 V AC (Voltage between two phases with 180 degrees phase shift) if possible.

During the tests the EUT was powered with 120 V AC or 240 V AC. Please refer to the test cases.

The bandwidth reduction was set to the parameter 7000m (21.4 kHz) for the 5.250 MHz to 5.275 MHz band and to parameter 1650m (90.0 kHz) for the 13.45 MHz to 13.55 MHz and 16.1 MHz to 16.2 MHz band.

As stated by the applicant the EUT must be used in climatized rooms only. Therefore the frequency stability was tested in the temperature range 10 °C to 30 °C.

3 Additional information

None

4 Overview

Application	FCC CFR 47	Status	Refer page
Frequency bands	90.103	Passed	8
Transmitter output power (conducted)	90.103	Passed	13.
Type of emission	90.207	Passed *	14
Occupied bandwidth *	90.209	Not applicable *	-
Spectrum emission mask *	90.210	Not applicable *	-
Spurious emissions	90.210	Passed	15
Frequency stability	90.213	Passed	36

* Inquiry to FCC on 27.05.2020

5 Test results

5.1 Frequency band

5.1.1 Method of measurement

Test setup:

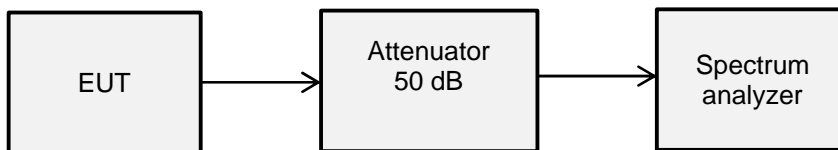

The following spectrum analyser settings were used:

- Span: 50 kHz / 200 kHz
- Resolution bandwidth: 300 Hz / 1 kHz
- Video bandwidth: 1 kHz / 3 kHz
- Mode: FFT
- Sweep time: 1s (Sweep mode), auto (ID)
- Detector function: Peak
- Trace mode: Max hold

Via the internal user interface the EUT was set to

1. Sweep mode: sweep over the band.
2. ID mode: Transmit its ID in Morse mode.

Supply Voltage of EUT: 240 V

5.1.2 Test result

Ambient temperature	23 °C	Relative humidity	25 %
---------------------	-------	-------------------	------

Frequency band: 5.250 MHz to 5.275 MHz; EUT in sweep mode

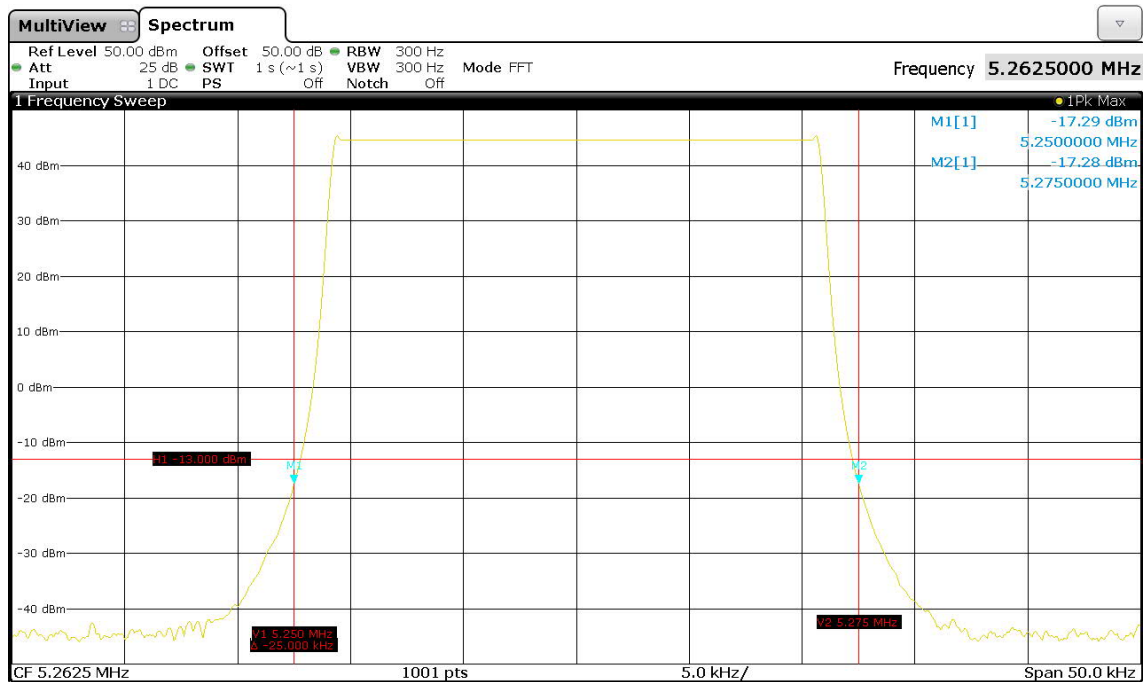

Frequency band: 5.250 MHz to 5.275 MHz; EUT is ID mode

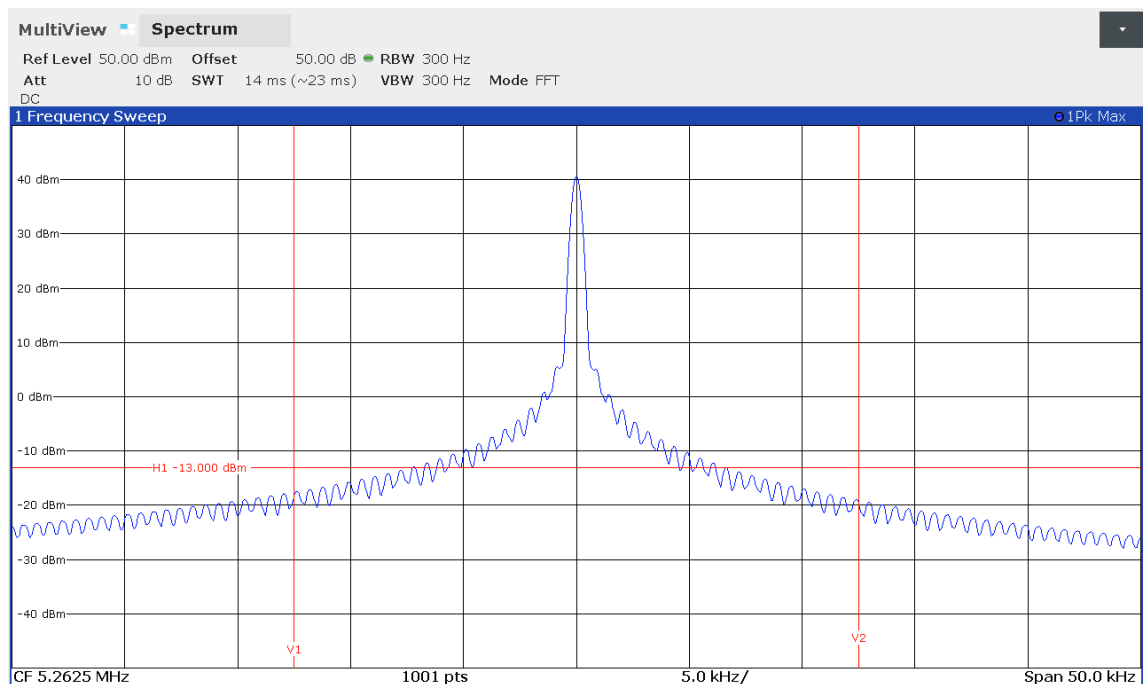

Frequency band: 13.450 MHz to 13.550 MHz; EUT in sweep mode

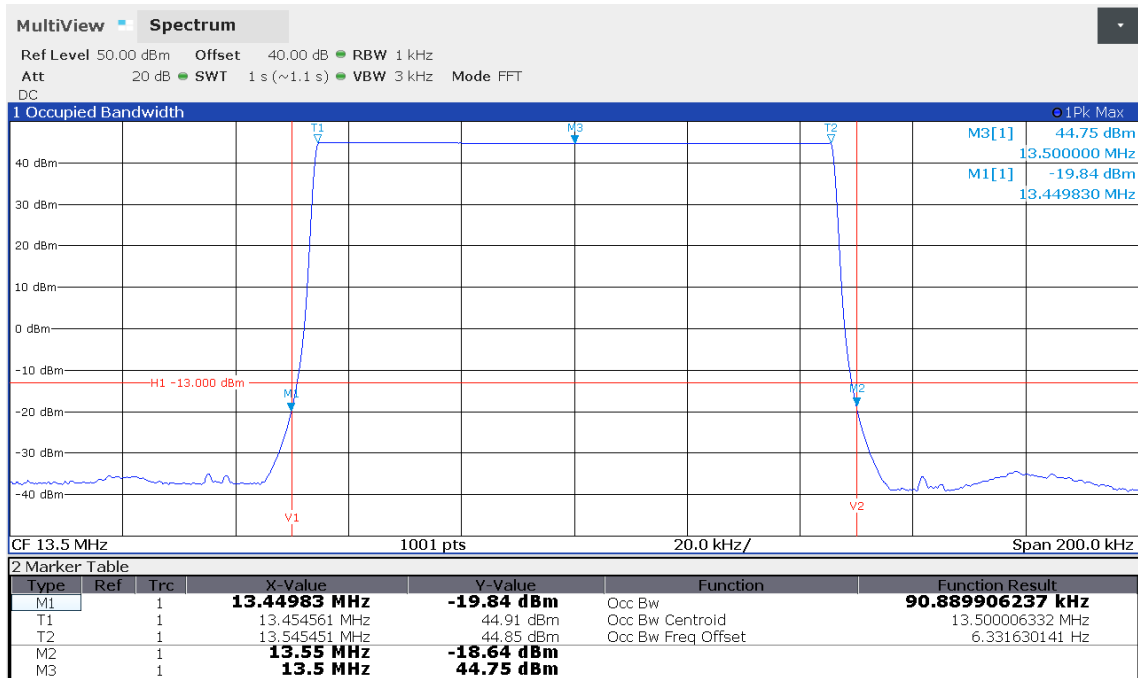

Frequency band: 13.450 MHz to 13.550 MHz; EUT is in ID mode

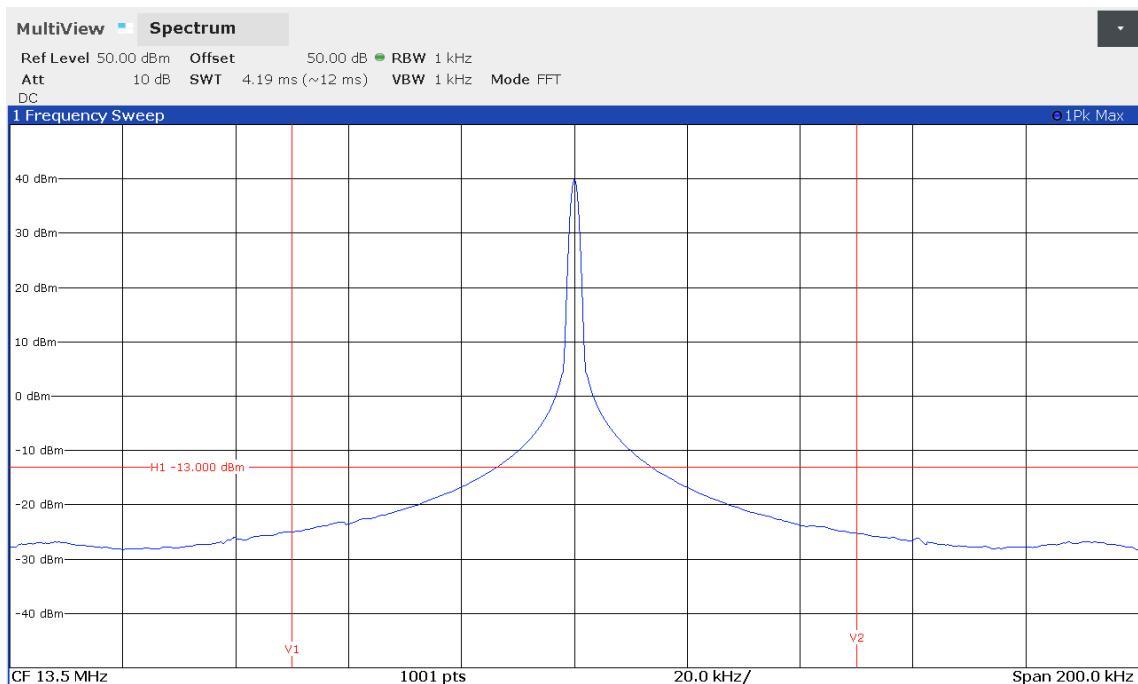

Frequency band: 16.100 MHz to 16.200 MHz; EUT in sweep mode

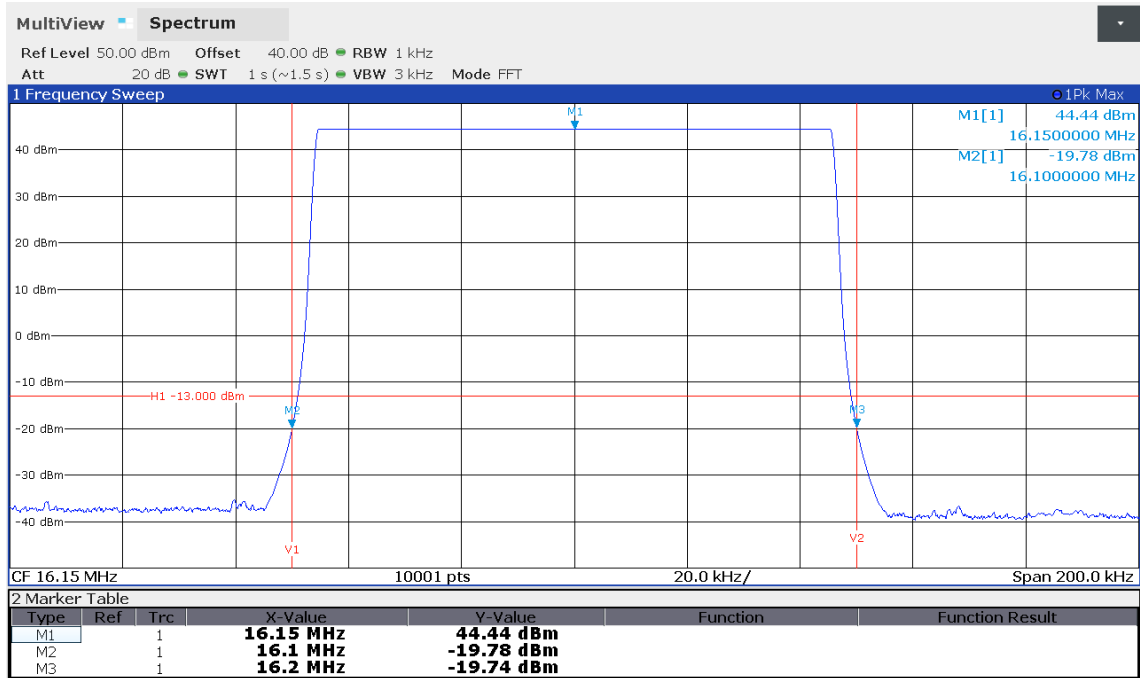

Frequency band: 16.100 MHz to 16.200 MHz; EUT is in ID mode

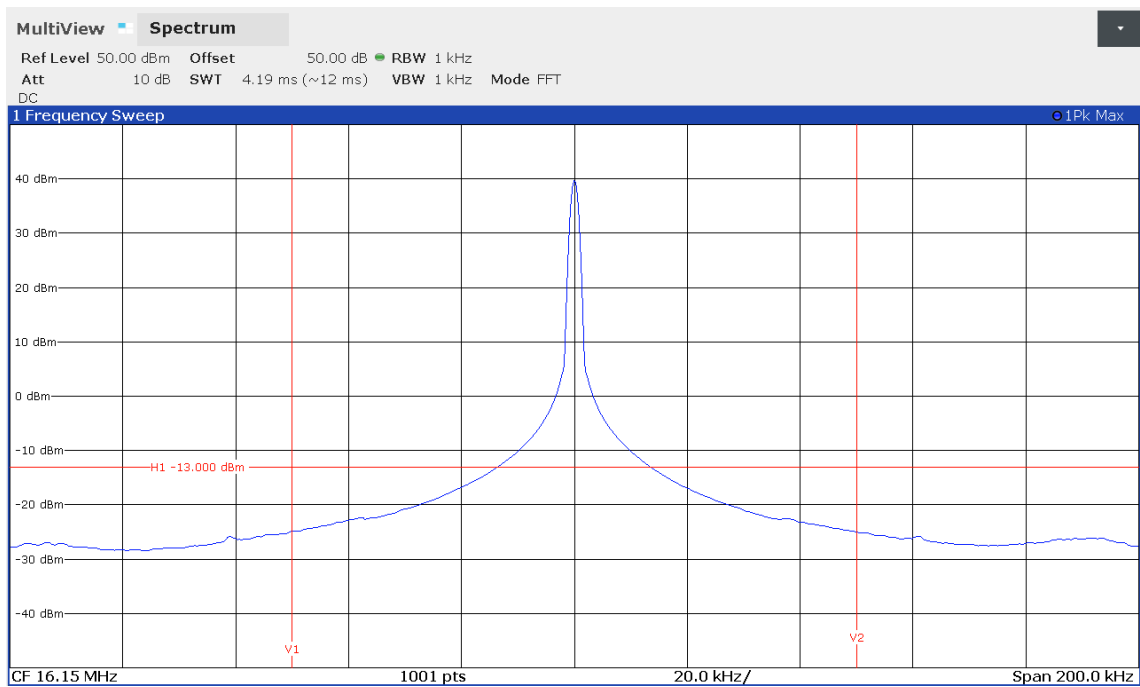

Test: Passed

Limit:

Frequency or band [kHz]	Class of station(s)	Limitation
70 to 90	Radiolocation land or mobile	1
90 to 110	Radiolocation land	2
110 to 130	Radiolocation land or mobile	1
1705 to 1715do	4, 5, 6
1715 to 1750do	5, 6
1750 to 1800	do	5, 6
3230 to 3400do	6, 8
4438 to 4488	Radiolocation land	3
5250 to 5275do	3
[MHz]		
13.45 to 13.55do	3
16.10 to 16.20do	3
24.45 to 24.65do	3
26.20 to 26.42do	3
41.015 to 41.665do	3
43.35 to 44.00do	3
420 to 450	Radiolocation land or mobile	21
2450 to 2500do	9, 22, 23
2900 to 3100do	10, 11
3100 to 3300do	12
3300 to 3500do	12, 13
3500 to 3550do	12
3550 to 3650do	30
5250 to 5350do	12
5350 to 5460do	10, 14
5460 to 5470do	10, 15
5470 to 5600do	10, 11
5600 to 5650do	10, 16
8500 to 9000do	12, 17
9000 to 9200do	10, 14
9200 to 9300do	12
9300 to 9500do	10, 15, 18
9500 to 10,000do	12
10,000 to 10,500do	12, 13, 19
10,500 to 10,550do	20, 22, 24
13,400 to 13,750do	12
13,750 to 14,000do	29
15,700 to 17,300do	
24,050 to 24,250do	12, 22, 24
33,400 to 36,000do	12

(3) Operations in this band are limited to oceanographic radars using transmitters with a peak equivalent isotropically radiated power (EIRP) not to exceed 25 dBW. Oceanographic radars shall not cause harmful interference to, nor claim protection from interference caused by, stations in the fixed or mobile services as specified in §2.106, footnotes 5.132A, 5.145A, and US132A. See Resolution 612 of the ITU Radio Regulations for international coordination requirements and for recommended spectrum sharing techniques.

Test equipment used (refer clause 6):

1 - 5

5.2 Transmitter output power

5.2.1 Method of measurement

Test setup:

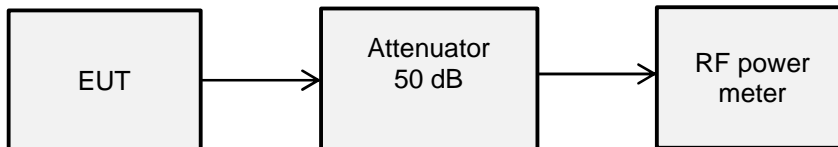

Via the internal user interface the EUT was set to

1. Sweep mode: sweep over the band.
2. ID mode: Transmit its ID in Morse mode.

Supply voltage: 240 V

5.2.2 Test result

Ambient temperature	23 °C	Relative humidity	70 %
---------------------	-------	-------------------	------

Center Frequency [MHz]	Measured output power [dBm]		Antenna gain * [dBi]	EIRP [dBm]		Limit [dBm]
	Sweep mode	ID mode		Sweep mode	ID mode	
5.2625	45.8	40.1	-2.06	43.7	38.0	55
13.5000	44.8	40.0	-2.66	42.1	37.3	
16.1500	44.6	40.0	+5.32	49.9	45.3	
Measurement uncertainty: ±2.5 dB						

*) as declared by the applicant

Limit:

(3) Operations in this band are limited to oceanographic radars using transmitters with a peak equivalent isotropically radiated power (EIRP) not to exceed 25 dBW. Oceanographic radars shall not cause harmful interference to, nor claim protection from interference caused by, stations in the fixed or mobile services as specified in §2.106, footnotes 5.132A, 5.145A, and US132A. See Resolution 612 of the ITU Radio Regulations for international coordination requirements and for recommended spectrum sharing techniques.

Test: Passed

Test equipment used (refer clause 6):

3 – 5, 16, 17

5.3 Type of emission

Mode	Description	Type of emission
Radar	The transmitted signal is a sine wave sweep over the allocated band with a sweep rate of typical 2 to 4 Hz. It is a CW signal, which is not gated or pulsed.	NXN
ID	ASK is used.	A1A

47 CFR 90.207 (n):

Other emissions. Requests for emissions other than those listed in paragraphs (c) through (e) of this section will be considered on a case-by-case basis to ensure that the requested emission will not cause more interference than other currently permitted emissions.

An inquiry to FCC was made on 27.05.2020.

5.4 Band edge compliance

5.4.1 Method of measurement

Test setup:

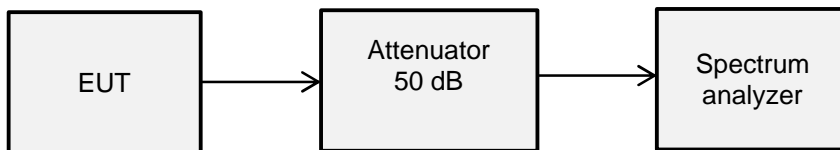

The following spectrum analyser settings for band edge measurements were used:

- Span: 12 kHz / 20 kHz
- Resolution bandwidth: 300 Hz / 1 kHz
- Video bandwidth: 1 kHz
- Mode: FFT
- Sweep time: 21ms / 1s (Sweep mode), auto (ID)
- Detector function: Peak
- Channel power in 10 kHz bandwidth (integration)
- Trace mode: Max hold

Via the internal user interface the EUT was set to

1. Sweep mode: sweep over the band.

Supply Voltage of EUT: 240 V

Remark: The band edge compliance was measured in sweep mode only because this represents the worst case regarding this test case.

5.4.2 Test Results

Ambient temperature	22 °C	Relative humidity	25 %
---------------------	-------	-------------------	------

Frequency band: 5.250 MHz to 5.275 MHz

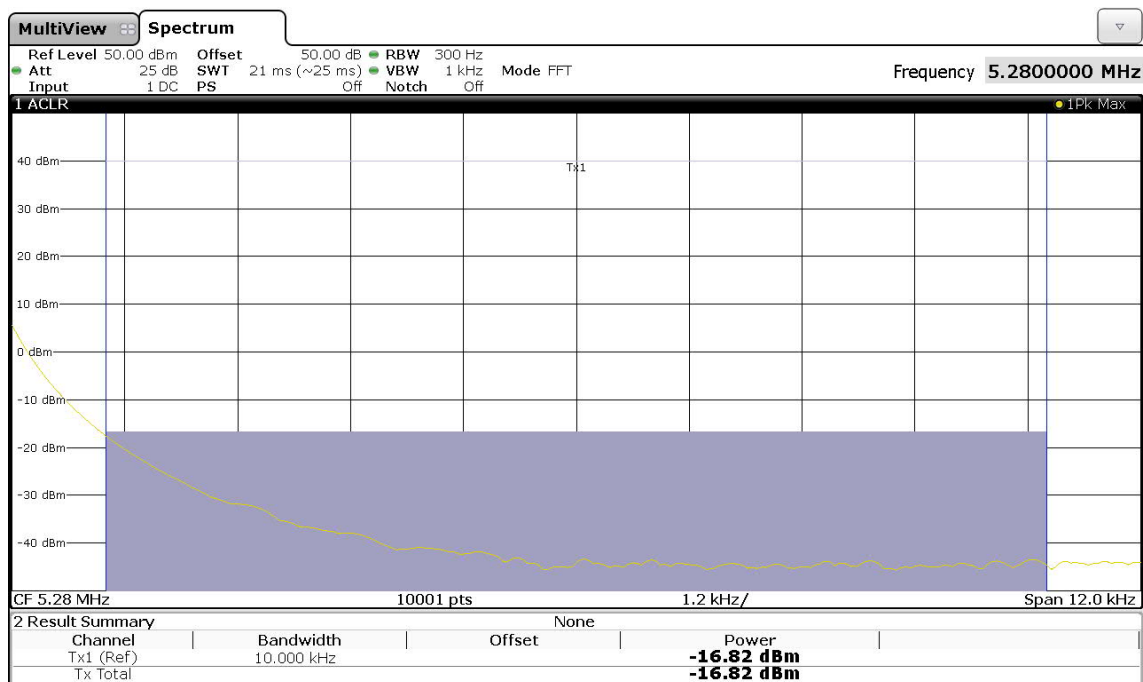
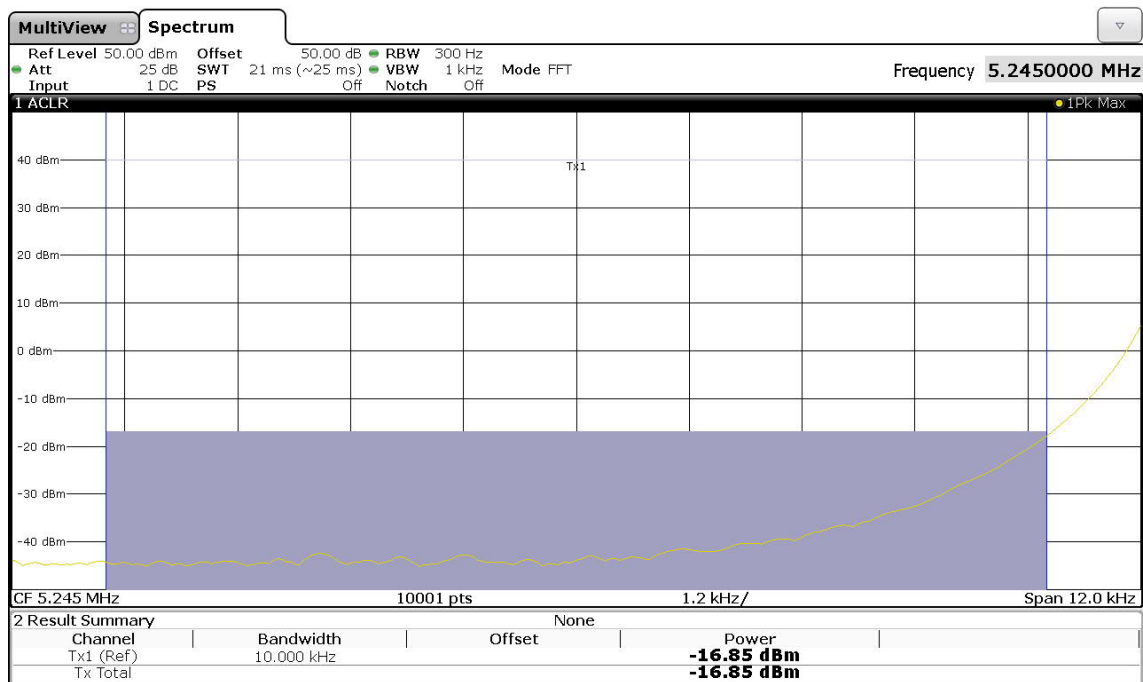

Frequency band: 13.450 MHz to 13.550 MHz

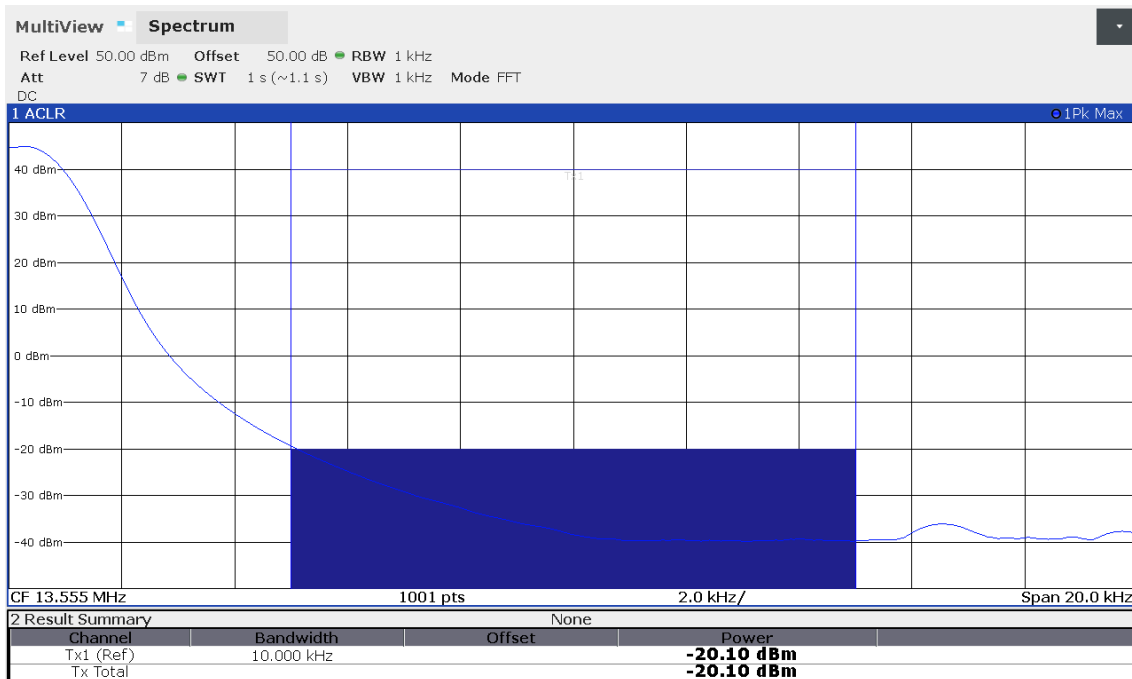

Frequency band: 16.100 MHz to 16.200 MHz

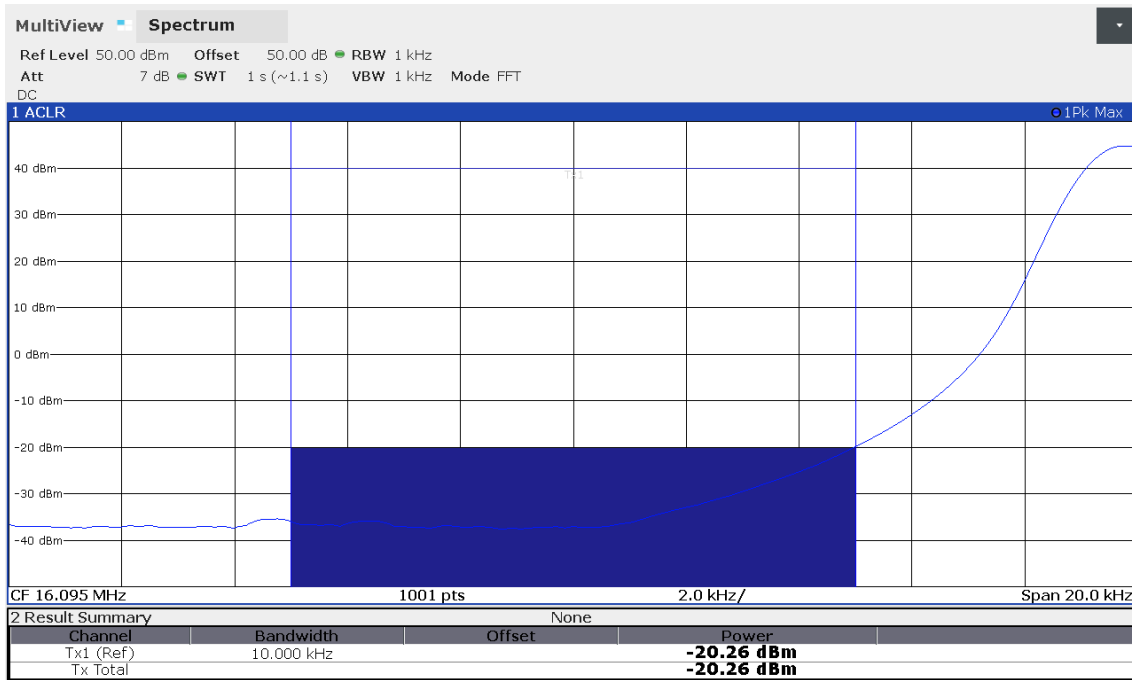

TX center frequency (MHz)	Measurement BW (kHz)	Frequency (MHz)	Level (dBm)	Limit (dBm)
5.2625	10	5.245	-16.8	-13
		5.280	-16.8	
13.500		13.445	-20.2	
		13.555	-20.1	
16.150		16.095	-20.3	
		16.205	-20.4	
Measurement uncertainty: ± 2.5 dB				

Limit:

All unwanted emissions must be attenuated relative to the carrier power by at least $43 + 10\log(P)$

Attenuation for 25 W carrier power: $43 + 10 \log (P) \text{ dB} = 43 + 10 \log (25) \text{ dB} = 57 \text{ dB}$

RF Power limit for any spurious emission: $44 \text{ dBm} - 57 \text{ dB} = -13 \text{ dBm}$

Test: Passed

Test equipment used (refer clause 6):

1 - 5

5.5 Spurious emissions (conducted)

5.5.1 Method of measurement

Test setup:

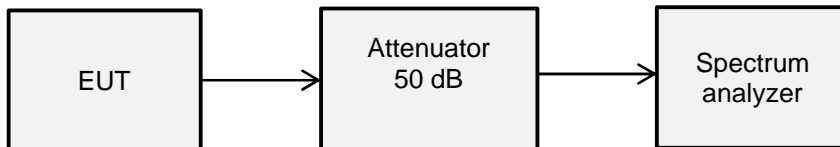

The following spectrum analyser settings for band edge measurements were used:

- Span: 12 kHz / 20 kHz
- Resolution bandwidth: 300 Hz / 10 kHz / 100 kHz
- Video bandwidth: 1 kHz / 30 kHz / 300 kHz
- Mode: sweep
- Sweep time: auto
- Detector function: Peak
- Trace mode: Max hold

Via the internal user interface the EUT was set to sweep mode (sweep over the band).

Supply Voltage of EUT: 240 V

5.5.1.1 Spurious emissions

Frequency band: 5.250 MHz to 5.275 MHz

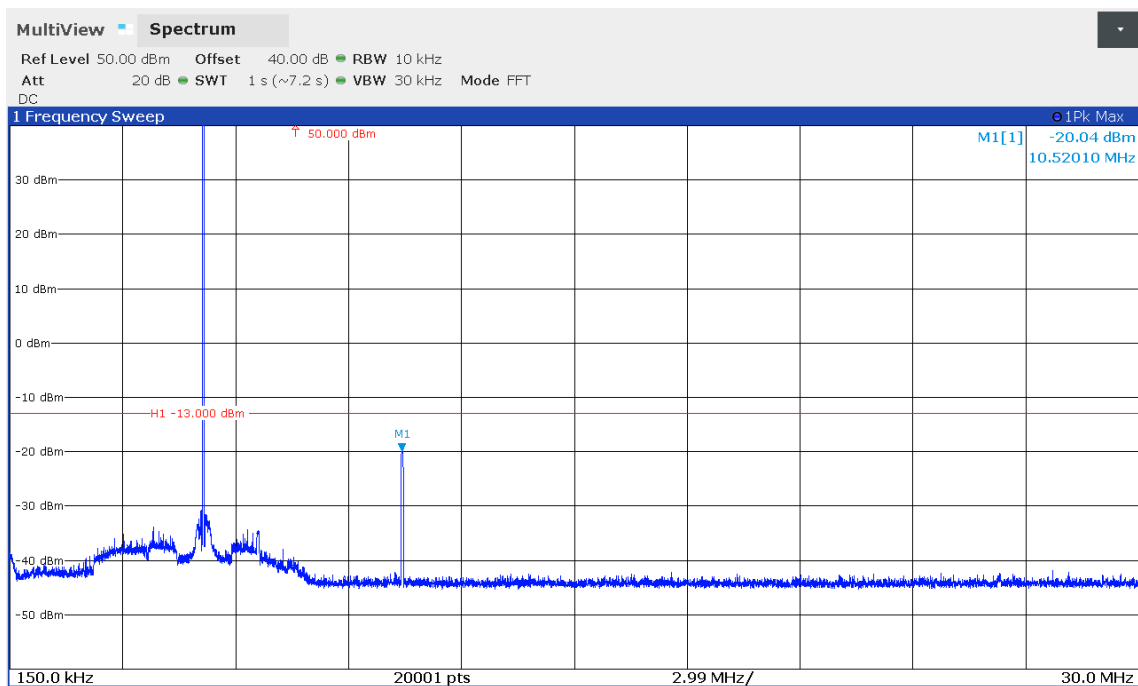
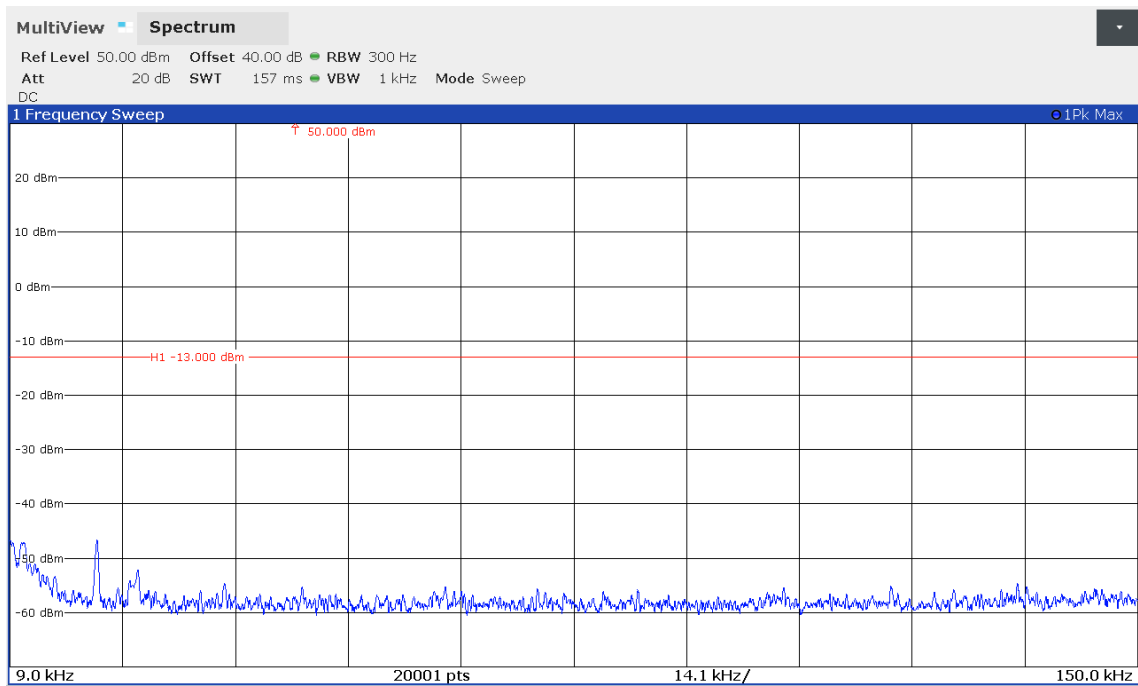

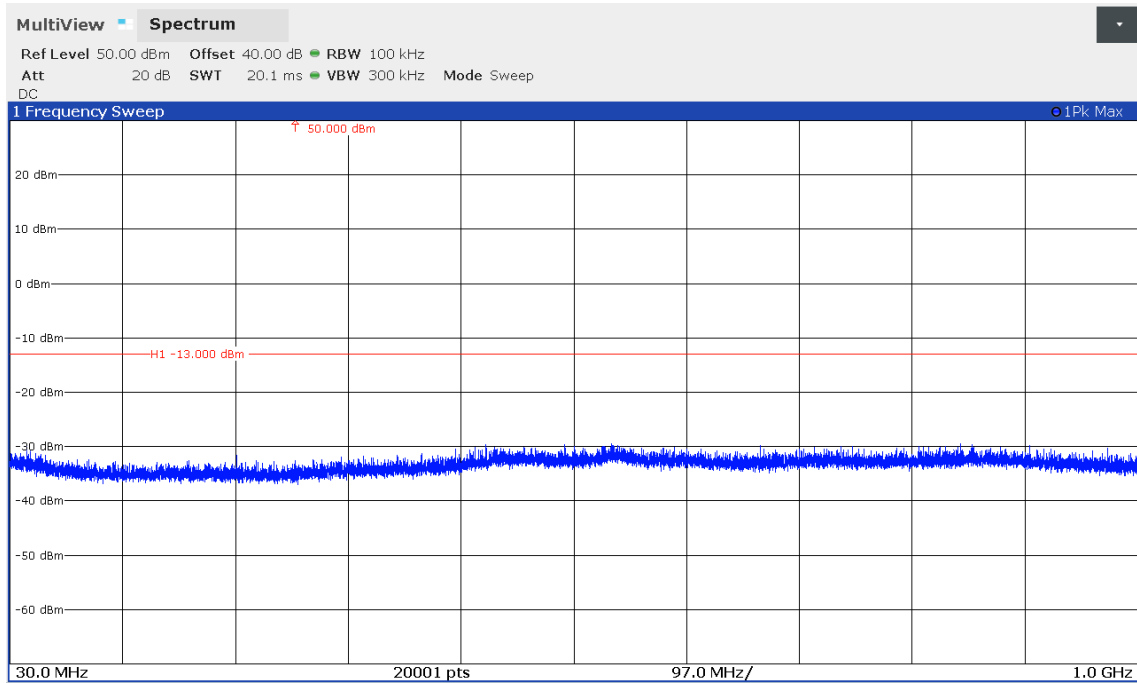

TX center frequency (MHz)	Frequency (MHz)	Measurement BW (kHz)	Level QP (dBm)	Limit (dBm)
5.2625	10.528	10	-23.0	-13
	-	-	-	
	-	-	-	
	-	-	-	
	-	-	-	
	-	-	-	
Measurement uncertainty: ± 2.5 dB				

Frequency band: 13.450 MHz to 13.550 MHz

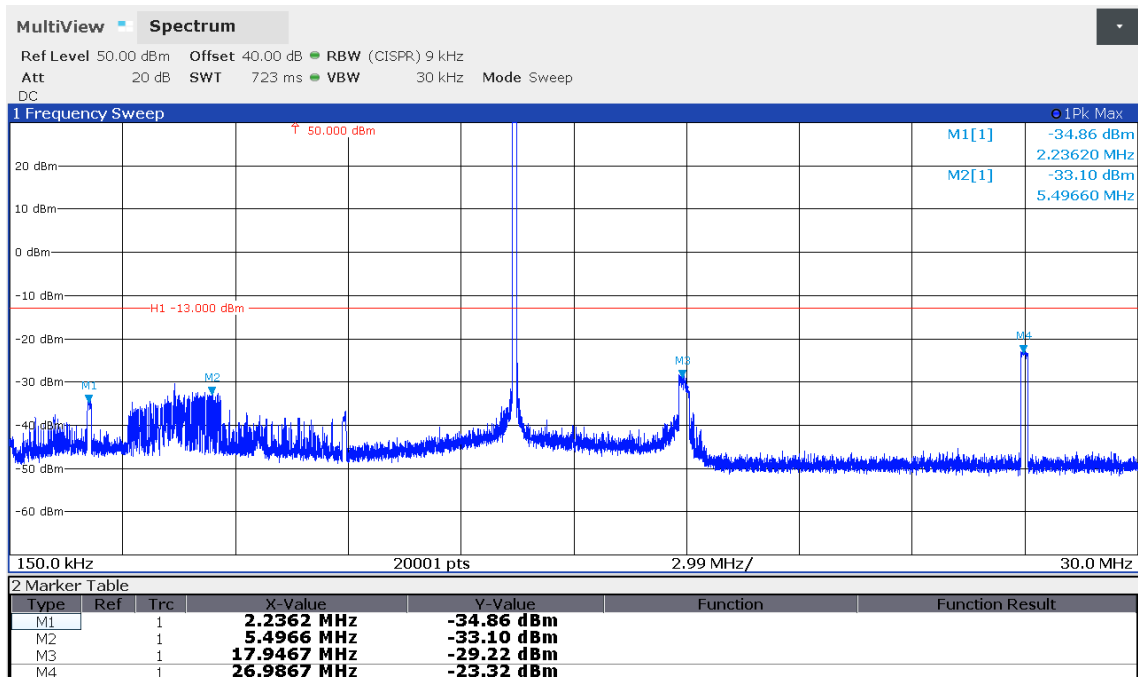
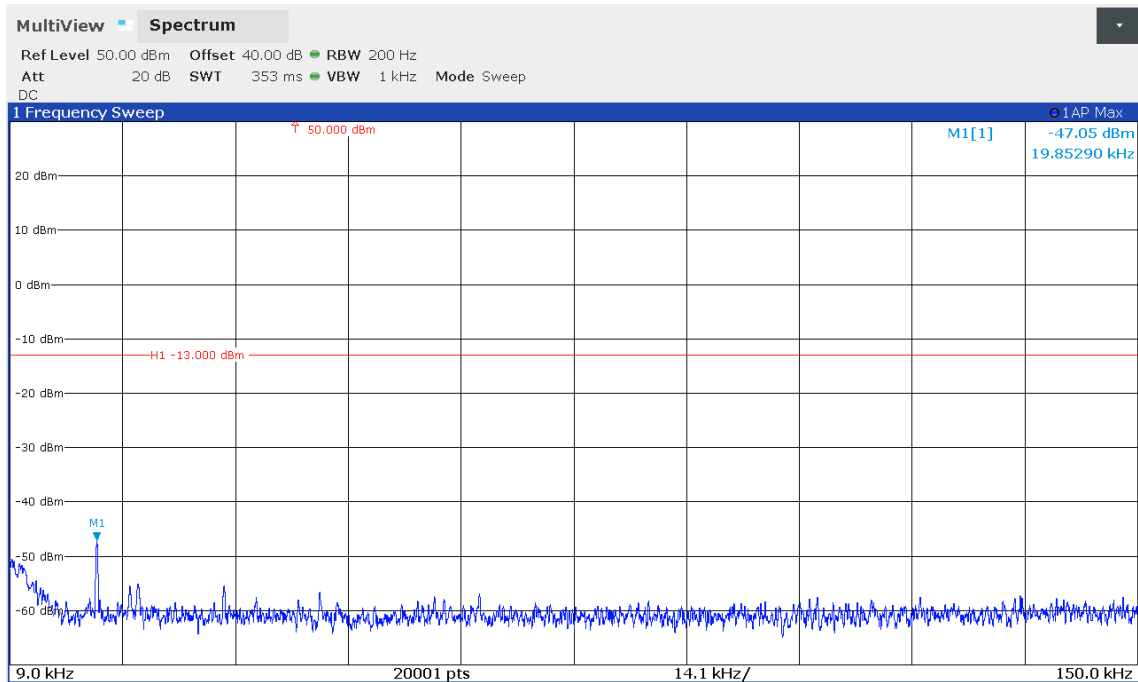

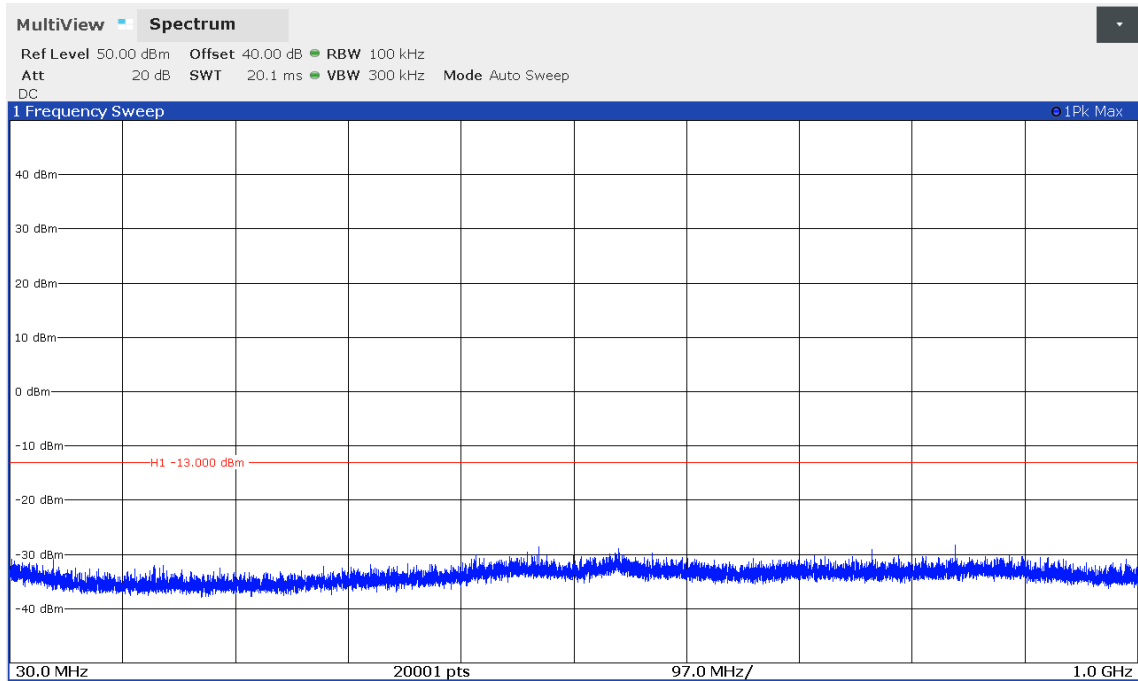

TX center frequency (MHz)	Frequency (MHz)	Measurement BW (kHz)	Level QP (dBm)	Limit 528(dBm)
13.500	2.255	10	-38.5	-13
	4.500	10	-38.7	
	17.956	10	-33.2	
	27.011	10	-26.6	
	-	-	-	
	-	-	-	
Measurement uncertainty: ± 2.5 dB				

Frequency band: 16.100 MHz to 16.200 MHz

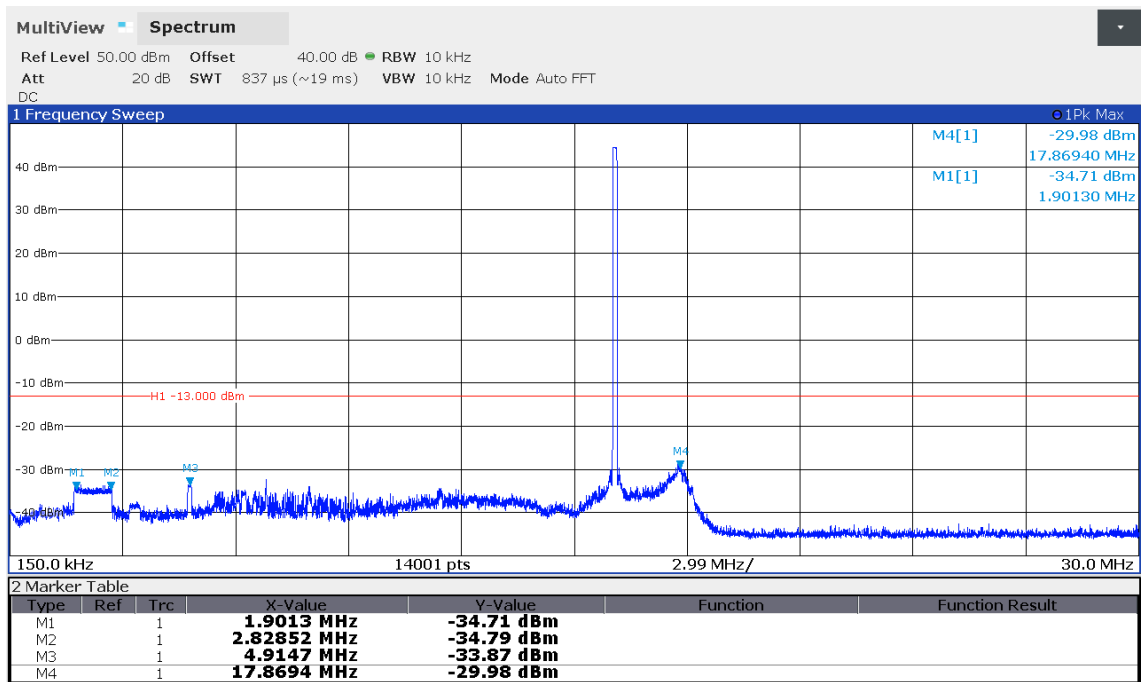
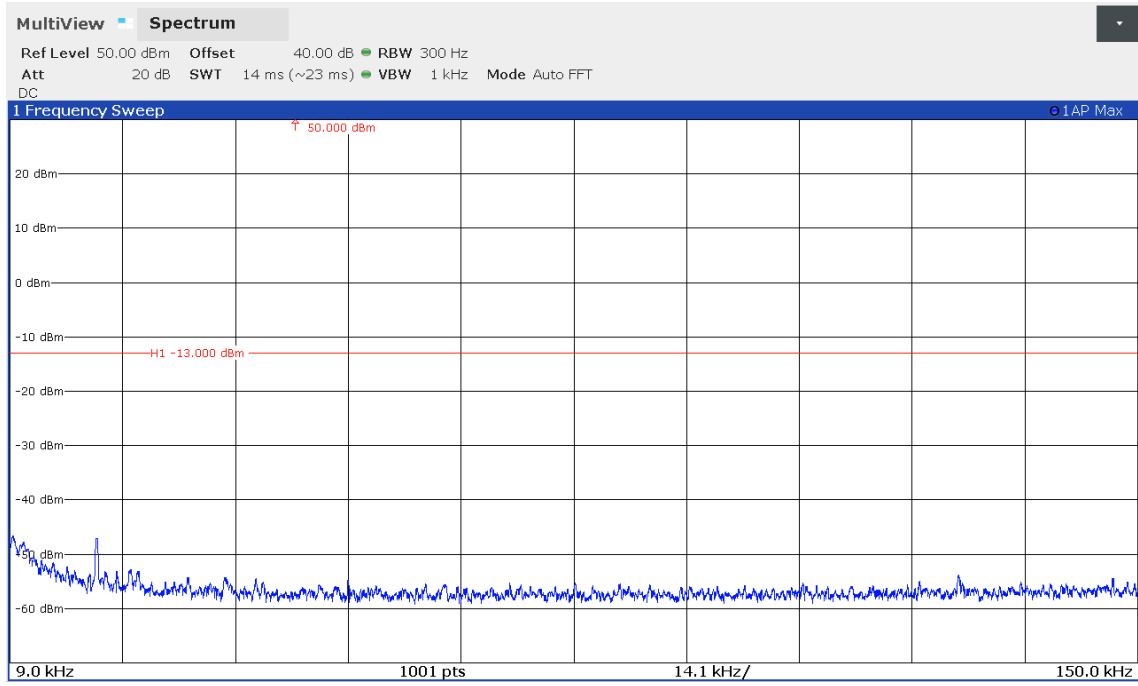

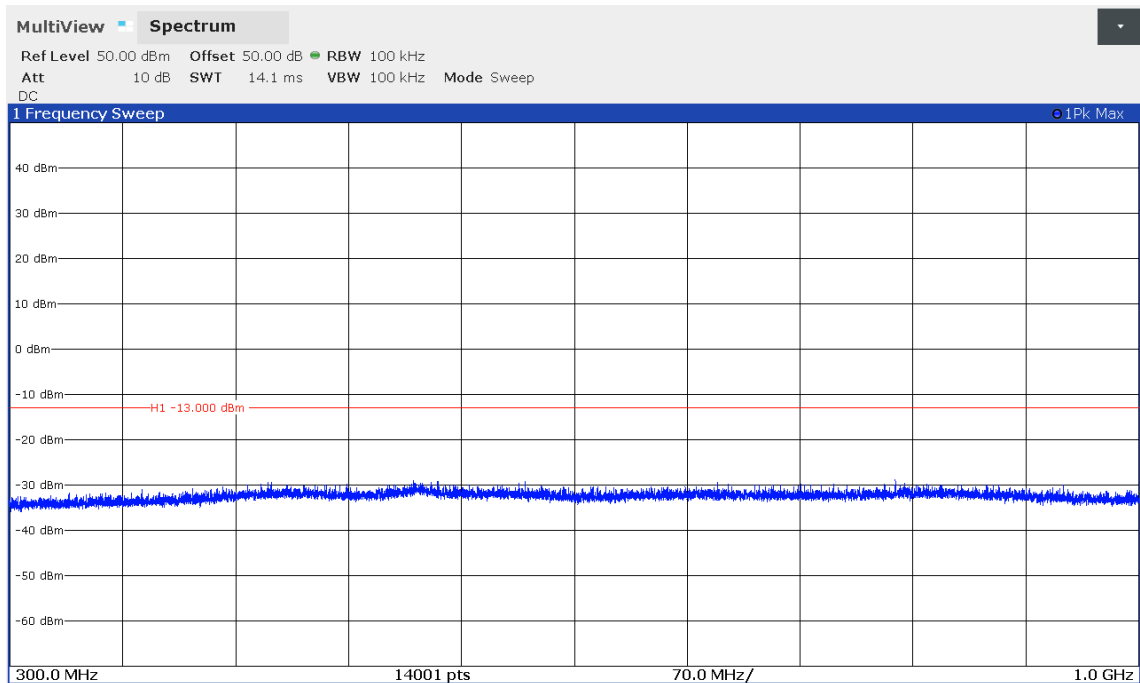
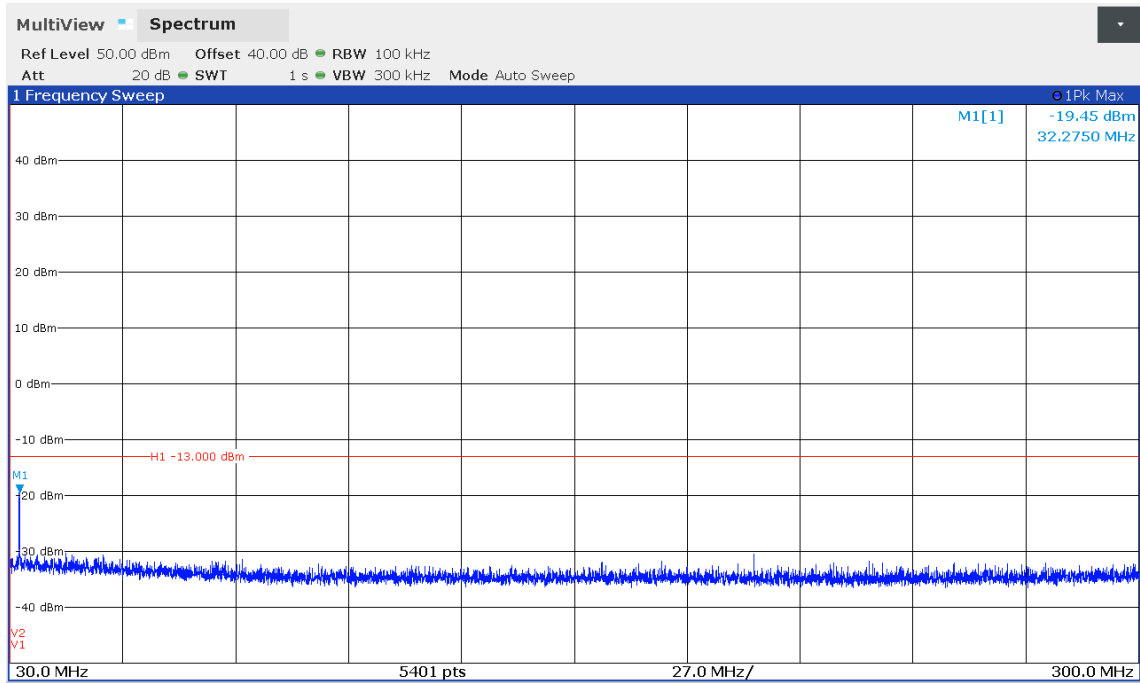

TX center frequency (MHz)	Frequency (MHz)	Measurement BW (kHz)	Level QP (dBm)	Limit 528(dBm)
16.150	2.200	9	-39.5	-13
	4.913	9	-37.8	
	17.880	9	-38.4	
	32.322	120	-21.1	
	-	-	-	
	-	-	-	
Measurement uncertainty: ± 2.5 dB				

Limit:

All unwanted emissions must be attenuated relative to the carrier power by at least $43 + 10\log(P)$.

Attenuation for 25 W carrier power: $43 + 10 \log (P)$ dB = $43 + 10 \log (25)$ dB = 57 dB

RF Power limit for any spurious emission: 44 dBm - 57 dB = -13 dBm

Test: Passed

Test equipment used (refer clause 6):

1, 3 - 5

5.6 Spurious emissions (radiated)

5.6.1 Method of measurement

The radiated emission measurement is subdivided into three stages.

- A preliminary measurement carried out in a semi anechoic chamber with a fixed antenna height in the frequency range 9 kHz to 30 GHz.
- A final measurement carried out on an outdoor test site without reflecting ground plane and a fixed antenna height in the frequency range 9 kHz to 30 MHz.
- A preliminary and final measurement carried out in a semi anechoic chamber with reflecting ground plane and various antenna heights in the frequency range 30 MHz to 200 MHz.

Preliminary measurement (9 kHz to 30 MHz):

In the first stage a preliminary measurement will be performed in a shielded room with a measuring distance of 3 meters. Table-top devices will be set up on a non-conducting support with a size of 1 m by 1.5 m and a height of 80 cm. Floor-standing devices will be placed directly on the turntable/ground plane. The setup of the Equipment under test will be in accordance to [3].

The frequency range 9 kHz to 30 MHz will be monitored with a spectrum analyser while the system and its cables will be manipulated to find out the configuration with the maximum emission levels if applicable. The EMI Receiver will be set to MAX Hold mode. The EUT and the measuring antenna will be rotated around their vertical axis to find the maximum emissions.

The resolution bandwidth of the spectrum analyser will be set to the following values:

Frequency range	Resolution bandwidth
9 kHz to 150 kHz	200 Hz
150 kHz to 30 MHz	10 kHz

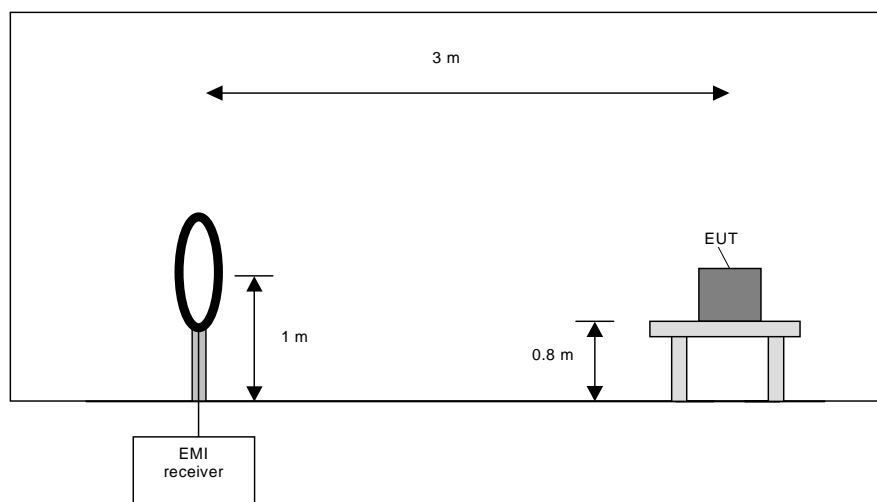

Preliminary measurement procedure:

Prescans were performed in the frequency range 9 kHz to 150 kHz and 150 kHz to 30 MHz.

The following procedure will be used:

- 1) Monitor the frequency range at horizontal polarisation and a EUT azimuth of 0 °.
- 2) Manipulate the system cables within the range to produce the maximum level of emission.
- 3) Rotate the EUT by 360 ° to maximize the detected signals.
- 4) Make a hardcopy of the spectrum.
- 5) Measure the frequencies of highest detected emission with a lower span and resolution bandwidth to increase the accuracy and note the frequency value.
- 6) Repeat steps 1) to 5) with the other orthogonal axes of the EUT (because of EUT is a module and might be used in a handheld equipment application).
- 7) Rotate the measuring antenna and repeat steps 1) to 5).

Final measurement (9 kHz to 30 MHz):

In the second stage a final measurement will be performed on an open area test site with no conducting ground plane in a measuring distances of 3 m, 10 m and 30 m

On the frequencies, which were detected during the preliminary measurements, the final measurement will be performed while rotating the EUT and the measuring antenna in the range of 0 ° to 360 ° around their vertical axis until the maximum value is found.

The resolution bandwidth of the EMI Receiver will be set to the following values:

Frequency range	Resolution bandwidth
9 kHz to 150 kHz	200 Hz
150 kHz to 30 MHz	9 kHz

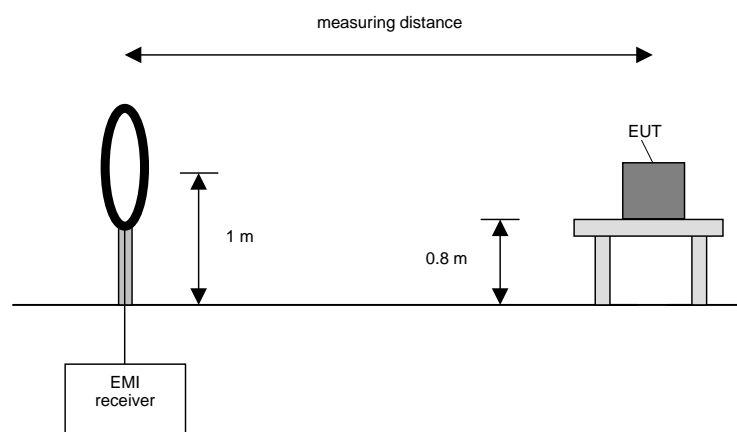

Final measurement procedure:

The following procedure will be used:

- 1) Monitor the frequency range with the measuring antenna at vertical orientation parallel to the EUT at an azimuth of 0 °.
- 2) Rotate the EUT by 360 ° to maximize the detected signals and note the azimuth and orientation.
- 3) Rotate the measuring antenna to find the maximum and note the value.
- 4) Rotate the measuring antenna and repeat steps 1) to 3) until the maximum value is found.
- 5) If the EUT is a module and might be used in a handheld equipment application:
Repeat steps 1) to 4) with the other orthogonal axes of the EUT.

Preliminary measurement (30 MHz to 1 GHz)

In the first stage a preliminary measurement will be performed in a fully anechoic chamber with a measuring distance of 3 meter. Table top devices will set up on a non-conducting table on the height of 0.8 m. Floor-standing devices will be placed directly on the turntable/ground plane.

The frequency range 30 MHz to 1 GHz will be measured with an EMI Receiver set to MAX Hold mode and a resolution bandwidth of 100 kHz. The measurement will be performed in horizontal and vertical polarisation of the measuring antenna and while rotating the EUT in its vertical axis in the range of 0 ° to 360 °. The measurement antenna will be positioned from 1 to 4 m in 0.5 m steps. The position for each antenna position and antenna polarization for each measurement point will be stored in the measurement software.

The resolution bandwidth of the EMI Receiver will be set to the following values:

Frequency range	Resolution bandwidth
30 MHz to 200 MHz	100 kHz
200 MHz to 1 GHz	100 kHz

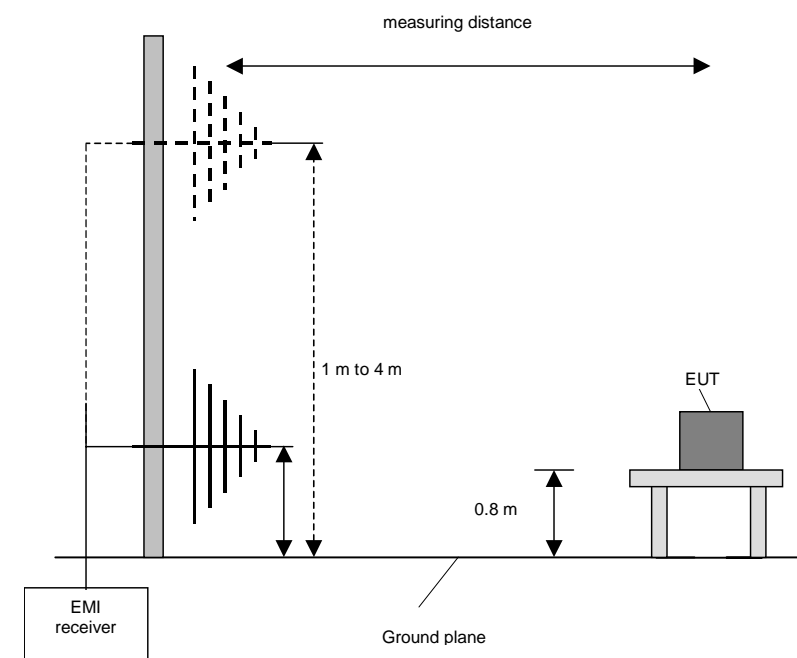

For the final measurement the highest emissions, closest to the limit line will be selected. For each emission a continuous partial scan for 1 m antenna height and 50° azimuth at the turntable will be performed, to determine the worst case.

The final measurement will be performed in the position and the azimuth of the determined position with an quasipeak detector at a bandwidth of 120 kHz CISPR).

The correction factor for the measurement values was determined using the substitution method.cribed in 5.5.3 of [1].

5.6.2 Radiated emission measurement

Ambient temperature	23 °C	Relative humidity	41 %
---------------------	-------	-------------------	------

Position of EUT: The EUT was placed directly on the turntable/ground plane.
The distance between EUT and antenna was 3 m.

Cable guide: For detail information of test set-up and the cable guide refer to the pictures in Annex A.

Test record: All results are shown in the following.

Supply voltage: During all measurements the EUT was powered with 240 V AC / 60 Hz by laboratory power supply.

Remark: The antenna terminal was terminated with 50 ohms.

Via the internal user interface the EUT was set to

1. Sweep mode: sweep over the band.

Supply Voltage of EUT: 240 V

Frequency band: 5.250 MHz to 5.275 MHz

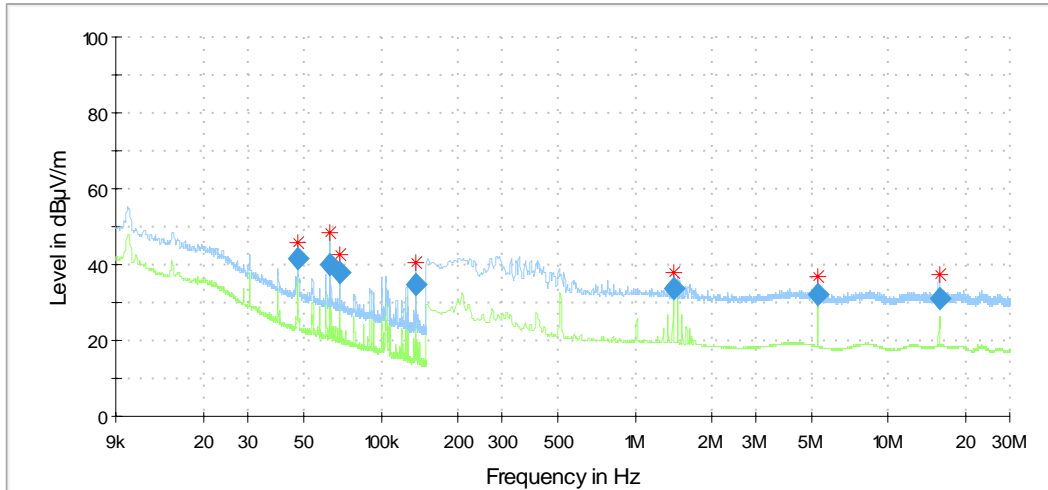

Frequency (MHz)	Reading@3m (dBµV/m)	Result@norm.dist. (dBµV/m)	Limit (dBµV/m)	Margin (dB)	Meas. Time (ms)	Bandwidth (kHz)	Corr. (dB/m)
0.047	41.7	-38.3 @ 300m	34.2	72.5	1000.0	0.200	20.2
0.063	40.1	-39.9 @ 300m	31.6	71.5	1000.0	0.200	20.1
0.068	37.8	-42.2 @ 300m	30.9	73.1	1000.0	0.200	20.1
0.137	34.7	-45.3 @ 300m	24.9	70.2	1000.0	0.200	20.1
1.414	33.6	-6.4 @ 30m	24.6	31.0	1000.0	9.000	20.1
5.262	32.3	-7.7 @ 30m	29.5	37.2	1000.0	9.000	20.2
15.783	31.3	-8.7 @ 30m	29.5	38.2	1000.0	9.000	20.3

Measurement uncertainty: ±4.4 dB

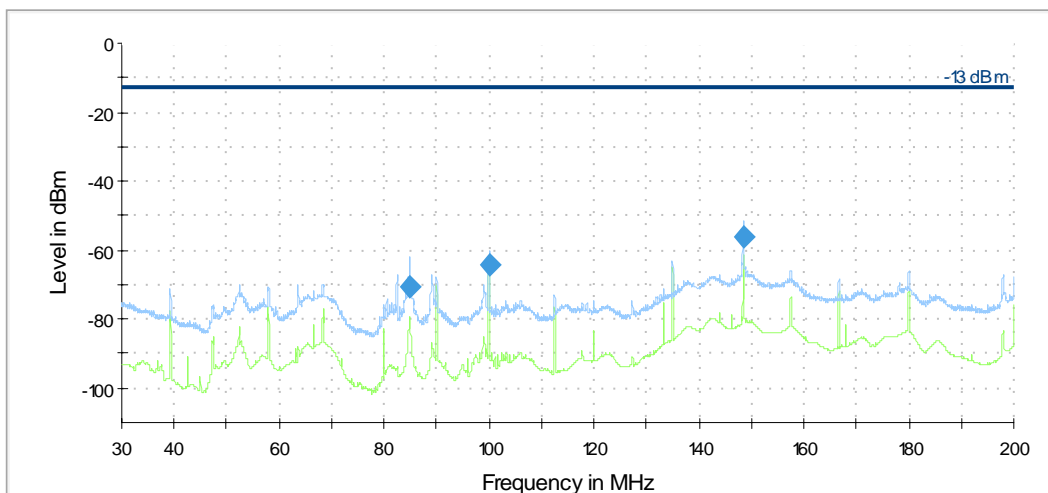

Frequency (MHz)	QuasiPeak (dBm)	Limit (dBm)	Margin (dB)	Meas. Time (ms)	Bandwidth (kHz)	Height (cm)	Pol	Azimuth (deg)	Corr. (dB)
84.860	-70.7	-13.00	57.7	1000.0	120.000	103.0	V	178.0	-87.1
100.000	-64.3	-13.00	51.3	1000.0	120.000	103.0	V	185.0	-85.1
148.480	-56.3	-13.00	43.3	1000.0	120.000	150.0	V	179.0	-82.9

Measurement uncertainty: ±5.1 dB

Frequency band: 13.450 MHz to 13.550 MHz

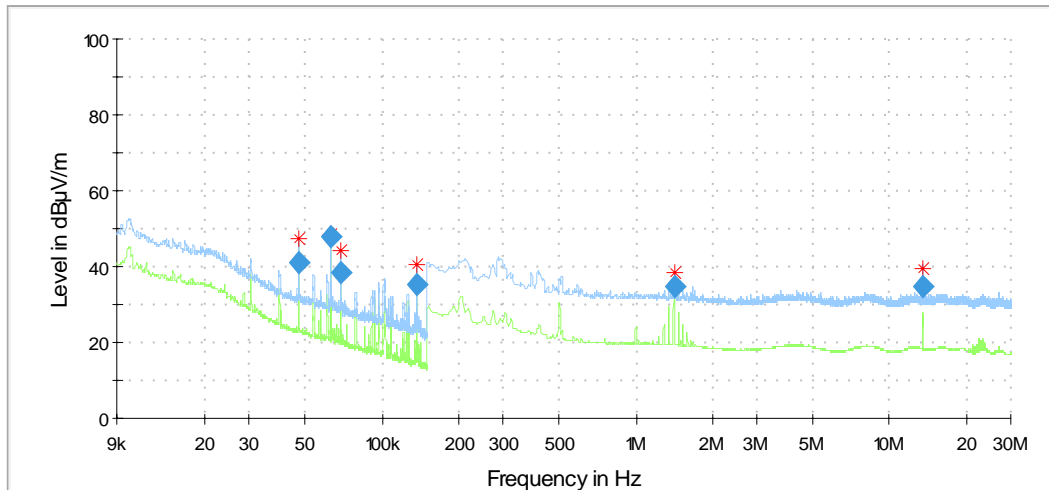

Frequency (MHz)	Reading@3m (dBµV/m)	Result@norm.dist. (dBµV/m)	Limit (dBµV/m)	Margin (dB)	Meas. Time (ms)	Bandwidth (kHz)	Corr. (dB/m)
0.047	40.9	-39.1 @ 300m	34.2	73.3	1000.0	0.200	20.2
0.063	48.0	-32.0 @ 300m	31.6	63.6	1000.0	0.200	20.1
0.068	38.6	-41.4 @ 300m	30.9	72.3	1000.0	0.200	20.1
0.137	35.0	-45.0 @ 300m	24.9	69.9	1000.0	0.200	20.1
1.414	34.7	-5.3 @ 30m	24.6	29.9	1000.0	9.000	20.1
15.783	34.5	-5.5 @ 30m	29.5	35.0	1000.0	9.000	20.3

Measurement uncertainty: ±4.4 dB

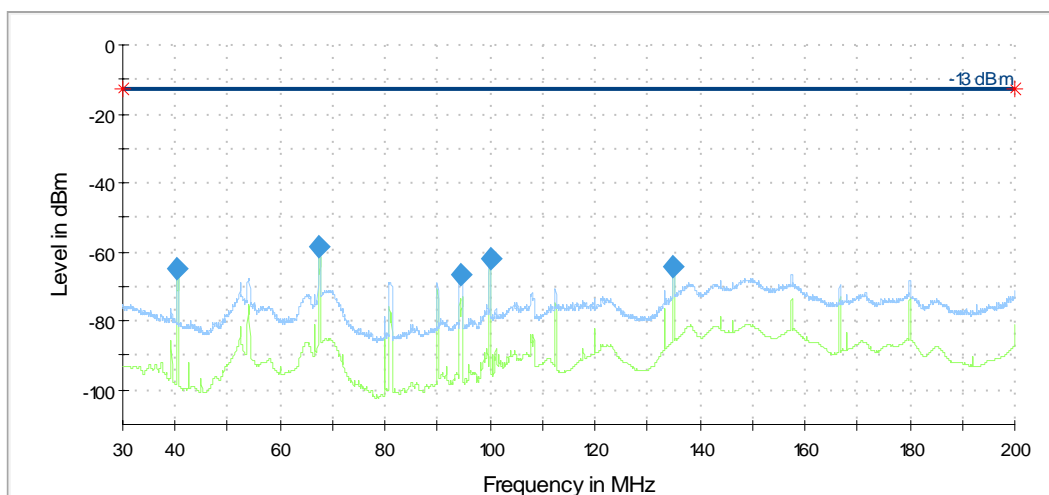

Frequency (MHz)	QuasiPeak (dBm)	Limit (dBm)	Margin (dB)	Meas. Time (ms)	Bandwidth (kHz)	Height (cm)	Pol	Azimuth (deg)	Corr. (dB)
40.480000	-64.58	-13.00	51.58	1000.0	120.000	115.0	V	5.0	-88.4
67.390000	-58.19	-13.00	45.19	1000.0	120.000	136.0	V	-14.0	-87.3
94.590000	-66.42	-13.00	53.42	1000.0	120.000	100.0	V	-7.0	-85.7
100.000000	-61.90	-13.00	48.90	1000.0	120.000	100.0	V	179.0	-85.1
135.000000	-64.25	-13.00	51.25	1000.0	120.000	100.0	V	89.0	-84.1

Measurement uncertainty: ±5.1 dB

Frequency band: 16.100 MHz to 16.200 MHz

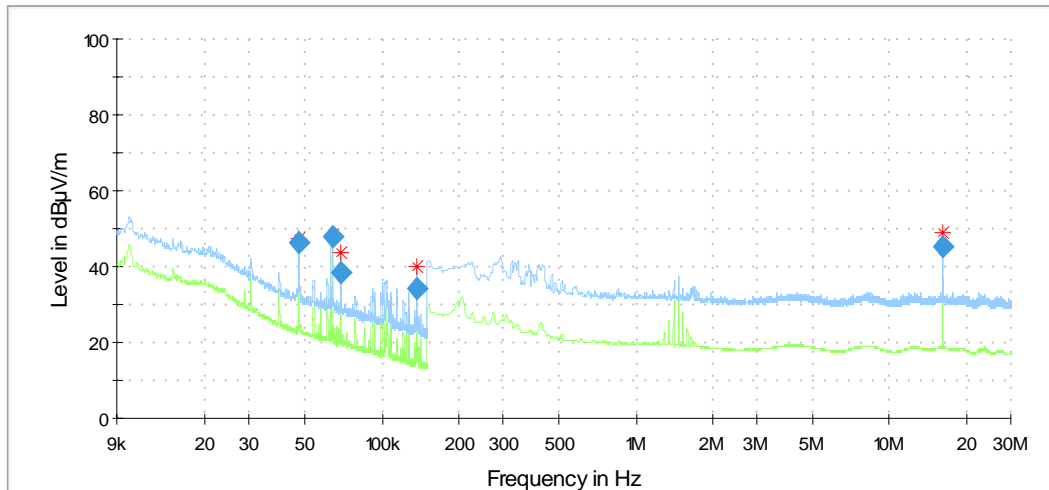

Frequency (MHz)	Reading@3m (dBµV/m)	Result@norm.dist. (dBµV/m)	Limit (dBµV/m)	Margin (dB)	Meas. Time (ms)	Bandwidth (kHz)	Corr. (dB/m)
0.047	46.5	-33.5 @ 300m	34.2	67.7	1000.0	0.200	20.2
0.063	48.0	-32.0 @ 300m	31.6	63.6	1000.0	0.200	20.1
0.068	38.6	-41.4 @ 300m	30.9	72.9	1000.0	0.200	20.1
0.137	34.0	-46.0 @ 300m	24.9	70.9	1000.0	0.200	20.1
16.150	45.0	5.0 @ 30m	29.5	24.5	1000.0	9.000	20.3

Measurement uncertainty: ±4.4 dB

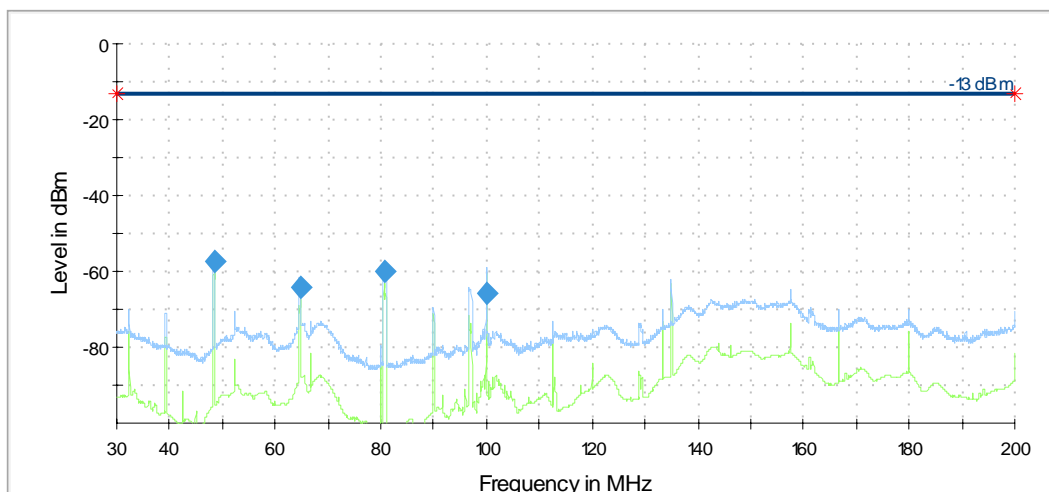

Frequency (MHz)	QuasiPeak (dBm)	Limit (dBm)	Margin (dB)	Meas. Time (ms)	Bandwidth (kHz)	Height (cm)	Pol	Azimuth (deg)	Corr. (dB)
48.430000	-57.40	-13.00	44.40	1000.0	120.000	126.0	V	-1.0	-87.2
64.660000	-64.00	-13.00	51.00	1000.0	120.000	137.0	V	340.0	-87.3
80.680000	-60.07	-13.00	47.07	1000.0	120.000	150.0	V	320.0	-87.8
100.000000	-65.69	-13.00	52.69	1000.0	120.000	100.0	V	185.0	-85.1

Measurement uncertainty: ±5.1 dB

Limit:

All unwanted emissions must be attenuated relative to the carrier power by at least $43 + 10\log(P)$

Attenuation for 25 W carrier power: $43 + 10 \log (P) \text{ dB} = 43 + 10 \log (25) \text{ dB} = 57 \text{ dB}$

RF Power limit for any spurious emission: $44 \text{ dBm} - 57 \text{ dB} = -13 \text{ dBm}$

Test: Passed

Test equipment used (refer clause 6):

7 - 15

5.7 Frequency Stability

5.7.1 Method of measurement

Test setup:

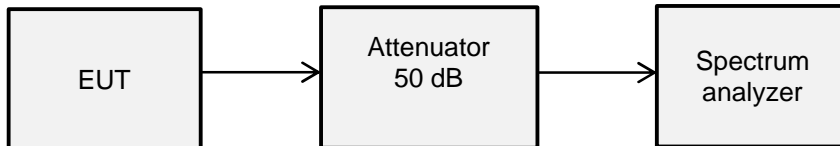

Test was performed at 5.2625 MHz, 13.500 MHz and 16.150 MHz.

Via the internal user interface the EUT was set to
1. CW mode: CW signal in the middle of the band.

Supply Voltage of EUT: see results below

5.7.1.1 Test results

Ambient temperature	28 °C	Relative humidity	54 %
---------------------	-------	-------------------	------

Frequency stability versus voltage variations

Voltage	Frequency (MHz)		Frequency error		
	measured	nominal	(Hz)	(ppm)	Limit (ppm)
Nominal voltage (120 V/60 Hz)	5.262504	5.262500	+4	+0.76	100
85% of nominal voltage (102 V/60 Hz)	5.262504	5.262500	+4	+0.76	100
115% of nominal voltage (138 V/60 Hz)	5.262504	5.262500	+4	+0.76	100
Measurement uncertainty: $4.54 \cdot 10^{-8}$					

Voltage	Frequency (MHz)		Frequency error		
	measured	nominal	(Hz)	(ppm)	Limit (ppm)
Nominal voltage (240 V/60 Hz)	5.262504	5.262500	+4	+0.76	100
85% of nominal voltage (204 V/60 Hz)	5.262504	5.262500	+4	+0.76	100
115% of nominal voltage (276 V/60 Hz)	5.262504	5.262500	+4	+0.76	100
Measurement uncertainty: $4.54 \cdot 10^{-8}$					

Voltage	Frequency (MHz)		Frequency error		
	measured	nominal	(Hz)	(ppm)	Limit (ppm)
Nominal voltage (120 V/60 Hz)	13.500011	13.500000	+11	+0.81	100
85% of nominal voltage (102 V/60 Hz)	13.500011	13.500000	+11	+0.81	100
115% of nominal voltage (138 V/60 Hz)	13.500011	13.500000	+11	+0.81	100
Measurement uncertainty: $<10^{-7}$ (frequency)					

Voltage	Frequency (MHz)		Frequency error		
	measured	nominal	(Hz)	(ppm)	Limit (ppm)
Nominal voltage (240 V/60 Hz)	13.500011	13.500000	+11	+0.81	100
85% of nominal voltage (204 V/60 Hz)	13.500011	13.500000	+11	+0.81	100
115% of nominal voltage (276 V/60 Hz)	13.500011	13.500000	+11	+0.81	100
Measurement uncertainty: $4.54 \cdot 10^{-8}$					

Voltage	Frequency (MHz)		Frequency error		
	measured	nominal	(Hz)	(ppm)	Limit (ppm)
Nominal voltage (120 V/60 Hz)	16.150013	16.150000	+13	+0.80	100
85% of nominal voltage (102 V/60 Hz)	16.150013	16.150000	+13	+0.80	100
115% of nominal voltage (138 V/60 Hz)	16.150013	16.150000	+13	+0.80	100
Measurement uncertainty: $4.54 \cdot 10^{-8}$					

Voltage	Frequency (MHz)		Frequency error		
	measured	nominal	(Hz)	(ppm)	Limit (ppm)
Nominal voltage (240 V/60 Hz)	16.150013	16.150000	+13	+0.80	100
85% of nominal voltage (204 V/60 Hz)	16.150013	16.150000	+13	+0.80	100
115% of nominal voltage (276 V/60 Hz)	16.150013	16.150000	+13	+0.80	100
Measurement uncertainty: $4.54 \cdot 10^{-8}$					

Frequency stability versus temperature variations, Operating voltage 120V / 60 Hz

Temperature (°C)	Frequency (MHz)		Frequency error		
	measured	nominal	(Hz)	(ppm)	Limit (ppm)
10	5.262504	5.262500	+4	+0.76	100
20	5.262504	5.262500	+4	+0.76	100
30	5.262504	5.262500	+4	+0.76	100
Measurement uncertainty: $4.54 \cdot 10^{-8}$					

Temperature (°C)	Frequency (MHz)		Frequency error		
	measured	nominal	(Hz)	(ppm)	Limit (ppm)
10	13.500011	13.500000	+11	+0.81	100
20	13.500011	13.500000	+11	+0.81	100
30	13.500011	13.500000	+11	+0.81	100
Measurement uncertainty: $4.54 \cdot 10^{-8}$					

Temperature (°C)	Frequency (MHz)		Frequency error		
	measured	nominal	(Hz)	(ppm)	Limit (ppm)
10	16.150013	16.150000	+13	+0.80	100
20	16.150013	16.150000	+13	+0.80	100
30	16.150013	16.150000	+13	+0.80	100
Measurement uncertainty: $4.54 \cdot 10^{-8}$					

Frequency stability versus temperature variations, Operating voltage 240V / 60 Hz

Temperature (°C)	Frequency (MHz)		Frequency error		
	measured	nominal	(Hz)	(ppm)	Limit (ppm)
10	5.262504	5.262500	+4	+0.76	100
20	5.262504	5.262500	+4	+0.76	100
30	5.262504	5.262500	+4	+0.76	100
Measurement uncertainty: $4.54 \cdot 10^{-8}$					

Temperature (°C)	Frequency (MHz)		Frequency error		
	measured	nominal	(Hz)	(ppm)	Limit (ppm)
10	13.500011	13.500000	+11	+0.81	100
20	13.500011	13.500000	+11	+0.81	100
30	13.500011	13.500000	+11	+0.81	100
Measurement uncertainty: $4.54 \cdot 10^{-8}$					

Temperature (°C)	Frequency (MHz)		Frequency error		
	measured	nominal	(Hz)	(ppm)	Limit (ppm)
10	16.150013	16.150000	+13	+0.80	100
20	16.150013	16.150000	+13	+0.80	100
30	16.150013	16.150000	+13	+0.80	100
Measurement uncertainty: $4.54 \cdot 10^{-8}$					

Limit:

The equipment tested shall not deviate more than 100 ppm from the nominal frequency for fixed and base stations.

Test: Passed

Test equipment used (refer clause 6):

1, 3 - 6

6 Test equipment used for tests

No.	Test equipment	Type	Manufacturer	Serial No.	PM. No.	Cal. Date	Cal Due
1	Signal & Spectrum Analyzer	FSW43	Rohde & Schwarz	100586 & 100926	481720	04.03.2020	03.2022
2	EMI Receiver / Spectrum Analyser	ESW44	Rohde & Schwarz	101635	482467	18.02.2020	02.2022
3	AC power supply	AC6803A AC Quelle 2000VA	Keysight	JPVJ002509	482350	Calibration not necessary	
4	Attenuator 30 dB	6818-30-13	Weinschel	PB652	480663	Calibration not necessary	
5	Attenuator 20 dB	WA8 / 18-20-34	Weinschel	-	481451	Calibration not necessary	
6	Climatic chamber	KK15/50 (WK)	RS-Simulatoren	37001701	482703	06.02.2020	02.2021
7	Loop antenna	HFH2-Z2	Rohde & Schwarz	832609/014	480059	14.02.2020	02.2022
8	Systemsoftware M276	EMC32	Rohde & Schwarz	100970	482972	Calibration not necessary	
9	RF Switch Matrix	OSP220	Rohde & Schwarz		482976	Calibration not necessary	
10	Turntable	TT3.0-3t	Maturo	825/2612/.01	483224	Calibration not necessary	
11	Antennasupport	BAM 4.5-P-10kg	Maturo	222/2612.01	483225	Calibration not necessary	
12	Controller	NCD	Maturo	474/2612.01	483226	Calibration not necessary	
13	Semi Anechoic Chamber M276	SAC5-2	Albatross Projects	C62128-A540-A138-10-0006	483227	Calibration not necessary	
14	EMI Testreceiver	ESW44	Rohde & Schwarz	101828	482979	14.11.2019	11.2021
15	Bikon Antenna	VHA 9103B + VHBB 9124	Schwarzbeck Mess-Elektronik	768	483278	Calibration not necessary	
16	Power Meter	NRVD	Rohde & Schwarz	833697/030	480589	11.02.2020	02.2021
17	Thermal power sensor	NRV-Z51	Rohde & Schwarz	825948/004	480247	12.02.2020	02.2021

7 Test site validation

Test equipment	PM. No.	Frequency range	Type of validation	According to	Val. Date	Val Due
Semi anechoic chamber M276	483227	30 – 1000 MHz	NSA	ANSI C63.4a-2017	19.09.2019	18.09.2021

8 Report history

Report Number	Date	Comment
F200562E1	07.09.2020	Initial report
F200562E1 2 nd version	05.10.2020	Typing error in chapter 1.5
-	-	-

9 List of annexes

Annex A Test Setup Photos

5 Pages