

## FCC PART 22/24/27/90 TEST REPORT

FCC Part 22H/Part 24E/Part 27/ Part 90

<b>Report Reference No.</b> .....	<b>LCS211115092AEB</b>
<b>FCC ID</b> .....	<b>2AUZZ-UML3</b>
<b>Date of Issue</b> .....	<b>December 02, 2021</b>
<b>Testing Laboratory Name</b> .....	<b>Shenzhen LCS Compliance Testing Laboratory Ltd.</b>
Address.....	101, 201 Bldg A & 301 Bldg C, Juji Industrial Park Yabianxueziwei, Shajing Street, Baoan District, Shenzhen, 518000, China
<b>Applicant's name</b> .....	<b>Covert Scouting Cameras, LLC</b>
Address.....	4338 Greenridge Spa Road, Lewisburg, KY 42256, US
<b>Test specification</b> .....	
Standard.....	<b>FCC CFR Title 47 Part 2, Part 22H, Part 24E, Part 27, Part 90 TIA-603-E: 2016 KDB971168 D01 Power Meas License Digital Systems v03r01</b>
Test Report Form No.....	LCSEMC-1.0
TRF Originator.....	Shenzhen LCS Compliance Testing Laboratory Ltd.
Master TRF.....	Dated 2011-03
<b>Shenzhen LCS Compliance Testing Laboratory Ltd. All rights reserved.</b>	
This publication may be reproduced in whole or in part for non-commercial purposes as long as the Shenzhen LCS Compliance Testing Laboratory Ltd. is acknowledged as copyright owner and source of the material. Shenzhen LCS Compliance Testing Laboratory Ltd. takes no responsibility for and will not assume liability for damages resulting from the reader's interpretation of the reproduced material due to its placement and context.	
<b>Test item description</b> .....	<b>Wireless Infrared Scouting Camera</b>
Trade Mark.....	COVERT
Test Model.....	UML3
Modulation Type.....	QPSK, 16QAM
Rating.....	Input: DC 6V Battery: 12*AA Batteries
Hardware version.....	L3V50M
Software version.....	DSP: JL3375; MCU: 18056.128.H
Result.....	<b>PASS</b>

**Compiled by:**



Diamond Lu/ Administrator

**Supervised by:**

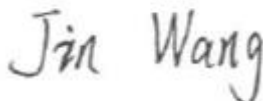

Jin Wang/ Technique principal

**Approved by:**



Gavin Liang/ Manager

## TEST REPORT

<b>Test Report No. :</b> <b>LCS211115092AEB</b>	December 02, 2021 ----- Date of issue
---	---

EUT.....	: Wireless Infrared Scouting Camera
Test Model.....	: UML3
<b>Applicant..... : Covert Scouting Cameras, LLC</b>	
Address.....	: 4338 Greenridge Spa Road,Lewisburg,KY 42256,US
Telephone.....	: /
Fax.....	: /
<b>Manufacturer..... : UOVision Technology (Shenzhen) Co., Ltd.</b>	
Address.....	: 5th and 6th Floor the first Building, shunheda Factory, liuxiandong Industrial Zone, xili Street, Nanshan District, Shenzhen, CHN 518055
Telephone.....	: /
Fax.....	: /
<b>Factory..... : UOVision Technology (Shenzhen) Co., Ltd.</b>	
Address.....	: 5th and 6th Floor the first Building, shunheda Factory, liuxiandong Industrial Zone, xili Street, Nanshan District, Shenzhen, CHN 518055
Telephone.....	: /
Fax.....	: /

<b>Test Result:</b>	<b>PASS</b>
---------------------	-------------

The test report merely corresponds to the test sample.  
It is not permitted to copy extracts of these test result without the written permission of the test laboratory.



## Revision History

Revision	Issue Date	Revisions	Revised By
000	December 02, 2021	Initial Issue	Gavin Liang



## Contents

<b>1</b>	<b>TEST STANDARDS .....</b>	<b>5</b>
<b>2</b>	<b>SUMMARY .....</b>	<b>6</b>
<b>2.1</b>	<b>General Remarks</b>	<b>6</b>
<b>2.2</b>	<b>Product Description</b>	<b>6</b>
<b>2.3</b>	<b>Equipment under Test</b>	<b>8</b>
<b>2.4</b>	<b>Short description of the Equipment under Test (EUT)</b>	<b>8</b>
<b>2.5</b>	<b>Internal Identification of AE used during the test</b>	<b>8</b>
<b>2.6</b>	<b>Normal Accessory setting</b>	<b>8</b>
<b>2.7</b>	<b>EUT configuration</b>	<b>9</b>
<b>2.8</b>	<b>Related Submittal(s) / Grant (s)</b>	<b>9</b>
<b>2.9</b>	<b>Modifications</b>	<b>9</b>
<b>2.10</b>	<b>General Test Conditions/Configurations</b>	<b>9</b>
<b>3</b>	<b>TEST ENVIRONMENT .....</b>	<b>10</b>
<b>3.1</b>	<b>Address of the test laboratory</b>	<b>10</b>
<b>3.2</b>	<b>Test Facility</b>	<b>10</b>
<b>3.3</b>	<b>Environmental conditions</b>	<b>10</b>
<b>3.4</b>	<b>Test Description</b>	<b>10</b>
<b>3.5</b>	<b>Equipments Used during the Test</b>	<b>15</b>
<b>3.6</b>	<b>Measurement uncertainty</b>	<b>16</b>
<b>4</b>	<b>TEST CONDITIONS AND RESULTS .....</b>	<b>17</b>
<b>4.1</b>	<b>Output Power</b>	<b>17</b>
<b>4.2</b>	<b>Peak-to-Average Ratio (PAR)</b>	<b>32</b>
<b>4.3</b>	<b>Occupied Bandwidth and Emission Bandwidth</b>	<b>33</b>
<b>4.4</b>	<b>Band Edge compliance</b>	<b>34</b>
<b>1.1</b>	<b>Spurious Emission on Antenna Port</b>	<b>36</b>
<b>4.5</b>	<b>Radiated Spurious Emission</b>	<b>38</b>
<b>4.6</b>	<b>Frequency Stability under Temperature &amp; Voltage Variations</b>	<b>48</b>
<b>5</b>	<b>TEST SETUP PHOTOS OF THE EUT .....</b>	<b>54</b>
<b>6</b>	<b>EXTERNAL PHOTOS OF THE EUT .....</b>	<b>54</b>
<b>7</b>	<b>INTERNAL PHOTOS OF THE EUT .....</b>	<b>54</b>



## **1 TEST STANDARDS**

The tests were performed according to following standards:

[FCC Part 22H](#): Cellular Radiotelephone Service

[FCC Part 24E](#): Broadband PCS

[FCC Part 27](#): MISCELLANEOUS WIRELESS COMMUNICATIONS SERVICES

[FCC Part 90](#): PRIVATE LAND MOBILE RADIO SERVICES

[TIA-603-E March 2016](#): Land Mobile FM or PM Communications Equipment Measurement and Performance Standards.

[47 CFR FCC Part 15 Subpart B](#): Unintentional Radiators

[FCC Part 2](#): FREQUENCY ALLOCATIONS AND RADIO TREATY MATTERS; GENERAL RULES AND REGULATIONS

[ANSI C63.4:2014](#): Methods of Measurement of Radio-Noise Emissions from Low-Voltage Electrical and Electronic Equipment in the Range of 9 kHz to 40 GHz

[FCC KDB971168 D01](#) Power Meas License Digital Systems v03r01

## 2 SUMMARY

### 2.1 General Remarks

Date of receipt of test sample	:	November 16, 2021
Date of Test	:	November 16, 2021 ~ November 30, 2021
Date of Report	:	December 02, 2021
Sample number	:	211115092A-1, 211115092A-2

### 2.2 Product Description

The **Covert Scouting Cameras, LLC**'s Model: UML3 or the "EUT" as referred to in this report; more general information as follows, for more details, refer to the user's manual of the EUT.

EUT	:	Wireless Infrared Scouting Camera
Test Model	:	UML3
Additional Model No.	:	Code Black Select
Model Declaration	:	PCB board, structure and internal of these model(s) are the same, So no additional models were tested
Power Supply	:	Input: DC 6V-12V Battery: 12*AA Batteries
Hardware Version	:	L3V50M
Software Version	:	DSP: JL3375; MCU: 18056.128.H
3G	:	
Support Band	:	<input checked="" type="checkbox"/> WCDMA Band II (U.S.-Band) <input checked="" type="checkbox"/> WCDMA Band V (U.S.-Band) <input checked="" type="checkbox"/> WCDMA Band IV (U.S.-Band) <input type="checkbox"/> WCDMA Band I (EU-Band) <input type="checkbox"/> WCDMA Band VIII (EU-Band)
Release Version	:	R9
Type Of Modulation	:	WCDMA: QPSK; HSDPA/HSUPA: QPSK
Antenna Description	:	External Antenna 3.0dBi (max.) For WCDMA Band II 3.0dBi (max.) For WCDMA Band IV 1.5dBi (max.) For WCDMA Band V
LTE	:	
Support Band	:	<input checked="" type="checkbox"/> E-UTRA Band 2(U.S.-Band) <input checked="" type="checkbox"/> E-UTRA Band 4(U.S.-Band) <input checked="" type="checkbox"/> E-UTRA Band 5(U.S.-Band) <input checked="" type="checkbox"/> E-UTRA Band 12(U.S.-Band) <input checked="" type="checkbox"/> E-UTRA Band 13(U.S.-Band) <input checked="" type="checkbox"/> E-UTRA Band 25(U.S.-Band) <input checked="" type="checkbox"/> E-UTRA Band 26(U.S.-Band)
LTE Release Version	:	R9
Type Of Modulation	:	QPSK/16QAM
Antenna Description	:	External Antenna 3.0dBi (max.) For E-UTRA Band 2



3.0dBi (max.) For E-UTRA Band 4  
1.5dBi (max.) For E-UTRA Band 5  
1.5dBi (max.) For E-UTRA Band 12  
1.5dBi (max.) For E-UTRA Band 13  
3.0dBi (max.) For E-UTRA Band 25  
1.5dBi (max.) For E-UTRA Band 26

Power Class : Class 3

GPS function : Support and only RX

Extreme temp. : -30°C to +50°C

Tolerance

Extreme vol. Limits : 5VDC to 7VDC (nominal: 6VDC)



## 2.3 Equipment under Test

### Power supply system utilised

Power supply voltage	:	<input type="radio"/> 120V / 60 Hz	<input type="radio"/> 115V / 60Hz
		<input type="radio"/> 12 V DC	<input type="radio"/> 24 V DC
		<input checked="" type="radio"/> Other (specified in blank below) 6V DC	

## 2.4 Short description of the Equipment under Test (EUT)

### 2.4.1 GeneralDescription

Wireless Infrared Scouting Camera is subscriber equipment in the WCDMA/LTE system. The HSPA/UMTS frequency band is Band II/IV/V. LTE frequency band is band 2/4/5/12/13/25/26. The HSPA/UMTS frequency band II and Band V test data included in this report. The Wireless Infrared Scouting Camera implements such functions as RF signal receiving/transmitting, HSPA/UMTS/LTE protocol processing, video MMS service and etc. Externally it provides SIM card interface.

## 2.5 Internal Identification of AE used during the test

AE ID*	Description
AE1	Rechargeable Li-Polymer Battery
AE2	Switching Adapter

## 2.6 Normal Accessory setting

Fully charged battery was used during the test.



## 2.7 EUT configuration

The following peripheral devices and interface cables were connected during the measurement:

- - supplied by the manufacturer
- - supplied by the lab

○	Power Cable	Length (m) :	/
		Shield :	/
		Detachable :	/
○	Multimeter	Manufacturer :	/
		Model No. :	/

## 2.8 Related Submittal(s) / Grant (s)

This submittal(s) (test report) is intended for **FCC ID: 2AUZZ-UML3** filing to comply with FCC Part 22, Part 24 , Part 27 Rules, Part 90 Rules

## 2.9 Modifications

No modifications were implemented to meet testing criteria.

## 2.10 General Test Conditions/Configurations

### 2.10.1 Test Environment

EnvironmentParameter	SelectedValuesDuringTests	
Relative Humidity	Ambient	
Temperature	TN	Ambient
Voltage	VL	DC 5V
	VN	DC 6V
	VH	DC 7V

NOTE:VL=lower extreme testvoltage VN=nominal voltage  
VH=upper extreme testvoltage TN=normal temperature



### 3 TEST ENVIRONMENT

#### 3.1 Address of the test laboratory

**Shenzhen LCS Compliance Testing Laboratory Ltd**

101, 201 Bldg A & 301 Bldg C, Juji Industrial Park Yabianxueziwei, Shajing Street, Baoan District, Shenzhen, 518000, China

The sites are constructed in conformance with the requirements of ANSI C63.4 (2014) and CISPR Publication 22.

#### 3.2 Test Facility

The test facility is recognized, certified, or accredited by the following organizations:

NVLAP Accreditation Code is 600167-0.

FCC Designation Number is CN5024.

CAB identifier is CN0071.

CNAS Registration Number is L4595.

Test Firm Registration Number: 254912

#### 3.3 Environmental conditions

During the measurement the environmental conditions were within the listed ranges:

Temperature:	15-35 ° C
Humidity:	30-60 %
Atmospheric pressure:	950-1050mbar

#### 3.4 Test Description

**Band 2 (1850-1910MHz pairedwith 1930-1990MHz)**

Test Item	FCC Rule No.	Requirements	Verdict
Effective(Isotropic) Radiated Output Power	§2.1046, §24.232	EIRP ≤ 2W	PASS
Peak-Average Ratio	§2.1046, §24.232	FCC:Limit≤13dB	PASS
Modulation Characteristics	§2.1047	Digital modulation	N/A
Bandwidth	§2.1049	OBW: No limit. EBW: No limit.	PASS
Band Edges Compliance	§2.1051, §24.238	≤ -13dBm/1%*EBW, In 1MHz bands immediately outside and adjacent to the frequency block.	PASS
Spurious Emission at Antenna Terminals	§2.1051, §24.238	≤-13dBm/1MHz, from 9kHz to10 <sup>th</sup> harmonics but outside authorized Operating frequency ranges.	PASS
Field Strength of Spurious Radiation	§2.1053, §24.238	≤ -13dBm/1MHz.	PASS
Frequency Stability	§2.1055, §24.235	FCC: within authorized frequency block.	PASS

NOTE 1:For the verdict, the“N/A”denotes“not applicable”,the“N/T”de notes “not tested”.

**Band 4 (1710-1755MHz pairedwith 2110-2155MHz)**

Test Item	FCC RuleNo.	Requirements	Verdict
Effective(Isotropic) Radiated Power Output Data	§2.1046, §27.50(d)	EIRP ≤ 1W;	PASS
Peak-Average Ratio	§2.1046, §27.50(d)	Limit≤13dB	Pass
Modulation Characteristics	§2.1047	Digitalmodulation	N/A
Bandwidth	§2.1049	OBW: Nolimit. EBW: Nolimit.	PASS
BandEdges Compliance	§2.1051, §27.53(h)	≤ -13dBm/1%*EBW,in1 MHz bands immediately outside and adjacent to the frequency block.	PASS
Spurious Emission at Antenna Terminals	§2.1051, §27.53(h)	≤ -13dBm/1MHz, from 9kHz to 10 <sup>th</sup> harmonics but outside authorized operating frequency ranges.	PASS
Frequency Stability	§2.1055, §27.54	Within authorized bands of operation/frequency block.	PASS
Radiated spurious emission	§2.1053, §27.53(h)	≤ -13dBm/1MHz.	PASS

NOTE 1: For the verdict, the “N/A” denotes “not applicable”, the “N/T” de notes “not tested”

**Band 5 (824-849MHz pairedwith 869-894MHz)**

Test Item	FCC Rule No.	Requirements	Verdict
Effective(Isotropic) Radiated Output Power	§2.1046, §22.913	FCC: ERP ≤ 7W.	Pass
Modulation Characteristics	§2.1047	Digital modulation	N/A
Bandwidth	§2.1049	OBW: No limit. EBW: No limit.	Pass
Band Edges Compliance	§2.1051, §22.917	≤-13dBm/1%*EBW, In 1MHz bands immediately outside and adjacent to The frequency block.	Pass
Spurious Emission at Antenna Terminals	§2.1051, §22.917	FCC: ≤ -13dBm/100kHz, from 9kHz to 10th harmonics but outside authorized operating frequency ranges.	Pass
Field Strength of Spurious Radiation	§2.1053, §22.917	FCC: ≤ -13dBm/100kHz.	Pass
Frequency Stability	§2.1055, §22.355	≤ ±2.5ppm.	Pass

NOTE 1:For the verdict, the“N/A”denotes“not applicable”,the“N/T”de notes “not tested”.

**Band 12 (699-716MHz paired with 729-746MHz)**

Test Item	FCC Rule No.	Requirements	Verdict
Effective(Isotropic) Radiated Power Output Data	§2.1046, §27.50(c)	ERP ≤ 3W;	PASS
Peak-Average Ratio	§2.1046, §27.50(c)	Limit≤13dB	PASS
Modulation Characteristics	§2.1047	Digitalmodulation	N/A
Bandwidth	§2.1049	OBW: Nolimit. EBW: Nolimit.	PASS
BandEdges Compliance	§2.1051, §27.53(g)	≤ -13dBm/1%*EBW,in1 MHz bands immediately outside and adjacent to The frequency block.	PASS
Spurious Emission at Antenna Terminals	§2.1051, §27.53(g)	≤ -13dBm/100KHz, from 9kHz to 10th harmonics but outside authorized Operating frequency ranges.	PASS
Frequency Stability	§2.1055, §27.54	Within authorized bands of operation/frequency block.	PASS
Radiatedspurious emission	§2.1053, §27.53(g)	≤ -13dBm/100KHz.	PASS
NOTE 1:For the verdict, the“N/A”denotes“not applicable”,the“N/T”de notes “not tested”.			

**Band 13 (777-787MHz paired with 746-756MHz)**

Test Item	FCC Rule No.	Requirements	Verdict
Effective(Isotropic) Radiated Power Output Data	§2.1046, §27.50(b)	ERP ≤ 3W;	PASS
Peak-Average Ratio	§2.1046, §27.50(b)	Limit≤13dB	PASS
Modulation Characteristics	§2.1047	Digitalmodulation	N/A
Bandwidth	§2.1049	OBW: Nolimit. EBW: Nolimit.	PASS
BandEdges Compliance	§2.1051, §27.53(c)	≤ -13dBm/1%*EBW,in1 MHz bands immediately outside and adjacent to The frequency block.	PASS
Spurious Emission at Antenna Terminals	§2.1051, §27.53(c)	≤ -13dBm/100KHz, from 9kHz to 10th harmonics but outside authorized Operating frequency ranges.	PASS
Frequency Stability	§2.1055, §27.54	Within authorized bands of operation/frequency block.	PASS
Radiatedspurious emission	§2.1053, §27.53(c)	≤ -13dBm/100KHz.	PASS
NOTE 1:For the verdict, the“N/A”denotes“not applicable”,the“N/T”de notes “not tested”.			

**Band 25(1850-1915MHz pairedwith 1930-1995MHz)**

Test Item	FCC Rule No.	Requirements	Verdict
Effective(Isotropic) Radiated Power Output Data	§2.1046, §24.232	ERP $\leq$ 2W;	PASS
Peak-Average Ratio	§2.1046, §24.232	Limit $\leq$ 13dB	PASS
Modulation Characteristics	§2.1047	Digitalmodulation	N/A
Bandwidth	§2.1049	OBW: Nolimit. EBW: Nolimit.	PASS
BandEdges Compliance	§2.1051, §24.238	$\leq$ -13dBm/1%*EBW, in1 MHz bands immediately outside and adjacent to The frequency block.	PASS
Spurious Emission at Antenna Terminals	§2.1051, §24.238	$\leq$ -13dBm/100KHz, from 9kHz to10th harmonics but outside authorized Operating frequency ranges.	PASS
Frequency Stability	§2.1053, §24.238	Within authorized bands of operation/frequency block.	PASS
Radiated spurious emission	§2.1055, §24.235	$\leq$ -13dBm/100KHz.	PASS

NOTE 1:For the verdict, the“N/A”denotes“not applicable”,the“N/T”de notes “not tested”.

**Band 26(814-824MHz pairedwith 859-869MHz)**

Test Item	FCC Rule No.	Requirements	Verdict
Effective(Isotropic) Radiated Power Output Data	§2.1046, §90.635	ERP $\leq$ 100W;	PASS
Peak-Average Ratio	§2.1046,	Limit $\leq$ 13dB	PASS
Modulation Characteristics	§2.1047	Digitalmodulation	N/A
Bandwidth	§2.1049	OBW: Nolimit. EBW: Nolimit.	PASS
BandEdges Compliance	§2.1051, §90.691	(a)(1) For any frequency removed from the EA licensee’s frequency blocok by up to and including 37.5 KHz, the power of any emission shall be attenuated below the transmitter power (P) in watts by at least 116 Log(f/6.1) decibels or 50 +10 Log10 (P) decibels or 80 decibels, whichever is lesser than attenuations, which f the frequency removed from the center of the outer channel in the blok in kilohertz and where f is greater than 12.5 KHz.	PASS
Spurious Emission at Antenna Terminals	§2.1051, §90.691	(a)(2) for any frequency removed from the EA licensee’s frequency block greater than 37.5 KHz, the power of any emission shall be attenuated below the transmitter power (P) in watts by at least 43 + 10Log10(P) decibels or 80 decibels, whichever is the lesser attenuationm where f is the frequency removed from the center of the outer channel in the block in kilohertz and where f is greater than 37.5 KHz. (Note: use 100 KHz reference bandwidth)	PASS
Frequency Stability	§2.1055, §90.213	$\leq$ $\pm$ 2.5ppm.	PASS
Radiated spurious emission	§2.1053, §90.669	$\leq$ -13dBm/100KHz.	PASS

NOTE 1:For the verdict, the“N/A”denotes“not applicable”,the“N/T”de notes “not tested”.

**Band 26(824-849MHz pairedwith 869-894MHz)**

Test Item	FCC Rule No.	Requirements	Verdict
Effective(Isotropic) Radiated Power Output Data	§2.1046, §22.913	ERP $\leq$ 7W;	PASS
Peak-Average Ratio	§2.1046,	Limit $\leq$ 13dB	PASS
Modulation Characteristics	§2.1047	Digitalmodulation	N/A
Bandwidth	§2.1049	OBW: Nolimit. EBW: Nolimit.	PASS
BandEdges Compliance	§2.1051, §22.917 §90.691	$\leq$ -13dBm/1%*EBW,in1 MHz bands immediately outside and adjacent to The frequency block.	PASS
Spurious Emission at Antenna Terminals	§2.1051, §22.917	$\leq$ -13dBm/100KHz, from 9kHz to10th harmonics but outside authorized Operating frequency ranges.	PASS
Frequency Stability	§2.1055, §22.355	$\leq$ $\pm$ 2.5ppm.	PASS
Radiated spurious emission	§2.1053, §22.917	$\leq$ -13dBm/100KHz.	PASS

NOTE 1:For the verdict, the“N/A”denotes“not applicable”,the“N/T”de notes “not tested”.



### 3.5 Equipments Used during the Test

Item	Equipment	Manufacturer	Model No.	Serial No.	Cal Date	Due Date
1	Power Meter	R&S	NRVS	100444	2021-06-21	2022-06-20
2	Power Sensor	R&S	NRV-Z81	100458	2021-06-21	2022-06-20
3	Power Sensor	R&S	NRV-Z32	10057	2021-06-21	2022-06-20
4	LTE Test Software	Tonscend	JS1120-1	N/A	N/A	N/A
5	RF Control Unit	Tonscend	JS0806	158060009	2021-11-25	2022-11-24
6	MXA Signal Analyzer	Agilent	N9020A	MY51250905	2021-11-16	2022-11-15
7	WIDEBAND RADIO COMMUNICATION TESTER	R&S	CMW 500	103818	2021-06-21	2022-06-20
8	DC Power Supply	Agilent	E3642A	N/A	2021-11-25	2022-11-24
9	EMI Test Software	AUDIX	E3	/	N/A	N/A
10	3m Semi Anechoic Chamber	SIDT FRANKONIA	SAC-3M	03CH03-HY	2021-06-21	2022-06-20
11	Positioning Controller	MF	MF7082	MF78020803	2021-06-21	2022-06-20
12	Active Loop Antenna	SCHWARZBECK	FMZB 1519B	00005	2021-07-25	2024-07-24
13	By-log Antenna	SCHWARZBECK	VULB9163	9163-470	2021-07-25	2024-07-24
14	Horn Antenna	SCHWARZBECK	BBHA 9120D	9120D-1925	2021-07-01	2024-06-30
15	Broadband Horn Antenna	SCHWARZBECK	BBHA 9170	791	2020-09-20	2023-09-19
16	Broadband Preamplifier	SCHWARZBECK	BBV9745	9719-025	2021-06-21	2022-06-20
17	EMI Test Receiver	R&S	ESR 7	101181	2021-06-21	2022-06-20
18	RS SPECTRUM ANALYZER	R&S	FSP40	100503	2021-11-16	2022-11-15
19	Broadband Preamplifier	/	BP-01M18G	P190501	2021-06-21	2022-06-20
20	6dB Attenuator	/	100W/6dB	1172040	2021-06-21	2022-06-20
21	3dB Attenuator	/	2N-3dB	/	2021-11-16	2022-11-15
22	Temperature & Humidity Chamber	GUANGZHOU GOGNWEN	GDS-100	70932	2021-10-07	2022-10-06
23	EMI Test Software	Farad	EZ	N/A	N/A	N/A



### 3.6 Measurement uncertainty

The data and results referenced in this document are true and accurate. The reader is cautioned that there may be errors within the calibration limits of the equipment and facilities. The measurement uncertainty was calculated for all measurements listed in this test report acc. to ETSI TR 100 028“Electromagnetic compatibility and Radio spectrum Matters (ERM);Uncertainties in the measurement of mobile radio equipment characteristics” and is documented in the Shenzhen LCS Compliance Testing Laboratory Ltd. quality system acc. to DIN EN ISO/IEC 17025. Furthermore, component and process variability of devices similar to that tested may result in additional deviation. The manufacturer has the sole responsibility of continued compliance of the device.

Hereafter the best measurement capability for Shenzhen LCS Compliance Testing Laboratory Ltd. is reported:

Test	Range	Measurement Uncertainty	Notes
Radiated Emission	30~1000MHz	3.10 dB	(1)
Radiated Emission	1~18GHz	3.80 dB	(1)
Radiated Emission	18-40GHz	3.90 dB	(1)
Conducted Disturbance	0.15~30MHz	1.63 dB	(1)
Conducted Power	9KHz~18GHz	0.61 dB	(1)
Spurious RF Conducted Emission	9KHz~40GHz	1.22 dB	(1)
Band Edge Compliance of RF Emission	9KHz~40GHz	1.22 dB	(1)
Occupied Bandwidth	9KHz~40GHz	-	(1)

(1) This uncertainty represents an expanded uncertainty expressed at approximately the 95% confidence level using a coverage factor of  $k=1.96$ .





## 4 TEST CONDITIONS AND RESULTS

### 4.1 Output Power

#### TEST APPLICABLE

During the process of testing, the EUT was controlled via R&S Digital Radio Communication tester (CMW 500) to ensure max power transmission and proper modulation. This result contains output power and EIRP measurements for the EUT. In all cases, output power is within the specified limits.

#### 4.1.1. Conducted Output Power

##### TEST CONFIGURATION

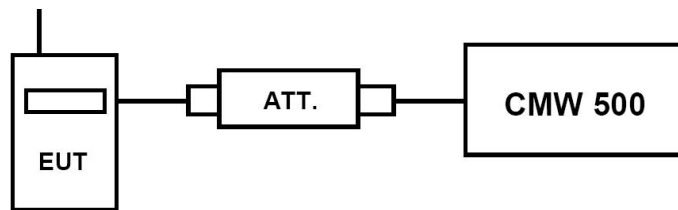

##### TEST PROCEDURE

###### **Conducted Power Measurement:**

- Place the EUT on a bench and set it in transmitting mode.
- Connect a low loss RF cable from the antenna port to a CMW 500 by an Att.
- EUT Communicate with CMW 500 then selects a channel for testing.
- Add a correction factor to the display CMW 500, and then test.

##### TEST RESULTS

###### *Remark:*

- We were tested all RB Configuration refer 3GPP TS136 521 for each Channel Bandwidth of LTE FDD Band 2, LTE FDD Band 4, LTE FDD Band 5, LTE FDD Band 12, LTE FDD Band 13, LTE FDD Band 25, LTE FDD Band 26; recorded worst case for each Channel Bandwidth of LTE FDD Band 2, LTE FDD Band 4, LTE FDD Band 5, LTE FDD Band 12, LTE FDD Band 13, LTE FDD Band 25, LTE FDD Band 26.
- For E-UTRA Band 2, please refer to Appendix A: Section A.1
- For E-UTRA Band 4, please refer to Appendix B: Section B.1
- For E-UTRA Band 5, please refer to Appendix C: Section C.1
- For E-UTRA Band 12, please refer to Appendix D: Section D.1
- For E-UTRA Band 13, please refer to Appendix E: Section E.1
- For E-UTRA Band 25, please refer to Appendix F: Section F.1
- For E-UTRA Band 26, please refer to Appendix G: Section G.1 & Appendix H: Section H.1

## 4.1.2. Radiated Output Power

### LIMIT

This is the test for the maximum radiated power from the EUT.

Per §22.913(2) Extend coverage on a secondary basis into cellular unserved areas, as those areas are defined in §22.949, the ERP of base transmitters and cellular repeaters of such systems must not exceed 1000 Watts. The ERP of mobile transmitters and auxiliary test transmitters must not exceed 7 Watts.

Rule Part 24.232(c) specifies, "Mobile/portable stations are limited to 2 watts e.i.r.p. Peak power" and 24.232(e) specifies that "Peak transmit power must be measured over any interval of continuous transmission using instrumentation calibrated in terms of an rms-equivalent voltage."

Per Part 27.50(d) (4) specifies, Fixed, mobile, and portable (hand-held) stations operating in the 1710-1755MHz band are limited to 1W EIRP. Fixed stations operating in this band are limited to a maximum antenna height of 10 meters above ground. Mobile and portable stations operating in this band must employ a means for limiting power to the minimum necessary for successful communications.

Per Part 27.50(c) (10) specifies, Portable stations (hand-held devices) in the 600 MHz uplink band and the 698-746 MHz band, and fixed and mobile stations in the 600 MHz uplink band are limited to 3 watts ERP.

Per Part 27.50(h) (2) specifies Mobile and other user stations. Mobile stations are limited to 2.0 watts EIRP. All user stations are limited to 2.0 watts transmitter output power.

Per Part 90.635(b) The maximum output power of the transmitter for mobile stations is 100 watts (20 dBw).

### TEST CONFIGURATION

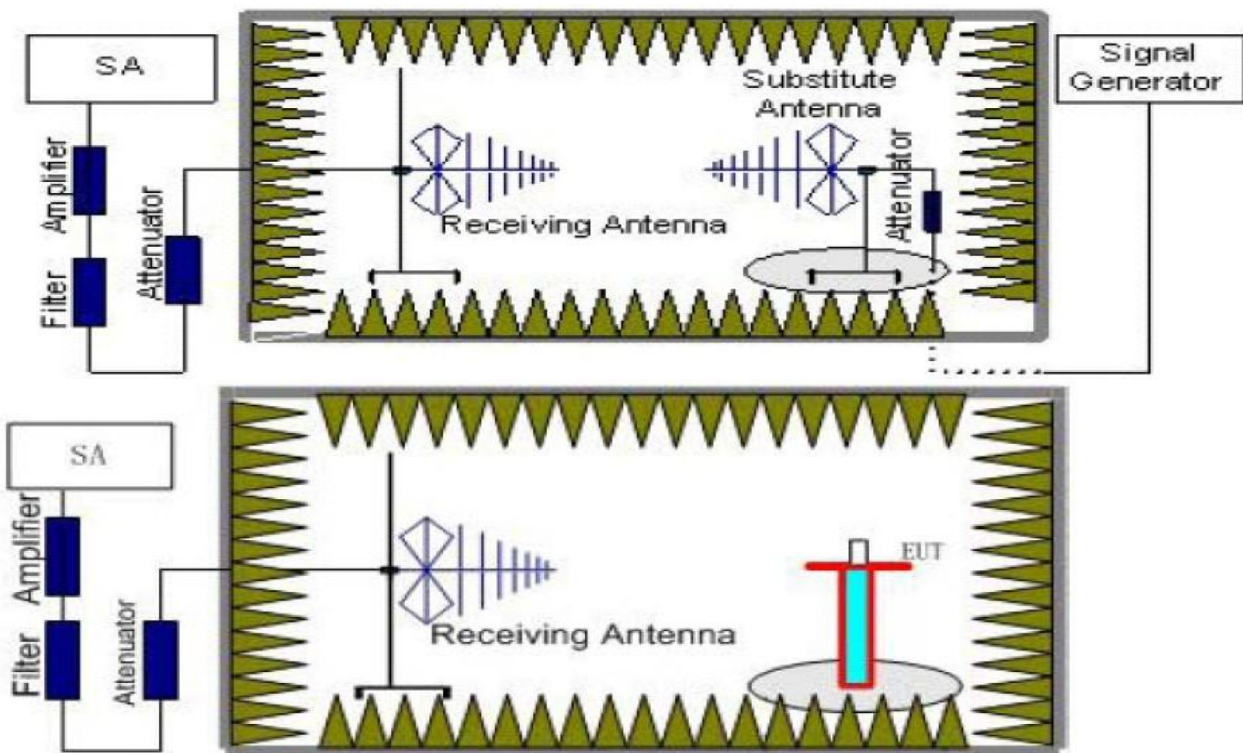

### TEST PROCEDURE

1. EUT was placed on a 1.50 meter high non-conductive stand at a 3 meter test distance from the receive antenna. A receiving antenna was placed on the antenna mast 3 meters from the EUT for emission measurements. The height of receiving antenna is 1.50m. Detected emissions were maximized at each frequency by rotating the EUT through 360° and adjusting the receiving antenna polarization. The radiated emission measurements of all transmit frequencies in three channels (High, Middle, Low) were measured with peak detector.
2. A log-periodic antenna or double-ridged waveguide horn antenna shall be substituted in place of the EUT. The log-periodic antenna will be driven by a signal generator and the level will be adjusted till the same power value on the spectrum analyzer or receiver. The level of the spurious emissions can be calculated through the level of the signal generator, cable loss, the gain of the substitution antenna and the reading of the spectrum analyzer or receiver.



3. The EUT is then put into continuously transmitting mode at its maximum power level during the test. Set Test Receiver or Spectrum RBW=1MHz, VBW=3MHz, And the maximum value of the receiver should be recorded as ( $P_r$ ).
4. The EUT shall be replaced by a substitution antenna. In the chamber, an substitution antenna for the frequency band of interest is placed at the reference point of the chamber. An RF Signal source for the frequency band of interest is connected to the substitution antenna with a cable that has been constructed to not interfere with the radiation pattern of the antenna. A power ( $P_{Mea}$ ) is applied to the input of the substitution antenna, and adjust the level of the signal generator output until the value of the receiver reach the previously recorded ( $P_r$ ). The power of signal source ( $P_{Mea}$ ) is recorded. The test should be performed by rotating the test item and adjusting the receiving antenna polarization.
5. A amplifier should be connected to the Signal Source output port. And the cable should be connect between the Amplifier and the Substitution Antenna. The cable loss ( $P_{cl}$ ), the Substitution Antenna Gain ( $G_a$ ) and the Amplifier Gain ( $P_{Ag}$ ) should be recorded after test.  
The measurement results are obtained as described below:  
$$\text{Power(EIRP)} = P_{Mea} + P_{Ag} - P_{cl} + G_a$$
6. This value is EIRP since the measurement is calibrated using an antenna of known gain (2.15 dBi) and known input power.
7. ERP can be calculated from EIRP by subtracting the gain of the dipole,  $ERP = EIRP - 2.15\text{dBi}$ .

## **TEST RESULTS**

### **Radiated Measurement:**

Remark:

1. We were tested all RB Configuration refer 3GPP TS136 521 for each Channel Bandwidth of LTE FDD Band 2, LTE FDD Band 4, LTE FDD Band 5, LTE FDD Band 12, LTE FDD Band 13, LTE FDD Band 25, LTE FDD Band 26; recorded worst case for each Channel Bandwidth of LTE FDD Band 2, LTE FDD Band 4, LTE FDD Band 5, LTE FDD Band 12, LTE FDD Band 13, LTE FDD Band 25, LTE FDD Band 26.
2.  $EIRP = P_{Mea}(dBm) - P_{cl}(dB) + P_{Ag}(dB) + G_a(dBi)$
3.  $ERP = EIRP - 2.15\text{dBi}$  as EIRP by subtracting the gain of the dipole.
4. Margin = Emission Level – Limit
5. We test the H direction and V direction but only recorded the worst case V direction in this report.

*LTE FDD Band 2 Channel Bandwidth 1.4MHz QPSK*

Frequency (MHz)	P <sub>Mea</sub> (dBm)	P <sub>cl</sub> (dB)	G <sub>a</sub> Antenna Gain(dB)	P <sub>Ag</sub> (dB)	Burst Average EIRP (dBm)	Limit (dBm)	Margin (dB)	Polarization
1850.7	-19.91	4.03	8.38	35.51	19.95	33.01	-13.06	V
1880.0	-19.49	4.08	8.33	35.56	20.32	33.01	-12.69	V
1909.3	-19.42	4.14	8.26	35.63	20.33	33.01	-12.68	V

*LTE FDD Band 2 Channel Bandwidth 3MHz QPSK*

Frequency (MHz)	P <sub>Mea</sub> (dBm)	P <sub>cl</sub> (dB)	G <sub>a</sub> Antenna Gain(dB)	P <sub>Ag</sub> (dB)	Burst Average EIRP (dBm)	Limit (dBm)	Margin (dB)	Polarization
1851.5	-19.72	4.03	8.38	35.51	20.14	33.01	-12.87	V
1880.0	-19.81	4.08	8.33	35.56	20.00	33.01	-13.01	V
1908.5	-20.45	4.14	8.26	35.63	19.30	33.01	-13.71	V

*LTE FDD Band 2 Channel Bandwidth 5MHz QPSK*

Frequency (MHz)	P <sub>Mea</sub> (dBm)	P <sub>cl</sub> (dB)	G <sub>a</sub> Antenna Gain(dB)	P <sub>Ag</sub> (dB)	Burst Average EIRP (dBm)	Limit (dBm)	Margin (dB)	Polarization
1852.5	-20.44	4.03	8.38	35.51	19.42	33.01	-13.59	V
1880.0	-20.55	4.08	8.33	35.56	19.26	33.01	-13.75	V
1907.5	-20.53	4.14	8.26	35.63	19.22	33.01	-13.79	V

*LTE FDD Band 2 Channel Bandwidth 10MHz QPSK*

Frequency (MHz)	P <sub>Mea</sub> (dBm)	P <sub>cl</sub> (dB)	G <sub>a</sub> Antenna Gain(dB)	P <sub>Ag</sub> (dB)	Burst Average EIRP (dBm)	Limit (dBm)	Margin (dB)	Polarization
1855.0	-20.77	4.03	8.38	35.51	19.09	33.01	-13.92	V
1880.0	-21.31	4.08	8.33	35.56	18.50	33.01	-14.51	V
1905.0	-21.14	4.14	8.26	35.63	18.61	33.01	-14.40	V

*LTE FDD Band 2 Channel Bandwidth 15MHz QPSK*

Frequency (MHz)	P <sub>Mea</sub> (dBm)	P <sub>cl</sub> (dB)	G <sub>a</sub> Antenna Gain(dB)	P <sub>Ag</sub> (dB)	Burst Average EIRP (dBm)	Limit (dBm)	Margin (dB)	Polarization
1857.5	-21.88	4.03	8.38	35.51	17.98	33.01	-15.03	V
1880.0	-21.04	4.08	8.33	35.56	18.77	33.01	-14.24	V
1902.5	-21.65	4.14	8.26	35.63	18.10	33.01	-14.91	V

*LTE FDD Band 2 Channel Bandwidth 20MHz QPSK*

Frequency (MHz)	P <sub>Mea</sub> (dBm)	P <sub>cl</sub> (dB)	G <sub>a</sub> Antenna Gain(dB)	P <sub>Ag</sub> (dB)	Burst Average EIRP (dBm)	Limit (dBm)	Margin (dB)	Polarization
1860.0	-21.50	4.03	8.38	35.51	18.36	33.01	-14.65	V
1880.0	-21.73	4.08	8.33	35.56	18.08	33.01	-14.93	V
1900.0	-22.05	4.14	8.26	35.63	17.70	33.01	-15.31	V

*LTE FDD Band 2 Channel Bandwidth 1.4MHz 16QAM*

Frequency (MHz)	P <sub>Mea</sub> (dBm)	P <sub>cl</sub> (dB)	G <sub>a</sub> Antenna Gain(dB)	P <sub>Ag</sub> (dB)	Burst Average EIRP (dBm)	Limit (dBm)	Margin (dB)	Polarization
1850.7	-19.97	4.03	8.38	35.51	19.89	33.01	-13.12	V
1880.0	-20.05	4.08	8.33	35.56	19.76	33.01	-13.25	V
1909.3	-20.15	4.14	8.26	35.63	19.60	33.01	-13.41	V

*LTE FDD Band 2 Channel Bandwidth 3MHz 16QAM*

Frequency (MHz)	P <sub>Mea</sub> (dBm)	P <sub>cl</sub> (dB)	G <sub>a</sub> Antenna Gain(dB)	P <sub>Ag</sub> (dB)	Burst Average EIRP (dBm)	Limit (dBm)	Margin (dB)	Polarization
1851.5	-20.56	4.03	8.38	35.51	19.30	33.01	-13.71	V
1880.0	-20.99	4.08	8.33	35.56	18.82	33.01	-14.19	V
1908.5	-20.97	4.14	8.26	35.63	18.78	33.01	-14.23	V

*LTE FDD Band 2 Channel Bandwidth 5MHz 16QAM*

Frequency (MHz)	P <sub>Mea</sub> (dBm)	P <sub>cl</sub> (dB)	G <sub>a</sub> Antenna Gain(dB)	P <sub>Ag</sub> (dB)	Burst Average EIRP (dBm)	Limit (dBm)	Margin (dB)	Polarization
1852.5	-20.52	4.03	8.38	35.51	19.34	33.01	-13.67	V
1880.0	-21.42	4.08	8.33	35.56	18.39	33.01	-14.62	V
1907.5	-21.04	4.14	8.26	35.63	18.71	33.01	-14.30	V

*LTE FDD Band 2 Channel Bandwidth 10MHz 16QAM*

Frequency (MHz)	P <sub>Mea</sub> (dBm)	P <sub>cl</sub> (dB)	G <sub>a</sub> Antenna Gain(dB)	P <sub>Ag</sub> (dB)	Burst Average EIRP (dBm)	Limit (dBm)	Margin (dB)	Polarization
1855.0	-21.99	4.03	8.38	35.51	17.87	33.01	-15.14	V
1880.0	-21.52	4.08	8.33	35.56	18.29	33.01	-14.72	V
1905.0	-21.79	4.14	8.26	35.63	17.96	33.01	-15.05	V

*LTE FDD Band 2 Channel Bandwidth 15MHz 16QAM*

Frequency (MHz)	P <sub>Mea</sub> (dBm)	P <sub>cl</sub> (dB)	G <sub>a</sub> Antenna Gain(dB)	P <sub>Ag</sub> (dB)	Burst Average EIRP (dBm)	Limit (dBm)	Margin (dB)	Polarization
1857.5	-21.95	4.03	8.38	35.51	17.91	33.01	-15.10	V
1880.0	-21.90	4.08	8.33	35.56	17.91	33.01	-15.10	V
1902.5	-22.00	4.14	8.26	35.63	17.75	33.01	-15.26	V

*LTE FDD Band 2 Channel Bandwidth 20MHz 16QAM*

Frequency (MHz)	P <sub>Mea</sub> (dBm)	P <sub>cl</sub> (dB)	G <sub>a</sub> Antenna Gain(dB)	P <sub>Ag</sub> (dB)	Burst Average EIRP (dBm)	Limit (dBm)	Margin (dB)	Polarization
1860.0	-22.99	4.03	8.38	35.51	16.87	33.01	-16.14	V
1880.0	-22.84	4.08	8.33	35.56	16.97	33.01	-16.04	V
1900.0	-22.06	4.14	8.26	35.63	17.69	33.01	-15.32	V

*LTE FDD Band 4 Channel Bandwidth 1.4MHz QPSK*

Frequency (MHz)	P <sub>Mea</sub> (dBm)	P <sub>cl</sub> (dB)	G <sub>a</sub> Antenna Gain(dB)	P <sub>Ag</sub> (dB)	Burst Average EIRP (dBm)	Limit (dBm)	Margin (dB)	Polarization
1710.7	-19.36	3.93	9.05	34.96	20.72	30.00	-9.28	V
1732.5	-19.49	3.93	8.89	35.01	20.48	30.00	-9.52	V
1754.3	-19.07	3.94	8.76	35.08	20.83	30.00	-9.17	V

*LTE FDD Band 4 Channel Bandwidth 3MHz QPSK*

Frequency (MHz)	P <sub>Mea</sub> (dBm)	P <sub>cl</sub> (dB)	G <sub>a</sub> Antenna Gain(dB)	P <sub>Ag</sub> (dB)	Burst Average EIRP (dBm)	Limit (dBm)	Margin (dB)	Polarization
1711.5	-19.44	3.93	9.05	34.96	20.64	30.00	-9.36	V
1732.5	-18.98	3.93	8.89	35.01	20.99	30.00	-9.01	V
1753.5	-19.80	3.94	8.76	35.08	20.10	30.00	-9.90	V

*LTE FDD Band 4 Channel Bandwidth 5MHz QPSK*

Frequency (MHz)	P <sub>Mea</sub> (dBm)	P <sub>cl</sub> (dB)	G <sub>a</sub> Antenna Gain(dB)	P <sub>Ag</sub> (dB)	Burst Average EIRP (dBm)	Limit (dBm)	Margin (dB)	Polarization
1712.5	-18.78	3.93	9.05	34.96	21.30	30.00	-8.70	V
1732.5	-18.96	3.93	8.89	35.01	21.01	30.00	-8.99	V
1752.5	-19.08	3.94	8.76	35.08	20.82	30.00	-9.18	V

*LTE FDD Band 4 Channel Bandwidth 10MHz QPSK*

Frequency (MHz)	P <sub>Mea</sub> (dBm)	P <sub>cl</sub> (dB)	G <sub>a</sub> Antenna Gain(dB)	P <sub>Ag</sub> (dB)	Burst Average EIRP (dBm)	Limit (dBm)	Margin (dB)	Polarization
1715.0	-19.62	3.93	9.05	34.96	20.46	30.00	-9.54	V
1732.5	-19.13	3.93	8.89	35.01	20.84	30.00	-9.16	V
1750.0	-19.72	3.94	8.76	35.08	20.18	30.00	-9.82	V

*LTE FDD Band 4 Channel Bandwidth 15MHz QPSK*

Frequency (MHz)	P <sub>Mea</sub> (dBm)	P <sub>cl</sub> (dB)	G <sub>a</sub> Antenna Gain(dB)	P <sub>Ag</sub> (dB)	Burst Average EIRP (dBm)	Limit (dBm)	Margin (dB)	Polarization
1717.5	-19.31	3.93	9.05	34.96	20.77	30.00	-9.23	V
1732.5	-18.73	3.93	8.89	35.01	21.24	30.00	-8.76	V
1747.5	-18.82	3.94	8.76	35.08	21.08	30.00	-8.92	V

*LTE FDD Band 4 Channel Bandwidth 20MHz QPSK*

Frequency (MHz)	P <sub>Mea</sub> (dBm)	P <sub>cl</sub> (dB)	G <sub>a</sub> Antenna Gain(dB)	P <sub>Ag</sub> (dB)	Burst Average EIRP (dBm)	Limit (dBm)	Margin (dB)	Polarization
1720.0	-19.07	3.93	9.05	34.96	21.01	30.00	-8.99	V
1732.5	-19.21	3.93	8.89	35.01	20.76	30.00	-9.24	V
1745.0	-19.16	3.94	8.76	35.08	20.74	30.00	-9.26	V

*LTE FDD Band 4 Channel Bandwidth 1.4MHz 16QAM*

Frequency (MHz)	P <sub>Mea</sub> (dBm)	P <sub>cl</sub> (dB)	G <sub>a</sub> Antenna Gain(dB)	P <sub>Ag</sub> (dB)	Burst Average EIRP (dBm)	Limit (dBm)	Margin (dB)	Polarization
1710.7	-18.96	3.93	9.05	34.96	21.12	30.00	-8.88	V
1732.5	-19.51	3.93	8.89	35.01	20.46	30.00	-9.54	V
1754.3	-19.20	3.94	8.76	35.08	20.70	30.00	-9.30	V

*LTE FDD Band 4 Channel Bandwidth 3MHz 16QAM*

Frequency (MHz)	P <sub>Mea</sub> (dBm)	P <sub>cl</sub> (dB)	G <sub>a</sub> Antenna Gain(dB)	P <sub>Ag</sub> (dB)	Burst Average EIRP (dBm)	Limit (dBm)	Margin (dB)	Polarization
1711.5	-19.11	3.93	9.05	34.96	20.97	30.00	-9.03	V
1732.5	-19.43	3.93	8.89	35.01	20.54	30.00	-9.46	V
1753.5	-19.05	3.94	8.76	35.08	20.85	30.00	-9.15	V

*LTE FDD Band 4 Channel Bandwidth 5MHz 16QAM*

Frequency (MHz)	P <sub>Mea</sub> (dBm)	P <sub>cl</sub> (dB)	G <sub>a</sub> Antenna Gain(dB)	P <sub>Ag</sub> (dB)	Burst Average EIRP (dBm)	Limit (dBm)	Margin (dB)	Polarization
1712.5	-19.33	3.93	9.05	34.96	20.75	30.00	-9.25	V
1732.5	-19.87	3.93	8.89	35.01	20.10	30.00	-9.90	V
1752.5	-19.50	3.94	8.76	35.08	20.40	30.00	-9.60	V

*LTE FDD Band 4 Channel Bandwidth 10MHz 16QAM*

Frequency (MHz)	P <sub>Mea</sub> (dBm)	P <sub>cl</sub> (dB)	G <sub>a</sub> Antenna Gain(dB)	P <sub>Ag</sub> (dB)	Burst Average EIRP (dBm)	Limit (dBm)	Margin (dB)	Polarization
1715.0	-18.92	3.93	9.05	34.96	21.16	30.00	-8.84	V
1732.5	-18.78	3.93	8.89	35.01	21.19	30.00	-8.81	V
1750.0	-19.11	3.94	8.76	35.08	20.79	30.00	-9.21	V

*LTE FDD Band 4 Channel Bandwidth 15MHz 16QAM*

Frequency (MHz)	P <sub>Mea</sub> (dBm)	P <sub>cl</sub> (dB)	G <sub>a</sub> Antenna Gain(dB)	P <sub>Ag</sub> (dB)	Burst Average EIRP (dBm)	Limit (dBm)	Margin (dB)	Polarization
1717.5	-19.52	3.93	9.05	34.96	20.56	30.00	-9.44	V
1732.5	-19.14	3.93	8.89	35.01	20.83	30.00	-9.17	V
1747.5	-19.44	3.94	8.76	35.08	20.46	30.00	-9.54	V

*LTE FDD Band 4 Channel Bandwidth 20MHz 16QAM*

Frequency (MHz)	P <sub>Mea</sub> (dBm)	P <sub>cl</sub> (dB)	G <sub>a</sub> Antenna Gain(dB)	P <sub>Ag</sub> (dB)	Burst Average EIRP (dBm)	Limit (dBm)	Margin (dB)	Polarization
1720.0	-19.21	3.93	9.05	34.96	20.87	30.00	-9.13	V
1732.5	-18.67	3.93	8.89	35.01	21.30	30.00	-8.70	V
1745.0	-18.92	3.94	8.76	35.08	20.98	30.00	-9.02	V

*LTE FDD Band 5 Channel Bandwidth 1.4MHz QPSK*

Frequency (MHz)	P <sub>Mea</sub> (dBm)	P <sub>cl</sub> (dB)	G <sub>a</sub> Antenna Gain(dB)	Correction (dB)	P <sub>Ag</sub> (dB)	Peak ERP (dBm)	Limit (dBm)	Margin (dB)	Polarization
824.70	-15.76	3.45	8.45	2.15	33.79	20.88	38.45	-17.57	V
836.50	-15.94	3.49	8.45	2.15	33.85	20.72	38.45	-17.73	V
848.30	-16.04	3.55	8.36	2.15	33.88	20.50	38.45	-17.95	V

*LTE FDD Band 5 Channel Bandwidth 3MHz QPSK*

Frequency (MHz)	P <sub>Mea</sub> (dBm)	P <sub>cl</sub> (dB)	G <sub>a</sub> Antenna Gain(dB)	Correction (dB)	P <sub>Ag</sub> (dB)	Peak ERP (dBm)	Limit (dBm)	Margin (dB)	Polarization
825.50	-16.08	3.45	8.45	2.15	33.79	20.56	38.45	-17.89	V
836.50	-15.90	3.49	8.45	2.15	33.85	20.76	38.45	-17.69	V
847.50	-16.05	3.55	8.36	2.15	33.88	20.49	38.45	-17.96	V

*LTE FDD Band 5 Channel Bandwidth 5MHz QPSK*

Frequency (MHz)	P <sub>Mea</sub> (dBm)	P <sub>cl</sub> (dB)	G <sub>a</sub> Antenna Gain(dB)	Correction (dB)	P <sub>Ag</sub> (dB)	Peak ERP (dBm)	Limit (dBm)	Margin (dB)	Polarization
826.50	-16.25	3.45	8.45	2.15	33.79	20.39	38.45	-18.06	V
836.50	-15.99	3.49	8.45	2.15	33.85	20.67	38.45	-17.78	V
846.50	-15.69	3.55	8.36	2.15	33.88	20.85	38.45	-17.60	V

*LTE FDD Band 5 Channel Bandwidth 10MHz QPSK*

Frequency (MHz)	P <sub>Mea</sub> (dBm)	P <sub>cl</sub> (dB)	G <sub>a</sub> Antenna Gain(dB)	Correction (dB)	P <sub>Ag</sub> (dB)	Peak ERP (dBm)	Limit (dBm)	Margin (dB)	Polarization
829.00	-15.78	3.45	8.45	2.15	33.79	20.86	38.45	-17.59	V
836.50	-16.26	3.49	8.45	2.15	33.85	20.40	38.45	-18.05	V
844.00	-16.24	3.55	8.36	2.15	33.88	20.30	38.45	-18.15	V

*LTE FDD Band 5 Channel Bandwidth 1.4MHz 16QAM*

Frequency (MHz)	P <sub>Mea</sub> (dBm)	P <sub>cl</sub> (dB)	G <sub>a</sub> Antenna Gain(dB)	Correction (dB)	P <sub>Ag</sub> (dB)	Peak ERP (dBm)	Limit (dBm)	Margin (dB)	Polarization
824.70	-17.34	3.45	8.45	2.15	33.79	19.30	38.45	-19.15	V
836.50	-16.50	3.49	8.45	2.15	33.85	20.16	38.45	-18.29	V
848.30	-16.77	3.55	8.36	2.15	33.88	19.77	38.45	-18.68	V

*LTE FDD Band 5 Channel Bandwidth 3MHz 16QAM*

Frequency (MHz)	P <sub>Mea</sub> (dBm)	P <sub>cl</sub> (dB)	G <sub>a</sub> Antenna Gain(dB)	Correction (dB)	P <sub>Ag</sub> (dB)	Peak ERP (dBm)	Limit (dBm)	Margin (dB)	Polarization
825.50	-17.29	3.45	8.45	2.15	33.79	19.35	38.45	-19.10	V
836.50	-16.71	3.49	8.45	2.15	33.85	19.95	38.45	-18.50	V
847.50	-16.75	3.55	8.36	2.15	33.88	19.79	38.45	-18.66	V

*LTE FDD Band 5 Channel Bandwidth 5MHz 16QAM*

Frequency (MHz)	P <sub>Mea</sub> (dBm)	P <sub>cl</sub> (dB)	G <sub>a</sub> Antenna Gain(dB)	Correction (dB)	P <sub>Ag</sub> (dB)	Peak ERP (dBm)	Limit (dBm)	Margin (dB)	Polarization
826.50	-17.08	3.45	8.45	2.15	33.79	19.56	38.45	-18.89	V
836.50	-17.16	3.49	8.45	2.15	33.85	19.50	38.45	-18.95	V
846.50	-16.87	3.55	8.36	2.15	33.88	19.67	38.45	-18.78	V



*LTE FDD Band 5 Channel Bandwidth 10MHz 16QAM*

Frequency (MHz)	P <sub>Mea</sub> (dBm)	P <sub>cl</sub> (dB)	G <sub>a</sub> Antenna Gain (dB)	Correction (dB)	P <sub>Ag</sub> (dB)	Peak ERP (dBm)	Limit (dBm)	Margin (dB)	Polarization
829.00	-17.33	3.45	8.45	2.15	33.79	19.31	38.45	-19.14	V
836.50	-16.60	3.49	8.45	2.15	33.85	20.06	38.45	-18.39	V
844.00	-17.33	3.55	8.36	2.15	33.88	19.21	38.45	-19.24	V

*LTE FDD Band 12 Channel Bandwidth 1.4MHz QPSK*

Frequency (MHz)	P <sub>Mea</sub> (dBm)	P <sub>cl</sub> (dB)	G <sub>a</sub> Antenna Gain (dB)	P <sub>Ag</sub> (dB)	Correction (dB)	Burst Avergae ERP (dBm)	Limit (dBm)	Margin (dB)	Polarization
699.70	-14.93	3.01	8.29	2.15	33.52	21.72	34.77	-13.05	V
707.50	-14.38	3.02	8.29	2.15	33.52	22.26	34.77	-12.51	V
715.30	-14.68	3.06	8.29	2.15	33.52	21.92	34.77	-12.85	V

*LTE FDD Band 12 Channel Bandwidth 3MHz QPSK*

Frequency (MHz)	P <sub>Mea</sub> (dBm)	P <sub>cl</sub> (dB)	G <sub>a</sub> Antenna Gain (dB)	P <sub>Ag</sub> (dB)	Correction (dB)	Burst Avergae ERP (dBm)	Limit (dBm)	Margin (dB)	Polarization
700.50	-14.52	3.01	8.29	2.15	33.52	22.13	34.77	-12.64	V
707.50	-15.22	3.02	8.29	2.15	33.52	21.42	34.77	-13.35	V
714.50	-14.67	3.06	8.29	2.15	33.52	21.93	34.77	-12.84	V

*LTE FDD Band 12 Channel Bandwidth 5MHz QPSK*

Frequency (MHz)	P <sub>Mea</sub> (dBm)	P <sub>cl</sub> (dB)	G <sub>a</sub> Antenna Gain (dB)	P <sub>Ag</sub> (dB)	Correction (dB)	Burst Avergae ERP (dBm)	Limit (dBm)	Margin (dB)	Polarization
701.50	-15.66	3.01	8.29	2.15	33.52	20.99	34.77	-13.78	V
707.50	-15.03	3.02	8.29	2.15	33.52	21.61	34.77	-13.16	V
713.50	-15.43	3.06	8.29	2.15	33.52	21.17	34.77	-13.60	V

*LTE FDD Band 12 Channel Bandwidth 10MHz QPSK*

Frequency (MHz)	P <sub>Mea</sub> (dBm)	P <sub>cl</sub> (dB)	G <sub>a</sub> Antenna Gain (dB)	P <sub>Ag</sub> (dB)	Correction (dB)	Burst Avergae ERP (dBm)	Limit (dBm)	Margin (dB)	Polarization
704.00	-15.56	3.01	8.29	2.15	33.52	21.09	34.77	-13.68	V
707.50	-16.17	3.02	8.29	2.15	33.52	20.47	34.77	-14.30	V
711.00	-15.53	3.06	8.29	2.15	33.52	21.07	34.77	-13.70	V

*LTE FDD Band 12 Channel Bandwidth 1.4MHz 16QAM*

Frequency (MHz)	P <sub>Mea</sub> (dBm)	P <sub>cl</sub> (dB)	G <sub>a</sub> Antenna Gain (dB)	P <sub>Ag</sub> (dB)	Correction (dB)	Burst Avergae ERP (dBm)	Limit (dBm)	Margin (dB)	Polarization
699.70	-15.08	3.01	8.29	2.15	33.52	21.57	34.77	-13.20	V
707.50	-14.71	3.02	8.29	2.15	33.52	21.93	34.77	-12.84	V
715.30	-15.20	3.06	8.29	2.15	33.52	21.40	34.77	-13.37	V

*LTE FDD Band 12 Channel Bandwidth 3MHz 16QAM*

Frequency (MHz)	P <sub>Mea</sub> (dBm)	P <sub>cl</sub> (dB)	G <sub>a</sub> Antenna Gain (dB)	P <sub>Ag</sub> (dB)	Correction (dB)	Burst Avergae ERP (dBm)	Limit (dBm)	Margin (dB)	Polarization
700.50	-15.65	3.01	8.29	2.15	33.52	21.00	34.77	-13.77	V
707.50	-15.16	3.02	8.29	2.15	33.52	21.48	34.77	-13.29	V
714.50	-15.25	3.06	8.29	2.15	33.52	21.35	34.77	-13.42	V

*LTE FDD Band 12 Channel Bandwidth 5MHz 16QAM*

Frequency (MHz)	P <sub>Mea</sub> (dBm)	P <sub>cl</sub> (dB)	G <sub>a</sub> Antenna Gain (dB)	P <sub>Ag</sub> (dB)	Correction (dB)	Burst Avergae ERP (dBm)	Limit (dBm)	Margin (dB)	Polarization
701.50	-15.97	3.01	8.29	2.15	33.52	20.68	34.77	-14.09	V
707.50	-16.44	3.02	8.29	2.15	33.52	20.20	34.77	-14.57	V
713.50	-16.20	3.06	8.29	2.15	33.52	20.40	34.77	-14.37	V

*LTE FDD Band 12 Channel Bandwidth 10MHz 16QAM*

Frequency (MHz)	P <sub>Mea</sub> (dBm)	P <sub>cl</sub> (dB)	G <sub>a</sub> Antenna Gain (dB)	P <sub>Ag</sub> (dB)	Correction (dB)	Burst Avergae ERP (dBm)	Limit (dBm)	Margin (dB)	Polarization
704.00	-16.15	3.01	8.29	2.15	33.52	20.50	34.77	-14.27	V
707.50	-16.91	3.02	8.29	2.15	33.52	19.73	34.77	-15.04	V
711.00	-16.92	3.06	8.29	2.15	33.52	19.68	34.77	-15.09	V

*LTE FDD Band 13 Channel Bandwidth 5MHz QPSK*

Frequency (MHz)	P <sub>Mea</sub> (dBm)	P <sub>cl</sub> (dB)	G <sub>a</sub> Antenna Gain(dB)	P <sub>Ag</sub> (dB)	Correction (dB)	ERP (dBm)	Limit (dBm)	Margin (dB)	Polarization
779.5	-17.89	3.21	9.61	33.89	2.15	20.25	34.77	-14.52	V
782.0	-18.20	3.23	9.52	34.74	2.15	20.68	34.77	-14.09	V
784.5	-18.47	3.25	9.43	34.85	2.15	20.41	34.77	-14.36	V

*LTE FDD Band 13 Channel Bandwidth 10MHz QPSK*

Frequency (MHz)	P <sub>Mea</sub> (dBm)	P <sub>cl</sub> (dB)	G <sub>a</sub> Antenna Gain(dB)	P <sub>Ag</sub> (dB)	Correction (dB)	ERP (dBm)	Limit (dBm)	Margin (dB)	Polarization
782.0	-16.58	3.23	9.52	34.74	2.15	22.30	34.77	-12.47	V

*LTE FDD Band 13 Channel Bandwidth 5MHz 16QAM*

Frequency (MHz)	P <sub>Mea</sub> (dBm)	P <sub>cl</sub> (dB)	G <sub>a</sub> Antenna Gain(dB)	P <sub>Ag</sub> (dB)	Correction (dB)	ERP (dBm)	Limit (dBm)	Margin (dB)	Polarization
779.5	-19.22	3.21	9.61	33.89	2.15	18.92	34.77	-15.85	V
782.0	-19.00	3.23	9.52	34.74	2.15	19.88	34.77	-14.89	V
784.5	-19.47	3.25	9.43	34.85	2.15	19.41	34.77	-15.36	V

*LTE FDD Band 13 Channel Bandwidth 10MHz 16QAM*

Frequency (MHz)	P <sub>Mea</sub> (dBm)	P <sub>cl</sub> (dB)	G <sub>a</sub> Antenna Gain(dB)	P <sub>Ag</sub> (dB)	Correction (dB)	ERP (dBm)	Limit (dBm)	Margin (dB)	Polarization
782.0	-17.56	3.23	9.52	34.74	2.15	21.32	34.77	-13.45	V

*LTE FDD Band 25 Channel Bandwidth 1.4MHz QPSK*

Frequency (MHz)	P <sub>Mea</sub> (dBm)	P <sub>cl</sub> (dB)	G <sub>a</sub> Antenna Gain(dB)	P <sub>Ag</sub> (dB)	Burst Average EIRP (dBm)	Limit (dBm)	Margin (dB)	Polarization
1850.7	-17.28	4.03	8.38	35.51	22.58	33.01	-10.43	V
1882.5	-18.43	4.08	8.33	35.56	21.38	33.01	-11.63	V
1914.3	-17.68	4.14	8.26	35.63	22.07	33.01	-10.94	V

*LTE FDD Band 25 Channel Bandwidth 3MHz QPSK*

Frequency (MHz)	P <sub>Mea</sub> (dBm)	P <sub>cl</sub> (dB)	G <sub>a</sub> Antenna Gain(dB)	P <sub>Ag</sub> (dB)	Burst Average EIRP (dBm)	Limit (dBm)	Margin (dB)	Polarization
1851.5	-19.68	4.03	8.38	35.51	20.18	33.01	-12.83	V
1882.5	-17.33	4.08	8.33	35.56	22.48	33.01	-10.53	V
1913.5	-19.93	4.14	8.26	35.63	19.82	33.01	-13.19	V

*LTE FDD Band 25 Channel Bandwidth 5MHz QPSK*

Frequency (MHz)	P <sub>Mea</sub> (dBm)	P <sub>cl</sub> (dB)	G <sub>a</sub> Antenna Gain(dB)	P <sub>Ag</sub> (dB)	Burst Average EIRP (dBm)	Limit (dBm)	Margin (dB)	Polarization
1852.5	-17.55	4.03	8.38	35.51	22.31	33.01	-10.70	V
1882.5	-19.76	4.08	8.33	35.56	20.05	33.01	-12.96	V
1912.5	-17.53	4.14	8.26	35.63	22.22	33.01	-10.79	V

*LTE FDD Band 25 Channel Bandwidth 10MHz QPSK*

Frequency (MHz)	P <sub>Mea</sub> (dBm)	P <sub>cl</sub> (dB)	G <sub>a</sub> Antenna Gain(dB)	P <sub>Ag</sub> (dB)	Burst Average EIRP (dBm)	Limit (dBm)	Margin (dB)	Polarization
1855.0	-19.06	4.03	8.38	35.51	20.80	33.01	-12.21	V
1882.5	-18.65	4.08	8.33	35.56	21.16	33.01	-11.85	V
1910.0	-19.12	4.14	8.26	35.63	20.63	33.01	-12.38	V

*LTE FDD Band 25 Channel Bandwidth 15MHz QPSK*

Frequency (MHz)	P <sub>Mea</sub> (dBm)	P <sub>cl</sub> (dB)	G <sub>a</sub> Antenna Gain(dB)	P <sub>Ag</sub> (dB)	Burst Average EIRP (dBm)	Limit (dBm)	Margin (dB)	Polarization
1857.5	-19.29	4.03	8.38	35.51	20.57	33.01	-12.44	V
1882.5	-18.15	4.08	8.33	35.56	21.66	33.01	-11.35	V
1907.5	-17.72	4.14	8.26	35.63	22.03	33.01	-10.98	V

*LTE FDD Band 25 Channel Bandwidth 20MHz QPSK*

Frequency (MHz)	P <sub>Mea</sub> (dBm)	P <sub>cl</sub> (dB)	G <sub>a</sub> Antenna Gain(dB)	P <sub>Ag</sub> (dB)	Burst Average EIRP (dBm)	Limit (dBm)	Margin (dB)	Polarization
1860.0	-19.08	4.03	8.38	35.51	20.78	33.01	-12.23	V
1882.5	-19.47	4.08	8.33	35.56	20.34	33.01	-12.67	V
1905.0	-18.26	4.14	8.26	35.63	21.49	33.01	-11.52	V

*LTE FDD Band 25 Channel Bandwidth 1.4MHz 16QAM*

Frequency (MHz)	P <sub>Mea</sub> (dBm)	P <sub>cl</sub> (dB)	G <sub>a</sub> Antenna Gain(dB)	P <sub>Ag</sub> (dB)	Burst Average EIRP (dBm)	Limit (dBm)	Margin (dB)	Polarization
1850.7	-19.24	4.03	8.38	35.51	20.62	33.01	-12.39	V
1882.5	-19.89	4.08	8.33	35.56	19.92	33.01	-13.09	V
1914.3	-18.34	4.14	8.26	35.63	21.41	33.01	-11.60	V

*LTE FDD Band 25 Channel Bandwidth 3MHz 16QAM*

Frequency (MHz)	P <sub>Mea</sub> (dBm)	P <sub>cl</sub> (dB)	G <sub>a</sub> Antenna Gain(dB)	P <sub>Ag</sub> (dB)	Burst Average EIRP (dBm)	Limit (dBm)	Margin (dB)	Polarization
1851.5	-19.87	4.03	8.38	35.51	19.99	33.01	-13.02	V
1882.5	-17.42	4.08	8.33	35.56	22.39	33.01	-10.62	V
1913.5	-18.97	4.14	8.26	35.63	20.78	33.01	-12.23	V

*LTE FDD Band 25 Channel Bandwidth 5MHz 16QAM*

Frequency (MHz)	P <sub>Mea</sub> (dBm)	P <sub>cl</sub> (dB)	G <sub>a</sub> Antenna Gain(dB)	P <sub>Ag</sub> (dB)	Burst Average EIRP (dBm)	Limit (dBm)	Margin (dB)	Polarization
1852.5	-17.04	4.03	8.38	35.51	22.82	33.01	-10.19	V
1882.5	-17.06	4.08	8.33	35.56	22.75	33.01	-10.26	V
1912.5	-17.50	4.14	8.26	35.63	22.25	33.01	-10.76	V

*LTE FDD Band 25 Channel Bandwidth 10MHz 16QAM*

Frequency (MHz)	P <sub>Mea</sub> (dBm)	P <sub>cl</sub> (dB)	G <sub>a</sub> Antenna Gain(dB)	P <sub>Ag</sub> (dB)	Burst Average EIRP (dBm)	Limit (dBm)	Margin (dB)	Polarization
1855.0	-18.91	4.03	8.38	35.51	20.95	33.01	-12.06	V
1882.5	-18.86	4.08	8.33	35.56	20.95	33.01	-12.06	V
1910.0	-18.46	4.14	8.26	35.63	21.29	33.01	-11.72	V

*LTE FDD Band 25 Channel Bandwidth 15MHz 16QAM*

Frequency (MHz)	P <sub>Mea</sub> (dBm)	P <sub>cl</sub> (dB)	G <sub>a</sub> Antenna Gain(dB)	P <sub>Ag</sub> (dB)	Burst Average EIRP (dBm)	Limit (dBm)	Margin (dB)	Polarization
1857.5	-18.69	4.03	8.38	35.51	21.17	33.01	-11.84	V
1882.5	-19.33	4.08	8.33	35.56	20.48	33.01	-12.53	V
1907.5	-17.44	4.14	8.26	35.63	22.31	33.01	-10.70	V

*LTE FDD Band 25 Channel Bandwidth 20MHz 16QAM*

Frequency (MHz)	P <sub>Mea</sub> (dBm)	P <sub>cl</sub> (dB)	G <sub>a</sub> Antenna Gain(dB)	P <sub>Ag</sub> (dB)	Burst Average EIRP (dBm)	Limit (dBm)	Margin (dB)	Polarization
1860.0	-19.17	4.03	8.38	35.51	20.69	33.01	-12.32	V
1882.5	-18.34	4.08	8.33	35.56	21.47	33.01	-11.54	V
1905.0	-19.32	4.14	8.26	35.63	20.43	33.01	-12.58	V

**LTE FDD Band 26: 814MHz~824MHz***LTE FDD Band 26 Channel Bandwidth 1.4MHz QPSK*

Frequency (MHz)	P <sub>Mea</sub> (dBm)	P <sub>cl</sub> (dB)	G <sub>a</sub> Antenna Gain (dB)	P <sub>Ag</sub> (dB)	Correction (dB)	Burst Average ERP (dBm)	Limit (dBm)	Margin (dB)	Polarization
814.70	-18.20	3.58	9.62	33.79	2.15	19.48	50.00	-30.52	V
819.00	-18.33	3.61	9.22	34.64	2.15	19.77	50.00	-30.23	V
823.30	-17.63	3.64	9.04	34.75	2.15	20.37	50.00	-29.63	V

*LTE FDD Band 26 Channel Bandwidth 3MHz QPSK*

Frequency (MHz)	P <sub>Mea</sub> (dBm)	P <sub>cl</sub> (dB)	G <sub>a</sub> Antenna Gain (dB)	P <sub>Ag</sub> (dB)	Correction (dB)	Burst Avergae ERP (dBm)	Limit (dBm)	Margin (dB)	Polarization
815.50	-17.68	3.58	9.62	33.79	2.15	20.00	50.00	-30.00	V
819.00	-17.38	3.61	9.22	34.64	2.15	20.72	50.00	-29.28	V
822.50	-17.33	3.64	9.04	34.75	2.15	20.67	50.00	-29.33	V

*LTE FDD Band 26 Channel Bandwidth 5MHz QPSK*

Frequency (MHz)	P <sub>Mea</sub> (dBm)	P <sub>cl</sub> (dB)	G <sub>a</sub> Antenna Gain (dB)	P <sub>Ag</sub> (dB)	Correction (dB)	Burst Avergae ERP (dBm)	Limit (dBm)	Margin (dB)	Polarization
816.50	-16.89	3.58	9.62	33.79	2.15	20.79	50.00	-29.21	V
819.00	-16.52	3.61	9.22	34.64	2.15	21.58	50.00	-28.42	V
821.50	-17.32	3.64	9.04	34.75	2.15	20.68	50.00	-29.32	V

*LTE FDD Band 26 Channel Bandwidth 10MHz QPSK*

Frequency (MHz)	P <sub>Mea</sub> (dBm)	P <sub>cl</sub> (dB)	G <sub>a</sub> Antenna Gain (dB)	P <sub>Ag</sub> (dB)	Correction (dB)	Burst Avergae ERP (dBm)	Limit (dBm)	Margin (dB)	Polarization
819.00	-16.94	3.64	9.04	34.75	2.15	21.06	50.00	-28.94	V

*LTE FDD Band 26 Channel Bandwidth 1.4MHz 16QAM*

Frequency (MHz)	P <sub>Mea</sub> (dBm)	P <sub>cl</sub> (dB)	G <sub>a</sub> Antenna Gain (dB)	P <sub>Ag</sub> (dB)	Correction (dB)	Burst Avergae ERP (dBm)	Limit (dBm)	Margin (dB)	Polarization
814.70	-18.67	3.58	9.62	33.79	2.15	19.01	50.00	-30.99	V
819.00	-19.23	3.61	9.22	34.64	2.15	18.87	50.00	-31.13	V
823.30	-18.66	3.64	9.04	34.75	2.15	19.34	50.00	-30.66	V

*LTE FDD Band 26 Channel Bandwidth 3MHz 16QAM*

Frequency (MHz)	P <sub>Mea</sub> (dBm)	P <sub>cl</sub> (dB)	G <sub>a</sub> Antenna Gain (dB)	P <sub>Ag</sub> (dB)	Correction (dB)	Burst Avergae ERP (dBm)	Limit (dBm)	Margin (dB)	Polarization
815.50	-18.64	3.58	9.62	33.79	2.15	19.04	50.00	-30.96	V
819.00	-18.94	3.61	9.22	34.64	2.15	19.16	50.00	-30.84	V
822.50	-18.27	3.64	9.04	34.75	2.15	19.73	50.00	-30.27	V

*LTE FDD Band 26 Channel Bandwidth 5MHz 16QAM*

Frequency (MHz)	P <sub>Mea</sub> (dBm)	P <sub>cl</sub> (dB)	G <sub>a</sub> Antenna Gain (dB)	P <sub>Ag</sub> (dB)	Correction (dB)	Burst Avergae ERP (dBm)	Limit (dBm)	Margin (dB)	Polarization
816.50	-17.52	3.58	9.62	33.79	2.15	20.16	50.00	-29.84	V
819.00	-17.35	3.61	9.22	34.64	2.15	20.75	50.00	-29.25	V
821.50	-17.83	3.64	9.04	34.75	2.15	20.17	50.00	-29.83	V

*LTE FDD Band 26 Channel Bandwidth 10MHz 16QAM*

Frequency (MHz)	P <sub>Mea</sub> (dBm)	P <sub>cl</sub> (dB)	G <sub>a</sub> Antenna Gain (dB)	P <sub>Ag</sub> (dB)	Correction (dB)	Burst Avergae ERP (dBm)	Limit (dBm)	Margin (dB)	Polarization
819.00	-17.33	3.64	9.04	34.75	2.15	20.67	50.00	-29.33	V

**LTE FDD Band 26: 824MHz~849MHz***LTE FDD Band 26 Channel Bandwidth 1.4MHz QPSK*

Frequency (MHz)	P <sub>Mea</sub> (dBm)	P <sub>cl</sub> (dB)	G <sub>a</sub> Antenna Gain (dB)	P <sub>Ag</sub> (dB)	Correction (dB)	Burst Avergae ERP (dBm)	Limit (dBm)	Margin (dB)	Polarization
824.70	-18.42	3.58	9.62	33.79	2.15	19.26	38.45	-19.19	V
836.50	-18.46	3.61	9.22	34.64	2.15	19.64	38.45	-18.81	V
848.30	-17.56	3.64	9.04	34.75	2.15	20.44	38.45	-18.01	V

*LTE FDD Band 26 Channel Bandwidth 3MHz QPSK*

Frequency (MHz)	P <sub>Mea</sub> (dBm)	P <sub>cl</sub> (dB)	G <sub>a</sub> Antenna Gain (dB)	P <sub>Ag</sub> (dB)	Correction (dB)	Burst Avergae ERP (dBm)	Limit (dBm)	Margin (dB)	Polarization
825.50	-17.68	3.58	9.62	33.79	2.15	20.00	38.45	-18.45	V
836.50	-17.40	3.61	9.22	34.64	2.15	20.70	38.45	-17.75	V
847.50	-17.49	3.64	9.04	34.75	2.15	20.51	38.45	-17.94	V

*LTE FDD Band 26 Channel Bandwidth 5MHz QPSK*

Frequency (MHz)	P <sub>Mea</sub> (dBm)	P <sub>cl</sub> (dB)	G <sub>a</sub> Antenna Gain (dB)	P <sub>Ag</sub> (dB)	Correction (dB)	Burst Avergae ERP (dBm)	Limit (dBm)	Margin (dB)	Polarization
826.50	-16.74	3.58	9.62	33.79	2.15	20.94	38.45	-17.51	V
836.50	-17.19	3.61	9.22	34.64	2.15	20.91	38.45	-17.54	V
846.50	-16.52	3.64	9.04	34.75	2.15	21.48	38.45	-16.97	V

*LTE FDD Band 26 Channel Bandwidth 10MHz QPSK*

Frequency (MHz)	P <sub>Mea</sub> (dBm)	P <sub>cl</sub> (dB)	G <sub>a</sub> Antenna Gain (dB)	P <sub>Ag</sub> (dB)	Correction (dB)	Burst Avergae ERP (dBm)	Limit (dBm)	Margin (dB)	Polarization
829.00	-16.48	3.58	9.62	33.79	2.15	21.20	38.45	-17.25	V
836.50	-16.54	3.61	9.22	34.64	2.15	21.56	38.45	-16.89	V
844.00	-16.92	3.64	9.04	34.75	2.15	21.08	38.45	-17.37	V

*LTE FDD Band 26 Channel Bandwidth 15MHz QPSK*

Frequency (MHz)	P <sub>Mea</sub> (dBm)	P <sub>cl</sub> (dB)	G <sub>a</sub> Antenna Gain (dB)	P <sub>Ag</sub> (dB)	Correction (dB)	Burst Avergae ERP (dBm)	Limit (dBm)	Margin (dB)	Polarization
831.50	-16.06	3.58	9.62	33.79	2.15	21.62	38.45	-16.83	V
836.50	-15.79	3.61	9.22	34.64	2.15	22.31	38.45	-16.14	V
841.50	-16.40	3.64	9.04	34.75	2.15	21.60	38.45	-16.85	V

*LTE FDD Band 26 Channel Bandwidth 1.4MHz 16QAM*

Frequency (MHz)	P <sub>Mea</sub> (dBm)	P <sub>cl</sub> (dB)	G <sub>a</sub> Antenna Gain (dB)	P <sub>Ag</sub> (dB)	Correction (dB)	Burst Avergae ERP (dBm)	Limit (dBm)	Margin (dB)	Polarization
824.70	-18.92	3.58	9.62	33.79	2.15	18.76	38.45	-19.69	V
836.50	-18.84	3.61	9.22	34.64	2.15	19.26	38.45	-19.19	V
848.30	-19.39	3.64	9.04	34.75	2.15	18.61	38.45	-19.84	V

*LTE FDD Band 26 Channel Bandwidth 3MHz 16QAM*

Frequency (MHz)	P <sub>Mea</sub> (dBm)	P <sub>cl</sub> (dB)	G <sub>a</sub> Antenna Gain (dB)	P <sub>Ag</sub> (dB)	Correction (dB)	Burst Avergae ERP (dBm)	Limit (dBm)	Margin (dB)	Polarization
825.50	-18.35	3.58	9.62	33.79	2.15	19.33	38.45	-19.12	V
836.50	-18.04	3.61	9.22	34.64	2.15	20.06	38.45	-18.39	V
847.50	-17.75	3.64	9.04	34.75	2.15	20.25	38.45	-18.20	V

*LTE FDD Band 26 Channel Bandwidth 5MHz 16QAM*

Frequency (MHz)	P <sub>Mea</sub> (dBm)	P <sub>cl</sub> (dB)	G <sub>a</sub> Antenna Gain (dB)	P <sub>Ag</sub> (dB)	Correction (dB)	Burst Avergae ERP (dBm)	Limit (dBm)	Margin (dB)	Polarization
826.50	-17.79	3.58	9.62	33.79	2.15	19.89	38.45	-18.56	V
836.50	-17.58	3.61	9.22	34.64	2.15	20.52	38.45	-17.93	V
846.50	-17.93	3.64	9.04	34.75	2.15	20.07	38.45	-18.38	V

*LTE FDD Band 26 Channel Bandwidth 10MHz 16QAM*

Frequency (MHz)	P <sub>Mea</sub> (dBm)	P <sub>cl</sub> (dB)	G <sub>a</sub> Antenna Gain (dB)	P <sub>Ag</sub> (dB)	Correction (dB)	Burst Avergae ERP (dBm)	Limit (dBm)	Margin (dB)	Polarization
829.00	-17.40	3.58	9.62	33.79	2.15	20.28	38.45	-18.17	V
836.50	-17.18	3.61	9.22	34.64	2.15	20.92	38.45	-17.53	V
844.00	-17.06	3.64	9.04	34.75	2.15	20.94	38.45	-17.51	V

*LTE FDD Band 26 Channel Bandwidth 15MHz 16QAM*

Frequency (MHz)	P <sub>Mea</sub> (dBm)	P <sub>cl</sub> (dB)	G <sub>a</sub> Antenna Gain (dB)	P <sub>Ag</sub> (dB)	Correction (dB)	Burst Avergae ERP (dBm)	Limit (dBm)	Margin (dB)	Polarization
831.50	-16.74	3.58	9.62	33.79	2.15	20.94	38.45	-17.51	V
836.50	-16.03	3.61	9.22	34.64	2.15	22.07	38.45	-16.38	V
841.50	-16.60	3.64	9.04	34.75	2.15	21.40	38.45	-17.05	V



## 4.2 Peak-to-Average Ratio (PAR)

### LIMIT

The Peak-to-Average Ratio (PAR) of the transmission may not exceed 13 dB.

### TEST CONFIGURATION

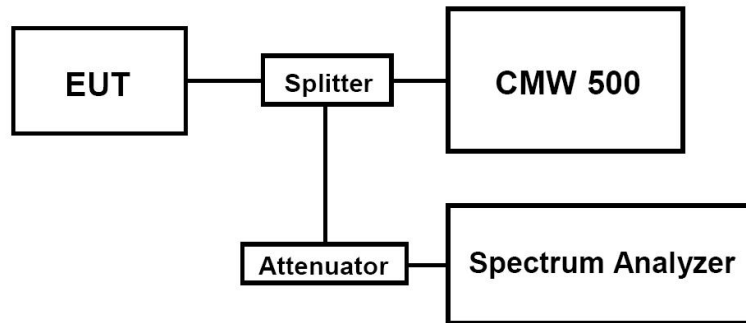

### TEST PROCEDURE

1. Refer to instrument's analyzer instruction manual for details on how to use the power statistics/CCDF function;
2. Set resolution/measurement bandwidth  $\geq$  signal's occupied bandwidth;
3. Set the number of counts to a value that stabilizes the measured CCDF curve;
4. Set the measurement interval as follows:
  - 1). for continuous transmissions, set to 1 ms,
  - 2). for burst transmissions, employ an external trigger that is synchronized with the EUT burst timing sequence, or use the internal burst trigger with a trigger level that allows the burst to stabilize and set the measurement interval to a time that is less than or equal to the burst duration.
5. Record the maximum PAPR level associated with a probability of 0.1%.

### TEST RESULTS

#### Remark:

1. We were tested all RB Configuration refer 3GPP TS136 521 for each Channel Bandwidth of LTE FDD Band 2, LTE FDD Band 4, LTE FDD Band 5, LTE FDD Band 12, LTE FDD Band 13, LTE FDD Band 25, LTE FDD Band 26; recorded worst case for each Channel Bandwidth of LTE FDD Band 2, LTE FDD Band 4, LTE FDD Band 5, LTE FDD Band 12, LTE FDD Band 13, LTE FDD Band 25, LTE FDD Band 26.
2. For E-UTRA Band 2, please refer to Appendix A: Section A.2
3. For E-UTRA Band 4, please refer to Appendix B: Section B.2
4. For E-UTRA Band 5, please refer to Appendix C: Section C.2
5. For E-UTRA Band 12, please refer to Appendix D: Section D.2
6. For E-UTRA Band 13, please refer to Appendix E: Section E.2
7. For E-UTRA Band 25, please refer to Appendix F: Section F.2
8. For E-UTRA Band 26, please refer to Appendix G: Section G.2 & Appendix H: Section H.2





### 4.3 Occupied Bandwidth and Emission Bandwidth

#### LIMIT

N/A

#### TEST CONFIGURATION

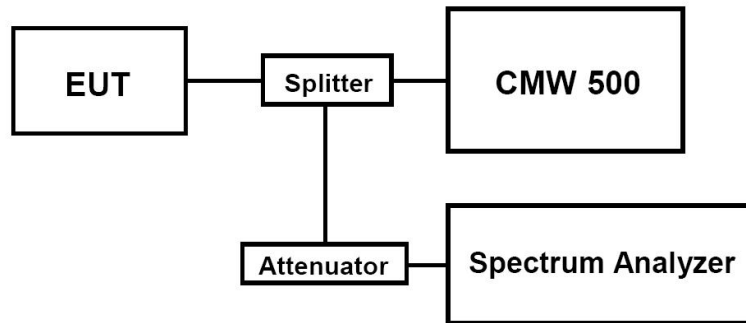

#### TEST PROCEDURE

The transmitter output was connected to a calibrated coaxial cable and coupler, the other end of which was connected to a spectrum analyzer. The occupied bandwidth was measured with the spectrum analyzer at low, middle and high channel in each band. The -26dBc Emission bandwidth was also measured and recorded.

Set RBW was set to about 1% of emission BW, VBW  $\geq 3$  times RBW.

-26dBc display line was placed on the screen (or 99% bandwidth), the occupied bandwidth is the delta frequency between the two points where the display line intersects the signal trace.

#### TEST RESULTS

##### *Remark:*

1. We were tested all RB Configuration refer 3GPP TS136 521 for each Channel Bandwidth of LTE FDD Band 2, LTE FDD Band 4, LTE FDD Band 5, LTE FDD Band 12, LTE FDD Band 13, LTE FDD Band 25, LTE FDD Band 26; recorded worst case for each Channel Bandwidth of LTE FDD Band 2, LTE FDD Band 4, LTE FDD Band 5, LTE FDD Band 12, LTE FDD Band 13, LTE FDD Band 25, LTE FDD Band 26.
2. For E-UTRA Band 2, please refer to Appendix A: Section A.3
3. For E-UTRA Band 4, please refer to Appendix B: Section B.3
4. For E-UTRA Band 5, please refer to Appendix C: Section C.3
5. For E-UTRA Band 12, please refer to Appendix D: Section D.3
6. For E-UTRA Band 13, please refer to Appendix E: Section E.3
7. For E-UTRA Band 25, please refer to Appendix F: Section F.3
8. For E-UTRA Band 26, please refer to Appendix G: Section G.3 & Appendix H: Section H.3



## 4.4 Band Edge compliance

### LIMIT

For LTE FDD Band 2: Per FCC §24.238 the power of any emission outside of the authorized operating frequency ranges must be attenuated below the transmitting power (P) by a factor of at least  $43 + 10\log(P)$  dB.

For LTE FDD Band 4: Per §27.53(h): For operations in the 1710–1755 MHz and 2110–2155 MHz bands, the power of any emission outside a licensee's frequency block shall be attenuated below the transmitter power (P) by at least  $43 + 10 \log_{10}(P)$  dB.

For LTE FDD Band 5: Per FCC §22.917 the power of any emission outside of the authorized operating frequency ranges must be attenuated below the transmitting power (P) by a factor of at least  $43 + 10\log(P)$  dB.

For LTE FDD Band 12: Per §27.53 (g): For operations in the 698–746 MHz band, the power of any emission outside a licensee's frequency band(s) of operation shall be attenuated below the transmitter power (P) within the licensed band(s) of operation, measured in watts, by at least  $43 + 10 \log (P)$  dB.

*For LTE FDD Band 13:* Per §27.53 (c): For operations in the 776-788 MHz band, the power of any emission outside the licensee's frequency band(s) of operation shall be attenuated below the transmitter power (P) within the licensed band(s) of operation, measured in watts, in accordance with the following: On any frequency outside the 776-788 MHz band, the power of any emission shall be attenuated outside the band below the transmitter power (P) by at least  $43 + 10 \log (P)$  dB; On all frequencies between 763-775 MHz and 793-805 MHz, by a factor not less than  $65 + 10 \log (P)$  dB in a 6.25 kHz band segment, for mobile and portable stations;

*For LTE FDD Band 25:* Per FCC §24.238 the power of any emission outside of the authorized operating frequency ranges must be attenuated below the transmitting power (P) by a factor of at least  $43 + 10\log(P)$  dB.

*For LTE FDD Band 26:* Per FCC §90.669 the power of any emission shall be attenuated below the transmitter power (P) by at least  $43 + 10 \log_{10}(P)$  decibels or 80 decibels, whichever is the lesser attenuation.

Per FCC §22.917 the power of any emission outside of the authorized operating frequency ranges must be attenuated below the transmitting power (P) by a factor of at least  $43 + 10\log(P)$  dB.



## TEST CONFIGURATION

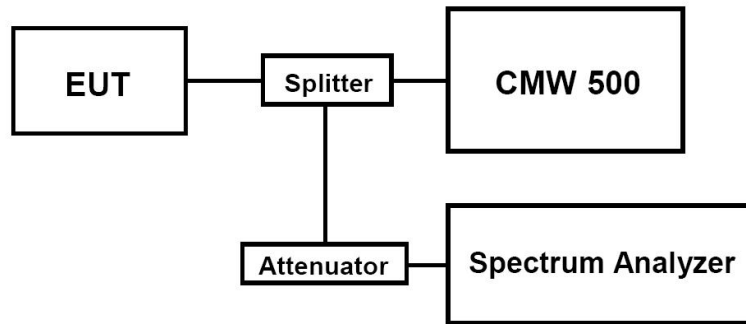

## TEST PROCEDURE

1. The transmitter output port was connected to base station.
2. The RF output of EUT was connected to the power meter by RF cable and attenuator, the path loss was compensated to the results for each measurement.
3. Set EUT at maximum power through base station.
4. Select lowest and highest channels for each band and different modulation.
5. Measure Band edge using RMS (Average) detector by spectrum

## TEST RESULTS

### *Remark:*

1. We were tested all RB Configuration refer 3GPP TS136 521 for each Channel Bandwidth of LTE FDD Band 2, LTE FDD Band 4, LTE FDD Band 5, LTE FDD Band 12, LTE FDD Band 13, LTE FDD Band 25, LTE FDD Band 26; recorded worst case for each Channel Bandwidth of LTE FDD Band 2, LTE FDD Band 4, LTE FDD Band 5, LTE FDD Band 12, LTE FDD Band 13, LTE FDD Band 25, LTE FDD Band 26.
2. For E-UTRA Band 2, please refer to Appendix A: Section A.4
3. For E-UTRA Band 4, please refer to Appendix B: Section B.4
4. For E-UTRA Band 5, please refer to Appendix C: Section C.4
5. For E-UTRA Band 12, please refer to Appendix D: Section D.4
6. For E-UTRA Band 13, please refer to Appendix E: Section E.4
7. For E-UTRA Band 25, please refer to Appendix F: Section F.4
8. For E-UTRA Band 26, please refer to Appendix G: Section G.4 & Appendix H: Section H.4



## 1.1 Spurious Emission on Antenna Port

### LIMIT

For LTE FDD Band 2: Per FCC §24.238 the power of any emission outside of the authorized operating frequency ranges must be attenuated below the transmitting power (P) by a factor of at least  $43 + 10\log(P)$  dB.

For LTE FDD Band 4: Per §27.53(h): For operations in the 1710–1755 MHz and 2110–2155 MHz bands, the power of any emission outside a licensee's frequency block shall be attenuated below the transmitter power (P) by at least  $43 + 10 \log_{10}(P)$  dB.

For LTE FDD Band 5: Per FCC §22.917 the power of any emission outside of the authorized operating frequency ranges must be attenuated below the transmitting power (P) by a factor of at least  $43 + 10\log(P)$  dB.

For LTE FDD Band 12: Per §27.53 (g): For operations in the 698–746 MHz band, the power of any emission outside a licensee's frequency band(s) of operation shall be attenuated below the transmitter power (P) within the licensed band(s) of operation, measured in watts, by at least  $43 + 10 \log (P)$  dB.

For LTE FDD Band 13: Per §27.53 (c): For operations in the 776-788 MHz band, the power of any emission outside the licensee's frequency band(s) of operation shall be attenuated below the transmitter power (P) within the licensed band(s) of operation, measured in watts, in accordance with the following: On any frequency outside the 776-788 MHz band, the power of any emission shall be attenuated outside the band below the transmitter power (P) by at least  $43 + 10 \log (P)$  dB; On all frequencies between 763-775 MHz and 793-805 MHz, by a factor not less than  $65 + 10 \log (P)$  dB in a 6.25 kHz band segment, for mobile and portable stations;

For LTE FDD Band 25: Per FCC §24.238 the power of any emission outside of the authorized operating frequency ranges must be attenuated below the transmitting power (P) by a factor of at least  $43 + 10\log(P)$  dB.

For LTE FDD Band 26: Per FCC §90.669 the power of any emission shall be attenuated below the transmitter power (P) by at least  $43 + 10 \log_{10}(P)$  decibels or 80 decibels, whichever is the lesser attenuation.

Per FCC §22.917 the power of any emission outside of the authorized operating frequency ranges must be attenuated below the transmitting power (P) by a factor of at least  $43 + 10\log(P)$  dB.

### TEST CONFIGURATION

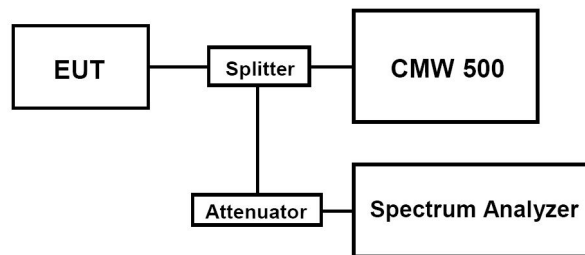

**TEST PROCEDURE**

The EUT was setup according to TIA-603-E

- Place the EUT on a bench and set it in transmitting mode.
- Connect a low loss RF cable from the antenna port to a spectrum analyzer and CMW 500 by a Directional Couple.
- EUT Communicate with CMW 500, then select a channel for testing.
- Add a correction factor to the display of spectrum, and then test.
- The resolution bandwidth of the spectrum analyzer was setsufficient scans were taken to show the out of band Emission if any up to10<sup>th</sup> harmonic.
- Please refer to following tables for test antenna conducted emissions.

Working Frequency	Sub range (GHz)	RBW	VBW	Sweep time (s)
LTE FDD Band 2	0.000009~0.000015	1KHz	3KHz	Auto
	0.000015~0.03	10KHz	30KHz	Auto
	0.03~26	1 MHz	3 MHz	Auto
LTE FDD Band 4	0.000009~0.000015	1KHz	3KHz	Auto
	0.000015~0.03	10KHz	30KHz	Auto
	0.03~26	1 MHz	3 MHz	Auto
LTE FDD Band 5	0.000009~0.000015	1KHz	3KHz	Auto
	0.000015~0.03	10KHz	30KHz	Auto
	0.03~26	1 MHz	3 MHz	Auto
LTE FDD Band 12	0.000009~0.000015	1KHz	3KHz	Auto
	0.000015~0.03	10KHz	30KHz	Auto
	0.03~26	1 MHz	3 MHz	Auto
LTE FDD Band 13	0.000009~0.000015	1KHz	3KHz	Auto
	0.000015~0.03	10KHz	30KHz	Auto
	0.03~26	1 MHz	3 MHz	Auto
LTE FDD Band 25	0.000009~0.000015	1KHz	3KHz	Auto
	0.000015~0.03	10KHz	30KHz	Auto
	0.03~26	1 MHz	3 MHz	Auto
LTE FDD Band 26	0.000009~0.000015	1KHz	3KHz	Auto
	0.000015~0.03	10KHz	30KHz	Auto
	0.03~26	1 MHz	3 MHz	Auto

**TEST RESULTS**

Remark:

- We were tested all RB Configuration refer 3GPP TS136 521 for each Channel Bandwidth of LTE FDD Band 2, LTE FDD Band 4, LTE FDD Band 5, LTE FDD Band 12, LTE FDD Band 13, LTE FDD Band 25, LTE FDD Band 26; recorded worst case for each Channel Bandwidth of LTE FDD Band 2, LTE FDD Band 4, LTE FDD Band 5, LTE FDD Band 12, LTE FDD Band 13, LTE FDD Band 25, LTE FDD Band 26.
- For E-UTRA Band 2, please refer to Appendix A: Section A.5
- For E-UTRA Band 4, please refer to Appendix B: Section B.5
- For E-UTRA Band 5, please refer to Appendix C: Section C.5
- For E-UTRA Band 12, please refer to Appendix D: Section D.5
- For E-UTRA Band 13, please refer to Appendix E: Section E.5
- For E-UTRA Band 25, please refer to Appendix F: Section F.5
- For E-UTRA Band 26, please refer to Appendix G: Section G.5 & Appendix H: Section H.5

## 4.5 Radiated Spurious Emission

### LIMIT

For LTE FDD Band 2: Per FCC §24.238 the power of any emission outside of the authorized operating frequency ranges must be attenuated below the transmitting power (P) by a factor of at least  $43 + 10\log(P)$  dB.

For LTE FDD Band 4: Per §27.53(h): For operations in the 1710–1755 MHz and 2110–2155 MHz bands, the power of any emission outside a licensee's frequency block shall be attenuated below the transmitter power (P) by at least  $43 + 10 \log_{10}(P)$  dB.

For LTE FDD Band 5: Per FCC §22.917 the power of any emission outside of the authorized operating frequency ranges must be attenuated below the transmitting power (P) by a factor of at least  $43 + 10\log(P)$  dB.

For LTE FDD Band 12: Per §27.53 (g): For operations in the 698–746 MHz band, the power of any emission outside a licensee's frequency band(s) of operation shall be attenuated below the transmitter power (P) within the licensed band(s) of operation, measured in watts, by at least  $43 + 10 \log (P)$  dB.

For LTE FDD Band 13: Per §27.53 (c): For operations in the 776-788 MHz band, the power of any emission outside the licensee's frequency band(s) of operation shall be attenuated below the transmitter power (P) within the licensed band(s) of operation, measured in watts, in accordance with the following: On any frequency outside the 776-788 MHz band, the power of any emission shall be attenuated outside the band below the transmitter power (P) by at least  $43 + 10 \log (P)$  dB; On all frequencies between 763-775 MHz and 793-805 MHz, by a factor not less than  $65 + 10 \log (P)$  dB in a 6.25 kHz band segment, for mobile and portable stations;

For LTE FDD Band 25: Per FCC §24.238 the power of any emission outside of the authorized operating frequency ranges must be attenuated below the transmitting power (P) by a factor of at least  $43 + 10\log(P)$  dB.

For LTE FDD Band 26: Per FCC §90.669 the power of any emission shall be attenuated below the transmitter power (P) by at least  $43 + 10 \log_{10}(P)$  decibels or 80 decibels, whichever is the lesser attenuation. Per FCC §22.917 the power of any emission outside of the authorized operating frequency ranges must be attenuated below the transmitting power (P) by a factor of at least  $43 + 10\log(P)$  dB.

### TEST CONFIGURATION

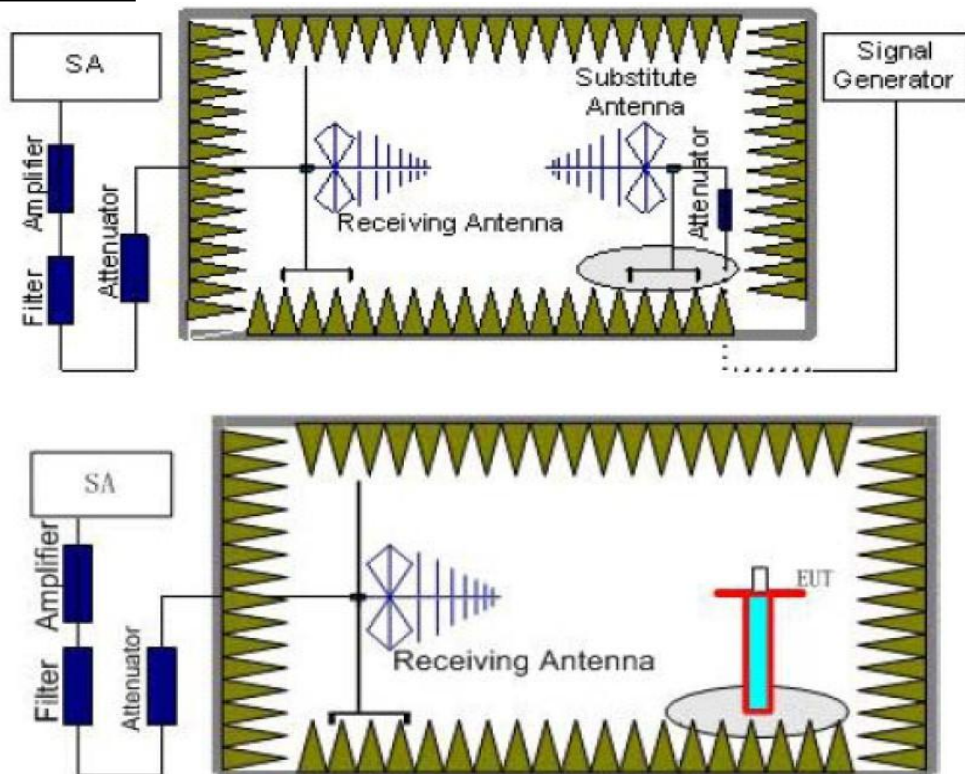

**TEST PROCEDURE**

- EUT was placed on a 1.50 meter high non-conductive stand at a 3 meter test distance from the receive antenna. A receiving antenna was placed on the antenna mast 3 meters from the EUT for emission measurements. The height of receiving antenna is 1.50m. Detected emissions were maximized at each frequency by rotating the EUT through 360° and adjusting the receiving antenna polarization. The radiated emission measurements of all transmit frequencies in three channels (High, Middle, Low) were measured with peak detector.
- A log-periodic antenna or double-ridged waveguide horn antenna shall be substituted in place of the EUT. The log-periodic antenna will be driven by a signal generator and the level will be adjusted till the same power value on the spectrum analyzer or receiver. The level of the spurious emissions can be calculated through the level of the signal generator, cable loss, the gain of the substitution antenna and the reading of the spectrum analyzer or receiver.
- The EUT is then put into continuously transmitting mode at its maximum power level during the test. Set Test Receiver or Spectrum RBW=1MHz, VBW=3MHz, And the maximum value of the receiver should be recorded as ( $P_r$ ).
- The EUT shall be replaced by a substitution antenna. In the chamber, an substitution antenna for the frequency band of interest is placed at the reference point of the chamber. An RF Signal source for the frequency band of interest is connected to the substitution antenna with a cable that has been constructed to not interfere with the radiation pattern of the antenna. A power ( $P_{Mea}$ ) is applied to the input of the substitution antenna, and adjust the level of the signal generator output until the value of the receiver reach the previously recorded ( $P_r$ ). The power of signal source ( $P_{Mea}$ ) is recorded. The test should be performed by rotating the test item and adjusting the receiving antenna polarization.
- A amplifier should be connected to the Signal Source output port. And the cable should be connect between the Amplifier and the Substitution Antenna. The cable loss ( $P_{cl}$ ), the Substitution Antenna Gain ( $G_a$ ) and the Amplifier Gain ( $P_{Ag}$ ) should be recorded after test.  
The measurement results are obtained as described below:  
 $Power(EIRP) = P_{Mea} + P_{Ag} - P_{cl} + G_a$
- This value is EIRP since the measurement is calibrated using an antenna of known gain (2.15 dBi) and known input power.
- ERP can be calculated from EIRP by subtracting the gain of the dipole,  $ERP = EIRP - 2.15dBi$ .
- In order to make sure test results more clearly, we set frequency range and sweep time for difference frequency range as follows table:

Working Frequency	Subrange (GHz)	RBW	VBW	Sweep time (s)
LTE FDD Band 2	0.00009~0.15	1KHz	3KHz	30
	0.00015~0.03	10KHz	30KHz	10
	0.03~1	100KHz	300KHz	10
	1~2	1 MHz	3 MHz	2
	2~5	1 MHz	3 MHz	3
	5~8	1 MHz	3 MHz	3
	8~11	1 MHz	3 MHz	3
	11~14	1 MHz	3 MHz	3
LTE FDD Band 4	14~18	1 MHz	3 MHz	3
	18~20	1 MHz	3 MHz	2
	0.00009~0.15	1KHz	3KHz	30
	0.00015~0.03	10KHz	30KHz	10
	0.03~1	100KHz	300KHz	10
	1~2	1 MHz	3 MHz	2
	2~5	1 MHz	3 MHz	3
	5~8	1 MHz	3 MHz	3
LTE FDD Band 5	8~11	1 MHz	3 MHz	3
	11~14	1 MHz	3 MHz	3
	14~18	1 MHz	3 MHz	3
	0.00009~0.15	1KHz	3KHz	30
	0.00015~0.03	10KHz	30KHz	10
	0.03~1	100KHz	300KHz	10
LTE FDD Band 12	1~2	1 MHz	3 MHz	2
	2~5	1 MHz	3 MHz	3
	5~8	1 MHz	3 MHz	3
	8~9	1 MHz	3 MHz	3
	0.00009~0.15	1KHz	3KHz	30



	0.00015~0.03	10KHz	30KHz	10
	0.03~1	100KHz	300KHz	10
	1~2	1 MHz	3 MHz	2
	2~5	1 MHz	3 MHz	3
	5~8	1 MHz	3 MHz	3
	0.00009~0.15	1KHz	3KHz	30
	0.00015~0.03	10KHz	30KHz	10
	0.03~1	100KHz	300KHz	10
	1~2	1 MHz	3 MHz	2
	2~5	1 MHz	3 MHz	3
LTE FDD Band 13	0.00009~0.15	1KHz	3KHz	30
	0.00015~0.03	10KHz	30KHz	10
	0.03~1	100KHz	300KHz	10
	1~2	1 MHz	3 MHz	2
	2~5	1 MHz	3 MHz	3
	5~8	1 MHz	3 MHz	3
LTE FDD Band 25	0.00009~0.15	1KHz	3KHz	30
	0.00015~0.03	10KHz	30KHz	10
	0.03~1	100KHz	300KHz	10
	1~2	1 MHz	3 MHz	2
	2~5	1 MHz	3 MHz	3
	5~8	1 MHz	3 MHz	3
	8~11	1 MHz	3 MHz	3
	11~14	1 MHz	3 MHz	3
	14~18	1 MHz	3 MHz	3
	18~20	1 MHz	3 MHz	2
LTE FDD Band 26	0.00009~0.15	1KHz	3KHz	30
	0.00015~0.03	10KHz	30KHz	10
	0.03~1	100KHz	300KHz	10
	1~2	1 MHz	3 MHz	2
	2~5	1 MHz	3 MHz	3
	5~8	1 MHz	3 MHz	3
	8~11	1 MHz	3 MHz	3

Frequency	Channel	Frequency Range	Verdict
LTE FDD Band 2	Low	9KHz -20GHz	PASS
	Middle	9KHz -20GHz	PASS
	High	9KHz -20GHz	PASS
LTE FDD Band 4	Low	9KHz -18GHz	PASS
	Middle	9KHz -18GHz	PASS
	High	9KHz -18GHz	PASS
LTE FDD Band 5	Low	9KHz -9GHz	PASS
	Middle	9KHz -9GHz	PASS
	High	9KHz -26GHz	PASS
LTE FDD Band 12	Low	9KHz -8GHz	PASS
	Middle	9KHz -8GHz	PASS
	High	9KHz -8GHz	PASS
LTE FDD Band 13	Low	9KHz -8GHz	PASS
	Middle	9KHz -8GHz	PASS
	High	9KHz -8GHz	PASS
LTE FDD Band 25	Low	9KHz -20GHz	PASS
	Middle	9KHz -20GHz	PASS
	High	9KHz -20GHz	PASS
LTE FDD Band 26	Low	9KHz -8GHz	PASS
	Middle	9KHz -8GHz	PASS
	High	9KHz -8GHz	PASS



### TEST RESULTS

Remark:

1. We were tested all RB Configuration refer 3GPP TS136 521 for each Channel Bandwidth of LTE FDD Band 2, LTE FDD Band 4, LTE FDD Band 5, LTE FDD Band 12, LTE FDD Band 13, LTE FDD Band 25, LTE FDD Band 26; recorded worst case for each Channel Bandwidth of LTE FDD Band 2, LTE FDD Band 4, LTE FDD Band 5, LTE FDD Band 12, LTE FDD Band 13, LTE FDD Band 25, LTE FDD Band 26.
3. We were not recorded other points as values lower than limits.
4.  $Power(EIRP) = P_{Mea} + P_{Ag} - P_{cl} + G_a$
5.  $Margin = EIRP - Limit$

*LTE FDD Band 2 Channel Bandwidth 20MHz QPSK Low Channel*

Frequency (MHz)	P <sub>Mea</sub> (dBm)	P <sub>cl</sub> (dB)	Diatance	G <sub>a</sub> Antenna Gain(dB)	Peak EIRP (dBm)	Limit (dBm)	Margin (dB)	Polarization
3715.0	-38.18	5.26	3.00	9.88	-33.56	-13.00	-20.56	H
5572.5	-46.84	6.11	3.00	11.36	-41.59	-13.00	-28.59	H
3715.0	-28.64	5.26	3.00	9.88	-24.02	-13.00	-11.02	V
5572.5	-35.44	6.11	3.00	11.36	-30.19	-13.00	-17.19	V

*LTE FDD Band 2 Channel Bandwidth 20MHz QPSK Middle Channel*

Frequency (MHz)	P <sub>Mea</sub> (dBm)	P <sub>cl</sub> (dB)	Diatance	G <sub>a</sub> Antenna Gain(dB)	Peak EIRP (dBm)	Limit (dBm)	Margin (dB)	Polarization
3720.0	-40.75	5.32	3.00	10.03	-36.04	-13.00	-23.04	H
5580.0	-44.30	6.19	3.00	11.41	-39.08	-13.00	-26.08	H
3720.0	-31.61	5.32	3.00	10.03	-26.90	-13.00	-13.90	V
5580.0	-34.12	6.19	3.00	11.41	-28.90	-13.00	-15.90	V

*LTE FDD Band 2 Channel Bandwidth 20MHz QPSK High Channel*

Frequency (MHz)	P <sub>Mea</sub> (dBm)	P <sub>cl</sub> (dB)	Diatance	G <sub>a</sub> Antenna Gain(dB)	Peak EIRP (dBm)	Limit (dBm)	Margin (dB)	Polarization
3800.0	-38.83	5.36	3.00	9.62	-34.57	-13.00	-21.57	H
5700.0	-44.12	6.24	3.00	11.46	-38.90	-13.00	-25.90	H
3800.0	-28.64	5.36	3.00	9.62	-24.38	-13.00	-11.38	V
5700.0	-33.89	6.24	3.00	11.46	-28.67	-13.00	-15.67	V

*LTE FDD Band 2 Channel Bandwidth 20MHz 16QAM Low Channel*

Frequency (MHz)	P <sub>Mea</sub> (dBm)	P <sub>cl</sub> (dB)	Diatance	G <sub>a</sub> Antenna Gain(dB)	Peak EIRP (dBm)	Limit (dBm)	Margin (dB)	Polarization
3715.0	-41.05	5.26	3.00	9.88	-36.43	-13.00	-23.43	H
5572.5	-46.37	6.11	3.00	11.36	-41.12	-13.00	-28.12	H
3715.0	-31.18	5.26	3.00	9.88	-26.56	-13.00	-13.56	V
5572.5	-41.67	6.11	3.00	11.36	-36.42	-13.00	-23.42	V

*LTE FDD Band 2 Channel Bandwidth 20MHz 16QAM Middle Channel*

Frequency (MHz)	P <sub>Mea</sub> (dBm)	P <sub>cl</sub> (dB)	Diatance	G <sub>a</sub> Antenna Gain(dB)	Peak EIRP (dBm)	Limit (dBm)	Margin (dB)	Polarization
3720.0	-40.52	5.32	3.00	10.03	-35.81	-13.00	-22.81	H
5580.0	-46.29	6.19	3.00	11.41	-41.07	-13.00	-28.07	H
3720.0	-34.93	5.32	3.00	10.03	-30.22	-13.00	-17.22	V
5580.0	-39.29	6.19	3.00	11.41	-34.07	-13.00	-21.07	V

*LTE FDD Band 2 Channel Bandwidth 20MHz 16QAM High Channel*

Frequency (MHz)	P <sub>Mea</sub> (dBm)	P <sub>cl</sub> (dB)	Diatance	G <sub>a</sub> Antenna Gain(dB)	Peak EIRP (dBm)	Limit (dBm)	Margin (dB)	Polarization
3800.0	-41.82	5.36	3.00	9.62	-37.56	-13.00	-24.56	H
5700.0	-48.72	6.24	3.00	11.46	-43.50	-13.00	-30.50	H
3800.0	-32.73	5.36	3.00	9.62	-28.47	-13.00	-15.47	V
5700.0	-38.46	6.24	3.00	11.46	-33.24	-13.00	-20.24	V

*LTE FDD Band 4 Channel Bandwidth 20MHz QPSK Low Channel*

Frequency (MHz)	P <sub>Mea</sub> (dBm)	P <sub>cl</sub> (dB)	Diatance	G <sub>a</sub> Antenna Gain(dB)	Peak EIRP (dBm)	Limit (dBm)	Margin (dB)	Polarization
3440.0	-41.61	4.62	3.00	9.81	-36.42	-13.00	-23.42	H
5160.0	-46.26	5.94	3.00	10.86	-41.34	-13.00	-28.34	H
3440.0	-35.86	4.62	3.00	9.81	-30.67	-13.00	-17.67	V
5160.0	-38.93	5.94	3.00	10.86	-34.01	-13.00	-21.01	V

*LTE FDD Band 4 Channel Bandwidth 20MHz QPSK Middle Channel*

Frequency (MHz)	P <sub>Mea</sub> (dBm)	P <sub>cl</sub> (dB)	Diatance	G <sub>a</sub> Antenna Gain(dB)	Peak EIRP (dBm)	Limit (dBm)	Margin (dB)	Polarization
3465.0	-43.88	4.63	3.00	9.84	-38.67	-13.00	-25.67	H
5197.5	-45.99	5.94	3.00	10.86	-41.07	-13.00	-28.07	H
3465.0	-34.09	4.63	3.00	9.84	-28.88	-13.00	-15.88	V
5197.5	-40.16	5.94	3.00	10.86	-35.24	-13.00	-22.24	V

*LTE FDD Band 4 Channel Bandwidth 20MHz QPSK High Channel*

Frequency (MHz)	P <sub>Mea</sub> (dBm)	P <sub>cl</sub> (dB)	Diatance	G <sub>a</sub> Antenna Gain(dB)	Peak EIRP (dBm)	Limit (dBm)	Margin (dB)	Polarization
3490.0	-43.75	4.65	3.00	9.9	-38.50	-13.00	-25.50	H
5235.0	-45.57	5.95	3.00	10.91	-40.61	-13.00	-27.61	H
3490.0	-34.66	4.65	3.00	9.9	-29.41	-13.00	-16.41	V
5235.0	-40.84	5.95	3.00	10.91	-35.88	-13.00	-22.88	V

*LTE FDD Band 4 Channel Bandwidth 20MHz 16QAM Low Channel*

Frequency (MHz)	P <sub>Mea</sub> (dBm)	P <sub>cl</sub> (dB)	Diatance	G <sub>a</sub> Antenna Gain(dB)	Peak EIRP (dBm)	Limit (dBm)	Margin (dB)	Polarization
3440.0	-44.41	4.62	3.00	9.81	-39.22	-13.00	-26.22	H
5160.0	-49.22	5.94	3.00	10.86	-44.30	-13.00	-31.30	H
3440.0	-37.86	4.62	3.00	9.81	-32.67	-13.00	-19.67	V
5160.0	-44.63	5.94	3.00	10.86	-39.71	-13.00	-26.71	V

*LTE FDD Band 4 Channel Bandwidth 20MHz 16QAM Middle Channel*

Frequency (MHz)	P <sub>Mea</sub> (dBm)	P <sub>cl</sub> (dB)	Diatance	G <sub>a</sub> Antenna Gain(dB)	Peak EIRP (dBm)	Limit (dBm)	Margin (dB)	Polarization
3465.0	-43.34	4.63	3.00	9.84	-38.13	-13.00	-25.13	H
5197.5	-51.71	5.94	3.00	10.86	-46.79	-13.00	-33.79	H
3465.0	-39.14	4.63	3.00	9.84	-33.93	-13.00	-20.93	V
5197.5	-44.05	5.94	3.00	10.86	-39.13	-13.00	-26.13	V

*LTE FDD Band 4 Channel Bandwidth 20MHz 16QAM High Channel*

Frequency (MHz)	P <sub>Mea</sub> (dBm)	P <sub>cl</sub> (dB)	Diatance	G <sub>a</sub> Antenna Gain(dB)	Peak EIRP (dBm)	Limit (dBm)	Margin (dB)	Polarization
3490.0	-44.62	4.65	3.00	9.9	-39.37	-13.00	-26.37	H
5235.0	-48.77	5.95	3.00	10.91	-43.81	-13.00	-30.81	H
3490.0	-38.97	4.65	3.00	9.9	-33.72	-13.00	-20.72	V
5235.0	-43.34	5.95	3.00	10.91	-38.38	-13.00	-25.38	V

*LTE FDD Band 5 Channel Bandwidth 10MHz QPSK Low Channel*

Frequency (MHz)	P <sub>Mea</sub> (dBm)	P <sub>cl</sub> (dB)	Diatance	G <sub>a</sub> Antenna Gain(dB)	Peak EIRP (dBm)	Limit (dBm)	Margin (dB)	Polarization
1658.00	-38.75	3.86	3.00	8.56	-34.05	-13.00	-21.05	H
2487.00	-44.67	4.29	3.00	6.98	-41.98	-13.00	-28.98	H
1658.00	-33.06	3.86	3.00	8.56	-28.36	-13.00	-15.36	V
2487.00	-38.17	4.29	3.00	6.98	-35.48	-13.00	-22.48	V

*LTE FDD Band 5 Channel Bandwidth 10MHz QPSK Middle Channel*

Frequency (MHz)	P <sub>Mea</sub> (dBm)	P <sub>cl</sub> (dB)	Diatance	G <sub>a</sub> Antenna Gain(dB)	Peak EIRP (dBm)	Limit (dBm)	Margin (dB)	Polarization
1673.00	-39.20	3.9	3.00	8.58	-34.52	-13.00	-21.52	H
2509.50	-47.37	4.32	3.00	6.8	-44.89	-13.00	-31.89	H
1673.00	-35.56	3.9	3.00	8.58	-30.88	-13.00	-17.88	V
2509.50	-39.96	4.32	3.00	6.8	-37.48	-13.00	-24.48	V

*LTE FDD Band 5 Channel Bandwidth 10MHz QPSK High Channel*

Frequency (MHz)	P <sub>Mea</sub> (dBm)	P <sub>cl</sub> (dB)	Diatance	G <sub>a</sub> Antenna Gain(dB)	Peak EIRP (dBm)	Limit (dBm)	Margin (dB)	Polarization
1688.00	-39.57	3.91	3.00	9.06	-34.42	-13.00	-21.42	H
2532.00	-47.04	4.32	3.00	6.65	-44.71	-13.00	-31.71	H
1688.00	-33.49	3.91	3.00	9.06	-28.34	-13.00	-15.34	V
2532.00	-39.56	4.32	3.00	6.65	-37.23	-13.00	-24.23	V

*LTE FDD Band 5 Channel Bandwidth 10MHz 16QAM Low Channel*

Frequency (MHz)	P <sub>Mea</sub> (dBm)	P <sub>cl</sub> (dB)	Diatance	G <sub>a</sub> Antenna Gain(dB)	Peak EIRP (dBm)	Limit (dBm)	Margin (dB)	Polarization
1658.00	-43.96	3.86	3.00	8.56	-39.26	-13.00	-26.26	H
2487.00	-48.45	4.29	3.00	6.98	-45.76	-13.00	-32.76	H
1658.00	-37.12	3.86	3.00	8.56	-32.42	-13.00	-19.42	V
2487.00	-40.45	4.29	3.00	6.98	-37.76	-13.00	-24.76	V

*LTE FDD Band 5 Channel Bandwidth 10MHz 16QAM Middle Channel*

Frequency (MHz)	P <sub>Mea</sub> (dBm)	P <sub>cl</sub> (dB)	Diatance	G <sub>a</sub> Antenna Gain(dB)	Peak EIRP (dBm)	Limit (dBm)	Margin (dB)	Polarization
1673.00	-43.18	3.9	3.00	8.58	-38.50	-13.00	-25.50	H
2509.50	-47.65	4.32	3.00	6.8	-45.17	-13.00	-32.17	H
1673.00	-36.46	3.9	3.00	8.58	-31.78	-13.00	-18.78	V
2509.50	-39.01	4.32	3.00	6.8	-36.53	-13.00	-23.53	V

*LTE FDD Band 5 Channel Bandwidth 10MHz 16QAM High Channel*

Frequency (MHz)	P <sub>Mea</sub> (dBm)	P <sub>cl</sub> (dB)	Diatance	G <sub>a</sub> Antenna Gain(dB)	Peak EIRP (dBm)	Limit (dBm)	Margin (dB)	Polarization
1688.00	-43.65	3.91	3.00	9.06	-38.50	-13.00	-25.50	H
2532.00	-48.48	4.32	3.00	6.65	-46.15	-13.00	-33.15	H
1688.00	-39.82	3.91	3.00	9.06	-34.67	-13.00	-21.67	V
2532.00	-39.59	4.32	3.00	6.65	-37.26	-13.00	-24.26	V

*LTE FDD Band 12 Channel Bandwidth 10MHz QPSK Low Channel*

Frequency (MHz)	P <sub>Mea</sub> (dBm)	P <sub>cl</sub> (dB)	Diatance	G <sub>a</sub> Antenna Gain(dB)	Peak EIRP (dBm)	Limit (dBm)	Margin (dB)	Polarization
1408.00	-40.77	3.71	3.00	9.02	-35.46	-13.00	-22.46	H
2112.00	-46.81	4.22	3.00	8.64	-42.39	-13.00	-29.39	H
1408.00	-36.40	3.71	3.00	9.02	-31.09	-13.00	-18.09	V
2112.00	-36.83	4.22	3.00	8.64	-32.41	-13.00	-19.41	V

*LTE FDD Band 12 Channel Bandwidth 10MHz QPSK Middle Channel*

Frequency (MHz)	P <sub>Mea</sub> (dBm)	P <sub>cl</sub> (dB)	Diatance	G <sub>a</sub> Antenna Gain(dB)	Peak EIRP (dBm)	Limit (dBm)	Margin (dB)	Polarization
1415.00	-39.48	3.72	3.00	9.04	-34.16	-13.00	-21.16	H
2122.50	-45.44	4.23	3.00	8.6	-41.07	-13.00	-28.07	H
1415.00	-33.08	3.72	3.00	9.04	-27.76	-13.00	-14.76	V
2122.50	-39.66	4.23	3.00	8.6	-35.29	-13.00	-22.29	V

*LTE FDD Band 12 Channel Bandwidth 10MHz QPSK High Channel*

Frequency (MHz)	P <sub>Mea</sub> (dBm)	P <sub>cl</sub> (dB)	Diatance	G <sub>a</sub> Antenna Gain(dB)	Peak EIRP (dBm)	Limit (dBm)	Margin (dB)	Polarization
1422.00	-41.28	4.78	3.00	8.91	-37.15	-13.00	-24.15	H
2133.00	-46.67	4.25	3.00	8.26	-42.66	-13.00	-29.66	H
1422.00	-36.20	4.78	3.00	8.91	-32.07	-13.00	-19.07	V
2133.00	-39.07	4.25	3.00	8.26	-35.06	-13.00	-22.06	V

*LTE FDD Band 12 Channel Bandwidth 10MHz 16QAM Low Channel*

Frequency (MHz)	P <sub>Mea</sub> (dBm)	P <sub>cl</sub> (dB)	Diatance	G <sub>a</sub> Antenna Gain(dB)	Peak EIRP (dBm)	Limit (dBm)	Margin (dB)	Polarization
1408.00	-40.81	3.71	3.00	9.02	-35.50	-13.00	-22.50	H
2112.00	-45.92	4.22	3.00	8.64	-41.50	-13.00	-28.50	H
1408.00	-35.21	3.71	3.00	9.02	-29.90	-13.00	-16.90	V
2112.00	-39.78	4.22	3.00	8.64	-35.36	-13.00	-22.36	V

*LTE FDD Band 12 Channel Bandwidth 10MHz 16QAM Middle Channel*

Frequency (MHz)	P <sub>Mea</sub> (dBm)	P <sub>cl</sub> (dB)	Diatance	G <sub>a</sub> Antenna Gain(dB)	Peak EIRP (dBm)	Limit (dBm)	Margin (dB)	Polarization
1415.00	-41.49	3.72	3.00	9.04	-36.17	-13.00	-23.17	H
2122.50	-44.66	4.23	3.00	8.6	-40.29	-13.00	-27.29	H
1415.00	-36.90	3.72	3.00	9.04	-31.58	-13.00	-18.58	V
2122.50	-37.71	4.23	3.00	8.6	-33.34	-13.00	-20.34	V

*LTE FDD Band 12 Channel Bandwidth 10MHz 16QAM High Channel*

Frequency (MHz)	P <sub>Mea</sub> (dBm)	P <sub>cl</sub> (dB)	Diatance	G <sub>a</sub> Antenna Gain(dB)	Peak EIRP (dBm)	Limit (dBm)	Margin (dB)	Polarization
1422.00	-39.12	4.78	3.00	8.91	-34.99	-13.00	-21.99	H
2133.00	-46.97	4.25	3.00	8.26	-42.96	-13.00	-29.96	H
1422.00	-34.42	4.78	3.00	8.91	-30.29	-13.00	-17.29	V
2133.00	-36.73	4.25	3.00	8.26	-32.72	-13.00	-19.72	V

*LTE FDD Band 13 Channel Bandwidth 10MHz QPSK Middle Channel*

Frequency (MHz)	P <sub>Mea</sub> (dBm)	P <sub>cl</sub> (dB)	Diatance	G <sub>a</sub> Antenna Gain(dB)	Peak EIRP (dBm)	Limit (dBm)	Margin (dB)	Polarization
1564.0	-59.98	4.99	3.00	11.12	-53.85	-40.00	-13.85	H
2346.0	-47.42	5.85	3.00	12.02	-41.25	-13.00	-28.25	H
1564.0	-61.92	4.99	3.00	11.12	-55.79	-40.00	-15.79	V
2346.0	-38.14	5.85	3.00	12.02	-31.97	-13.00	-18.97	V

*LTE FDD Band 13 Channel Bandwidth 10MHz 16QAM Middle Channel*

Frequency (MHz)	P <sub>Mea</sub> (dBm)	P <sub>cl</sub> (dB)	Diatance	G <sub>a</sub> Antenna Gain(dB)	Peak EIRP (dBm)	Limit (dBm)	Margin (dB)	Polarization
1564.0	-60.17	4.99	3.00	11.12	-54.04	-40.00	-14.04	H
2346.0	-45.15	5.85	3.00	12.02	-38.98	-13.00	-25.98	H
1564.0	-61.00	4.99	3.00	11.12	-54.87	-40.00	-14.87	V
2346.0	-37.24	5.85	3.00	12.02	-31.07	-13.00	-18.07	V

*LTE FDD Band 25 Channel Bandwidth 20MHz QPSK Low Channel*

Frequency (MHz)	P <sub>Mea</sub> (dBm)	P <sub>cl</sub> (dB)	Diatance	G <sub>a</sub> Antenna Gain(dB)	Peak EIRP (dBm)	Limit (dBm)	Margin (dB)	Polarization
3715.0	-44.15	5.26	3.00	9.88	-39.53	-13.00	-26.53	H
5572.5	-52.38	6.11	3.00	11.36	-47.13	-13.00	-34.13	H
3715.0	-44.28	5.26	3.00	9.88	-39.66	-13.00	-26.66	V
5572.5	-46.23	6.11	3.00	11.36	-40.98	-13.00	-27.98	V

*LTE FDD Band 25 Channel Bandwidth 20MHz QPSK Middle Channel*

Frequency (MHz)	P <sub>Mea</sub> (dBm)	P <sub>cl</sub> (dB)	Diatance	G <sub>a</sub> Antenna Gain(dB)	Peak EIRP (dBm)	Limit (dBm)	Margin (dB)	Polarization
3765.0	-40.29	5.32	3.00	10.03	-35.58	-13.00	-22.58	H
5647.5	-51.85	6.19	3.00	11.41	-46.63	-13.00	-33.63	H
3765.0	-42.06	5.32	3.00	10.03	-37.35	-13.00	-24.35	V
5647.5	-50.27	6.19	3.00	11.41	-45.05	-13.00	-32.05	V

*LTE FDD Band 25 Channel Bandwidth 20MHz QPSK High Channel*

Frequency (MHz)	P <sub>Mea</sub> (dBm)	P <sub>cl</sub> (dB)	Diatance	G <sub>a</sub> Antenna Gain(dB)	Peak EIRP (dBm)	Limit (dBm)	Margin (dB)	Polarization
3810.0	-41.38	5.36	3.00	9.62	-37.12	-13.00	-24.12	H
5715.0	-47.19	6.24	3.00	11.46	-41.97	-13.00	-28.97	H
3810.0	-45.23	5.36	3.00	9.62	-40.97	-13.00	-27.97	V
5715.0	-47.98	6.24	3.00	11.46	-42.76	-13.00	-29.76	V

*LTE FDD Band 25 Channel Bandwidth 20MHz 16QAM Low Channel*

Frequency (MHz)	P <sub>Mea</sub> (dBm)	P <sub>cl</sub> (dB)	Diatance	G <sub>a</sub> Antenna Gain(dB)	Peak EIRP (dBm)	Limit (dBm)	Margin (dB)	Polarization
3715.0	-42.06	5.26	3.00	9.88	-37.44	-13.00	-24.44	H
5572.5	-53.72	6.11	3.00	11.36	-48.47	-13.00	-35.47	H
3715.0	-45.06	5.26	3.00	9.88	-40.44	-13.00	-27.44	V
5572.5	-50.39	6.11	3.00	11.36	-45.14	-13.00	-32.14	V

*LTE FDD Band 25 Channel Bandwidth 20MHz 16QAM Middle Channel*

Frequency (MHz)	P <sub>Mea</sub> (dBm)	P <sub>cl</sub> (dB)	Diatance	G <sub>a</sub> Antenna Gain(dB)	Peak EIRP (dBm)	Limit (dBm)	Margin (dB)	Polarization
3765.0	-41.27	5.32	3.00	10.03	-36.56	-13.00	-23.56	H
5647.5	-54.14	6.19	3.00	11.41	-48.92	-13.00	-35.92	H
3765.0	-41.08	5.32	3.00	10.03	-36.37	-13.00	-23.37	V
5647.5	-48.78	6.19	3.00	11.41	-43.56	-13.00	-30.56	V

*LTE FDD Band 25 Channel Bandwidth 20MHz 16QAM High Channel*

Frequency (MHz)	P <sub>Mea</sub> (dBm)	P <sub>cl</sub> (dB)	Diatance	G <sub>a</sub> Antenna Gain(dB)	Peak EIRP (dBm)	Limit (dBm)	Margin (dB)	Polarization
3810.0	-42.20	5.36	3.00	9.62	-37.94	-13.00	-24.94	H
5715.0	-48.91	6.24	3.00	11.46	-43.69	-13.00	-30.69	H
3810.0	-43.95	5.36	3.00	9.62	-39.69	-13.00	-26.69	V
5715.0	-50.64	6.24	3.00	11.46	-45.42	-13.00	-32.42	V

**LTE FDD Band 26: 814-824MHz***LTE FDD Band 26 Channel Bandwidth 10MHz QPSK Middle Channel*

Frequency (MHz)	P <sub>Mea</sub> (dBm)	P <sub>cl</sub> (dB)	Diatance	G <sub>a</sub> Antenna Gain(dB)	Peak EIRP (dBm)	Limit (dBm)	Margin (dB)	Polarization
1638.0	-38.59	3.86	3.00	8.56	-33.89	-13.00	-20.89	H
2457.0	-46.39	4.29	3.00	6.98	-43.70	-13.00	-30.70	H
1638.0	-33.67	3.86	3.00	8.56	-28.97	-13.00	-15.97	V
2457.0	-36.21	4.29	3.00	6.98	-33.52	-13.00	-20.52	V

*LTE FDD Band 26 Channel Bandwidth 10MHz 16QAM Middle Channel*

Frequency (MHz)	P <sub>Mea</sub> (dBm)	P <sub>cl</sub> (dB)	Diatance	G <sub>a</sub> Antenna Gain(dB)	Peak EIRP (dBm)	Limit (dBm)	Margin (dB)	Polarization
1638.0	-39.86	3.86	3.00	8.56	-35.16	-13.00	-22.16	H
2457.0	-45.49	4.29	3.00	6.98	-42.80	-13.00	-29.80	H
1638.0	-35.65	3.86	3.00	8.56	-30.95	-13.00	-17.95	V
2457.0	-36.30	4.29	3.00	6.98	-33.61	-13.00	-20.61	V

**LTE FDD Band 26: 824-849MHz***LTE FDD Band 26 Channel Bandwidth 15MHz QPSK Low Channel*

Frequency (MHz)	P <sub>Mea</sub> (dBm)	P <sub>cl</sub> (dB)	Diatance	G <sub>a</sub> Antenna Gain(dB)	Peak EIRP (dBm)	Limit (dBm)	Margin (dB)	Polarization
1663.0	-41.47	3.86	3.00	8.56	-36.77	-13.00	-23.77	H
2494.5	-46.46	4.29	3.00	6.98	-43.77	-13.00	-30.77	H
1663.0	-35.14	3.86	3.00	8.56	-30.44	-13.00	-17.44	V
2494.5	-37.92	4.29	3.00	6.98	-35.23	-13.00	-22.23	V

*LTE FDD Band 26 Channel Bandwidth 15MHz QPSK Middle Channel*

Frequency (MHz)	P <sub>Mea</sub> (dBm)	P <sub>cl</sub> (dB)	Diatance	G <sub>a</sub> Antenna Gain(dB)	Peak EIRP (dBm)	Limit (dBm)	Margin (dB)	Polarization
1673.0	-41.89	3.90	3.00	8.58	-37.21	-13.00	-24.21	H
2509.5	-45.87	4.32	3.00	6.80	-43.39	-13.00	-30.39	H
1673.0	-34.14	3.90	3.00	8.58	-29.46	-13.00	-16.46	V
2509.5	-38.72	4.32	3.00	6.80	-36.24	-13.00	-23.24	V

*LTE FDD Band 26 Channel Bandwidth 15MHz QPSK High Channel*

Frequency (MHz)	P <sub>Mea</sub> (dBm)	P <sub>cl</sub> (dB)	Diatance	G <sub>a</sub> Antenna Gain(dB)	Peak EIRP (dBm)	Limit (dBm)	Margin (dB)	Polarization
1683.0	-39.88	3.91	3.00	9.06	-34.73	-13.00	-21.73	H
2524.5	-47.90	4.32	3.00	6.65	-45.57	-13.00	-32.57	H
1683.0	-34.51	3.91	3.00	9.06	-29.36	-13.00	-16.36	V
2524.5	-37.54	4.32	3.00	6.65	-35.21	-13.00	-22.21	V

*LTE FDD Band 26 Channel Bandwidth 15MHz 16QAM Low Channel*

Frequency (MHz)	P <sub>Mea</sub> (dBm)	P <sub>cl</sub> (dB)	Diatance	G <sub>a</sub> Antenna Gain(dB)	Peak EIRP (dBm)	Limit (dBm)	Margin (dB)	Polarization
1663.0	-41.61	3.86	3.00	8.56	-36.91	-13.00	-23.91	H
2494.5	-47.55	4.29	3.00	6.98	-44.86	-13.00	-31.86	H
1663.0	-39.33	3.86	3.00	8.56	-34.63	-13.00	-21.63	V
2494.5	-40.40	4.29	3.00	6.98	-37.71	-13.00	-24.71	V

*LTE FDD Band 26 Channel Bandwidth 15MHz 16QAM Middle Channel*

Frequency (MHz)	P <sub>Mea</sub> (dBm)	P <sub>cl</sub> (dB)	Diatance	G <sub>a</sub> Antenna Gain(dB)	Peak EIRP (dBm)	Limit (dBm)	Margin (dB)	Polarization
1673.0	-44.06	3.90	3.00	8.58	-39.38	-13.00	-26.38	H
2509.5	-48.13	4.32	3.00	6.80	-45.65	-13.00	-32.65	H
1673.0	-38.12	3.90	3.00	8.58	-33.44	-13.00	-20.44	V
2509.5	-40.18	4.32	3.00	6.80	-37.70	-13.00	-24.70	V

*LTE FDD Band 26 Channel Bandwidth 15MHz 16QAM High Channel*

Frequency (MHz)	P <sub>Mea</sub> (dBm)	P <sub>cl</sub> (dB)	Diatance	G <sub>a</sub> Antenna Gain(dB)	Peak EIRP (dBm)	Limit (dBm)	Margin (dB)	Polarization
1683.0	-42.98	3.91	3.00	9.06	-37.83	-13.00	-24.83	H
2524.5	-47.31	4.32	3.00	6.65	-44.98	-13.00	-31.98	H
1683.0	-38.53	3.91	3.00	9.06	-33.38	-13.00	-20.38	V
2524.5	-41.32	4.32	3.00	6.65	-38.99	-13.00	-25.99	V

Notes: All channel bandwidth were tested, the report recorded the worst data.



## 4.6 Frequency Stability under Temperature & Voltage Variations

### LIMIT

According to FCC §2.1055, §22.355, §24.235, §27.54, § 90.539 requirement, the frequency stability shall be sufficient to ensure that the fundamental emissions stay within the authorized bands of operation and should not exceed 2.5ppm.

### TEST CONFIGURATION

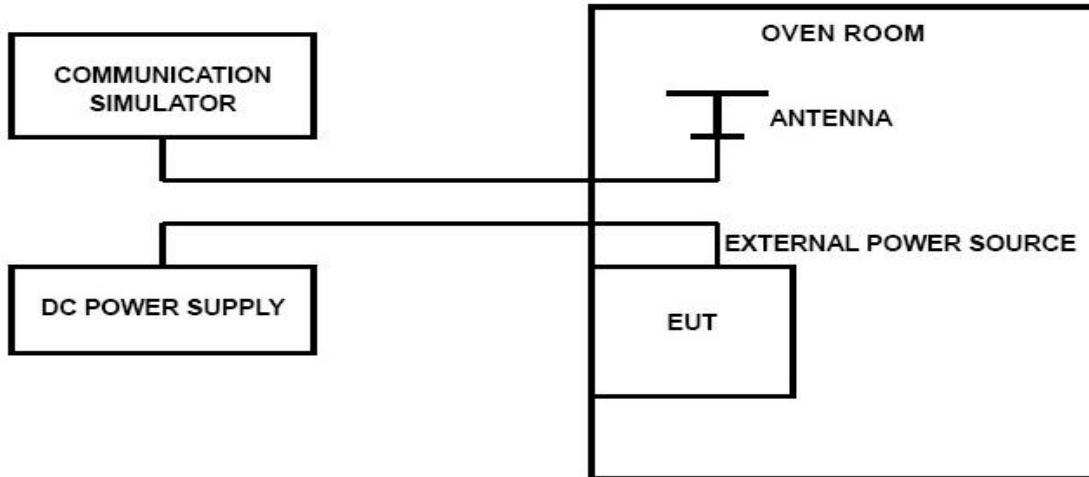

### TEST PROCEDURE

The EUT was setup according to TIA-603-E

#### **Frequency Stability Under Temperature Variations:**

In order to measure the carrier frequency under the condition of AFC lock, it is necessary to make measurements with the EUT in a “call mode”. This is accomplished with the use of R&S CMW 500 DIGITAL RADIO COMMUNICATION TESTER.

1. Measure the carrier frequency at room temperature.
2. Subject the EUT to overnight soak at -30°C.
3. With the EUT, powered via nominal voltage, connected to the CMW 500 and in a simulated call on middle channel for LTE LTE band 4; measure the carrier frequency. These measurements should be made within 2 minutes of Powering up the EUT, to prevent significant self-warming.
4. Repeat the above measurements at 10°C increments from -30°C to +50°C. Allow at least 1.5 hours at each temperature, unpowered, before making measurements.
5. Re-measure carrier frequency at room temperature with nominal voltage. Vary supply voltage from minimum voltage to maximum voltage, in 0.1 Volt increments re-measuring carrier frequency at each voltage. Pause at nominal voltage for 1.5 hours unpowered, to allow any self-heating to stabilize, before continuing.
6. Subject the EUT to overnight soak at +50°C.
7. With the EUT, powered via nominal voltage, connected to the CMW 500 and in a simulated call on the centre channel, measure the carrier frequency. These measurements should be made within 2 minutes of Powering up the EUT, to prevent significant self-warming.
8. Repeat the above measurements at 10 °C increments from +50°C to -30°C. Allow at least 1.5 hours at each temperature, unpowered, before making measurements
9. At all temperature levels hold the temperature to +/- 0.5°C during the measurement procedure.

#### **Frequency Stability Under Voltage Variations:**

Set chamber temperature to 20°C. Use a variable AC power supply / DC power source to power the EUT and set the voltage to rated voltage. Set the spectrum analyzer RBW low enough to obtain the desired frequency resolution and recorded the frequency.

Reduce the input voltage to specify extreme voltage variation (±15%) and endpoint, record the maximum frequency change.



**TEST RESULTS**

*Remark:*

*We were tested all RB Configuration refer 3GPP TS136 521 for each Channel Bandwidth of LTE FDD Band 2, LTE FDD Band 4, LTE FDD Band 5, LTE FDD Band 12, LTE FDD Band 13, LTE FDD Band 25, LTE FDD Band 26; recorded worst case for each Channel Bandwidth of LTE FDD Band 2, LTE FDD Band 4, LTE FDD Band 5, LTE FDD Band 12, LTE FDD Band 13, LTE FDD Band 25, LTE FDD Band 26.*

*LTE Band 2, QPSK, 1.4MHz bandwidth (worst case of all bandwidths)*

<i>LTE FDD Band 2</i>					
DC Power	Temperature (°C)	Frequency error(Hz)	Frequency error(ppm)	Limit (ppm)	Verdict
5	20	4	0.002	±2.50	PASS
6	20	-10	-0.005	±2.50	PASS
7	20	-10	-0.005	±2.50	PASS
6	0	-13	-0.007	±2.50	PASS
6	10	19	0.010	±2.50	PASS
6	20	8	0.004	±2.50	PASS
6	30	18	0.010	±2.50	PASS
6	40	11	0.006	±2.50	PASS
6	50	18	0.010	±2.50	PASS
6	20	-17	-0.009	±2.50	PASS
6	20	-14	-0.007	±2.50	PASS
6	20	-16	-0.009	±2.50	PASS

*LTE Band 2, 16QAM, 1.4MHz bandwidth (worst case of all bandwidths)*

<i>LTE FDD Band 2</i>					
DC Power	Temperature (°C)	Frequency error(Hz)	Frequency error(ppm)	Limit (ppm)	Verdict
5	20	1	0.001	±2.50	PASS
6	20	19	0.010	±2.50	PASS
7	20	-8	-0.004	±2.50	PASS
6	0	-14	-0.007	±2.50	PASS
6	10	-7	-0.004	±2.50	PASS
6	20	16	0.009	±2.50	PASS
6	30	-7	-0.004	±2.50	PASS
6	40	10	0.005	±2.50	PASS
6	50	-10	-0.005	±2.50	PASS
6	20	10	0.005	±2.50	PASS
6	20	19	0.010	±2.50	PASS
6	20	-14	-0.007	±2.50	PASS

*LTE Band 4, QPSK, 1.4MHz bandwidth (worst case of all bandwidths)*

LTE FDD Band 4					
DC Power	Temperature (°C)	Frequency error(Hz)	Frequency error(ppm)	Limit (ppm)	Verdict
5	20	-21	-0.012	±2.50	PASS
6	20	15	0.009	±2.50	PASS
7	20	-8	-0.005	±2.50	PASS
6	0	-8	-0.005	±2.50	PASS
6	10	-38	-0.022	±2.50	PASS
6	20	-18	-0.010	±2.50	PASS
6	30	25	0.014	±2.50	PASS
6	40	5	0.003	±2.50	PASS
6	50	-40	-0.023	±2.50	PASS
6	20	-36	-0.021	±2.50	PASS
6	20	5	0.003	±2.50	PASS
6	20	-25	-0.014	±2.50	PASS

*LTE Band 4, 16QAM, 1.4MHz bandwidth (worst case of all bandwidths)*

LTE FDD Band 4					
DC Power	Temperature (°C)	Frequency error(Hz)	Frequency error(ppm)	Limit (ppm)	Verdict
5	20	19	0.011	±2.50	PASS
6	20	-25	-0.014	±2.50	PASS
7	20	2	0.001	±2.50	PASS
6	0	-44	-0.025	±2.50	PASS
6	10	2	0.001	±2.50	PASS
6	20	18	0.010	±2.50	PASS
6	30	-9	-0.005	±2.50	PASS
6	40	27	0.015	±2.50	PASS
6	50	44	0.025	±2.50	PASS
6	20	41	0.023	±2.50	PASS
6	20	0	0.000	±2.50	PASS
6	20	20	0.011	±2.50	PASS

*LTE Band 5, QPSK, 1.4MHz bandwidth(worst case of all bandwidths)*

LTE FDD Band 5					
DC Power	Temperature (°C)	Frequency error(Hz)	Frequency error(ppm)	Limit (ppm)	Verdict
5	20	-48	-0.058	±2.50	PASS
6	20	9	0.011	±2.50	PASS
7	20	2	0.002	±2.50	PASS
6	0	-24	-0.029	±2.50	PASS
6	10	45	0.055	±2.50	PASS
6	20	43	0.052	±2.50	PASS
6	30	-31	-0.038	±2.50	PASS
6	40	46	0.056	±2.50	PASS
6	50	-33	-0.040	±2.50	PASS
6	20	46	0.056	±2.50	PASS
6	20	-5	-0.006	±2.50	PASS
6	20	-5	-0.006	±2.50	PASS

*LTE Band 5, 16QAM, 1.4MHz bandwidth(worst case of all bandwidths)*

LTE FDD Band 5					
DC Power	Temperature (°C)	Frequency error(Hz)	Frequency error(ppm)	Limit (ppm)	Verdict
5	20	-8	-0.010	±2.50	PASS
6	20	47	0.057	±2.50	PASS
7	20	17	0.021	±2.50	PASS
6	0	6	0.007	±2.50	PASS
6	10	-34	-0.041	±2.50	PASS
6	20	-12	-0.015	±2.50	PASS
6	30	12	0.015	±2.50	PASS
6	40	-48	-0.058	±2.50	PASS
6	50	21	0.025	±2.50	PASS
6	20	27	0.033	±2.50	PASS
6	20	40	0.049	±2.50	PASS
6	20	46	0.056	±2.50	PASS

*LTE Band 12, QPSK, 1.4MHz bandwidth (worst case of all bandwidths and modulation type)*

LTE FDD Band 12					
DC Power	Temperature (°C)	Frequency error(Hz)	Frequency error(ppm)	Limit (ppm)	Verdict
5	20	-15	-0.021	±2.50	PASS
6	20	45	0.064	±2.50	PASS
7	20	-1	-0.001	±2.50	PASS
6	-30	48	0.068	±2.50	PASS
6	-20	3	0.004	±2.50	PASS
6	-10	1	0.001	±2.50	PASS
6	0	-30	-0.042	±2.50	PASS
6	10	-39	-0.055	±2.50	PASS
6	20	-36	-0.051	±2.50	PASS
6	30	35	0.049	±2.50	PASS
6	40	-22	-0.031	±2.50	PASS
6	50	39	0.055	±2.50	PASS

*LTE Band 12, 16QAM, 1.4MHz bandwidth (worst case of all bandwidths and modulation type)*

LTE FDD Band 12					
DC Power	Temperature (°C)	Frequency error(Hz)	Frequency error(ppm)	Limit (ppm)	Verdict
5	20	-5	-0.006	±2.50	PASS
6	20	-34	-0.043	±2.50	PASS
7	20	-12	-0.015	±2.50	PASS
6	-30	39	0.050	±2.50	PASS
6	-20	37	0.047	±2.50	PASS
6	-10	19	0.024	±2.50	PASS
6	0	-15	-0.019	±2.50	PASS
6	10	42	0.054	±2.50	PASS
6	20	-13	-0.017	±2.50	PASS
6	30	-27	-0.035	±2.50	PASS
6	40	32	0.041	±2.50	PASS
6	50	34	0.043	±2.50	PASS

*LTE Band 13, 5MHz bandwidth, QPSK (worst case of all bandwidths)*

<i>LTE FDD Band 13</i>					
<i>DC Power</i>	<i>Temperature (°C)</i>	<i>Frequency error(Hz)</i>	<i>Frequency error(ppm)</i>	<i>Limit (ppm)</i>	<i>Verdict</i>
5	20	-28	-0.036	2.50	PASS
6	20	-24	-0.031	2.50	PASS
7	20	39	0.050	2.50	PASS
6	-30	-45	-0.058	2.50	PASS
6	-20	-20	-0.026	2.50	PASS
6	-10	26	0.033	2.50	PASS
6	0	9	0.012	2.50	PASS
6	10	41	0.052	2.50	PASS
6	20	6	0.008	2.50	PASS
6	30	30	0.038	2.50	PASS
6	40	37	0.047	2.50	PASS
6	50	4	0.005	2.50	PASS

*LTE Band 13, 5MHz bandwidth, 16QAM (worst case of all bandwidths)*

<i>LTE FDD Band 13</i>					
<i>DC Power</i>	<i>Temperature (°C)</i>	<i>Frequency error(Hz)</i>	<i>Frequency error(ppm)</i>	<i>Limit (ppm)</i>	<i>Verdict</i>
5	20	10	0.013	2.50	PASS
6	20	25	0.032	2.50	PASS
7	20	-25	-0.032	2.50	PASS
6	-30	25	0.032	2.50	PASS
6	-20	29	0.037	2.50	PASS
6	-10	-22	-0.028	2.50	PASS
6	0	45	0.058	2.50	PASS
6	10	-23	-0.029	2.50	PASS
6	20	-48	-0.061	2.50	PASS
6	30	8	0.010	2.50	PASS
6	40	-30	-0.038	2.50	PASS
6	50	47	0.060	2.50	PASS

*LTE Band 25, 1.4MHz bandwidth, QPSK (worst case of all bandwidths)*

<i>LTE FDD Band 25</i>					
<i>DC Power</i>	<i>Temperature (°C)</i>	<i>Frequency error(Hz)</i>	<i>Frequency error(ppm)</i>	<i>Limit (ppm)</i>	<i>Verdict</i>
5	20	41	0.022	2.50	PASS
6	20	76	0.040	2.50	PASS
7	20	31	0.016	2.50	PASS
6	-30	21	0.011	2.50	PASS
6	-20	82	0.044	2.50	PASS
6	-10	1	0.001	2.50	PASS
6	0	13	0.007	2.50	PASS
6	10	81	0.043	2.50	PASS
6	20	66	0.035	2.50	PASS
6	30	64	0.034	2.50	PASS
6	40	18	0.010	2.50	PASS
6	50	11	0.006	2.50	PASS



LTE Band 25, 1.4MHz bandwidth, 16QAM (worst case of all bandwidths)

LTE FDD Band 25					
DC Power	Temperature (°C)	Frequency error(Hz)	Frequency error(ppm)	Limit (ppm)	Verdict
5	20	30	0.016	2.50	PASS
6	20	69	0.037	2.50	PASS
7	20	71	0.038	2.50	PASS
6	-30	50	0.027	2.50	PASS
6	-20	59	0.031	2.50	PASS
6	-10	38	0.020	2.50	PASS
6	0	79	0.042	2.50	PASS
6	10	72	0.038	2.50	PASS
6	20	42	0.022	2.50	PASS
6	30	83	0.044	2.50	PASS
6	40	80	0.042	2.50	PASS
6	50	20	0.011	2.50	PASS

LTE Band 26, 1.4MHz bandwidth, QPSK (worst case of all bandwidths)

LTE FDD Band 26					
DC Power	Temperature (°C)	Frequency error(Hz)	Frequency error(ppm)	Limit (ppm)	Verdict
5	20	52	0.063	2.50	PASS
6	20	88	0.107	2.50	PASS
7	20	19	0.023	2.50	PASS
6	-30	24	0.029	2.50	PASS
6	-20	62	0.076	2.50	PASS
6	-10	92	0.112	2.50	PASS
6	0	92	0.112	2.50	PASS
6	10	45	0.055	2.50	PASS
6	20	17	0.021	2.50	PASS
6	30	60	0.073	2.50	PASS
6	40	22	0.027	2.50	PASS
6	50	31	0.038	2.50	PASS

LTE Band 26, 1.4MHz bandwidth, 16QAM (worst case of all bandwidths)

LTE FDD Band 26					
DC Power	Temperature (°C)	Frequency error(Hz)	Frequency error(ppm)	Limit (ppm)	Verdict
5	20	37	0.044	2.50	PASS
6	20	64	0.077	2.50	PASS
7	20	87	0.104	2.50	PASS
6	-30	23	0.027	2.50	PASS
6	-20	78	0.093	2.50	PASS
6	-10	3	0.004	2.50	PASS
6	0	71	0.085	2.50	PASS
6	10	75	0.090	2.50	PASS
6	20	9	0.011	2.50	PASS
6	30	57	0.068	2.50	PASS
6	40	36	0.043	2.50	PASS
6	50	92	0.110	2.50	PASS



## **5 Test Setup Photos of the EUT**

Pleaserefer to separated files for Test Setup Photos of the EUT.

## **6 External Photos of the EUT**

Pleaserefer to separated files for External Photos of the EUT.

## **7 Internal Photos of the EUT**

Pleaserefer to separated files for Internal Photos of the EUT.

\*\*\*\*\***End of Report**\*\*\*\*\*