

FCC PART 24/27 TEST REPORT

FCC Part 24/Part 27

Report Reference No. : **LCS191024018AEB**

FCC ID. : **2AUZZ-AWA**

Date of Issue. : **November 11, 2019**

Testing Laboratory Name : **Shenzhen LCS Compliance Testing Laboratory Ltd.**

Address..... : 1/F., Xingyuan Industrial Park, Tongda Road, Bao'an Avenue, Bao'an District, Shenzhen, Guangdong, China

Applicant's name..... : **Covert Scouting Cameras, LLC**

Address..... : 4338 Greenridge Spa Rd, Lewisburg, KY 42256 , US

Test specification :

FCC CFR Title 47 Part 2, Part 22, Part 24, Part 27

Standard : **TIA-603-E: 2016**

KDB 971168 D01

Test Report Form No..... : LCSEMC-1.0

TRF Originator : Shenzhen LCS Compliance Testing Laboratory Ltd.

Master TRF : Dated 2011-03

Shenzhen LCS Compliance Testing Laboratory Ltd. All rights reserved.

This publication may be reproduced in whole or in part for non-commercial purposes as long as the Shenzhen LCS Compliance Testing Laboratory Ltd. is acknowledged as copyright owner and source of the material. Shenzhen LCS Compliance Testing Laboratory Ltd. takes no responsibility for and will not assume liability for damages resulting from the reader's interpretation of the reproduced material due to its placement and context.

Test item description : **AW1-A**

Trade Mark : COVERT

Test Model..... : 5466

Listed Models : N/A

Modulation Type : QPSK, 16QAM

Rating : DC 1.5V by AA battery

Hardware version : L1V50MG

Software version..... : DSP: V03; MCU: 04A4

Result..... : **PASS**

Compiled by:

Supervised by:

Approved by:

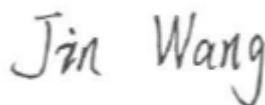
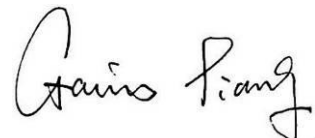
Jayden Zhuo / File administrators

Jin Wang/ Technique principal

Gavin Liang/ Manager

TEST REPORT

Test Report No. : LCS191024018AEB	November 11, 2019
	Date of issue

Equipment under Test : AW1-A

Test Model : 5466

Listed Models : N/A

Model Declaration : N/A

Applicant : **Covert Scouting Cameras, LLC**

Address : 4338 Greenridge Spa Rd, Lewisburg, KY 42256 , US

Manufacturer : **UOVision Technology (Shenzhen) Co., Ltd.**

Address : 5th and 6th Floor the first Building, shunheda Factory,
liuxiang Industrial Zone, xili Street, Nanshan District,
Shenzhen, CHN 518055

Factory : **UOVision Technology (Shenzhen) Co., Ltd.**

Address : 5th and 6th Floor the first Building, shunheda Factory,
liuxiang Industrial Zone, xili Street, Nanshan District,
Shenzhen, CHN 518055

Test Result:	PASS
---------------------	-------------

The test report merely corresponds to the test sample.
It is not permitted to copy extracts of these test result without the written permission of the test laboratory.

Revision History

Revision	Issue Date	Revisions	Revised By
000	November 11, 2019	Initial Issue	Gavin Liang

Contents

1	<u>TEST STANDARDS.....</u>	<u>5</u>
2	<u>SUMMARY.....</u>	<u>6</u>
2.1	General Remarks	6
2.2	Product Description	6
2.3	Equipment under Test	6
2.4	Short description of the Equipment under Test (EUT)	7
2.5	Internal Identification of AE used during the test	7
2.6	Normal Accessory setting	7
2.7	EUT configuration	7
2.8	Related Submittal(s) / Grant (s)	7
2.9	Modifications	7
2.10	General Test Conditions/Configurations	7
3	<u>TEST ENVIRONMENT</u>	<u>8</u>
3.1	Address of the test laboratory	8
3.2	Test Facility	8
3.3	Environmental conditions	8
3.4	Test Description	8
3.5	Equipments Used during the Test	10
3.6	Measurement uncertainty	11
4	<u>TEST CONDITIONS AND RESULTS.....</u>	<u>12</u>
4.1	Output Power	12
4.2	Peak-to-Average Ratio (PAR)	20
4.3	Occupied Bandwidth and Emission Bandwidth	21
4.4	Band Edge compliance	22
4.5	Spurious Emssion on Antenna Port	24
4.6	Radiated Spurious Emssion	26
4.7	Frequency Stability under Temperature & Voltage Variations	45
5	<u>TEST SETUP PHOTOS OF THE EUT.....</u>	<u>48</u>
6	<u>EXTERNAL PHOTOS OF THE EUT</u>	<u>48</u>
7	<u>INTERNAL PHOTOS OF THE EUT.....</u>	<u>48</u>

1 TEST STANDARDS

The tests were performed according to following standards:

[FCC Part 24\(10-1-16 Edition\)](#):PUBLIC MOBILE SERVICES

[FCC Part 27\(10-1-16 Edition\)](#):MISCELLANEOUS WIRELESS COMMUNICATIONS SERVICES

[TIA-603-E March 2016](#): Land Mobile FM or PM Communications Equipment Measurement and Performance Standards.

[47 CFR FCC Part 15 Subpart B](#): Unintentional Radiators

[FCC Part 2](#): FREQUENCY ALLOCATIONS AND RADIO TREATY MATTERS; GENERAL RULES AND REGULATIONS

[ANSI C63.4:2014](#): Methods of Measurement of Radio-Noise Emissions from Low-Voltage Electrical and Electronic Equipment in the Range of 9 kHz to 40 GHz

[FCKDB971168D01](#) Power Meas License Digital Systems

2 SUMMARY

2.1 General Remarks

Date of receipt of test sample	:	October 25, 2019
Testing commenced on	:	October 26, 2019
Testing concluded on	:	November 07, 2019

2.2 Product Description

The **Covert Scouting Cameras, LLC's** Model: 5466 or the "EUT" as referred to in this report; more general information as follows, for more details, refer to the user's manual of the EUT.

Name of EUT	AW1-A
Test Model	5466
Modulation Type	QPSK for UMTS; QPSK, 16QAM for LTE
Antenna Gain	3.0dBi for WCDMA Band II; 3.0dBi for WCDMA Band IV; 3.0dBi for WCDMA Band V; 3.0dBi for LTE Band 2; 3.0dBi for LTE Band 4; 3.0dBi for LTE Band 12;
Hardware version	L1V50MG
Software version	DSP: V03; MCU: 04A4
UMTS Operation Frequency Band	UMTS FDD Band II/IV/V
LTE Operation Frequency Band	LTE FDD band 2, 4, 12
WCDMA Release Version	R8
HSDPA Release Version	Release 8
HSUPA Release Version	Release 6
DC-HSUPA Release Version	Not Supported
LTE Release Version	R9
LTE/UMTS Power Class	Class 3
Antenna Type	External Antenna
Extreme temp. Tolerance	-20°C to +60°C
GPS function	Support and only RX
FM function	Not Supported
NFC Function	Not Supported
Extreme vol. Limits	5.4VDC to 6.6VDC (nominal: 6.0VDC)

2.3 Equipment under Test

Power supply system utilised

Power supply voltage	:	<input type="radio"/> 120V / 60 Hz	<input type="radio"/> 115V / 60Hz
		<input type="radio"/> 12 V DC	<input type="radio"/> 24 V DC
		<input checked="" type="radio"/> Other (specified in blank below) DC 6.0V	

2.4 Short description of the Equipment under Test (EUT)

2.4.1 General Description

5466 is subscriber equipment in the WCDMA/ LTE system. The HSPA/UMTS frequency band is Band II/IV/V. LTE frequency band is band 2, band 4 and band 12. The HSPA/UMTS frequency band II, Band IV and Band V test data included in this report. The AW1-A implements such functions as RF signal receiving/transmitting, HSPA/UMTS/LTE protocol processing and etc. Externally it provides SIM card interface.

NOTE: Unless otherwise noted in the report, the functional boards installed in the units shall be selected from the below list, but not means all the functional boards listed below shall be installed in one unit.

2.5 Internal Identification of AE used during the test

AE ID*	Description
AE1	Rechargeable Li-ion Battery

*AE ID: is used to identify the test sample in the lab internally.

2.6 Normal Accessory setting

Fully charged battery was used during the test.

2.7 EUT configuration

The following peripheral devices and interface cables were connected during the measurement:

- - supplied by the manufacturer
- - supplied by the lab

<input type="radio"/>	Power Cable	Length (m) :	/
		Shield :	/
		Detachable :	/
<input type="radio"/>	Multimeter	Manufacturer :	/
		Model No. :	/

2.8 Related Submittal(s) / Grant (s)

This submittal(s) (test report) is intended for **FCC ID: 2AUZZ-AWA** filing to comply with, Part 24 and Part 27 Rules

2.9 Modifications

No modifications were implemented to meet testing criteria.

2.10 General Test Conditions/Configurations

2.10.1 Test Environment

Environment Parameter	Selected Values During Tests	
Relative Humidity	Ambient	
Temperature	TN	Ambient
Voltage	VL	5.4V
	VN	6.0V
	VH	6.6V

NOTE: VL=lower extreme test voltage VN=nominal voltage
VH=upper extreme test voltage TN=normal temperature

3 TEST ENVIRONMENT

3.1 Address of the test laboratory

Shenzhen LCS Compliance Testing Laboratory Ltd

1/F., Xingyuan Industrial Park, Tongda Road, Bao'an Avenue, Bao'an District, Shenzhen, Guangdong, China

The sites are constructed in conformance with the requirements of ANSI C63.4 (2014) and CISPR Publication 22.

3.2 Test Facility

The test facility is recognized, certified, or accredited by the following organizations:

FCC Registration Number is 254912.

Industry Canada Registration Number is 9642A-1.

EMSD Registration Number is ARCB0108.

UL Registration Number is 100571-492.

TUV SUD Registration Number is SCN1081.

TUV RH Registration Number is UA 50296516-001.

NVLAP Accreditation Code is 600167-0.

FCC Designation Number is CN5024.

CAB identifier: CN0071.

3.3 Environmental conditions

During the measurement the environmental conditions were within the listed ranges:

Temperature:	15-35 ° C
Humidity:	30-60 %
Atmospheric pressure:	950-1050mbar

3.4 Test Description

3.4.1 PCS Band (1850-1915MHz pairedwith 1930-1995MHz) (band 2)

Test Item	FCC Rule No.	Requirements	Verdict
Effective(Isotropic) Radiated Output Power	§2.1046, §24.232	EIRP ≤ 2W	PASS
Peak-Average Ratio	§2.1046, §24.232	FCC:Limit≤13dB	PASS
Modulation Characteristics	§2.1047	Digital modulation	N/A
Bandwidth	§2.1049	OBW: No limit. EBW: No limit.	PASS
Band Edges Compliance	§2.1051, §24.238	≤ -13dBm/1%*EBW, In 1MHz bands immediately outside and adjacent to the frequency block.	PASS
Spurious Emission at Antenna Terminals	§2.1051, §24.238	≤-13dBm/1MHz, from 9kHz to10 th harmonics but outside authorized Operating frequency ranges.	PASS
Field Strength of Spurious Radiation	§2.1053, §24.238	≤ -13dBm/1MHz.	PASS
Frequency Stability	§2.1055, §24.235	FCC: within authorized frequency block.	PASS

NOTE 1:For the verdict, the"N/A"denotes"not applicable",the"N/T"de notes "not tested".

3.4.2 AWS Band (1710-1755MHz pairedwith 2110-2155MHz)(band 4)

Test Item	FCC RuleNo.	Requirements	Verdict
Effective(Isotropic) Radiated Power Output Data	§2.1046, §27.50(d)	EIRP ≤ 1W;	PASS
Peak-Average Ratio	§2.1046, §27.50(d)	Limit≤13dB	Pass
Modulation Characteristics	§2.1047	Digitalmodulation	N/A
Bandwidth	§2.1049	OBW: Nolimit. EBW: Nolimit.	PASS
BandEdges Compliance	§2.1051, §27.53(h)	≤ -13dBm/1%*EBW,in1 MHz bands immediately outside and adjacent to the frequency block.	PASS
Spurious Emission at Antenna Terminals	§2.1051, §27.53(h)	≤ -13dBm/1MHz, from 9kHz to10 th harmonics but outside authorized operating frequency ranges.	PASS
Frequency Stability	§2.1055, §27.54	Within authorized bands of operation/frequency block.	PASS
Radiated spurious emission	§2.1053, §27.53(h)	≤ -13dBm/1MHz.	PASS

NOTE 1: For the verdict, the "N/A" denotes "not applicable", the "N/T" de notes "not tested"

3.4.3 LSMH Band (699-716MHz paired with 729-746MHz) <LTE Band 12>

Test Item	FCC Rule No.	Requirements	Verdict
Effective(Isotropic) Radiated Power Output Data	§2.1046, §27.50(c)	ERP ≤ 3W;	PASS
Peak-Average Ratio	§2.1046, §27.50(c)	Limit≤13dB	PASS
Modulation Characteristics	§2.1047	Digitalmodulation	N/A
Bandwidth	§2.1049	OBW: Nolimit. EBW: Nolimit.	PASS
BandEdges Compliance	§2.1051, §27.53(g)	≤ -13dBm/1%*EBW,in1 MHz bands immediately outside and adjacent to The frequency block.	PASS
Spurious Emission at Antenna Terminals	§2.1051, §27.53(g)	≤ -13dBm/100KHz, from 9kHz to10 th harmonics but outside authorized Operating frequency ranges.	PASS
Frequency Stability	§2.1055, §27.54	Within authorized bands of operation/frequency block.	PASS
Radiatedspurious emission	§2.1053, §27.53(g)	≤ -13dBm/100KHz.	PASS

NOTE 1:For the verdict, the "N/A"denotes "not applicable",the "N/T"de notes "not tested".

3.5 Equipments Used during the Test

Item	Equipment	Manufacturer	Model No.	Serial No.	Cal Date	Due Date
1	Power Meter	R&S	NRVS	100444	2019-06-11	2020-06-10
2	Power Sensor	R&S	NRV-Z81	100458	2019-06-11	2020-06-10
3	Power Sensor	R&S	NRV-Z32	10057	2019-06-11	2020-06-10
4	LTE Test Software	Tonscend	JS1120-1	N/A	N/A	N/A
5	RF Control Unit	Tonscend	JS0806	158060009	2019-06-11	2020-06-10
6	MXA Signal Analyzer	Agilent	N9020A	MY51250905	2018-11-15	2019-11-14
7	WIDEBAND RADIO COMMUNICATION TESTER	R&S	CMW 500	103818	2019-06-11	2020-06-10
8	DC Power Supply	Agilent	E3642A	N/A	2018-11-15	2019-11-14
9	Temperature & Humidity Chamber	GUANGZHOU GOGNWEN	GDS-100	70932	2019-10-09	2020-10-08
10	EMI Test Software	AUDIX	E3	N/A	N/A	N/A
11	3m Semi Anechoic Chamber	SIDT FRANKONIA	SAC-3M	03CH03-HY	2019-06-12	2020-06-11
12	Positioning Controller	MF	MF-7082	N/A	2019-06-12	2020-06-11
13	Active Loop Antenna	SCHWARZBEC K	FMZB 1519B	00005	2019-07-25	2020-07-24
14	By-log Antenna	SCHWARZBEC K	VULB9163	9163-470	2019-07-25	2020-07-24
15	Horn Antenna	SCHWARZBEC K	BBHA 9120D	9120D-1925	2019-07-01	2020-06-30
16	Broadband Horn Antenna	SCHWARZBEC K	BBHA 9170	791	2019-09-19	2020-09-18
17	Broadband Preamplifier	SCHWARZBEC K	BBV 9719	9719-025	2019-09-19	2020-09-18
18	EMI Test Receiver	R&S	ESR 7	101181	2019-06-12	2020-06-11
19	RS SPECTRUM ANALYZER	R&S	FSP40	100503	2018-11-15	2019-11-14
20	AMPLIFIER	QuieTek	QTK	CHM/0809065	2018-11-15	2019-11-14
21	RF Cable-R03m	Jye Bao	RG142	CB021	2019-06-12	2020-06-11
22	RF Cable-HIGH	SUHNER	SUCOFLE X 106	03CH03-HY	2019-06-12	2020-06-11
23	6dB Attenuator	/	100W/6dB	1172040	2019-06-11	2020-06-10
24	3dB Attenuator	/	2N-3dB	/	2019-06-11	2020-06-10
25	Temperature & Humidity Chamber	GUANGZHOU GOGNWEN	GDS-100	70932	2019-10-09	2020-10-08

Note: All equipment is calibrated through CHINA CEPREI LABORATORY and GUANGZHOU LISAI CALIBRATION AND TEST CO., LTD.

3.6 Measurement uncertainty

The data and results referenced in this document are true and accurate. The reader is cautioned that there may be errors within the calibration limits of the equipment and facilities. The measurement uncertainty was calculated for all measurements listed in this test report acc. to ETSI TR 100 028 "Electromagnetic compatibility and Radio spectrum Matters (ERM); Uncertainties in the measurement of mobile radio equipment characteristics" and is documented in the Shenzhen LCS Compliance Testing Laboratory Ltd. quality system acc. to DIN EN ISO/IEC 17025. Furthermore, component and process variability of devices similar to that tested may result in additional deviation. The manufacturer has the sole responsibility of continued compliance of the device.

Hereafter the best measurement capability for Shenzhen LCS Compliance Testing Laboratory Ltd. is reported:

Test	Range	Measurement Uncertainty	Notes
Radiated Emission	30~1000MHz	3.10 dB	(1)
Radiated Emission	1~18GHz	3.80 dB	(1)
Radiated Emission	18-40GHz	3.90 dB	(1)
Conducted Disturbance	0.15~30MHz	1.63 dB	(1)
Conducted Power	9KHz~18GHz	0.61 dB	(1)
Spurious RF Conducted Emission	9KHz~40GHz	1.22 dB	(1)
Band Edge Compliance of RF Emission	9KHz~40GHz	1.22 dB	(1)
Occupied Bandwidth	9KHz~40GHz	-	(1)

(1) This uncertainty represents an expanded uncertainty expressed at approximately the 95% confidence level using a coverage factor of $k=1.96$.

4 TEST CONDITIONS AND RESULTS

4.1 Output Power

TEST APPLICABLE

During the process of testing, the EUT was controlled via R&S Digital Radio Communication tester (CMW500) to ensure max power transmission and proper modulation. This result contains output power and EIRP measurements for the EUT. In all cases, output power is within the specified limits.

4.1.1. Conducted Output Power

TEST CONFIGURATION

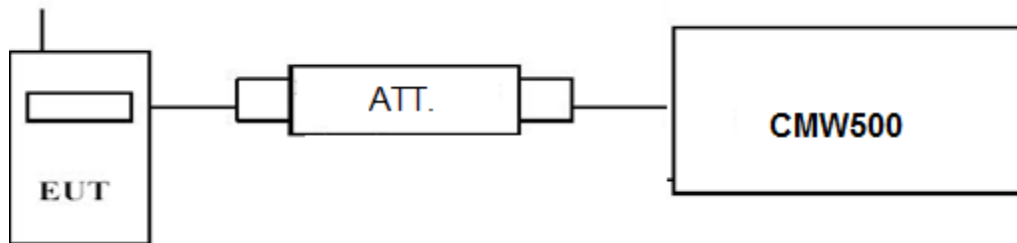

TEST PROCEDURE

Conducted Power Measurement:

- Place the EUT on a bench and set it in transmitting mode.
- Connect a low loss RF cable from the antenna port to a CMW500 by an Att.
- EUT Communicate with CMW500 then selects a channel for testing.
- Add a correction factor to the display CMW500, and then test.

TEST RESULTS

Remark:

- We were tested all RB Configuration refer 3GPP TS136 521 for each Channel Bandwidth of LTE FDD Band 2, LTE FDD Band 4 and LTE FDD Band 12; recorded worst case for each Channel Bandwidth of LTE FDD Band 2, LTE FDD Band 4 and LTE FDD Band 12
- For E-UTRA Band 2, please refer to Appendix A: Section A.1
- For E-UTRA Band 4, please refer to Appendix B: Section B.1
- For E-UTRA Band 12, please refer to Appendix C Section C.1

4.1.2. Radiated Output Power

LIMIT

This is the test for the maximum radiated power from the EUT.

Per §22.913(2) Extend coverage on a secondary basis into cellular unserved areas, as those areas are defined in §22.949, the ERP of base transmitters and cellular repeaters of such systems must not exceed 1000 Watts. The ERP of mobile transmitters and auxiliary test transmitters must not exceed 7 Watts.

Rule Part 24.232(c) specifies, "Mobile/portable stations are limited to 2 watts e.i.r.p. Peak power" and 24.232(e) specifies that "Peak transmit power must be measured over any interval of continuous transmission using instrumentation calibrated in terms of an rms-equivalent voltage."

Per Part 27.50(d) (4) specifies, Fixed, mobile, and portable (hand-held) stations operating in the 1710-1755MHz band are limited to 1W EIRP. Fixed stations operating in this band are limited to a maximum antenna height of 10 meters above ground. Mobile and portable stations operating in this band must employ a means for limiting power to the minimum necessary for successful communications.

Per Part 27.50(c) (10) specifies, Portable stations (hand-held devices) in the 600 MHz uplink band and the 698-746 MHz band, and fixed and mobile stations in the 600 MHz uplink band are limited to 3 watts ERP.

Per Part 27.50(h) (2) specifies Mobile and other user stations. Mobile stations are limited to 2.0 watts EIRP. All user stations are limited to 2.0 watts transmitter output power.

TEST CONFIGURATION

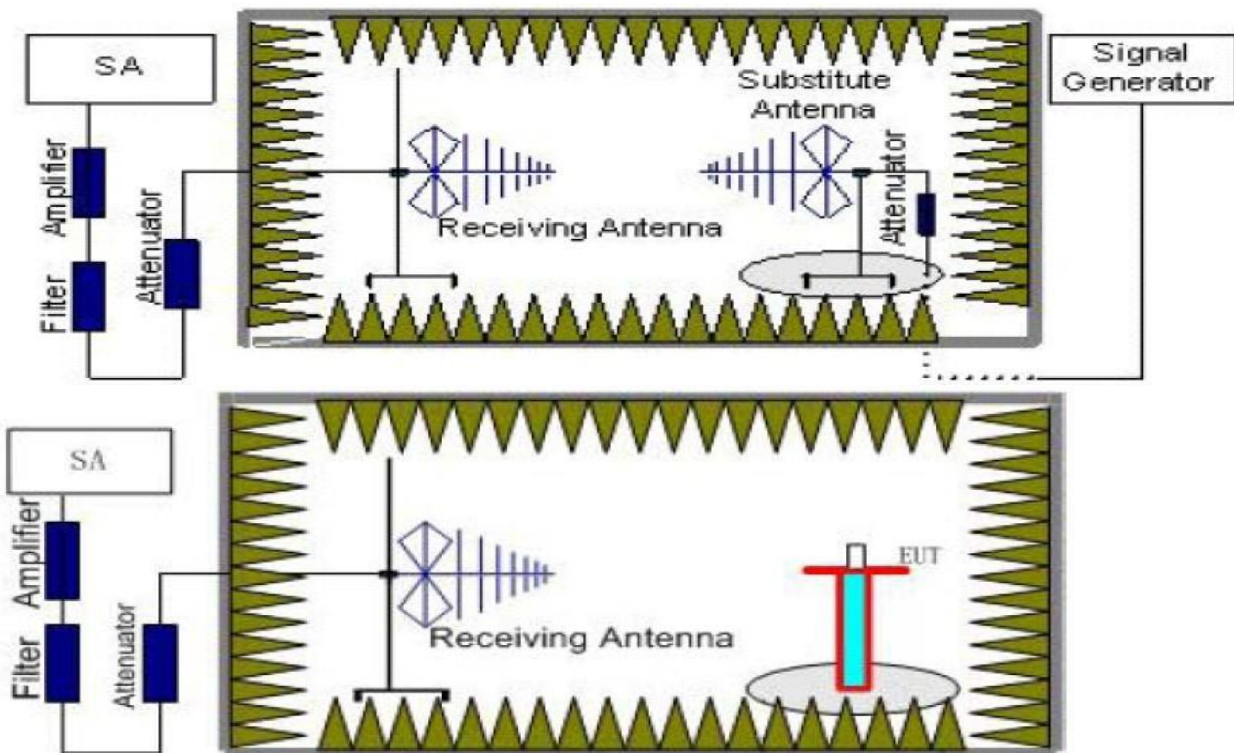

TEST PROCEDURE

1. EUT was placed on a 1.50 meter high non-conductive stand at a 3 meter test distance from the receive antenna. A receiving antenna was placed on the antenna mast 3 meters from the EUT for emission measurements. The height of receiving antenna is 1.50m. Detected emissions were maximized at each frequency by rotating the EUT through 360° and adjusting the receiving antenna polarization. The radiated emission measurements of all transmit frequencies in three channels (High, Middle, Low) were measured with peak detector.
2. A log-periodic antenna or double-ridged waveguide horn antenna shall be substituted in place of the EUT. The log-periodic antenna will be driven by a signal generator and the level will be adjusted till the same power value on the spectrum analyzer or receiver. The level of the spurious emissions can be calculated through the level of the signal generator, cable loss, the gain of the substitution antenna and the reading of the spectrum analyzer or receiver.

3. The EUT is then put into continuously transmitting mode at its maximum power level during the test. Set Test Receiver or Spectrum RBW=1MHz, VBW=3MHz, And the maximum value of the receiver should be recorded as (P_r).
4. The EUT shall be replaced by a substitution antenna. In the chamber, an substitution antenna for the frequency band of interest is placed at the reference point of the chamber. An RF Signal source for the frequency band of interest is connected to the substitution antenna with a cable that has been constructed to not interfere with the radiation pattern of the antenna. A power (P_{Mea}) is applied to the input of the substitution antenna, and adjust the level of the signal generator output until the value of the receiver reach the previously recorded (P_r). The power of signal source (P_{Mea}) is recorded. The test should be performed by rotating the test item and adjusting the receiving antenna polarization.
5. A amplifier should be connected to the Signal Source output port. And the cable should be connect between the Amplifier and the Substitution Antenna. The cable loss (P_{cl}), the Substitution Antenna Gain (G_a) and the Amplifier Gain (P_{Ag}) should be recorded after test.
The measurement results are obtained as described below:
 $Power(EIRP) = P_{Mea} + P_{Ag} - P_{cl} + G_a$
6. This value is EIRP since the measurement is calibrated using an antenna of known gain (2.15 dBi) and known input power.
7. ERP can be calculated from EIRP by subtracting the gain of the dipole, $ERP = EIRP - 2.15dBi$.

TEST RESULTS

Radiated Measurement:

Remark:

1. We were tested all RB Configuration refer 3GPP TS136 521 for each Channel Bandwidth of LTE FDD Band 2, LTE FDD Band 4 and LTE FDD Band 12; recorded worst case for each Channel Bandwidth of LTE FDD Band 2, LTE FDD Band 4 and LTE FDD Band 12.
2. $EIRP = P_{Mea}(dBm) - P_{cl}(dB) + P_{Ag}(dB) + G_a(dBi)$
3. $ERP = EIRP - 2.15dBi$ as EIRP by subtracting the gain of the dipole.
4. Margin = Emission Level - Limit
5. We test the H direction and V direction recorded worst case

LTE FDD Band 2_ Channel Bandwidth 1.4MHz_ QPSK

Frequency (MHz)	P_{Mea} (dBm)	P_{cl} (dB)	G_a Antenna Gain(dB)	P_{Ag} (dB)	Burst Average EIRP (dBm)	Limit (dBm)	Margin (dB)	Polarization
1850.7	-17.37	4.03	8.38	35.51	22.49	33.01	-10.52	V
1880.0	-18.55	4.08	8.33	35.56	21.26	33.01	-11.75	V
1909.3	-18.97	4.14	8.26	35.63	20.78	33.01	-12.23	V

LTE FDD Band 2_ Channel Bandwidth 3MHz_ QPSK

Frequency (MHz)	P_{Mea} (dBm)	P_{cl} (dB)	G_a Antenna Gain(dB)	P_{Ag} (dB)	Burst Average EIRP (dBm)	Limit (dBm)	Margin (dB)	Polarization
1851.5	-17.46	4.03	8.38	35.51	22.40	33.01	-10.61	V
1880.0	-18.63	4.08	8.33	35.56	21.18	33.01	-11.83	V
1908.5	-18.87	4.14	8.26	35.63	20.88	33.01	-12.13	V

LTE FDD Band 2_ Channel Bandwidth 5MHz_ QPSK

Frequency (MHz)	P_{Mea} (dBm)	P_{cl} (dB)	G_a Antenna Gain(dB)	P_{Ag} (dB)	Burst Average EIRP (dBm)	Limit (dBm)	Margin (dB)	Polarization
1852.5	-17.48	4.03	8.38	35.51	22.38	33.01	-10.63	V
1880.0	-18.78	4.08	8.33	35.56	21.03	33.01	-11.98	V
1907.5	-18.92	4.14	8.26	35.63	20.83	33.01	-12.18	V

LTE FDD Band 2_Channel Bandwidth 10MHz_QPSK

Frequency (MHz)	P _{Mea} (dBm)	P _{cl} (dB)	G _a Antenna Gain(dB)	P _{Ag} (dB)	Burst Average EIRP (dBm)	Limit (dBm)	Margin (dB)	Polarization
1855.0	-17.55	4.03	8.38	35.51	22.31	33.01	-10.70	V
1880.0	-18.51	4.08	8.33	35.56	21.30	33.01	-11.71	V
1905.0	-19.03	4.14	8.26	35.63	20.72	33.01	-12.29	V

LTE FDD Band 2_Channel Bandwidth 15MHz_QPSK

Frequency (MHz)	P _{Mea} (dBm)	P _{cl} (dB)	G _a Antenna Gain(dB)	P _{Ag} (dB)	Burst Average EIRP (dBm)	Limit (dBm)	Margin (dB)	Polarization
1857.5	-17.51	4.03	8.38	35.51	22.35	33.01	-10.66	V
1880.0	-18.80	4.08	8.33	35.56	21.01	33.01	-12.00	V
1902.5	-19.14	4.14	8.26	35.63	20.61	33.01	-12.40	V

LTE FDD Band 2_Channel Bandwidth 20MHz_QPSK

Frequency (MHz)	P _{Mea} (dBm)	P _{cl} (dB)	G _a Antenna Gain(dB)	P _{Ag} (dB)	Burst Average EIRP (dBm)	Limit (dBm)	Margin (dB)	Polarization
1860.0	-17.58	4.03	8.38	35.51	22.28	33.01	-10.73	V
1880.0	-18.49	4.08	8.33	35.56	21.32	33.01	-11.69	V
1900.0	-19.21	4.14	8.26	35.63	20.54	33.01	-12.47	V

LTE FDD Band 2_Channel Bandwidth 1.4MHz_16QAM

Frequency (MHz)	P _{Mea} (dBm)	P _{cl} (dB)	G _a Antenna Gain(dB)	P _{Ag} (dB)	Burst Average EIRP (dBm)	Limit (dBm)	Margin (dB)	Polarization
1850.7	-17.37	4.03	8.38	35.51	22.49	33.01	-10.52	V
1880.0	-18.75	4.08	8.33	35.56	21.06	33.01	-11.95	V
1909.3	-19.13	4.14	8.26	35.63	20.62	33.01	-12.39	V

LTE FDD Band 2_Channel Bandwidth 3MHz_16QAM

Frequency (MHz)	P _{Mea} (dBm)	P _{cl} (dB)	G _a Antenna Gain(dB)	P _{Ag} (dB)	Burst Average EIRP (dBm)	Limit (dBm)	Margin (dB)	Polarization
1851.5	-17.46	4.03	8.38	35.51	22.40	33.01	-10.61	V
1880.0	-18.66	4.08	8.33	35.56	21.15	33.01	-11.86	V
1908.5	-19.23	4.14	8.26	35.63	20.52	33.01	-12.49	V

LTE FDD Band 2_Channel Bandwidth 5MHz_16QAM

Frequency (MHz)	P _{Mea} (dBm)	P _{cl} (dB)	G _a Antenna Gain(dB)	P _{Ag} (dB)	Burst Average EIRP (dBm)	Limit (dBm)	Margin (dB)	Polarization
1852.5	-17.67	4.03	8.38	35.51	22.19	33.01	-10.82	V
1880.0	-18.84	4.08	8.33	35.56	20.97	33.01	-12.04	V
1907.5	-18.89	4.14	8.26	35.63	20.86	33.01	-12.15	V

LTE FDD Band 2_Channel Bandwidth 10MHz_16QAM

Frequency (MHz)	P _{Mea} (dBm)	P _{cl} (dB)	G _a Antenna Gain(dB)	P _{Ag} (dB)	Burst Average EIRP (dBm)	Limit (dBm)	Margin (dB)	Polarization
1855.0	-17.47	4.03	8.38	35.51	22.39	33.01	-10.62	V
1880.0	-18.61	4.08	8.33	35.56	21.20	33.01	-11.81	V
1905.0	-19.23	4.14	8.26	35.63	20.52	33.01	-12.49	V

LTE FDD Band 2_Channel Bandwidth 15MHz_16QAM

Frequency (MHz)	P _{Mea} (dBm)	P _{cl} (dB)	G _a Antenna Gain(dB)	P _{Ag} (dB)	Burst Average EIRP (dBm)	Limit (dBm)	Margin (dB)	Polarization
1857.5	-17.70	4.03	8.38	35.51	22.16	33.01	-10.85	V
1880.0	-18.72	4.08	8.33	35.56	21.09	33.01	-11.92	V
1902.5	-18.88	4.14	8.26	35.63	20.87	33.01	-12.14	V

LTE FDD Band 2_Channel Bandwidth 20MHz_16QAM

Frequency (MHz)	P _{Mea} (dBm)	P _{cl} (dB)	G _a Antenna Gain(dB)	P _{Ag} (dB)	Burst Average EIRP (dBm)	Limit (dBm)	Margin (dB)	Polarization
1860.0	-17.63	4.03	8.38	35.51	22.23	33.01	-10.78	V
1880.0	-18.56	4.08	8.33	35.56	21.25	33.01	-11.76	V
1900.0	-19.04	4.14	8.26	35.63	20.71	33.01	-12.30	V

LTE FDD Band 4_Channel Bandwidth 1.4MHz_QPSK

Frequency (MHz)	P _{Mea} (dBm)	P _{cl} (dB)	G _a Antenna Gain(dB)	P _{Ag} (dB)	Burst Average EIRP (dBm)	Limit (dBm)	Margin (dB)	Polarization
1710.7	-17.41	3.93	9.05	34.96	22.67	30.00	-7.33	V
1732.5	-18.53	3.93	8.89	35.01	21.44	30.00	-8.56	V
1754.3	-18.88	3.94	8.76	35.08	21.02	30.00	-8.98	V

LTE FDD Band 4_Channel Bandwidth 3MHz_QPSK

Frequency (MHz)	P _{Mea} (dBm)	P _{cl} (dB)	G _a Antenna Gain(dB)	P _{Ag} (dB)	Burst Average EIRP (dBm)	Limit (dBm)	Margin (dB)	Polarization
1711.5	-17.61	3.93	9.05	34.96	22.47	30.00	-7.53	V
1732.5	-18.79	3.93	8.89	35.01	21.18	30.00	-8.82	V
1753.5	-18.91	3.94	8.76	35.08	20.99	30.00	-9.01	V

LTE FDD Band 4_Channel Bandwidth 5MHz_QPSK

Frequency (MHz)	P _{Mea} (dBm)	P _{cl} (dB)	G _a Antenna Gain(dB)	P _{Ag} (dB)	Burst Average EIRP (dBm)	Limit (dBm)	Margin (dB)	Polarization
1712.5	-17.68	3.93	9.05	34.96	22.40	30.00	-7.60	V
1732.5	-18.48	3.93	8.89	35.01	21.49	30.00	-8.51	V
1752.5	-18.93	3.94	8.76	35.08	20.97	30.00	-9.03	V

LTE FDD Band 4_Channel Bandwidth 10MHz_QPSK

Frequency (MHz)	P _{Mea} (dBm)	P _{cl} (dB)	G _a Antenna Gain(dB)	P _{Ag} (dB)	Burst Average EIRP (dBm)	Limit (dBm)	Margin (dB)	Polarization
1715.0	-17.41	3.93	9.05	34.96	22.67	30.00	-7.33	V
1732.5	-18.85	3.93	8.89	35.01	21.12	30.00	-8.88	V
1750.0	-19.10	3.94	8.76	35.08	20.80	30.00	-9.20	V

LTE FDD Band 4_Channel Bandwidth 15MHz_QPSK

Frequency (MHz)	P _{Mea} (dBm)	P _{cl} (dB)	G _a Antenna Gain(dB)	P _{Ag} (dB)	Burst Average EIRP (dBm)	Limit (dBm)	Margin (dB)	Polarization
1717.5	-17.62	3.93	9.05	34.96	22.46	30.00	-7.54	V
1732.5	-18.86	3.93	8.89	35.01	21.11	30.00	-8.89	V
1747.5	-19.16	3.94	8.76	35.08	20.74	30.00	-9.26	V

LTE FDD Band 4_Channel Bandwidth 20MHz_QPSK

Frequency (MHz)	P _{Mea} (dBm)	P _{cl} (dB)	G _a Antenna Gain(dB)	P _{Ag} (dB)	Burst Average EIRP (dBm)	Limit (dBm)	Margin (dB)	Polarization
1720.0	-17.75	3.93	9.05	34.96	22.33	30.00	-7.67	V
1732.5	-18.85	3.93	8.89	35.01	21.12	30.00	-8.88	V
1745.0	-18.87	3.94	8.76	35.08	21.03	30.00	-8.97	V

LTE FDD Band 4_Channel Bandwidth 1.4MHz_16QAM

Frequency (MHz)	P _{Mea} (dBm)	P _{cl} (dB)	G _a Antenna Gain(dB)	P _{Ag} (dB)	Burst Average EIRP (dBm)	Limit (dBm)	Margin (dB)	Polarization
1710.7	-17.41	3.93	9.05	34.96	22.67	30.00	-7.33	V
1732.5	-18.77	3.93	8.89	35.01	21.20	30.00	-8.80	V
1754.3	-19.03	3.94	8.76	35.08	20.87	30.00	-9.13	V

LTE FDD Band 4_Channel Bandwidth 3MHz_16QAM

Frequency (MHz)	P _{Mea} (dBm)	P _{cl} (dB)	G _a Antenna Gain(dB)	P _{Ag} (dB)	Burst Average EIRP (dBm)	Limit (dBm)	Margin (dB)	Polarization
1711.5	-17.72	3.93	9.05	34.96	22.36	30.00	-7.64	V
1732.5	-18.61	3.93	8.89	35.01	21.36	30.00	-8.64	V
1753.5	-19.06	3.94	8.76	35.08	20.84	30.00	-9.16	V

LTE FDD Band 4_Channel Bandwidth 5MHz_16QAM

Frequency (MHz)	P _{Mea} (dBm)	P _{cl} (dB)	G _a Antenna Gain(dB)	P _{Ag} (dB)	Burst Average EIRP (dBm)	Limit (dBm)	Margin (dB)	Polarization
1712.5	-17.64	3.93	9.05	34.96	22.44	30.00	-7.56	V
1732.5	-18.61	3.93	8.89	35.01	21.36	30.00	-8.64	V
1752.5	-19.18	3.94	8.76	35.08	20.72	30.00	-9.28	V

LTE FDD Band 4_Channel Bandwidth 10MHz_16QAM

Frequency (MHz)	P _{Mea} (dBm)	P _{cl} (dB)	G _a Antenna Gain(dB)	P _{Ag} (dB)	Burst Average EIRP (dBm)	Limit (dBm)	Margin (dB)	Polarization
1715.0	-17.71	3.93	9.05	34.96	22.37	30.00	-7.63	V
1732.5	-18.84	3.93	8.89	35.01	21.13	30.00	-8.87	V
1750.0	-19.08	3.94	8.76	35.08	20.82	30.00	-9.18	V

LTE FDD Band 4_Channel Bandwidth 15MHz_16QAM

Frequency (MHz)	P _{Mea} (dBm)	P _{cl} (dB)	G _a Antenna Gain(dB)	P _{Ag} (dB)	Burst Average EIRP (dBm)	Limit (dBm)	Margin (dB)	Polarization
1717.5	-17.51	3.93	9.05	34.96	22.57	30.00	-7.43	V
1732.5	-18.48	3.93	8.89	35.01	21.49	30.00	-8.51	V
1747.5	-19.02	3.94	8.76	35.08	20.88	30.00	-9.12	V

LTE FDD Band 4_Channel Bandwidth 20MHz_16QAM

Frequency (MHz)	P _{Mea} (dBm)	P _{cl} (dB)	G _a Antenna Gain(dB)	P _{Ag} (dB)	Burst Average EIRP (dBm)	Limit (dBm)	Margin (dB)	Polarization
1720.0	-17.44	3.93	9.05	34.96	22.64	30.00	-7.36	V
1732.5	-18.49	3.93	8.89	35.01	21.48	30.00	-8.52	V
1745.0	-19.03	3.94	8.76	35.08	20.87	30.00	-9.13	V

LTE FDD Band 12_Channel Bandwidth 1.4MHz_QPSK

Frequency (MHz)	P _{Mea} (dBm)	P _{cl} (dB)	G _a Antenna Gain (dB)	P _{Ag} (dB)	Correction (dB)	Burst Average ERP (dBm)	Limit (dBm)	Margin (dB)	Polarization
699.70	-19.13	3.01	8.29	2.15	33.52	20.61	34.77	-14.16	V
707.50	-20.53	3.02	8.29	2.15	33.52	19.06	34.77	-15.71	V
715.30	-19.95	3.06	8.29	2.15	33.52	19.69	34.77	-15.08	V

LTE FDD Band 12_Channel Bandwidth 3MHz_QPSK

Frequency (MHz)	P _{Mea} (dBm)	P _{cl} (dB)	G _a Antenna Gain (dB)	P _{Ag} (dB)	Correction (dB)	Burst Average ERP (dBm)	Limit (dBm)	Margin (dB)	Polarization
700.50	-18.84	3.01	8.29	2.15	33.52	20.90	34.77	-13.87	V
707.50	-20.65	3.02	8.29	2.15	33.52	18.94	34.77	-15.83	V
714.50	-20.04	3.06	8.29	2.15	33.52	19.60	34.77	-15.17	V

LTE FDD Band 12_Channel Bandwidth 5MHz_QPSK

Frequency (MHz)	P _{Mea} (dBm)	P _{cl} (dB)	G _a Antenna Gain (dB)	P _{Ag} (dB)	Correction (dB)	Burst Average ERP (dBm)	Limit (dBm)	Margin (dB)	Polarization
701.50	-18.98	3.01	8.29	2.15	33.52	20.76	34.77	-14.01	V
707.50	-20.80	3.02	8.29	2.15	33.52	18.79	34.77	-15.98	V
713.50	-19.82	3.06	8.29	2.15	33.52	19.82	34.77	-14.95	V

LTE FDD Band 12_Channel Bandwidth 10MHz_QPSK

Frequency (MHz)	P _{Mea} (dBm)	P _{cl} (dB)	G _a Antenna Gain (dB)	P _{Ag} (dB)	Correction (dB)	Burst Avergae ERP (dBm)	Limit (dBm)	Margin (dB)	Polarization
704.00	-18.94	3.01	8.29	2.15	33.52	20.80	34.77	-13.97	V
707.50	-20.52	3.02	8.29	2.15	33.52	19.07	34.77	-15.70	V
711.00	-19.97	3.06	8.29	2.15	33.52	19.67	34.77	-15.10	V

LTE FDD Band 12_Channel Bandwidth 1.4MHz_16QAM

Frequency (MHz)	P _{Mea} (dBm)	P _{cl} (dB)	G _a Antenna Gain (dB)	P _{Ag} (dB)	Correction (dB)	Burst Avergae ERP (dBm)	Limit (dBm)	Margin (dB)	Polarization
699.70	-19.07	3.01	8.29	2.15	33.52	20.67	34.77	-14.10	V
707.50	-20.60	3.02	8.29	2.15	33.52	18.99	34.77	-15.78	V
715.30	-20.08	3.06	8.29	2.15	33.52	19.56	34.77	-15.21	V

LTE FDD Band 12_Channel Bandwidth 3MHz_16QAM

Frequency (MHz)	P _{Mea} (dBm)	P _{cl} (dB)	G _a Antenna Gain (dB)	P _{Ag} (dB)	Correction (dB)	Burst Avergae ERP (dBm)	Limit (dBm)	Margin (dB)	Polarization
700.50	-19.02	3.01	8.29	2.15	33.52	20.72	34.77	-14.05	V
707.50	-20.74	3.02	8.29	2.15	33.52	18.85	34.77	-15.92	V
714.50	-19.92	3.06	8.29	2.15	33.52	19.72	34.77	-15.05	V

LTE FDD Band 12_Channel Bandwidth 5MHz_16QAM

Frequency (MHz)	P _{Mea} (dBm)	P _{cl} (dB)	G _a Antenna Gain (dB)	P _{Ag} (dB)	Correction (dB)	Burst Avergae ERP (dBm)	Limit (dBm)	Margin (dB)	Polarization
701.50	-19.07	3.01	8.29	2.15	33.52	20.67	34.77	-14.10	V
707.50	-20.79	3.02	8.29	2.15	33.52	18.80	34.77	-15.97	V
713.50	-19.95	3.06	8.29	2.15	33.52	19.69	34.77	-15.08	V

LTE FDD Band 12_Channel Bandwidth 10MHz_16QAM

Frequency (MHz)	P _{Mea} (dBm)	P _{cl} (dB)	G _a Antenna Gain (dB)	P _{Ag} (dB)	Correction (dB)	Burst Avergae ERP (dBm)	Limit (dBm)	Margin (dB)	Polarization
704.00	-19.20	3.01	8.29	2.15	33.52	20.54	34.77	-14.23	V
707.50	-20.70	3.02	8.29	2.15	33.52	18.89	34.77	-15.88	V
711.00	-20.03	3.06	8.29	2.15	33.52	19.61	34.77	-15.16	V

4.2 Peak-to-Average Ratio (PAR)

LIMIT

The Peak-to-Average Ratio (PAR) of the transmission may not exceed 13 dB.

TEST CONFIGURATION

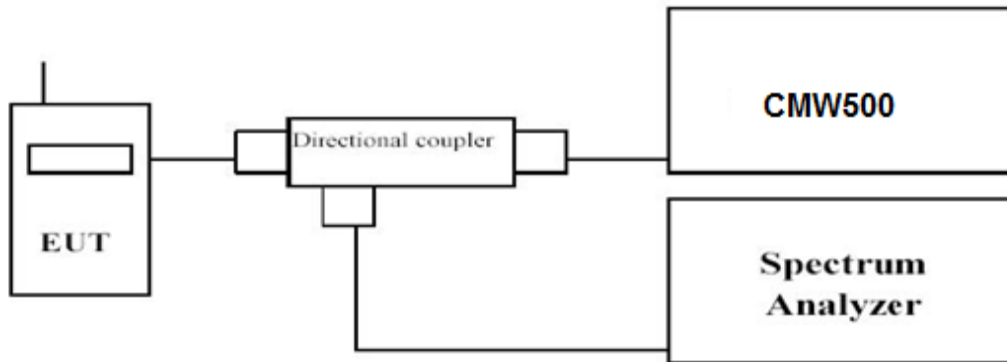

TEST PROCEDURE

1. Refer to instrument's analyzer instruction manual for details on how to use the power statistics/CCDF function;
2. Set resolution/measurement bandwidth \geq signal's occupied bandwidth;
3. Set the number of counts to a value that stabilizes the measured CCDF curve;
4. Set the measurement interval as follows:
 - 1). for continuous transmissions, set to 1 ms,
 - 2). for burst transmissions, employ an external trigger that is synchronized with the EUT burst timing sequence, or use the internal burst trigger with a trigger level that allows the burst to stabilize and set the measurement interval to a time that is less than or equal to the burst duration.
5. Record the maximum PAPR level associated with a probability of 0.1%.

TEST RESULTS

Remark:

1. We were tested all RB Configuration refer 3GPP TS136 521 for each Channel Bandwidth of LTE FDD Band 2, LTE FDD Band 4 and LTE FDD Band 12; recorded worst case for each Channel Bandwidth of LTE FDD Band 2, LTE FDD Band 4 and LTE FDD Band 12
2. For E-UTRA Band 2, please refer to Appendix A: Section A.1
3. For E-UTRA Band 4, please refer to Appendix B: Section B.1
4. For E-UTRA Band 12, please refer to Appendix C Section C.1

4.3 Occupied Bandwidth and Emission Bandwidth

LIMIT

N/A

TEST CONFIGURATION

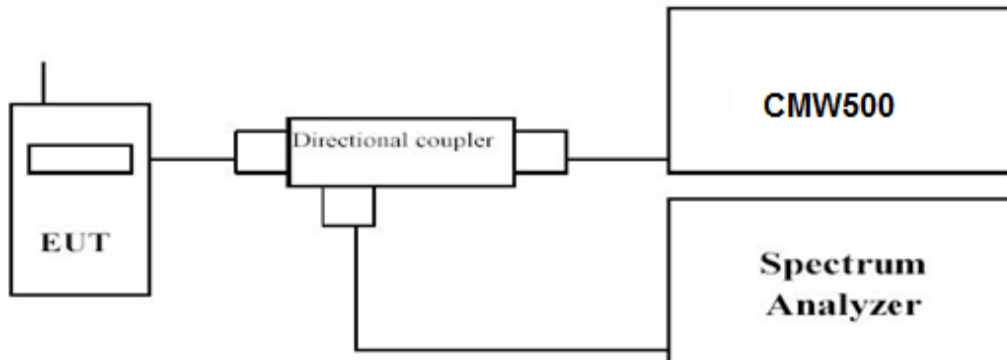

TEST PROCEDURE

The transmitter output was connected to a calibrated coaxial cable and coupler, the other end of which was connected to a spectrum analyzer. The occupied bandwidth was measured with the spectrum analyzer at low, middle and high channel in each band. The -26dBc Emission bandwidth was also measured and recorded. Set RBW was set to about 1% of emission BW, VBW \geq 3 times RBW. -26dBc display line was placed on the screen (or 99% bandwidth), the occupied bandwidth is the delta frequency between the two points where the display line intersects the signal trace.

TEST RESULTS

Remark:

1. We were tested all RB Configuration refer 3GPP TS136 521 for each Channel Bandwidth of LTE FDD Band 2, LTE FDD Band 4 and LTE FDD Band 12; recorded worst case for each Channel Bandwidth of LTE FDD Band 2, LTE FDD Band 4 and LTE FDD Band 12.
2. For E-UTRA Band 2, please refer to Appendix A: Section A.1
3. For E-UTRA Band 4, please refer to Appendix B: Section B.1
4. For E-UTRA Band 12, please refer to Appendix C Section C.1

4.4 Band Edge compliance

LIMIT

For LTE FDD Band 2: Per FCC §24.238 the power of any emission outside of the authorized operating frequency ranges must be attenuated below the transmitting power (P) by a factor of at least $43 + 10\log(P)$ dB.

For LTE FDD Band 4: Per §27.53(h): For operations in the 1710–1755 MHz and 2110–2155 MHz bands, the power of any emission outside a licensee's frequency block shall be attenuated below the transmitter power (P) by at least $43 + 10\log(P)$ dB.

For LTE FDD Band 12: Per §27.53 (g): For operations in the 698–746 MHz band, the power of any emission outside a licensee's frequency band(s) of operation shall be attenuated below the transmitter power (P) within the licensed band(s) of operation, measured in watts, by at least $43 + 10\log(P)$ dB.

TEST CONFIGURATION

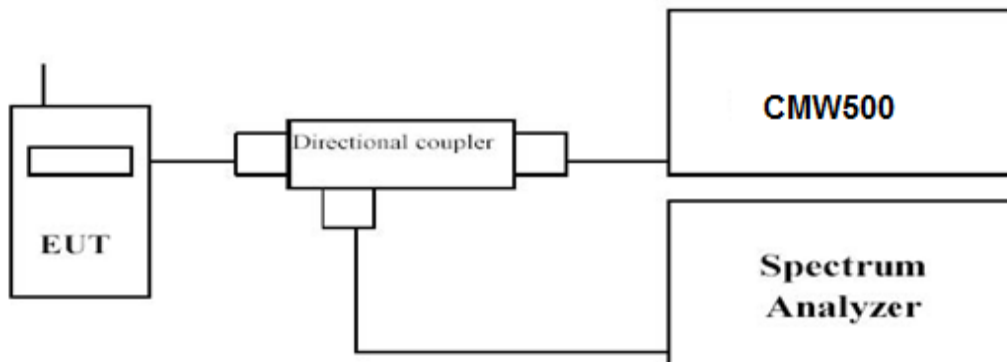

TEST PROCEDURE

1. The transmitter output port was connected to base station.
2. The RF output of EUT was connected to the power meter by RF cable and attenuator, the path loss was compensated to the results for each measurement.
3. Set EUT at maximum power through base station.
4. Select lowest and highest channels for each band and different modulation.
5. Measure Band edge using RMS (Average) detector by spectrum

TEST RESULTS

Remark:

- 1. We were tested all RB Configuration refer 3GPP TS136 521 for each Channel Bandwidth of LTE FDD Band 2, LTE FDD Band 4 and LTE FDD Band 12; recorded worst case for each Channel Bandwidth of LTE FDD Band 2, LTE FDD Band 4 and LTE FDD Band 12.*
- 2. For E-UTRA Band 2, please refer to Appendix A: Section A.1*
- 3. For E-UTRA Band 4, please refer to Appendix B: Section B.1*
- 4. For E-UTRA Band 12, please refer to Appendix C Section C.1*

4.5 Spurious Emission on Antenna Port

LIMIT

For LTE FDD Band 2: Per FCC §24.238 the power of any emission outside of the authorized operating frequency ranges must be attenuated below the transmitting power (P) by a factor of at least $43 + 10\log(P)$ dB.

For LTE FDD Band 4: Per §27.53(h): For operations in the 1710–1755 MHz and 2110–2155 MHz bands, the power of any emission outside a licensee's frequency block shall be attenuated below the transmitter power (P) by at least $43 + 10\log(P)$ dB.

For LTE FDD Band 12: Per §27.53 (g): For operations in the 698–746 MHz band, the power of any emission outside a licensee's frequency band(s) of operation shall be attenuated below the transmitter power (P) within the licensed band(s) of operation, measured in watts, by at least $43 + 10\log(P)$ dB.

TEST CONFIGURATION

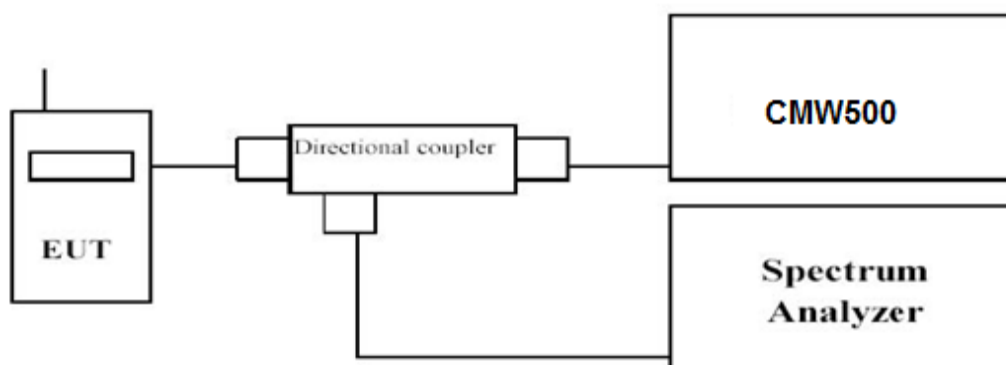

TEST PROCEDURE

The EUT was setup according to TIA-603-E

- Place the EUT on a bench and set it in transmitting mode.
- Connect a low loss RF cable from the antenna port to a spectrum analyzer and CMW500 by a Directional Couple.
- EUT Communicate with CMW500, then select a channel for testing.
- Add a correction factor to the display of spectrum, and then test.
- The resolution bandwidth of the spectrum analyzer was setsufficient scans were taken to show the out of band Emission if any up to 10th harmonic.
- Please refer to following tables for test antenna conducted emissions.

Working Frequency	Sub range (GHz)	RBW	VBW	Sweep time (s)
LTE FDD Band 2	0.000009~0.000015	1KHz	3KHz	Auto
	0.000015~0.03	10KHz	30KHz	Auto
	0.03~26	1 MHz	3 MHz	Auto
LTE FDD Band 4	0.000009~0.000015	1KHz	3KHz	Auto
	0.000015~0.03	10KHz	30KHz	Auto
	0.03~26	1 MHz	3 MHz	Auto
LTE FDD Band 12	0.000009~0.000015	1KHz	3KHz	Auto
	0.000015~0.03	10KHz	30KHz	Auto
	0.03~26	1 MHz	3 MHz	Auto

TEST RESULTS

Remark:

1. We were tested all RB Configuration refer 3GPP TS136 521 for each Channel Bandwidth of LTE FDD Band 2, LTE FDD Band 4 and LTE FDD Band 12; recorded worst case for each Channel Bandwidth of LTE FDD Band 2, LTE FDD Band 4 and LTE FDD Band 12.
2. For E-UTRA Band 2, please refer to Appendix A: Section A.1
3. For E-UTRA Band 4, please refer to Appendix B: Section B.1
4. For E-UTRA Band 12, please refer to Appendix C Section C.1

4.6 Radiated Spurious Emission

LIMIT

For LTE FDD Band 2: Per FCC §24.238 the power of any emission outside of the authorized operating frequency ranges must be attenuated below the transmitting power (P) by a factor of at least $43 + 10\log(P)$ dB.

For LTE FDD Band 4: Per §27.53(h): For operations in the 1710–1755 MHz and 2110–2155 MHz bands, the power of any emission outside a licensee's frequency block shall be attenuated below the transmitter power (P) by at least $43 + 10\log(P)$ dB.

For LTE FDD Band 12: Per §27.53 (g): For operations in the 698–746 MHz band, the power of any emission outside a licensee's frequency band(s) of operation shall be attenuated below the transmitter power (P) within the licensed band(s) of operation, measured in watts, by at least $43 + 10\log(P)$ dB.

TEST CONFIGURATION

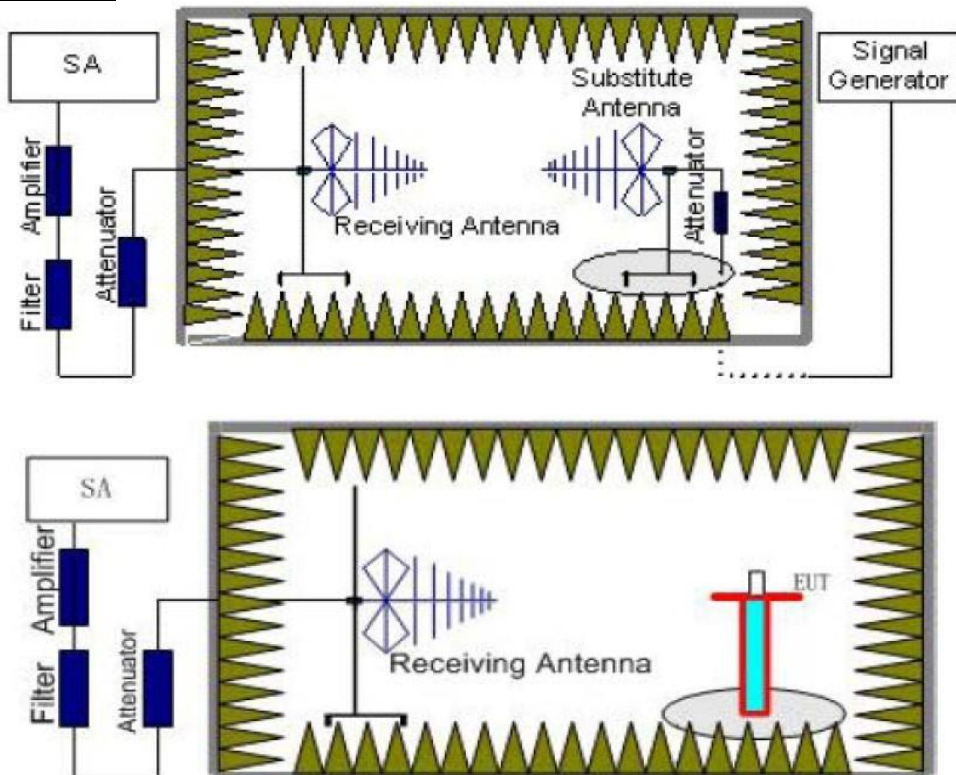

TEST PROCEDURE

1. EUT was placed on a 1.50 meter high non-conductive stand at a 3 meter test distance from the receive antenna. A receiving antenna was placed on the antenna mast 3 meters from the EUT for emission measurements. The height of receiving antenna is 1.50m. Detected emissions were maximized at each frequency by rotating the EUT through 360° and adjusting the receiving antenna polarization. The radiated emission measurements of all transmit frequencies in three channels (High, Middle, Low) were measured with peak detector.
2. A log-periodic antenna or double-ridged waveguide horn antenna shall be substituted in place of the EUT. The log-periodic antenna will be driven by a signal generator and the level will be adjusted till the same power value on the spectrum analyzer or receiver. The level of the spurious emissions can be calculated through the level of the signal generator, cable loss, the gain of the substitution antenna and the reading of the spectrum analyzer or receiver.
3. The EUT is then put into continuously transmitting mode at its maximum power level during the test. Set Test Receiver or Spectrum RBW=1MHz, VBW=3MHz, And the maximum value of the receiver should be recorded as (P_r).
4. The EUT shall be replaced by a substitution antenna. In the chamber, an substitution antenna for the frequency band of interest is placed at the reference point of the chamber. An RF Signal source for the frequency band of interest is connected to the substitution antenna with a cable that has been constructed to not interfere with the radiation pattern of the antenna. A power (P_{Mea}) is applied to the input of the substitution antenna, and adjust the level of the signal generator output until the value of the receiver reach the previously recorded (P_r). The power of signal source (P_{Mea}) is recorded. The test should be performed by rotating the test item and adjusting the receiving antenna polarization.
5. A amplifier should be connected to the Signal Source output port. And the cable should be connect between the Amplifier and the Substitution Antenna. The cable loss (P_{cl}), the Substitution Antenna Gain (G_a) and the Amplifier Gain (P_{Ag}) should be recorded after test.
The measurement results are obtained as described below:
 $Power(EIRP) = P_{Mea} + P_{Ag} - P_{cl} + G_a$
6. This value is EIRP since the measurement is calibrated using an antenna of known gain (2.15 dBi) and known input power.
7. ERP can be calculated from EIRP by subtracting the gain of the dipole, $ERP = EIRP - 2.15dBi$.
8. In order to make sure test results more clearly, we set frequency range and sweep time for difference frequency range as follows table:

Working Frequency	Subrange (GHz)	RBW	VBW	Sweep time (s)
LTE FDD Band 2	0.00009~0.15	1KHz	3KHz	30
	0.00015~0.03	10KHz	30KHz	10
	0.03~1	100KHz	300KHz	10
	1~2	1 MHz	3 MHz	2
	2~5	1 MHz	3 MHz	3
	5~8	1 MHz	3 MHz	3
	8~11	1 MHz	3 MHz	3
	11~14	1 MHz	3 MHz	3
	14~18	1 MHz	3 MHz	3
LTE FDD Band 4	18~20	1 MHz	3 MHz	2
	0.00009~0.15	1KHz	3KHz	30
	0.00015~0.03	10KHz	30KHz	10
	0.03~1	100KHz	300KHz	10
	1~2	1 MHz	3 MHz	2
	2~5	1 MHz	3 MHz	3
	5~8	1 MHz	3 MHz	3
	8~11	1 MHz	3 MHz	3
	11~14	1 MHz	3 MHz	3
LTE FDD Band 12	14~18	1 MHz	3 MHz	3
	0.00009~0.15	1KHz	3KHz	30
	0.00015~0.03	10KHz	30KHz	10
	0.03~1	100KHz	300KHz	10
	1~2	1 MHz	3 MHz	2
	2~5	1 MHz	3 MHz	3
5~8	1 MHz	3 MHz	3	

TEST LIMITS

According to 27.53(h) specify that the power of any emission outside of the authorized operating frequency ranges must be attenuated below the transmitting power (P) by a factor of at least $43 + 10 \log(P)$ dB.

The specification that emissions shall be attenuated below the transmitter power (P) by at least $43 + 10 \log(P)$ dB, translates in the relevant power range (1 to 0.001 W) to -13 dBm. At 1 W the specified minimum attenuation becomes 43 dB and relative to a 30 dBm (1 W) carrier becomes a limit of -13 dBm. At 0.001 W (0 dBm) the minimum attenuation is 13 dB, which again yields a limit of -13 dBm. In this way a translation of the specification from relative to absolute terms is carried out.

Frequency	Channel	Frequency Range	Verdict
LTE FDD Band 2	Low	9KHz -20GHz	PASS
	Middle	9KHz -20GHz	PASS
	High	9KHz -20GHz	PASS
LTE FDD Band 4	Low	9KHz -18GHz	PASS
	Middle	9KHz -18GHz	PASS
	High	9KHz -18GHz	PASS
LTE FDD Band 12	Low	9KHz -8GHz	PASS
	Middle	9KHz -8GHz	PASS
	High	9KHz -8GHz	PASS

TEST RESULTS

Remark:

1. We were tested all RB Configuration refer 3GPP TS136 521 for each Channel Bandwidth of LTE FDD Band 2, LTE FDD Band 4 and LTE FDD Band 12; recorded worst case for each Channel Bandwidth of LTE FDD Band 2, LTE FDD Band 4 and LTE FDD Band 12.

2. $EIRP = P_{Mea}(dBm) - P_{cl}(dB) + G_a(dBi)$

3. We were not recorded other points as values lower than limits.

4. Margin = EIRP - Limit

LTE FDD Band 2_Channel Bandwidth 1.4MHz_QPSK_Low Channel

Frequency (MHz)	P _{Mea} (dBm)	P _{cl} (dB)	Diatance	G _a Antenna Gain(dB)	Peak EIRP (dBm)	Limit (dBm)	Margin (dB)	Polarization
3701.4	-42.70	5.26	3.00	9.88	-38.08	-13.00	-25.08	H
5552.1	-49.08	6.11	3.00	11.36	-43.83	-13.00	-30.83	H
3701.4	-46.56	5.26	3.00	9.88	-41.94	-13.00	-28.94	V
5552.1	-51.85	6.11	3.00	11.36	-46.60	-13.00	-33.60	V

LTE FDD Band 2_Channel Bandwidth 1.4MHz_QPSK_Middle Channel

Frequency (MHz)	P _{Mea} (dBm)	P _{cl} (dB)	Diatance	G _a Antenna Gain(dB)	Peak EIRP (dBm)	Limit (dBm)	Margin (dB)	Polarization
3760.0	-43.73	5.32	3.00	10.03	-39.02	-13.00	-26.02	H
5640.0	-47.70	6.19	3.00	11.41	-42.48	-13.00	-29.48	H
3760.0	-47.20	5.32	3.00	10.03	-42.49	-13.00	-29.49	V
5640.0	-50.97	6.19	3.00	11.41	-45.75	-13.00	-32.75	V

LTE FDD Band 2_Channel Bandwidth 1.4MHz_QPSK_High Channel

Frequency (MHz)	P _{Mea} (dBm)	P _{cl} (dB)	Diatance	G _a Antenna Gain(dB)	Peak EIRP (dBm)	Limit (dBm)	Margin (dB)	Polarization
3806.6	-42.79	5.36	3.00	9.62	-38.53	-13.00	-25.53	H
5709.9	-46.22	6.24	3.00	11.46	-41.00	-13.00	-28.00	H
3806.6	-46.53	5.36	3.00	9.62	-42.27	-13.00	-29.27	V
5709.9	-51.24	6.24	3.00	11.46	-46.02	-13.00	-33.02	V

LTE FDD Band 2_Channel Bandwidth 3MHz_QPSK_Low Channel

Frequency (MHz)	P _{Mea} (dBm)	P _{cl} (dB)	Diatance	G _a Antenna Gain(dB)	Peak EIRP (dBm)	Limit (dBm)	Margin (dB)	Polarization
3703.0	-42.92	5.26	3.00	9.88	-38.30	-13.00	-25.30	H
5554.5	-48.94	6.11	3.00	11.36	-43.69	-13.00	-30.69	H
3703.0	-46.73	5.26	3.00	9.88	-42.11	-13.00	-29.11	V
5554.5	-51.48	6.11	3.00	11.36	-46.23	-13.00	-33.23	V

LTE FDD Band 2_Channel Bandwidth 3MHz_QPSK_Middle Channel

Frequency (MHz)	P _{Mea} (dBm)	P _{cl} (dB)	Diatance	G _a Antenna Gain(dB)	Peak EIRP (dBm)	Limit (dBm)	Margin (dB)	Polarization
3760.0	-43.64	5.32	3.00	10.03	-38.93	-13.00	-25.93	H
5640.0	-47.77	6.19	3.00	11.41	-42.55	-13.00	-29.55	H
3760.0	-47.03	5.32	3.00	10.03	-42.32	-13.00	-29.32	V
5640.0	-51.05	6.19	3.00	11.41	-45.83	-13.00	-32.83	V

LTE FDD Band 2_Channel Bandwidth 3MHz_QPSK_High Channel

Frequency (MHz)	P _{Mea} (dBm)	P _{cl} (dB)	Diatance	G _a Antenna Gain(dB)	Peak EIRP (dBm)	Limit (dBm)	Margin (dB)	Polarization
3817.0	-42.95	5.36	3.00	9.62	-38.69	-13.00	-25.69	H
5725.5	-46.11	6.24	3.00	11.46	-40.89	-13.00	-27.89	H
3817.0	-46.57	5.36	3.00	9.62	-42.31	-13.00	-29.31	V
5725.5	-51.51	6.24	3.00	11.46	-46.29	-13.00	-33.29	V

LTE FDD Band 2_Channel Bandwidth 5MHz_QPSK_Low Channel

Frequency (MHz)	P _{Mea} (dBm)	P _{cl} (dB)	Diatance	G _a Antenna Gain(dB)	Peak EIRP (dBm)	Limit (dBm)	Margin (dB)	Polarization
3705.0	-42.62	5.26	3.00	9.88	-38.00	-13.00	-25.00	H
5557.5	-49.18	6.11	3.00	11.36	-43.93	-13.00	-30.93	H
3705.0	-46.66	5.26	3.00	9.88	-42.04	-13.00	-29.04	V
5557.5	-51.61	6.11	3.00	11.36	-46.36	-13.00	-33.36	V

LTE FDD Band 2_Channel Bandwidth 5MHz_QPSK_Middle Channel

Frequency (MHz)	P _{Mea} (dBm)	P _{cl} (dB)	Diatance	G _a Antenna Gain(dB)	Peak EIRP (dBm)	Limit (dBm)	Margin (dB)	Polarization
3760.0	-43.51	5.32	3.00	10.03	-38.80	-13.00	-25.80	H
5640.0	-47.84	6.19	3.00	11.41	-42.62	-13.00	-29.62	H
3760.0	-47.17	5.32	3.00	10.03	-42.46	-13.00	-29.46	V
5640.0	-51.03	6.19	3.00	11.41	-45.81	-13.00	-32.81	V

LTE FDD Band 2_Channel Bandwidth 5MHz_QPSK_High Channel

Frequency (MHz)	P _{Mea} (dBm)	P _{cl} (dB)	Diatance	G _a Antenna Gain(dB)	Peak EIRP (dBm)	Limit (dBm)	Margin (dB)	Polarization
3815.0	-42.63	5.36	3.00	9.62	-38.37	-13.00	-25.37	H
5722.5	-46.31	6.24	3.00	11.46	-41.09	-13.00	-28.09	H
3815.0	-46.74	5.36	3.00	9.62	-42.48	-13.00	-29.48	V
5722.5	-51.20	6.24	3.00	11.46	-45.98	-13.00	-32.98	V

LTE FDD Band 2_Channel Bandwidth 10MHz_QPSK_Low Channel

Frequency (MHz)	P _{Mea} (dBm)	P _{cl} (dB)	Diatance	G _a Antenna Gain(dB)	Peak EIRP (dBm)	Limit (dBm)	Margin (dB)	Polarization
3710.0	-42.65	5.26	3.00	9.88	-38.03	-13.00	-25.03	H
5565.0	-49.25	6.11	3.00	11.36	-44.00	-13.00	-31.00	H
3710.0	-46.74	5.26	3.00	9.88	-42.12	-13.00	-29.12	V
5565.0	-51.87	6.11	3.00	11.36	-46.62	-13.00	-33.62	V

LTE FDD Band 2_Channel Bandwidth 10MHz_QPSK_Middle Channel

Frequency (MHz)	P _{Mea} (dBm)	P _{cl} (dB)	Diatance	G _a Antenna Gain(dB)	Peak EIRP (dBm)	Limit (dBm)	Margin (dB)	Polarization
3760.0	-43.70	5.32	3.00	10.03	-38.99	-13.00	-25.99	H
5640.0	-47.99	6.19	3.00	11.41	-42.77	-13.00	-29.77	H
3760.0	-47.14	5.32	3.00	10.03	-42.43	-13.00	-29.43	V
5640.0	-50.89	6.19	3.00	11.41	-45.67	-13.00	-32.67	V

LTE FDD Band 2_Channel Bandwidth 10MHz_QPSK_High Channel

Frequency (MHz)	P _{Mea} (dBm)	P _{cl} (dB)	Diatance	G _a Antenna Gain(dB)	Peak EIRP (dBm)	Limit (dBm)	Margin (dB)	Polarization
3810.0	-42.74	5.36	3.00	9.62	-38.48	-13.00	-25.48	H
5715.0	-46.38	6.24	3.00	11.46	-41.16	-13.00	-28.16	H
3810.0	-46.74	5.36	3.00	9.62	-42.48	-13.00	-29.48	V
5715.0	-51.52	6.24	3.00	11.46	-46.30	-13.00	-33.30	V

LTE FDD Band 2_Channel Bandwidth 15MHz_QPSK_Low Channel

Frequency (MHz)	P _{Mea} (dBm)	P _{cl} (dB)	Diatance	G _a Antenna Gain(dB)	Peak EIRP (dBm)	Limit (dBm)	Margin (dB)	Polarization
3715.0	-42.70	5.26	3.00	9.88	-38.08	-13.00	-25.08	H
5572.5	-49.17	6.11	3.00	11.36	-43.92	-13.00	-30.92	H
3715.0	-46.83	5.26	3.00	9.88	-42.21	-13.00	-29.21	V
5572.5	-51.64	6.11	3.00	11.36	-46.39	-13.00	-33.39	V

LTE FDD Band 2_Channel Bandwidth 15MHz_QPSK_Middle Channel

Frequency (MHz)	P _{Mea} (dBm)	P _{cl} (dB)	Diatance	G _a Antenna Gain(dB)	Peak EIRP (dBm)	Limit (dBm)	Margin (dB)	Polarization
3760.0	-43.56	5.32	3.00	10.03	-38.85	-13.00	-25.85	H
5640.0	-47.74	6.19	3.00	11.41	-42.52	-13.00	-29.52	H
3760.0	-47.18	5.32	3.00	10.03	-42.47	-13.00	-29.47	V
5640.0	-50.92	6.19	3.00	11.41	-45.70	-13.00	-32.70	V

LTE FDD Band 2_Channel Bandwidth 15MHz_QPSK_High Channel

Frequency (MHz)	P _{Mea} (dBm)	P _{cl} (dB)	Diatance	G _a Antenna Gain(dB)	Peak EIRP (dBm)	Limit (dBm)	Margin (dB)	Polarization
3805.0	-42.60	5.36	3.00	9.62	-38.34	-13.00	-25.34	H
5707.5	-46.09	6.24	3.00	11.46	-40.87	-13.00	-27.87	H
3805.0	-46.55	5.36	3.00	9.62	-42.29	-13.00	-29.29	V
5707.5	-51.32	6.24	3.00	11.46	-46.10	-13.00	-33.10	V

LTE FDD Band 2_Channel Bandwidth 20MHz_QPSK_Low Channel

Frequency (MHz)	P _{Mea} (dBm)	P _{cl} (dB)	Diatance	G _a Antenna Gain(dB)	Peak EIRP (dBm)	Limit (dBm)	Margin (dB)	Polarization
3715.0	-42.96	5.26	3.00	9.88	-38.34	-13.00	-25.34	H
5572.5	-49.18	6.11	3.00	11.36	-43.93	-13.00	-30.93	H
3715.0	-46.71	5.26	3.00	9.88	-42.09	-13.00	-29.09	V
5572.5	-51.84	6.11	3.00	11.36	-46.59	-13.00	-33.59	V

LTE FDD Band 2_Channel Bandwidth 20MHz_QPSK_Middle Channel

Frequency (MHz)	P _{Mea} (dBm)	P _{cl} (dB)	Diatance	G _a Antenna Gain(dB)	Peak EIRP (dBm)	Limit (dBm)	Margin (dB)	Polarization
3720.0	-43.65	5.32	3.00	10.03	-38.94	-13.00	-25.94	H
5580.0	-48.05	6.19	3.00	11.41	-42.83	-13.00	-29.83	H
3720.0	-47.20	5.32	3.00	10.03	-42.49	-13.00	-29.49	V
5580.0	-50.92	6.19	3.00	11.41	-45.70	-13.00	-32.70	V

LTE FDD Band 2_Channel Bandwidth 20MHz_QPSK_High Channel

Frequency (MHz)	P _{Mea} (dBm)	P _{cl} (dB)	Diatance	G _a Antenna Gain(dB)	Peak EIRP (dBm)	Limit (dBm)	Margin (dB)	Polarization
3800.0	-42.65	5.36	3.00	9.62	-38.39	-13.00	-25.39	H
5700.0	-46.32	6.24	3.00	11.46	-41.10	-13.00	-28.10	H
3800.0	-46.58	5.36	3.00	9.62	-42.32	-13.00	-29.32	V
5700.0	-51.33	6.24	3.00	11.46	-46.11	-13.00	-33.11	V

LTE FDD Band 2_Channel Bandwidth 1.4MHz_16QAM_Low Channel

Frequency (MHz)	P _{Mea} (dBm)	P _{cl} (dB)	Diatance	G _a Antenna Gain(dB)	Peak EIRP (dBm)	Limit (dBm)	Margin (dB)	Polarization
3701.4	-42.82	5.26	3.00	9.88	-38.20	-13.00	-25.20	H
5552.1	-48.98	6.11	3.00	11.36	-43.73	-13.00	-30.73	H
3701.4	-46.68	5.26	3.00	9.88	-42.06	-13.00	-29.06	V
5552.1	-51.79	6.11	3.00	11.36	-46.54	-13.00	-33.54	V

LTE FDD Band 2_Channel Bandwidth 1.4MHz_16QAM_Middle Channel

Frequency (MHz)	P _{Mea} (dBm)	P _{cl} (dB)	Diatance	G _a Antenna Gain(dB)	Peak EIRP (dBm)	Limit (dBm)	Margin (dB)	Polarization
3760.0	-43.68	5.32	3.00	10.03	-38.97	-13.00	-25.97	H
5640.0	-47.69	6.19	3.00	11.41	-42.47	-13.00	-29.47	H
3760.0	-47.37	5.32	3.00	10.03	-42.66	-13.00	-29.66	V
5640.0	-51.01	6.19	3.00	11.41	-45.79	-13.00	-32.79	V

LTE FDD Band 2_Channel Bandwidth 1.4MHz_16QAM_High Channel

Frequency (MHz)	P _{Mea} (dBm)	P _{cl} (dB)	Diatance	G _a Antenna Gain(dB)	Peak EIRP (dBm)	Limit (dBm)	Margin (dB)	Polarization
3806.6	-42.66	5.36	3.00	9.62	-38.40	-13.00	-25.40	H
5709.9	-46.08	6.24	3.00	11.46	-40.86	-13.00	-27.86	H
3806.6	-46.70	5.36	3.00	9.62	-42.44	-13.00	-29.44	V
5709.9	-51.34	6.24	3.00	11.46	-46.12	-13.00	-33.12	V

LTE FDD Band 2_Channel Bandwidth 3MHz_16QAM_Low Channel

Frequency (MHz)	P _{Mea} (dBm)	P _{cl} (dB)	Diatance	G _a Antenna Gain(dB)	Peak EIRP (dBm)	Limit (dBm)	Margin (dB)	Polarization
3703.0	-42.83	5.26	3.00	9.88	-38.21	-13.00	-25.21	H
5554.5	-49.25	6.11	3.00	11.36	-44.00	-13.00	-31.00	H
3703.0	-46.64	5.26	3.00	9.88	-42.02	-13.00	-29.02	V
5554.5	-51.79	6.11	3.00	11.36	-46.54	-13.00	-33.54	V

LTE FDD Band 2_Channel Bandwidth 3MHz_16QAM_Middle Channel

Frequency (MHz)	P _{Mea} (dBm)	P _{cl} (dB)	Diatance	G _a Antenna Gain(dB)	Peak EIRP (dBm)	Limit (dBm)	Margin (dB)	Polarization
3760.0	-43.48	5.32	3.00	10.03	-38.77	-13.00	-25.77	H
5640.0	-47.85	6.19	3.00	11.41	-42.63	-13.00	-29.63	H
3760.0	-47.08	5.32	3.00	10.03	-42.37	-13.00	-29.37	V
5640.0	-50.84	6.19	3.00	11.41	-45.62	-13.00	-32.62	V

LTE FDD Band 2_Channel Bandwidth 3MHz_16QAM_High Channel

Frequency (MHz)	P _{Mea} (dBm)	P _{cl} (dB)	Diatance	G _a Antenna Gain(dB)	Peak EIRP (dBm)	Limit (dBm)	Margin (dB)	Polarization
3817.0	-42.73	5.36	3.00	9.62	-38.47	-13.00	-25.47	H
5725.5	-46.26	6.24	3.00	11.46	-41.04	-13.00	-28.04	H
3817.0	-46.70	5.36	3.00	9.62	-42.44	-13.00	-29.44	V
5725.5	-51.17	6.24	3.00	11.46	-45.95	-13.00	-32.95	V

LTE FDD Band 2_Channel Bandwidth 5MHz_16QAM_Low Channel

Frequency (MHz)	P _{Mea} (dBm)	P _{cl} (dB)	Diatance	G _a Antenna Gain(dB)	Peak EIRP (dBm)	Limit (dBm)	Margin (dB)	Polarization
3705.0	-43.00	5.26	3.00	9.88	-38.38	-13.00	-25.38	H
5557.5	-49.23	6.11	3.00	11.36	-43.98	-13.00	-30.98	H
3705.0	-46.77	5.26	3.00	9.88	-42.15	-13.00	-29.15	V
5557.5	-51.51	6.11	3.00	11.36	-46.26	-13.00	-33.26	V

LTE FDD Band 2_Channel Bandwidth 5MHz_16QAM_Middle Channel

Frequency (MHz)	P _{Mea} (dBm)	P _{cl} (dB)	Diatance	G _a Antenna Gain(dB)	Peak EIRP (dBm)	Limit (dBm)	Margin (dB)	Polarization
3760.0	-43.47	5.32	3.00	10.03	-38.76	-13.00	-25.76	H
5640.0	-47.99	6.19	3.00	11.41	-42.77	-13.00	-29.77	H
3760.0	-47.34	5.32	3.00	10.03	-42.63	-13.00	-29.63	V
5640.0	-50.88	6.19	3.00	11.41	-45.66	-13.00	-32.66	V

LTE FDD Band 2_Channel Bandwidth 5MHz_16QAM_High Channel

Frequency (MHz)	P _{Mea} (dBm)	P _{cl} (dB)	Diatance	G _a Antenna Gain(dB)	Peak EIRP (dBm)	Limit (dBm)	Margin (dB)	Polarization
3815.0	-42.95	5.36	3.00	9.62	-38.69	-13.00	-25.69	H
5722.5	-46.35	6.24	3.00	11.46	-41.13	-13.00	-28.13	H
3815.0	-46.60	5.36	3.00	9.62	-42.34	-13.00	-29.34	V
5722.5	-51.28	6.24	3.00	11.46	-46.06	-13.00	-33.06	V

LTE FDD Band 2_Channel Bandwidth 10MHz_16QAM_Low Channel

Frequency (MHz)	P _{Mea} (dBm)	P _{cl} (dB)	Diatance	G _a Antenna Gain(dB)	Peak EIRP (dBm)	Limit (dBm)	Margin (dB)	Polarization
3710.0	-42.74	5.26	3.00	9.88	-38.12	-13.00	-25.12	H
5565.0	-49.16	6.11	3.00	11.36	-43.91	-13.00	-30.91	H
3710.0	-46.88	5.26	3.00	9.88	-42.26	-13.00	-29.26	V
5565.0	-51.80	6.11	3.00	11.36	-46.55	-13.00	-33.55	V

LTE FDD Band 2_Channel Bandwidth 10MHz_16QAM_Middle Channel

Frequency (MHz)	P _{Mea} (dBm)	P _{cl} (dB)	Diatance	G _a Antenna Gain(dB)	Peak EIRP (dBm)	Limit (dBm)	Margin (dB)	Polarization
3760.0	-43.49	5.32	3.00	10.03	-38.78	-13.00	-25.78	H
5640.0	-47.92	6.19	3.00	11.41	-42.70	-13.00	-29.70	H
3760.0	-47.12	5.32	3.00	10.03	-42.41	-13.00	-29.41	V
5640.0	-50.97	6.19	3.00	11.41	-45.75	-13.00	-32.75	V

LTE FDD Band 2_Channel Bandwidth 10MHz_16QAM_High Channel

Frequency (MHz)	P _{Mea} (dBm)	P _{cl} (dB)	Diatance	G _a Antenna Gain(dB)	Peak EIRP (dBm)	Limit (dBm)	Margin (dB)	Polarization
3810.0	-42.98	5.36	3.00	9.62	-38.72	-13.00	-25.72	H
5715.0	-46.36	6.24	3.00	11.46	-41.14	-13.00	-28.14	H
3810.0	-46.59	5.36	3.00	9.62	-42.33	-13.00	-29.33	V
5715.0	-51.43	6.24	3.00	11.46	-46.21	-13.00	-33.21	V

LTE FDD Band 2_Channel Bandwidth 15MHz_16QAM_Low Channel

Frequency (MHz)	P _{Mea} (dBm)	P _{cl} (dB)	Diatance	G _a Antenna Gain(dB)	Peak EIRP (dBm)	Limit (dBm)	Margin (dB)	Polarization
3715.0	-42.80	5.26	3.00	9.88	-38.18	-13.00	-25.18	H
5572.5	-49.25	6.11	3.00	11.36	-44.00	-13.00	-31.00	H
3715.0	-46.84	5.26	3.00	9.88	-42.22	-13.00	-29.22	V
5572.5	-51.85	6.11	3.00	11.36	-46.60	-13.00	-33.60	V

LTE FDD Band 2_Channel Bandwidth 15MHz_16QAM_Middle Channel

Frequency (MHz)	P _{Mea} (dBm)	P _{cl} (dB)	Diatance	G _a Antenna Gain(dB)	Peak EIRP (dBm)	Limit (dBm)	Margin (dB)	Polarization
3760.0	-43.49	5.32	3.00	10.03	-38.78	-13.00	-25.78	H
5640.0	-47.93	6.19	3.00	11.41	-42.71	-13.00	-29.71	H
3760.0	-47.28	5.32	3.00	10.03	-42.57	-13.00	-29.57	V
5640.0	-51.09	6.19	3.00	11.41	-45.87	-13.00	-32.87	V

LTE FDD Band 2_Channel Bandwidth 15MHz_16QAM_High Channel

Frequency (MHz)	P _{Mea} (dBm)	P _{cl} (dB)	Diatance	G _a Antenna Gain(dB)	Peak EIRP (dBm)	Limit (dBm)	Margin (dB)	Polarization
3805.0	-42.90	5.36	3.00	9.62	-38.64	-13.00	-25.64	H
5707.5	-46.37	6.24	3.00	11.46	-41.15	-13.00	-28.15	H
3805.0	-46.75	5.36	3.00	9.62	-42.49	-13.00	-29.49	V
5707.5	-51.30	6.24	3.00	11.46	-46.08	-13.00	-33.08	V

LTE FDD Band 2_Channel Bandwidth 20MHz_16QAM_Low Channel

Frequency (MHz)	P _{Mea} (dBm)	P _{cl} (dB)	Diatance	G _a Antenna Gain(dB)	Peak EIRP (dBm)	Limit (dBm)	Margin (dB)	Polarization
3715.0	-42.92	5.26	3.00	9.88	-38.30	-13.00	-25.30	H
5572.5	-49.14	6.11	3.00	11.36	-43.89	-13.00	-30.89	H
3715.0	-46.59	5.26	3.00	9.88	-41.97	-13.00	-28.97	V
5572.5	-51.75	6.11	3.00	11.36	-46.50	-13.00	-33.50	V

LTE FDD Band 2_Channel Bandwidth 20MHz_16QAM_Middle Channel

Frequency (MHz)	P _{Mea} (dBm)	P _{cl} (dB)	Diatance	G _a Antenna Gain(dB)	Peak EIRP (dBm)	Limit (dBm)	Margin (dB)	Polarization
3720.0	-43.64	5.32	3.00	10.03	-38.93	-13.00	-25.93	H
5580.0	-48.00	6.19	3.00	11.41	-42.78	-13.00	-29.78	H
3720.0	-47.13	5.32	3.00	10.03	-42.42	-13.00	-29.42	V
5580.0	-50.88	6.19	3.00	11.41	-45.66	-13.00	-32.66	V

LTE FDD Band 2_Channel Bandwidth 20MHz_16QAM_High Channel

Frequency (MHz)	P _{Mea} (dBm)	P _{cl} (dB)	Diatance	G _a Antenna Gain(dB)	Peak EIRP (dBm)	Limit (dBm)	Margin (dB)	Polarization
3800.0	-42.97	5.36	3.00	9.62	-38.71	-13.00	-25.71	H
5700.0	-46.30	6.24	3.00	11.46	-41.08	-13.00	-28.08	H
3800.0	-46.56	5.36	3.00	9.62	-42.30	-13.00	-29.30	V
5700.0	-51.20	6.24	3.00	11.46	-45.98	-13.00	-32.98	V

LTE FDD Band 4_Channel Bandwidth 1.4MHz_QPSK_Low Channel

Frequency (MHz)	P _{Mea} (dBm)	P _{cl} (dB)	Diatance	G _a Antenna Gain(dB)	Peak EIRP (dBm)	Limit (dBm)	Margin (dB)	Polarization
3421.4	-48.63	4.62	3.00	9.81	-43.44	-13.00	-30.44	H
5132.1	-52.03	5.94	3.00	10.86	-47.11	-13.00	-34.11	H
3421.4	-52.55	4.62	3.00	9.81	-47.36	-13.00	-34.36	V
5132.1	-54.62	5.94	3.00	10.86	-49.70	-13.00	-36.70	V

LTE FDD Band 4_Channel Bandwidth 1.4MHz_QPSK_Middle Channel

Frequency (MHz)	P _{Mea} (dBm)	P _{cl} (dB)	Diatance	G _a Antenna Gain(dB)	Peak EIRP (dBm)	Limit (dBm)	Margin (dB)	Polarization
3465.0	-48.84	4.63	3.00	9.84	-43.63	-13.00	-30.63	H
5197.5	-52.32	5.94	3.00	10.86	-47.40	-13.00	-34.40	H
3465.0	-52.74	4.63	3.00	9.84	-47.53	-13.00	-34.53	V
5197.5	-55.50	5.94	3.00	10.86	-50.58	-13.00	-37.58	V

LTE FDD Band 4_Channel Bandwidth 1.4MHz_QPSK_High Channel

Frequency (MHz)	P _{Mea} (dBm)	P _{cl} (dB)	Diatance	G _a Antenna Gain(dB)	Peak EIRP (dBm)	Limit (dBm)	Margin (dB)	Polarization
3508.6	-52.06	4.65	3.00	9.9	-46.81	-13.00	-33.81	H
5262.9	-53.56	5.95	3.00	10.91	-48.60	-13.00	-35.60	H
3508.6	-54.82	4.65	3.00	9.9	-49.57	-13.00	-36.57	V
5262.9	-56.20	5.95	3.00	10.91	-51.24	-13.00	-38.24	V

LTE FDD Band 4_Channel Bandwidth 3MHz_QPSK_Low Channel

Frequency (MHz)	P _{Mea} (dBm)	P _{cl} (dB)	Diatance	G _a Antenna Gain(dB)	Peak EIRP (dBm)	Limit (dBm)	Margin (dB)	Polarization
3423.0	-48.32	4.62	3.00	9.81	-43.13	-13.00	-30.13	H
5134.5	-51.83	5.94	3.00	10.86	-46.91	-13.00	-33.91	H
3423.0	-52.37	4.62	3.00	9.81	-47.18	-13.00	-34.18	V
5134.5	-54.78	5.94	3.00	10.86	-49.86	-13.00	-36.86	V

LTE FDD Band 4_Channel Bandwidth 3MHz_QPSK_Middle Channel

Frequency (MHz)	P _{Mea} (dBm)	P _{cl} (dB)	Diatance	G _a Antenna Gain(dB)	Peak EIRP (dBm)	Limit (dBm)	Margin (dB)	Polarization
3465.0	-48.97	4.63	3.00	9.84	-43.76	-13.00	-30.76	H
5197.5	-52.59	5.94	3.00	10.86	-47.67	-13.00	-34.67	H
3465.0	-52.68	4.63	3.00	9.84	-47.47	-13.00	-34.47	V
5197.5	-55.38	5.94	3.00	10.86	-50.46	-13.00	-37.46	V

LTE FDD Band 4_Channel Bandwidth 3MHz_QPSK_High Channel

Frequency (MHz)	P _{Mea} (dBm)	P _{cl} (dB)	Diatance	G _a Antenna Gain(dB)	Peak EIRP (dBm)	Limit (dBm)	Margin (dB)	Polarization
3507.0	-52.24	4.65	3.00	9.9	-46.99	-13.00	-33.99	H
5260.5	-53.48	5.95	3.00	10.91	-48.52	-13.00	-35.52	H
3507.0	-54.91	4.65	3.00	9.9	-49.66	-13.00	-36.66	V
5260.5	-56.09	5.95	3.00	10.91	-51.13	-13.00	-38.13	V

LTE FDD Band 4_Channel Bandwidth 5MHz_QPSK_Low Channel

Frequency (MHz)	P _{Mea} (dBm)	P _{cl} (dB)	Diatance	G _a Antenna Gain(dB)	Peak EIRP (dBm)	Limit (dBm)	Margin (dB)	Polarization
3425.0	-48.51	4.62	3.00	9.81	-43.32	-13.00	-30.32	H
5137.5	-52.17	5.94	3.00	10.86	-47.25	-13.00	-34.25	H
3425.0	-52.69	4.62	3.00	9.81	-47.50	-13.00	-34.50	V
5137.5	-54.90	5.94	3.00	10.86	-49.98	-13.00	-36.98	V

LTE FDD Band 4_Channel Bandwidth 5MHz_QPSK_Middle Channel

Frequency (MHz)	P _{Mea} (dBm)	P _{cl} (dB)	Diatance	G _a Antenna Gain(dB)	Peak EIRP (dBm)	Limit (dBm)	Margin (dB)	Polarization
3465.0	-48.91	4.63	3.00	9.84	-43.70	-13.00	-30.70	H
5197.5	-52.54	5.94	3.00	10.86	-47.62	-13.00	-34.62	H
3465.0	-52.64	4.63	3.00	9.84	-47.43	-13.00	-34.43	V
5197.5	-55.23	5.94	3.00	10.86	-50.31	-13.00	-37.31	V

LTE FDD Band 4_Channel Bandwidth 5MHz_QPSK_High Channel

Frequency (MHz)	P _{Mea} (dBm)	P _{cl} (dB)	Diatance	G _a Antenna Gain(dB)	Peak EIRP (dBm)	Limit (dBm)	Margin (dB)	Polarization
3505.0	-52.17	4.65	3.00	9.9	-46.92	-13.00	-33.92	H
5257.5	-53.48	5.95	3.00	10.91	-48.52	-13.00	-35.52	H
3505.0	-54.86	4.65	3.00	9.9	-49.61	-13.00	-36.61	V
5257.5	-55.98	5.95	3.00	10.91	-51.02	-13.00	-38.02	V

LTE FDD Band 4_Channel Bandwidth 10MHz_QPSK_Low Channel

Frequency (MHz)	P _{Mea} (dBm)	P _{cl} (dB)	Diatance	G _a Antenna Gain(dB)	Peak EIRP (dBm)	Limit (dBm)	Margin (dB)	Polarization
3430.0	-48.40	4.62	3.00	9.81	-43.21	-13.00	-30.21	H
5145.0	-51.92	5.94	3.00	10.86	-47.00	-13.00	-34.00	H
3430.0	-52.58	4.62	3.00	9.81	-47.39	-13.00	-34.39	V
5145.0	-54.88	5.94	3.00	10.86	-49.96	-13.00	-36.96	V

LTE FDD Band 4_Channel Bandwidth 10MHz_QPSK_Middle Channel

Frequency (MHz)	P _{Mea} (dBm)	P _{cl} (dB)	Diatance	G _a Antenna Gain(dB)	Peak EIRP (dBm)	Limit (dBm)	Margin (dB)	Polarization
3465.0	-48.68	4.63	3.00	9.84	-43.47	-13.00	-30.47	H
5197.5	-52.35	5.94	3.00	10.86	-47.43	-13.00	-34.43	H
3465.0	-52.94	4.63	3.00	9.84	-47.73	-13.00	-34.73	V
5197.5	-55.26	5.94	3.00	10.86	-50.34	-13.00	-37.34	V

LTE FDD Band 4_Channel Bandwidth 10MHz_QPSK_High Channel

Frequency (MHz)	P _{Mea} (dBm)	P _{cl} (dB)	Diatance	G _a Antenna Gain(dB)	Peak EIRP (dBm)	Limit (dBm)	Margin (dB)	Polarization
3500.0	-52.40	4.65	3.00	9.9	-47.15	-13.00	-34.15	H
5250.0	-53.43	5.95	3.00	10.91	-48.47	-13.00	-35.47	H
3500.0	-55.09	4.65	3.00	9.9	-49.84	-13.00	-36.84	V
5250.0	-55.97	5.95	3.00	10.91	-51.01	-13.00	-38.01	V

LTE FDD Band 4_Channel Bandwidth 15MHz_QPSK_Low Channel

Frequency (MHz)	P _{Mea} (dBm)	P _{cl} (dB)	Diatance	G _a Antenna Gain(dB)	Peak EIRP (dBm)	Limit (dBm)	Margin (dB)	Polarization
3435.0	-48.45	4.62	3.00	9.81	-43.26	-13.00	-30.26	H
5152.5	-51.99	5.94	3.00	10.86	-47.07	-13.00	-34.07	H
3435.0	-52.75	4.62	3.00	9.81	-47.56	-13.00	-34.56	V
5152.5	-54.83	5.94	3.00	10.86	-49.91	-13.00	-36.91	V

LTE FDD Band 4_Channel Bandwidth 15MHz_QPSK_Middle Channel

Frequency (MHz)	P _{Mea} (dBm)	P _{cl} (dB)	Diatance	G _a Antenna Gain(dB)	Peak EIRP (dBm)	Limit (dBm)	Margin (dB)	Polarization
3465.0	-49.00	4.63	3.00	9.84	-43.79	-13.00	-30.79	H
5197.5	-52.46	5.94	3.00	10.86	-47.54	-13.00	-34.54	H
3465.0	-52.70	4.63	3.00	9.84	-47.49	-13.00	-34.49	V
5197.5	-55.36	5.94	3.00	10.86	-50.44	-13.00	-37.44	V

LTE FDD Band 4_Channel Bandwidth 15MHz_QPSK_High Channel

Frequency (MHz)	P _{Mea} (dBm)	P _{cl} (dB)	Diatance	G _a Antenna Gain(dB)	Peak EIRP (dBm)	Limit (dBm)	Margin (dB)	Polarization
3495.0	-52.07	4.65	3.00	9.9	-46.82	-13.00	-33.82	H
5242.5	-53.40	5.95	3.00	10.91	-48.44	-13.00	-35.44	H
3495.0	-55.11	4.65	3.00	9.9	-49.86	-13.00	-36.86	V
5242.5	-56.02	5.95	3.00	10.91	-51.06	-13.00	-38.06	V

LTE FDD Band 4_Channel Bandwidth 20MHz_QPSK_Low Channel

Frequency (MHz)	P _{Mea} (dBm)	P _{cl} (dB)	Diatance	G _a Antenna Gain(dB)	Peak EIRP (dBm)	Limit (dBm)	Margin (dB)	Polarization
3440.0	-48.28	4.62	3.00	9.81	-43.09	-13.00	-30.09	H
5160.0	-51.91	5.94	3.00	10.86	-46.99	-13.00	-33.99	H
3440.0	-52.53	4.62	3.00	9.81	-47.34	-13.00	-34.34	V
5160.0	-54.75	5.94	3.00	10.86	-49.83	-13.00	-36.83	V

LTE FDD Band 4_Channel Bandwidth 20MHz_QPSK_Middle Channel

Frequency (MHz)	P _{Mea} (dBm)	P _{cl} (dB)	Diatance	G _a Antenna Gain(dB)	Peak EIRP (dBm)	Limit (dBm)	Margin (dB)	Polarization
3465.0	-48.94	4.63	3.00	9.84	-43.73	-13.00	-30.73	H
5197.5	-52.39	5.94	3.00	10.86	-47.47	-13.00	-34.47	H
3465.0	-53.02	4.63	3.00	9.84	-47.81	-13.00	-34.81	V
5197.5	-55.42	5.94	3.00	10.86	-50.50	-13.00	-37.50	V

LTE FDD Band 4_Channel Bandwidth 20MHz_QPSK_High Channel

Frequency (MHz)	P _{Mea} (dBm)	P _{cl} (dB)	Diatance	G _a Antenna Gain(dB)	Peak EIRP (dBm)	Limit (dBm)	Margin (dB)	Polarization
3490.0	-52.40	4.65	3.00	9.9	-47.15	-13.00	-34.15	H
5235.0	-53.24	5.95	3.00	10.91	-48.28	-13.00	-35.28	H
3490.0	-55.08	4.65	3.00	9.9	-49.83	-13.00	-36.83	V
5235.0	-56.03	5.95	3.00	10.91	-51.07	-13.00	-38.07	V

LTE FDD Band 4_Channel Bandwidth 1.4MHz_16QAM_Low Channel

Frequency (MHz)	P _{Mea} (dBm)	P _{cl} (dB)	Diatance	G _a Antenna Gain(dB)	Peak EIRP (dBm)	Limit (dBm)	Margin (dB)	Polarization
3421.4	-48.59	4.62	3.00	9.81	-43.40	-13.00	-30.40	H
5132.1	-51.88	5.94	3.00	10.86	-46.96	-13.00	-33.96	H
3421.4	-52.48	4.62	3.00	9.81	-47.29	-13.00	-34.29	V
5132.1	-54.96	5.94	3.00	10.86	-50.04	-13.00	-37.04	V

LTE FDD Band 4_Channel Bandwidth 1.4MHz_16QAM_Middle Channel

Frequency (MHz)	P _{Mea} (dBm)	P _{cl} (dB)	Diatance	G _a Antenna Gain(dB)	Peak EIRP (dBm)	Limit (dBm)	Margin (dB)	Polarization
3465.0	-49.02	4.63	3.00	9.84	-43.81	-13.00	-30.81	H
5197.5	-52.54	5.94	3.00	10.86	-47.62	-13.00	-34.62	H
3465.0	-52.98	4.63	3.00	9.84	-47.77	-13.00	-34.77	V
5197.5	-55.34	5.94	3.00	10.86	-50.42	-13.00	-37.42	V

LTE FDD Band 4_Channel Bandwidth 1.4MHz_16QAM_High Channel

Frequency (MHz)	P _{Mea} (dBm)	P _{cl} (dB)	Diatance	G _a Antenna Gain(dB)	Peak EIRP (dBm)	Limit (dBm)	Margin (dB)	Polarization
3508.6	-52.06	4.65	3.00	9.9	-46.81	-13.00	-33.81	H
5262.9	-53.31	5.95	3.00	10.91	-48.35	-13.00	-35.35	H
3508.6	-54.77	4.65	3.00	9.9	-49.52	-13.00	-36.52	V
5262.9	-55.91	5.95	3.00	10.91	-50.95	-13.00	-37.95	V

LTE FDD Band 4_Channel Bandwidth 3MHz_16QAM_Low Channel

Frequency (MHz)	P _{Mea} (dBm)	P _{cl} (dB)	Diatance	G _a Antenna Gain(dB)	Peak EIRP (dBm)	Limit (dBm)	Margin (dB)	Polarization
3423.0	-48.55	4.62	3.00	9.81	-43.36	-13.00	-30.36	H
5134.5	-52.00	5.94	3.00	10.86	-47.08	-13.00	-34.08	H
3423.0	-52.39	4.62	3.00	9.81	-47.20	-13.00	-34.20	V
5134.5	-54.91	5.94	3.00	10.86	-49.99	-13.00	-36.99	V

LTE FDD Band 4_Channel Bandwidth 3MHz_16QAM_Middle Channel

Frequency (MHz)	P _{Mea} (dBm)	P _{cl} (dB)	Diatance	G _a Antenna Gain(dB)	Peak EIRP (dBm)	Limit (dBm)	Margin (dB)	Polarization
3465.0	-48.74	4.63	3.00	9.84	-43.53	-13.00	-30.53	H
5197.5	-52.29	5.94	3.00	10.86	-47.37	-13.00	-34.37	H
3465.0	-52.74	4.63	3.00	9.84	-47.53	-13.00	-34.53	V
5197.5	-55.34	5.94	3.00	10.86	-50.42	-13.00	-37.42	V

LTE FDD Band 4_Channel Bandwidth 3MHz_16QAM_High Channel

Frequency (MHz)	P _{Mea} (dBm)	P _{cl} (dB)	Diatance	G _a Antenna Gain(dB)	Peak EIRP (dBm)	Limit (dBm)	Margin (dB)	Polarization
3507.0	-52.35	4.65	3.00	9.9	-47.10	-13.00	-34.10	H
5260.5	-53.53	5.95	3.00	10.91	-48.57	-13.00	-35.57	H
3507.0	-55.11	4.65	3.00	9.9	-49.86	-13.00	-36.86	V
5260.5	-56.04	5.95	3.00	10.91	-51.08	-13.00	-38.08	V

LTE FDD Band 4_Channel Bandwidth 5MHz_16QAM_Low Channel

Frequency (MHz)	P _{Mea} (dBm)	P _{cl} (dB)	Diatance	G _a Antenna Gain(dB)	Peak EIRP (dBm)	Limit (dBm)	Margin (dB)	Polarization
3425.0	-48.30	4.62	3.00	9.81	-43.11	-13.00	-30.11	H
5137.5	-51.92	5.94	3.00	10.86	-47.00	-13.00	-34.00	H
3425.0	-52.45	4.62	3.00	9.81	-47.26	-13.00	-34.26	V
5137.5	-54.96	5.94	3.00	10.86	-50.04	-13.00	-37.04	V

LTE FDD Band 4_Channel Bandwidth 5MHz_16QAM_Middle Channel

Frequency (MHz)	P _{Mea} (dBm)	P _{cl} (dB)	Diatance	G _a Antenna Gain(dB)	Peak EIRP (dBm)	Limit (dBm)	Margin (dB)	Polarization
3465.0	-49.01	4.63	3.00	9.84	-43.80	-13.00	-30.80	H
5197.5	-52.53	5.94	3.00	10.86	-47.61	-13.00	-34.61	H
3465.0	-53.00	4.63	3.00	9.84	-47.79	-13.00	-34.79	V
5197.5	-55.14	5.94	3.00	10.86	-50.22	-13.00	-37.22	V

LTE FDD Band 4_Channel Bandwidth 5MHz_16QAM_High Channel

Frequency (MHz)	P _{Mea} (dBm)	P _{cl} (dB)	Diatance	G _a Antenna Gain(dB)	Peak EIRP (dBm)	Limit (dBm)	Margin (dB)	Polarization
3505.0	-52.38	4.65	3.00	9.9	-47.13	-13.00	-34.13	H
5257.5	-53.37	5.95	3.00	10.91	-48.41	-13.00	-35.41	H
3505.0	-54.96	4.65	3.00	9.9	-49.71	-13.00	-36.71	V
5257.5	-55.91	5.95	3.00	10.91	-50.95	-13.00	-37.95	V

LTE FDD Band 4_Channel Bandwidth 10MHz_16QAM_Low Channel

Frequency (MHz)	P _{Mea} (dBm)	P _{cl} (dB)	Diatance	G _a Antenna Gain(dB)	Peak EIRP (dBm)	Limit (dBm)	Margin (dB)	Polarization
3430.0	-48.25	4.62	3.00	9.81	-43.06	-13.00	-30.06	H
5145.0	-52.10	5.94	3.00	10.86	-47.18	-13.00	-34.18	H
3430.0	-52.56	4.62	3.00	9.81	-47.37	-13.00	-34.37	V
5145.0	-54.95	5.94	3.00	10.86	-50.03	-13.00	-37.03	V

LTE FDD Band 4_Channel Bandwidth 10MHz_16QAM_Middle Channel

Frequency (MHz)	P _{Mea} (dBm)	P _{cl} (dB)	Diatance	G _a Antenna Gain(dB)	Peak EIRP (dBm)	Limit (dBm)	Margin (dB)	Polarization
3465.0	-48.78	4.63	3.00	9.84	-43.57	-13.00	-30.57	H
5197.5	-52.38	5.94	3.00	10.86	-47.46	-13.00	-34.46	H
3465.0	-52.81	4.63	3.00	9.84	-47.60	-13.00	-34.60	V
5197.5	-55.14	5.94	3.00	10.86	-50.22	-13.00	-37.22	V

LTE FDD Band 4_Channel Bandwidth 10MHz_16QAM_High Channel

Frequency (MHz)	P _{Mea} (dBm)	P _{cl} (dB)	Diatance	G _a Antenna Gain(dB)	Peak EIRP (dBm)	Limit (dBm)	Margin (dB)	Polarization
3500.0	-52.18	4.65	3.00	9.9	-46.93	-13.00	-33.93	H
5250.0	-53.44	5.95	3.00	10.91	-48.48	-13.00	-35.48	H
3500.0	-55.02	4.65	3.00	9.9	-49.77	-13.00	-36.77	V
5250.0	-55.92	5.95	3.00	10.91	-50.96	-13.00	-37.96	V

LTE FDD Band 4_Channel Bandwidth 15MHz_16QAM_Low Channel

Frequency (MHz)	P _{Mea} (dBm)	P _{cl} (dB)	Diatance	G _a Antenna Gain(dB)	Peak EIRP (dBm)	Limit (dBm)	Margin (dB)	Polarization
3435.0	-48.48	4.62	3.00	9.81	-43.29	-13.00	-30.29	H
5152.5	-52.09	5.94	3.00	10.86	-47.17	-13.00	-34.17	H
3435.0	-52.76	4.62	3.00	9.81	-47.57	-13.00	-34.57	V
5152.5	-54.73	5.94	3.00	10.86	-49.81	-13.00	-36.81	V

LTE FDD Band 4_Channel Bandwidth 15MHz_16QAM_Middle Channel

Frequency (MHz)	P _{Mea} (dBm)	P _{cl} (dB)	Diatance	G _a Antenna Gain(dB)	Peak EIRP (dBm)	Limit (dBm)	Margin (dB)	Polarization
3465.0	-49.03	4.63	3.00	9.84	-43.82	-13.00	-30.82	H
5197.5	-52.55	5.94	3.00	10.86	-47.63	-13.00	-34.63	H
3465.0	-52.81	4.63	3.00	9.84	-47.60	-13.00	-34.60	V
5197.5	-55.42	5.94	3.00	10.86	-50.50	-13.00	-37.50	V

LTE FDD Band 4_Channel Bandwidth 15MHz_16QAM_High Channel

Frequency (MHz)	P _{Mea} (dBm)	P _{cl} (dB)	Diatance	G _a Antenna Gain(dB)	Peak EIRP (dBm)	Limit (dBm)	Margin (dB)	Polarization
3495.0	-52.12	4.65	3.00	9.9	-46.87	-13.00	-33.87	H
5242.5	-53.59	5.95	3.00	10.91	-48.63	-13.00	-35.63	H
3495.0	-54.79	4.65	3.00	9.9	-49.54	-13.00	-36.54	V
5242.5	-56.02	5.95	3.00	10.91	-51.06	-13.00	-38.06	V

LTE FDD Band 4_Channel Bandwidth 20MHz_16QAM_Low Channel

Frequency (MHz)	P _{Mea} (dBm)	P _{cl} (dB)	Diatance	G _a Antenna Gain(dB)	Peak EIRP (dBm)	Limit (dBm)	Margin (dB)	Polarization
3440.0	-48.56	4.62	3.00	9.81	-43.37	-13.00	-30.37	H
5160.0	-51.97	5.94	3.00	10.86	-47.05	-13.00	-34.05	H
3440.0	-52.76	4.62	3.00	9.81	-47.57	-13.00	-34.57	V
5160.0	-54.81	5.94	3.00	10.86	-49.89	-13.00	-36.89	V

LTE FDD Band 4_Channel Bandwidth 20MHz_16QAM_Middle Channel

Frequency (MHz)	P _{Mea} (dBm)	P _{cl} (dB)	Diatance	G _a Antenna Gain(dB)	Peak EIRP (dBm)	Limit (dBm)	Margin (dB)	Polarization
3465.0	-49.07	4.63	3.00	9.84	-43.86	-13.00	-30.86	H
5197.5	-52.54	5.94	3.00	10.86	-47.62	-13.00	-34.62	H
3465.0	-52.65	4.63	3.00	9.84	-47.44	-13.00	-34.44	V
5197.5	-55.53	5.94	3.00	10.86	-50.61	-13.00	-37.61	V

LTE FDD Band 4_Channel Bandwidth 20MHz_16QAM_High Channel

Frequency (MHz)	P _{Mea} (dBm)	P _{cl} (dB)	Diatance	G _a Antenna Gain(dB)	Peak EIRP (dBm)	Limit (dBm)	Margin (dB)	Polarization
3490.0	-52.10	4.65	3.00	9.9	-46.85	-13.00	-33.85	H
5235.0	-53.28	5.95	3.00	10.91	-48.32	-13.00	-35.32	H
3490.0	-54.90	4.65	3.00	9.9	-49.65	-13.00	-36.65	V
5235.0	-55.95	5.95	3.00	10.91	-50.99	-13.00	-37.99	V

LTE FDD Band 12_Channel Bandwidth 1.4MHz_QPSK_Low Channel

Frequency (MHz)	P _{Mea} (dBm)	P _{cl} (dB)	Diatance	G _a Antenna Gain(dB)	Peak EIRP (dBm)	Limit (dBm)	Margin (dB)	Polarization
1399.40	-40.93	4.73	3.00	10.42	-35.24	-13.00	-22.24	H
2099.10	-47.89	5.64	3.00	12.30	-41.23	-13.00	-28.23	H
1399.40	-43.79	4.73	3.00	10.42	-38.10	-13.00	-25.10	V
2099.10	-50.22	5.64	3.00	12.30	-43.56	-13.00	-30.56	V

LTE FDD Band 12_Channel Bandwidth 1.4MHz_QPSK_Middle Channel

Frequency (MHz)	P _{Mea} (dBm)	P _{cl} (dB)	Diatance	G _a Antenna Gain(dB)	Peak EIRP (dBm)	Limit (dBm)	Margin (dB)	Polarization
1415.00	-39.92	4.75	3.00	10.44	-34.23	-13.00	-21.23	H
2122.50	-44.10	5.66	3.00	12.33	-37.43	-13.00	-24.43	H
1415.00	-44.14	4.75	3.00	10.44	-38.45	-13.00	-25.45	V
2122.50	-47.86	5.66	3.00	12.33	-41.19	-13.00	-28.19	V

LTE FDD Band 12_Channel Bandwidth 1.4MHz_QPSK_High Channel

Frequency (MHz)	P _{Mea} (dBm)	P _{cl} (dB)	Diatance	G _a Antenna Gain(dB)	Peak EIRP (dBm)	Limit (dBm)	Margin (dB)	Polarization
1430.60	-39.33	4.77	3.00	10.45	-33.65	-13.00	-20.65	H
2145.90	-44.36	5.69	3.00	12.36	-37.69	-13.00	-24.69	H
1430.60	-44.52	4.77	3.00	10.45	-38.84	-13.00	-25.84	V
2145.90	-50.02	5.69	3.00	12.36	-43.35	-13.00	-30.35	V

LTE FDD Band 12_Channel Bandwidth 3MHz_QPSK_Low Channel

Frequency (MHz)	P _{Mea} (dBm)	P _{cl} (dB)	Diatance	G _a Antenna Gain(dB)	Peak EIRP (dBm)	Limit (dBm)	Margin (dB)	Polarization
1401.00	-41.15	4.73	3.00	10.42	-35.46	-13.00	-22.46	H
2101.50	-47.83	5.64	3.00	12.30	-41.17	-13.00	-28.17	H
1401.00	-43.98	4.73	3.00	10.42	-38.29	-13.00	-25.29	V
2101.50	-50.24	5.64	3.00	12.30	-43.58	-13.00	-30.58	V

LTE FDD Band 12_Channel Bandwidth 3MHz_QPSK_Middle Channel

Frequency (MHz)	P _{Mea} (dBm)	P _{cl} (dB)	Diatance	G _a Antenna Gain(dB)	Peak EIRP (dBm)	Limit (dBm)	Margin (dB)	Polarization
1415.00	-40.07	4.75	3.00	10.44	-34.38	-13.00	-21.38	H
2122.50	-44.19	5.66	3.00	12.33	-37.52	-13.00	-24.52	H
1415.00	-44.16	4.75	3.00	10.44	-38.47	-13.00	-25.47	V
2122.50	-47.77	5.66	3.00	12.33	-41.10	-13.00	-28.10	V

LTE FDD Band 12_Channel Bandwidth 3MHz_QPSK_High Channel

Frequency (MHz)	P _{Mea} (dBm)	P _{cl} (dB)	Diatance	G _a Antenna Gain(dB)	Peak EIRP (dBm)	Limit (dBm)	Margin (dB)	Polarization
1429.00	-39.43	4.77	3.00	10.45	-33.75	-13.00	-20.75	H
2143.50	-44.45	5.69	3.00	12.36	-37.78	-13.00	-24.78	H
1429.00	-44.71	4.77	3.00	10.45	-39.03	-13.00	-26.03	V
2143.50	-50.00	5.69	3.00	12.36	-43.33	-13.00	-30.33	V

LTE FDD Band 12_Channel Bandwidth 5MHz_QPSK_Low Channel

Frequency (MHz)	P _{Mea} (dBm)	P _{cl} (dB)	Diatance	G _a Antenna Gain(dB)	Peak EIRP (dBm)	Limit (dBm)	Margin (dB)	Polarization
1403.00	-41.00	4.73	3.00	10.42	-35.31	-13.00	-22.31	H
2104.50	-47.62	5.64	3.00	12.30	-40.96	-13.00	-27.96	H
1403.00	-43.73	4.73	3.00	10.42	-38.04	-13.00	-25.04	V
2104.50	-50.38	5.64	3.00	12.30	-43.72	-13.00	-30.72	V

LTE FDD Band 12_Channel Bandwidth 5MHz_QPSK_Middle Channel

Frequency (MHz)	P _{Mea} (dBm)	P _{cl} (dB)	Diatance	G _a Antenna Gain(dB)	Peak EIRP (dBm)	Limit (dBm)	Margin (dB)	Polarization
1415.00	-39.75	4.75	3.00	10.44	-34.06	-13.00	-21.06	H
2122.50	-44.34	5.66	3.00	12.33	-37.67	-13.00	-24.67	H
1415.00	-43.87	4.75	3.00	10.44	-38.18	-13.00	-25.18	V
2122.50	-47.82	5.66	3.00	12.33	-41.15	-13.00	-28.15	V

LTE FDD Band 12_Channel Bandwidth 5MHz_QPSK_High Channel

Frequency (MHz)	P _{Mea} (dBm)	P _{cl} (dB)	Diatance	G _a Antenna Gain(dB)	Peak EIRP (dBm)	Limit (dBm)	Margin (dB)	Polarization
1427.00	-39.60	4.77	3.00	10.45	-33.92	-13.00	-20.92	H
2140.50	-44.55	5.69	3.00	12.36	-37.88	-13.00	-24.88	H
1427.00	-44.88	4.77	3.00	10.45	-39.20	-13.00	-26.20	V
2140.50	-50.25	5.69	3.00	12.36	-43.58	-13.00	-30.58	V

LTE FDD Band 12_Channel Bandwidth 10MHz_QPSK_Low Channel

Frequency (MHz)	P _{Mea} (dBm)	P _{cl} (dB)	Diatance	G _a Antenna Gain(dB)	Peak EIRP (dBm)	Limit (dBm)	Margin (dB)	Polarization
1408.00	-41.10	4.73	3.00	10.42	-35.41	-13.00	-22.41	H
2112.00	-47.92	5.64	3.00	12.30	-41.26	-13.00	-28.26	H
1408.00	-44.04	4.73	3.00	10.42	-38.35	-13.00	-25.35	V
2112.00	-50.25	5.64	3.00	12.30	-43.59	-13.00	-30.59	V

LTE FDD Band 12_Channel Bandwidth 10MHz_QPSK_Middle Channel

Frequency (MHz)	P _{Mea} (dBm)	P _{cl} (dB)	Diatance	G _a Antenna Gain(dB)	Peak EIRP (dBm)	Limit (dBm)	Margin (dB)	Polarization
1415.00	-39.74	4.75	3.00	10.44	-34.05	-13.00	-21.05	H
2122.50	-44.17	5.66	3.00	12.33	-37.50	-13.00	-24.50	H
1415.00	-44.15	4.75	3.00	10.44	-38.46	-13.00	-25.46	V
2122.50	-47.95	5.66	3.00	12.33	-41.28	-13.00	-28.28	V

LTE FDD Band 12_Channel Bandwidth 10MHz_QPSK_High Channel

Frequency (MHz)	P _{Mea} (dBm)	P _{cl} (dB)	Diatance	G _a Antenna Gain(dB)	Peak EIRP (dBm)	Limit (dBm)	Margin (dB)	Polarization
1422.00	-39.32	4.77	3.00	10.45	-33.64	-13.00	-20.64	H
2133.00	-44.69	5.69	3.00	12.36	-38.02	-13.00	-25.02	H
1422.00	-44.58	4.77	3.00	10.45	-38.90	-13.00	-25.90	V
2133.00	-49.99	5.69	3.00	12.36	-43.32	-13.00	-30.32	V

LTE FDD Band 12_Channel Bandwidth 1.4MHz_16QAM_Low Channel

Frequency (MHz)	P _{Mea} (dBm)	P _{cl} (dB)	Diatance	G _a Antenna Gain(dB)	Peak EIRP (dBm)	Limit (dBm)	Margin (dB)	Polarization
1399.40	-41.04	4.73	3.00	10.42	-35.35	-13.00	-22.35	H
2099.10	-47.75	5.64	3.00	12.30	-41.09	-13.00	-28.09	H
1399.40	-43.98	4.73	3.00	10.42	-38.29	-13.00	-25.29	V
2099.10	-50.40	5.64	3.00	12.30	-43.74	-13.00	-30.74	V

LTE FDD Band 12_Channel Bandwidth 1.4MHz_16QAM_Middle Channel

Frequency (MHz)	P _{Mea} (dBm)	P _{cl} (dB)	Diatance	G _a Antenna Gain(dB)	Peak EIRP (dBm)	Limit (dBm)	Margin (dB)	Polarization
1415.00	-39.99	4.75	3.00	10.44	-34.30	-13.00	-21.30	H
2122.50	-44.10	5.66	3.00	12.33	-37.43	-13.00	-24.43	H
1415.00	-43.97	4.75	3.00	10.44	-38.28	-13.00	-25.28	V
2122.50	-47.86	5.66	3.00	12.33	-41.19	-13.00	-28.19	V

LTE FDD Band 12_Channel Bandwidth 1.4MHz_16QAM_High Channel

Frequency (MHz)	P _{Mea} (dBm)	P _{cl} (dB)	Diatance	G _a Antenna Gain(dB)	Peak EIRP (dBm)	Limit (dBm)	Margin (dB)	Polarization
1430.60	-39.29	4.77	3.00	10.45	-33.61	-13.00	-20.61	H
2145.90	-44.70	5.69	3.00	12.36	-38.03	-13.00	-25.03	H
1430.60	-44.89	4.77	3.00	10.45	-39.21	-13.00	-26.21	V
2145.90	-50.35	5.69	3.00	12.36	-43.68	-13.00	-30.68	V

LTE FDD Band 12_Channel Bandwidth 3MHz_16QAM_Low Channel

Frequency (MHz)	P _{Mea} (dBm)	P _{cl} (dB)	Diatance	G _a Antenna Gain(dB)	Peak EIRP (dBm)	Limit (dBm)	Margin (dB)	Polarization
1401.00	-40.90	4.73	3.00	10.42	-35.21	-13.00	-22.21	H
2101.50	-47.58	5.64	3.00	12.30	-40.92	-13.00	-27.92	H
1401.00	-43.77	4.73	3.00	10.42	-38.08	-13.00	-25.08	V
2101.50	-50.30	5.64	3.00	12.30	-43.64	-13.00	-30.64	V

LTE FDD Band 12_Channel Bandwidth 3MHz_16QAM_Middle Channel

Frequency (MHz)	P _{Mea} (dBm)	P _{cl} (dB)	Diatance	G _a Antenna Gain(dB)	Peak EIRP (dBm)	Limit (dBm)	Margin (dB)	Polarization
1415.00	-39.94	4.75	3.00	10.44	-34.25	-13.00	-21.25	H
2122.50	-44.12	5.66	3.00	12.33	-37.45	-13.00	-24.45	H
1415.00	-44.17	4.75	3.00	10.44	-38.48	-13.00	-25.48	V
2122.50	-47.69	5.66	3.00	12.33	-41.02	-13.00	-28.02	V

LTE FDD Band 12_Channel Bandwidth 3MHz_16QAM_High Channel

Frequency (MHz)	P _{Mea} (dBm)	P _{cl} (dB)	Diatance	G _a Antenna Gain(dB)	Peak EIRP (dBm)	Limit (dBm)	Margin (dB)	Polarization
1429.00	-39.29	4.77	3.00	10.45	-33.61	-13.00	-20.61	H
2143.50	-44.70	5.69	3.00	12.36	-38.03	-13.00	-25.03	H
1429.00	-44.51	4.77	3.00	10.45	-38.83	-13.00	-25.83	V
2143.50	-50.31	5.69	3.00	12.36	-43.64	-13.00	-30.64	V

LTE FDD Band 12_Channel Bandwidth 5MHz_16QAM_Low Channel

Frequency (MHz)	P _{Mea} (dBm)	P _{cl} (dB)	Diatance	G _a Antenna Gain(dB)	Peak EIRP (dBm)	Limit (dBm)	Margin (dB)	Polarization
1403.00	-40.93	4.73	3.00	10.42	-35.24	-13.00	-22.24	H
2104.50	-47.66	5.64	3.00	12.30	-41.00	-13.00	-28.00	H
1403.00	-43.70	4.73	3.00	10.42	-38.01	-13.00	-25.01	V
2104.50	-50.20	5.64	3.00	12.30	-43.54	-13.00	-30.54	V

LTE FDD Band 12_Channel Bandwidth 5MHz_16QAM_Middle Channel

Frequency (MHz)	P _{Mea} (dBm)	P _{cl} (dB)	Diatance	G _a Antenna Gain(dB)	Peak EIRP (dBm)	Limit (dBm)	Margin (dB)	Polarization
1415.00	-39.81	4.75	3.00	10.44	-34.12	-13.00	-21.12	H
2122.50	-44.12	5.66	3.00	12.33	-37.45	-13.00	-24.45	H
1415.00	-43.99	4.75	3.00	10.44	-38.30	-13.00	-25.30	V
2122.50	-48.04	5.66	3.00	12.33	-41.37	-13.00	-28.37	V

LTE FDD Band 12_Channel Bandwidth 5MHz_16QAM_High Channel

Frequency (MHz)	P _{Mea} (dBm)	P _{cl} (dB)	Diatance	G _a Antenna Gain(dB)	Peak EIRP (dBm)	Limit (dBm)	Margin (dB)	Polarization
1427.00	-39.59	4.77	3.00	10.45	-33.91	-13.00	-20.91	H
2140.50	-44.38	5.69	3.00	12.36	-37.71	-13.00	-24.71	H
1427.00	-44.68	4.77	3.00	10.45	-39.00	-13.00	-26.00	V
2140.50	-50.36	5.69	3.00	12.36	-43.69	-13.00	-30.69	V

LTE FDD Band 12_Channel Bandwidth 10MHz_16QAM_Low Channel

Frequency (MHz)	P _{Mea} (dBm)	P _{cl} (dB)	Diatance	G _a Antenna Gain(dB)	Peak EIRP (dBm)	Limit (dBm)	Margin (dB)	Polarization
1408.00	-41.15	4.73	3.00	10.42	-35.46	-13.00	-22.46	H
2112.00	-47.71	5.64	3.00	12.30	-41.05	-13.00	-28.05	H
1408.00	-44.06	4.73	3.00	10.42	-38.37	-13.00	-25.37	V
2112.00	-50.48	5.64	3.00	12.30	-43.82	-13.00	-30.82	V

LTE FDD Band 12_Channel Bandwidth 10MHz_16QAM_Middle Channel

Frequency (MHz)	P _{Mea} (dBm)	P _{cl} (dB)	Diatance	G _a Antenna Gain(dB)	Peak EIRP (dBm)	Limit (dBm)	Margin (dB)	Polarization
1415.00	-39.79	4.75	3.00	10.44	-34.10	-13.00	-21.10	H
2122.50	-44.27	5.66	3.00	12.33	-37.60	-13.00	-24.60	H
1415.00	-43.90	4.75	3.00	10.44	-38.21	-13.00	-25.21	V
2122.50	-47.71	5.66	3.00	12.33	-41.04	-13.00	-28.04	V

LTE FDD Band 12_Channel Bandwidth 10MHz_16QAM_High Channel

Frequency (MHz)	P _{Mea} (dBm)	P _{cl} (dB)	Diatance	G _a Antenna Gain(dB)	Peak EIRP (dBm)	Limit (dBm)	Margin (dB)	Polarization
1422.00	-39.39	4.77	3.00	10.45	-33.71	-13.00	-20.71	H
2133.00	-44.51	5.69	3.00	12.36	-37.84	-13.00	-24.84	H
1422.00	-44.72	4.77	3.00	10.45	-39.04	-13.00	-26.04	V
2133.00	-50.04	5.69	3.00	12.36	-43.37	-13.00	-30.37	V

4.7 Frequency Stability under Temperature & Voltage Variations

LIMIT

According to FCC §2.1055, §22.355, §24.235 and §27.54 requirement, the frequency stability shall be sufficient to ensure that the fundamental emissions stay within the authorized bands of operation and should not exceed 2.5ppm.

TEST CONFIGURATION

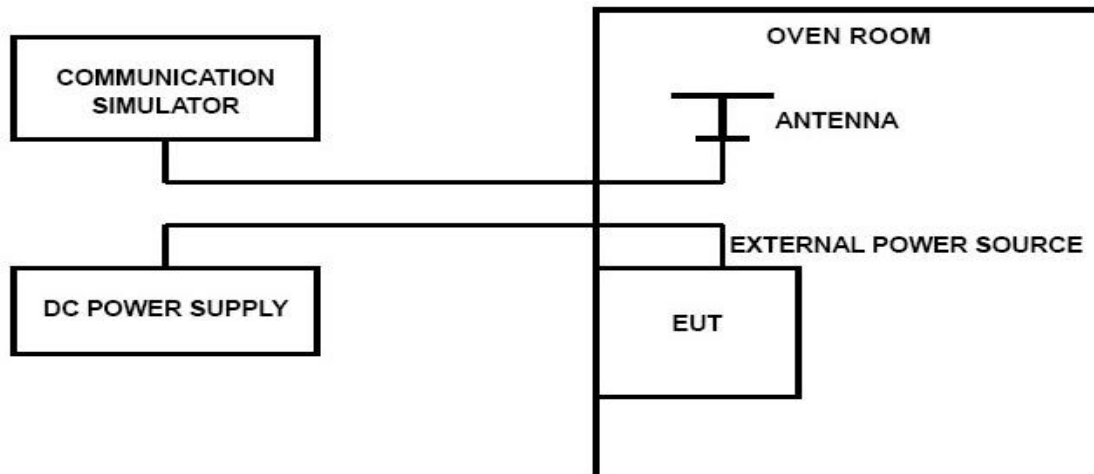

TEST PROCEDURE

The EUT was setup according to TIA-603-E

Frequency Stability Under Temperature Variations:

In order to measure the carrier frequency under the condition of AFC lock, it is necessary to make measurements with the EUT in a "call mode". This is accomplished with the use of R&S CMW500 DIGITAL RADIO COMMUNICATION TESTER.

1. Measure the carrier frequency at room temperature.
2. Subject the EUT to overnight soak at -30°C.
3. With the EUT, powered via nominal voltage, connected to the CMW500 and in a simulated call on middle channel for LTE band 2, LTE band 4 and LTE band 12; measure the carrier frequency. These measurements should be made within 2 minutes of Powering up the EUT, to prevent significant self-warming.
4. Repeat the above measurements at 10°C increments from -30°C to +50°C. Allow at least 1.5 hours at each temperature, unpowered, before making measurements.
5. Re-measure carrier frequency at room temperature with nominal voltage. Vary supply voltage from minimum voltage to maximum voltage, in 0.1Volt increments re-measuring carrier frequency at each voltage. Pause at nominal voltage for 1.5 hours unpowered, to allow any self-heating to stabilize, before continuing.
6. Subject the EUT to overnight soak at +50°C.
7. With the EUT, powered via nominal voltage, connected to the CMW500 and in a simulated call on the centre channel, measure the carrier frequency. These measurements should be made within 2 minutes of Powering up the EUT, to prevent significant self-warming.
8. Repeat the above measurements at 10°C increments from +50°C to -30°C. Allow at least 1.5 hours at each temperature, unpowered, before making measurements
9. At all temperature levels hold the temperature to +/- 0.5°C during the measurement procedure.

Frequency Stability Under Voltage Variations:

Set chamber temperature to 20°C. Use a variable AC power supply / DC power source to power the EUT and set the voltage to rated voltage. Set the spectrum analyzer RBW low enough to obtain the desired frequency resolution and recorded the frequency.

Reduce the input voltage to specify extreme voltage variation ($\pm 15\%$) and endpoint, record the maximum frequency change.

TEST RESULTS**Remark:**

We were tested all RB Configuration refer 3GPP TS136 521 for each Channel Bandwidth of LTE FDD Band 2, LTE FDD Band 4 and LTE FDD Band 12; recorded worst case for each Channel Bandwidth of LTE FDD Band 2, LTE FDD Band 4 and LTE FDD Band 12.

LTE Band 2, QPSK, 1.4MHz bandwidth (worst case of all bandwidths)

LTE FDD Band 2					
DC Power	Temperature (°C)	Frequency error(Hz)	Frequency error(ppm)	Limit (ppm)	Verdict
5.40	20	62	0.033	±2.50	PASS
6.00	20	27	0.014	±2.50	PASS
6.60	20	37	0.020	±2.50	PASS
6.00	-30	83	0.044	±2.50	PASS
6.00	-20	51	0.027	±2.50	PASS
6.00	-10	77	0.041	±2.50	PASS
6.00	0	5	0.003	±2.50	PASS
6.00	10	45	0.024	±2.50	PASS
6.00	20	27	0.014	±2.50	PASS
6.00	30	90	0.048	±2.50	PASS
6.00	40	80	0.043	±2.50	PASS
6.00	50	20	0.011	±2.50	PASS

LTE Band 2, 16QAM, 1.4MHz bandwidth (worst case of all bandwidths)

LTE FDD Band 2					
DC Power	Temperature (°C)	Frequency error(Hz)	Frequency error(ppm)	Limit (ppm)	Verdict
5.40	20	48	0.026	±2.50	PASS
6.00	20	43	0.023	±2.50	PASS
6.60	20	18	0.010	±2.50	PASS
6.00	-30	11	0.006	±2.50	PASS
6.00	-20	73	0.039	±2.50	PASS
6.00	-10	96	0.051	±2.50	PASS
6.00	0	62	0.033	±2.50	PASS
6.00	10	9	0.005	±2.50	PASS
6.00	20	19	0.010	±2.50	PASS
6.00	30	31	0.016	±2.50	PASS
6.00	40	2	0.001	±2.50	PASS
5.40	50	36	0.019	±2.50	PASS

LTE Band 4, QPSK, 1.4MHz bandwidth (worst case of all bandwidths)

LTE FDD Band 4					
DC Power	Temperature (°C)	Frequency error(Hz)	Frequency error(ppm)	Limit (ppm)	Verdict
5.40	20	14	0.008	±2.50	PASS
6.00	20	52	0.030	±2.50	PASS
6.60	20	32	0.018	±2.50	PASS
6.00	-30	14	0.008	±2.50	PASS
6.00	-20	33	0.019	±2.50	PASS
6.00	-10	1	0.001	±2.50	PASS
6.00	0	78	0.045	±2.50	PASS
6.00	10	29	0.017	±2.50	PASS
6.00	20	0	0.000	±2.50	PASS
6.00	30	97	0.056	±2.50	PASS
6.00	40	21	0.012	±2.50	PASS
5.40	50	18	0.010	±2.50	PASS

LTE Band 4, 16QAM, 1.4MHz bandwidth (worst case of all bandwidths)

LTE FDD Band 4

DC Power	Temperature (°C)	Frequency error(Hz)	Frequency error(ppm)	Limit (ppm)	Verdict
5.40	20	28	0.016	±2.50	PASS
6.00	20	4	0.002	±2.50	PASS
6.60	20	34	0.019	±2.50	PASS
6.00	-30	10	0.006	±2.50	PASS
6.00	-20	94	0.054	±2.50	PASS
6.00	-10	74	0.042	±2.50	PASS
6.00	0	17	0.010	±2.50	PASS
6.00	10	15	0.009	±2.50	PASS
6.00	20	94	0.054	±2.50	PASS
6.00	30	4	0.002	±2.50	PASS
6.00	40	85	0.049	±2.50	PASS
5.40	50	6	0.003	±2.50	PASS

LTE Band 12, QPSK, 1.4MHz bandwidth (worst case of all bandwidths and modulation type)

LTE FDD Band 12

DC Power	Temperature (°C)	Frequency error(Hz)	Frequency error(ppm)	Limit (ppm)	Verdict
5.40	20	44	0.062	±2.50	PASS
6.00	20	33	0.047	±2.50	PASS
6.60	20	19	0.027	±2.50	PASS
6.00	-30	71	0.100	±2.50	PASS
6.00	-20	73	0.103	±2.50	PASS
6.00	-10	53	0.075	±2.50	PASS
6.00	0	70	0.099	±2.50	PASS
6.00	10	49	0.069	±2.50	PASS
6.00	20	43	0.061	±2.50	PASS
6.00	30	38	0.054	±2.50	PASS
6.00	40	15	0.021	±2.50	PASS
5.40	50	17	0.024	±2.50	PASS

LTE Band 12, 16QAM, 1.4MHz bandwidth (worst case of all bandwidths and modulation type)

LTE FDD Band 12

DC Power	Temperature (°C)	Frequency error(Hz)	Frequency error(ppm)	Limit (ppm)	Verdict
5.40	20	47	0.066	±2.50	PASS
6.00	20	91	0.129	±2.50	PASS
6.60	20	25	0.035	±2.50	PASS
6.00	-30	98	0.139	±2.50	PASS
6.00	-20	93	0.131	±2.50	PASS
6.00	-10	69	0.098	±2.50	PASS
6.00	0	12	0.017	±2.50	PASS
6.00	10	60	0.085	±2.50	PASS
6.00	20	6	0.008	±2.50	PASS
6.00	30	15	0.021	±2.50	PASS
6.00	40	85	0.120	±2.50	PASS
5.40	50	68	0.096	±2.50	PASS

5 Test Setup Photos of the EUT

Pleaserefer to separated files for Test Setup Photos of the EUT.

6 External Photos of the EUT

Pleaserefer to separated files for External Photos of the EUT.

7 Internal Photos of the EUT

Pleaserefer to separated files for Internal Photos of the EUT.

*******End of Report*******