

Test Report

Applicant: Habitat Technologies LLC.

Address of Applicant: 330 East 38th Street, Suite 530, New York 10016, United States

Manufacturer/Factory: COMPUTIME ELECTRONICS (SHENZHEN) CO., LTD.

Address of Manufacturer/Factory: Computime Technology Pk, Dan Zhu Tou Cun Buji, Longgang Region Shenzhen China

Equipment Under Test (EUT)

Product Name: PTAC Base Control Module

Model No.: SAUPTR1, HTM-01

FCC ID: 2AUYL-HTM01

IC: 25666-HTM01

Applicable standards: FCC CFR Title 47 Part 15 Subpart C Section 15.247
RSS-247 Issue 2: February 2017
RSS-Gen Issue 5: March 2019

Date of sample receipt: November 01, 2019

Date of Test: November 01-06, 2019

Date of report issued: November 06, 2019

Test Result : PASS *

* In the configuration tested, the EUT complied with the standards specified above.

Authorized Signature:



Robinson Lo
Laboratory Manager

This results shown in this test report refer only to the sample(s) tested, this test report cannot be reproduced, except in full, without prior written permission of the company. The report would be invalid without specific stamp of test institute and the signatures of compiler and approver.

2 Version

Version No.	Date	Description
00	November 06, 2019	Original

Prepared By:



Date:

November 06, 2019

Project Engineer

Check By:



Date:

November 06, 2019

Reviewer

3 Contents

	Page
1 COVER PAGE.....	1
2 VERSION.....	2
3 CONTENTS	3
4 TEST SUMMARY	4
4.1 MEASUREMENT UNCERTAINTY	4
5 GENERAL INFORMATION.....	5
5.1 GENERAL DESCRIPTION OF EUT	5
5.2 TEST MODE	6
5.3 DESCRIPTION OF SUPPORT UNITS	6
5.4 DEVIATION FROM STANDARDS.....	6
5.5 ABNORMALITIES FROM STANDARD CONDITIONS	6
5.6 TEST FACILITY.....	6
5.7 TEST LOCATION	6
5.8 ADDITIONAL INSTRUCTIONS.....	6
6 TEST INSTRUMENTS LIST	7
7 TEST RESULTS AND MEASUREMENT DATA.....	9
7.1 ANTENNA REQUIREMENT	9
7.2 CONDUCTED EMISSIONS	10
7.3 CONDUCTED OUTPUT POWER	13
7.4 CHANNEL BANDWIDTH & 99% OCCUPY BANDWIDTH.....	14
7.5 POWER SPECTRAL DENSITY	16
7.6 BAND EDGES.....	17
7.6.1 Conducted Emission Method.....	17
7.7 SPURIOUS EMISSION.....	18
7.7.1 Conducted Emission Method.....	18
7.7.2 Radiated Emission Method.....	20
7.8 FREQUENCY STABILITY	27
8 TEST SETUP PHOTO	29
9 EUT CONSTRUCTIONAL DETAILS	29

4 Test Summary

Test Item	Section in CFR 47	Result
Antenna requirement	FCC part 15.203/15.247 (c) RSS-Gen Section 6.8	Pass
AC Power Line Conducted Emission	FCC part 15.207 RSS-Gen Section 8.8	Pass
Conducted Peak Output Power	FCC part 15.247 (b)(3) RSS-247 Section 5.4(d)	Pass
Channel Bandwidth & 99% OCB	FCC part 15.247 (a)(2) RSS-247 Section 5.2(a) & 6.7	Pass
Power Spectral Density	FCC part 15.247 (e) RSS-247 Section 5.2(b)	Pass
Band Edge	FCC part 15.247(d) RSS-247 Section 5.5	Pass
Spurious Emission	FCC part 15.205/15.209 RSS-Gen Section 3.3 & 8.9 & 8.10	Pass
Frequency stability	RSS-Gen Section 6.11& Section 8.11	Pass

Pass: The EUT complies with the essential requirements in the standard.

Remark : Test according to ANSI C63.10:2013

4.1 Measurement Uncertainty

Test Item	Frequency Range	Measurement Uncertainty	Notes
Radiated Emission	30MHz-200MHz	3.8039dB	(1)
Radiated Emission	200MHz-1GHz	3.9679dB	(1)
Radiated Emission	1GHz-18GHz	4.29dB	(1)
Radiated Emission	18GHz-40GHz	3.30dB	(1)
AC Power Line Conducted Emission	0.15MHz ~ 30MHz	3.44dB	(1)
RF conducted power measurement	30M~26.5G	0.65dB	(1)
Conducted Emission	30M~26.5G	2.8dB	(1)
PSD measurement	30M~26.5G	1.31dB	(1)

Note (1): The measurement uncertainty is for coverage factor of k=2 and a level of confidence of 95%.

5 General Information

5.1 General Description of EUT

Product Name:	PTAC Base Control Module
Model No.:	SAUPTR1, HTM-01
Test Model No:	SAUPTR1
Remark: All above models are identical in the same PCB layout, interior structure and electrical circuits. The differences are color and model name for commercial purpose.	
Test sample(s) ID:	GTS201911000002-1
Sample(s) Status:	Engineer sample
Serial No.:	SAUPTR1: 001E5E0902569820
Hardware Version:	SBR-001
Software Version:	SBR-001
Operation Frequency:	915MHz
Channel Numbers:	1
Modulation Type:	OQPSK
Antenna Type:	Internal Antenna
Antenna Gain:	0dBi(Declare by applicant)
Power Supply:	AC 24V

5.2 Test mode

Transmitting mode	Keep the EUT in continuously transmitting mode
<p><i>Remark: During the test, the test voltage was tuned from 85% to 115% of the nominal rated supply voltage, and found that the worst case was under the nominal rated supply condition. So the report just shows that condition's data.</i></p>	

5.3 Description of Support Units

Manufacturer	Description	Model	Serial Number
Computime	AC/AC POWER SUPPLY	KJS-66	N/A
Computime	PTAC Thermostat	SAUPTT1	N/A

5.4 Deviation from Standards

None.

5.5 Abnormalities from Standard Conditions

None.

5.6 Test Facility

<p>The test facility is recognized, certified, or accredited by the following organizations:</p> <ul style="list-style-type: none"> ● FCC —Registration No.: 381383 Global United Technology Services Co., Ltd., Shenzhen EMC Laboratory has been registered and fully described in a report filed with the (FCC) Federal Communications Commission. The acceptance letter from the FCC is maintained in files. Registration 381383. ● IC —Registration No.: 9079A The 3m Semi-anechoic chamber of Global United Technology Services Co., Ltd. has been registered by Certification and Engineering Bureau of Industry Canada for radio equipment testing with Registration No.: 9079A ● NVLAP (LAB CODE:600179-0) Global United Technology Services Co., Ltd., is accredited by the National Voluntary Laboratory Accreditation Program (NVLAP). LAB CODE:600179-0

5.7 Test Location

All tests were performed at:
<p>Global United Technology Services Co., Ltd. Address: No. 123-128, Tower A, Jinyuan Business Building, No.2, Laodong Industrial Zone, Xixiang Road, Baoan District, Shenzhen, Guangdong, China 518102 Tel: 0755-27798480 Fax: 0755-27798960</p>

5.8 Additional instructions

Software (Used for test) from client

Special test software was pre-built-in by manufacturer, power set default, test software version V1.0

6 Test Instruments list

Radiated Emission:						
Item	Test Equipment	Manufacturer	Model No.	Inventory No.	Cal.Date (mm-dd-yy)	Cal.Due date (mm-dd-yy)
1	3m Semi- Anechoic Chamber	ZhongYu Electron	9.2(L)*6.2(W)* 6.4(H)	GTS250	July. 03 2015	July. 02 2020
2	Control Room	ZhongYu Electron	6.2(L)*2.5(W)* 2.4(H)	GTS251	N/A	N/A
3	EMI Test Receiver	Rohde & Schwarz	ESU26	GTS203	June. 26 2019	June. 25 2020
4	BiConiLog Antenna	SCHWARZBECK MESS-ELEKTRONIK	VULB9163	GTS214	June. 26 2019	June. 25 2020
5	Double -ridged waveguide horn	SCHWARZBECK MESS-ELEKTRONIK	BBHA 9120 D	GTS208	June. 26 2019	June. 25 2020
6	Horn Antenna	ETS-LINDGREN	3160	GTS217	June. 26 2019	June. 25 2020
7	EMI Test Software	AUDIX	E3	N/A	N/A	N/A
8	Coaxial Cable	GTS	N/A	GTS213	June. 26 2019	June. 25 2020
9	Coaxial Cable	GTS	N/A	GTS211	June. 26 2019	June. 25 2020
10	Coaxial cable	GTS	N/A	GTS210	June. 26 2019	June. 25 2020
11	Coaxial Cable	GTS	N/A	GTS212	June. 26 2019	June. 25 2020
12	Amplifier(100kHz-3GHz)	HP	8347A	GTS204	June. 26 2019	June. 25 2020
13	Amplifier(2GHz-20GHz)	HP	84722A	GTS206	June. 26 2019	June. 25 2020
14	Amplifier (18-26GHz)	Rohde & Schwarz	AFS33-18002 650-30-8P-44	GTS218	June. 26 2019	June. 25 2020
15	Band filter	Amindeon	82346	GTS219	June. 26 2019	June. 25 2020
16	Power Meter	Anritsu	ML2495A	GTS540	June. 26 2019	June. 25 2020
17	Power Sensor	Anritsu	MA2411B	GTS541	June. 26 2019	June. 25 2020
18	Wideband Radio Communication Tester	Rohde & Schwarz	CMW500	GTS575	June. 26 2019	June. 25 2020
19	Splitter	Agilent	11636B	GTS237	June. 26 2019	June. 25 2020
20	Loop Antenna	ZHINAN	ZN30900A	GTS534	June. 26 2019	June. 25 2020
21	Breitband hornantenne	SCHWARZBECK	BBHA 9170	GTS579	Oct. 19 2019	Oct. 18 2020
22	Amplifier	TDK	PA-02-02	GTS574	Oct. 19 2019	Oct. 18 2020
23	Amplifier	TDK	PA-02-03	GTS576	Oct. 19 2019	Oct. 18 2020
24	PSA Series Spectrum Analyzer	Rohde & Schwarz	FSP	GTS578	June. 26 2019	June. 25 2020

Conducted Emission						
Item	Test Equipment	Manufacturer	Model No.	Inventory No.	Cal.Date (mm-dd-yy)	Cal.Due date (mm-dd-yy)
1	Shielding Room	ZhongYu Electron	7.3(L)x3.1(W)x2.9(H)	GTS252	May.15 2019	May.14 2022
2	EMI Test Receiver	R&S	ESCI 7	GTS552	June. 26 2019	June. 25 2020
3	Coaxial Switch	ANRITSU CORP	MP59B	GTS225	June. 26 2019	June. 25 2020
4	ENV216 2-L-V-NETZNACHB.DE	ROHDE&SCHWARZ	ENV216	GTS226	June. 26 2019	June. 25 2020
5	Coaxial Cable	GTS	N/A	GTS227	N/A	N/A
6	EMI Test Software	AUDIX	E3	N/A	N/A	N/A
7	Thermo meter	KTJ	TA328	GTS233	June. 26 2019	June. 25 2020
8	Absorbing clamp	Elektronik-Feinmechanik	MDS21	GTS229	June. 26 2019	June. 25 2020
9	ISN	SCHWARZBECK	NTFM 8158	GTD565	June. 26 2019	June. 25 2020

RF Conducted Test:						
Item	Test Equipment	Manufacturer	Model No.	Serial No.	Cal.Date (mm-dd-yy)	Cal.Due date (mm-dd-yy)
1	MXA Signal Analyzer	Agilent	N9020A	GTS566	June. 26 2019	June. 25 2020
2	EMI Test Receiver	R&S	ESCI 7	GTS552	June. 26 2019	June. 25 2020
3	Spectrum Analyzer	Agilent	E4440A	GTS533	June. 26 2019	June. 25 2020
4	MXG vector Signal Generator	Agilent	N5182A	GTS567	June. 26 2019	June. 25 2020
5	ESG Analog Signal Generator	Agilent	E4428C	GTS568	June. 26 2019	June. 25 2020
6	USB RF Power Sensor	DARE	RPR3006W	GTS569	June. 26 2019	June. 25 2020
7	RF Switch Box	Shongyi	RFSW3003328	GTS571	June. 26 2019	June. 25 2020
8	Programmable Constant Temp & Humi Test Chamber	WEWON	WHTH-150L-40-880	GTS572	June. 26 2019	June. 25 2020

General used equipment:						
Item	Test Equipment	Manufacturer	Model No.	Inventory No.	Cal.Date (mm-dd-yy)	Cal.Due date (mm-dd-yy)
1	Humidity/ Temperature Indicator	KTJ	TA328	GTS243	June. 26 2019	June. 25 2020
2	Barometer	ChangChun	DYM3	GTS255	June. 26 2019	June. 25 2020

7 Test results and Measurement Data

7.1 Antenna requirement

Standard requirement:	FCC Part15 C Section 15.203 /247(c)
<p>FCC Part 15.203 requirement:</p> <p>An intentional radiator shall be designed to ensure that no antenna other than that furnished by the responsible party shall be used with the device. The use of a permanently attached antenna or of an antenna that uses a unique coupling to the intentional radiator, the manufacturer may design the unit so that a broken antenna can be replaced by the user, but the use of a standard antenna jack or electrical connector is prohibited.</p> <p>15.247(c) (1)(i) requirement:</p> <p>(i) Systems operating in the 2400-2483.5 MHz band that is used exclusively for fixed. Point-to-point operations may employ transmitting antennas with directional gain greater than 6dBi provided the maximum conducted output power of the intentional radiator is reduced by 1 dB for every 3 dB that the directional gain of the antenna exceeds 6dBi.</p>	
<p>RSS-Gen 6.8</p> <p>A transmitter can only be sold or operated with antennas with which it was approved. When a measurement at the antenna connector is used to determine RF output power, the effective gain of the device's antenna shall be stated, based on measurement or on data from the antenna manufacturer. For transmitters of RF output power of 10 milliwatts or less, only the portion of the antenna gain that is in excess of 6 dBi (6 dB above isotropic gain) shall be added to the measured RF output power to demonstrate compliance with the radiated power limits specified in the applicable standard. For transmitters of output power greater than 10 milliwatts, the total antenna gain shall be added to the measured RF output power to demonstrate compliance to the specified radiated power</p>	
<p>E.U.T Antenna:</p> <p><i>The antenna is internal antenna, the best case gain of the antenna is 0dBi, reference to the appendix II for details.</i></p>	

7.2 Conducted Emissions

Test Requirement:	FCC Part15 C Section 15.207 RSS-Gen Section 8.8				
Test Method:	ANSI C63.10:2013 and RSS-Gen				
Test Frequency Range:	150KHz to 30MHz				
Class / Severity:	Class B				
Receiver setup:	RBW=9KHz, VBW=30KHz, Sweep time=auto				
Limit:	Frequency range (MHz)		Limit (dBuV)		
			Quasi-peak	Average	
	0.15-0.5		66 to 56*	56 to 46*	
	0.5-5		56	46	
5-30		60	50		
* Decreases with the logarithm of the frequency.					
Test setup:	<p><i>Remark</i> E.U.T: Equipment Under Test LISN: Line Impedance Stabilization Network Test table height=0.8m</p>				
Test procedure:	<ol style="list-style-type: none"> 1. The E.U.T and simulators are connected to the main power through a line impedance stabilization network (L.I.S.N.). This provides a 50ohm/50uH coupling impedance for the measuring equipment. 2. The peripheral devices are also connected to the main power through a LISN that provides a 50ohm/50uH coupling impedance with 50ohm termination. (Please refer to the block diagram of the test setup and photographs). 3. Both sides of A.C. line are checked for maximum conducted interference. In order to find the maximum emission, the relative positions of equipment and all of the interface cables must be changed according to ANSI C63.10:2009 on conducted measurement. 				
Test Instruments:	Refer to section 6.0 for details				
Test mode:	Refer to section 5.2 for details				
Test environment:	Temp.:	25 °C	Humid.:	52%	Press.: 1012mbar
Test results:	Pass				

Measurement data

Line:

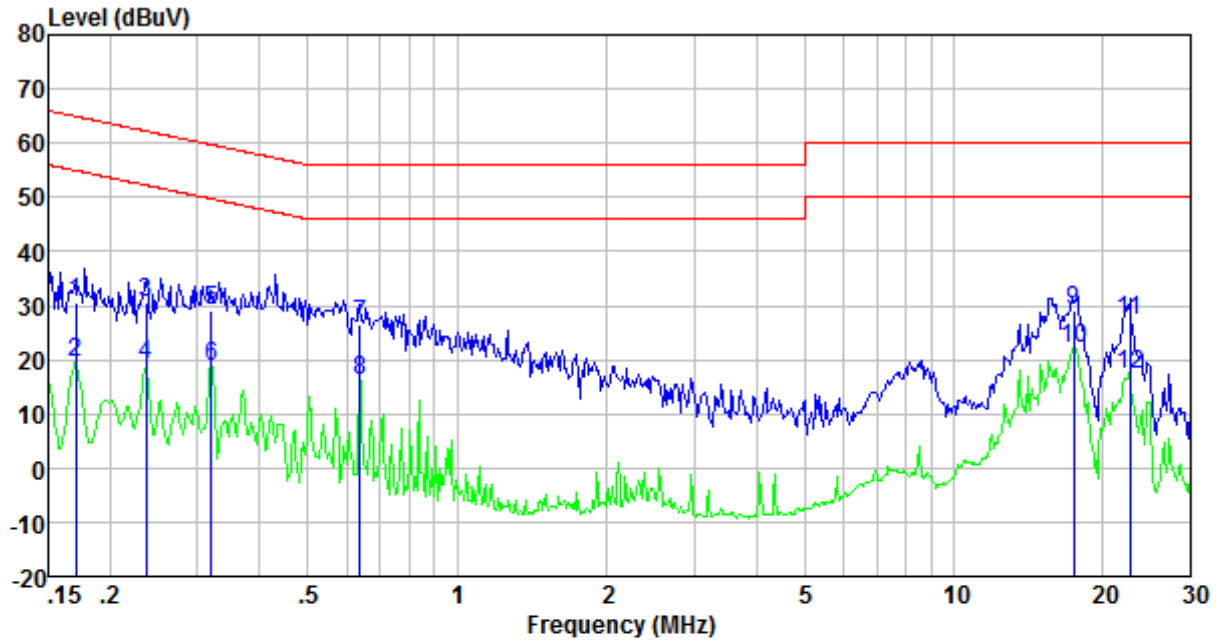

Freq. MHz	Read Level dBuV	Factor dB/m	Level dBuV	Limit Line dBuV	Over Limit dB	Remark
0.17	30.00	0.49	30.49	64.94	-34.45	QP
0.17	18.82	0.49	19.31	54.94	-35.63	Average
0.24	29.88	0.51	30.39	62.22	-31.83	QP
0.24	18.79	0.51	19.30	52.22	-32.92	Average
0.32	28.62	0.49	29.11	59.71	-30.60	QP
0.32	18.11	0.49	18.60	49.71	-31.11	Average
0.64	26.11	0.40	26.51	56.00	-29.49	QP
0.64	15.69	0.40	16.09	46.00	-29.91	Average
17.47	28.45	0.47	28.92	60.00	-31.08	QP
17.47	21.67	0.47	22.14	50.00	-27.86	Average
22.66	26.61	0.56	27.17	60.00	-32.83	QP
22.66	16.64	0.56	17.20	50.00	-32.80	Average

Neutral:

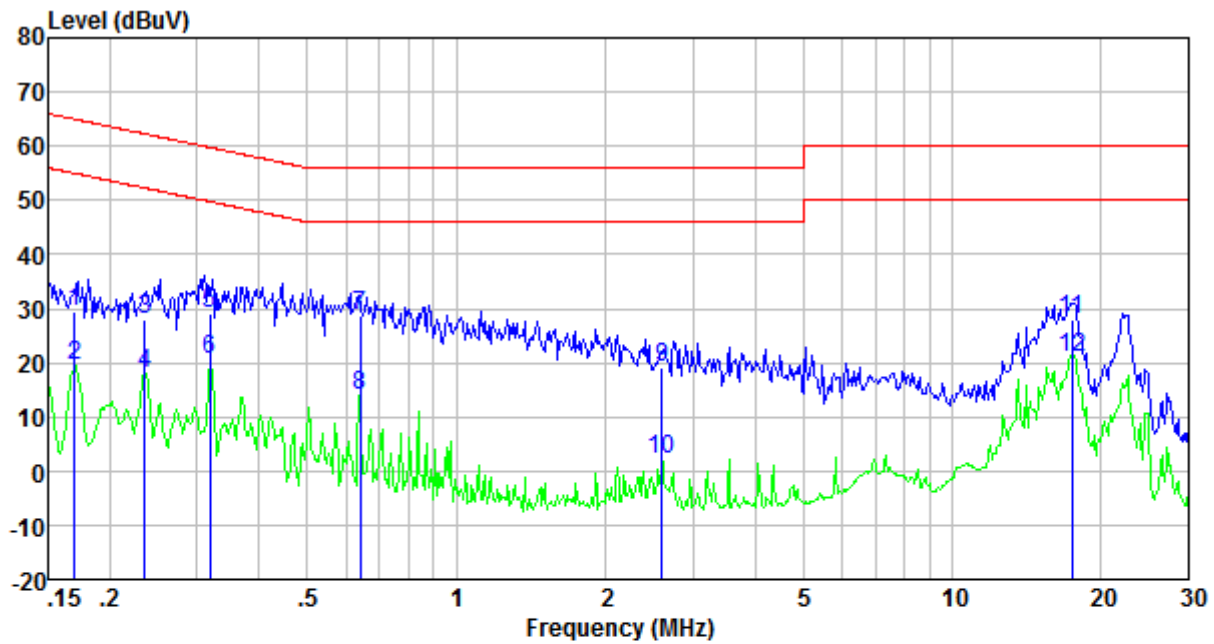

Freq. MHz	Read Level dBuV	Factor dB/m	Level dBuV	Limit Line dBuV	Over Limit dB	Remark
0.17	28.99	0.49	29.48	64.99	-35.51	QP
0.17	18.85	0.49	19.34	54.99	-35.65	Average
0.24	27.61	0.51	28.12	62.26	-34.14	QP
0.24	17.67	0.51	18.18	52.26	-34.08	Average
0.32	28.68	0.49	29.17	59.75	-30.58	QP
0.32	20.01	0.49	20.50	49.75	-29.25	Average
0.64	28.31	0.39	28.70	56.00	-27.30	QP
0.64	13.74	0.39	14.13	46.00	-31.87	Average
2.59	18.82	0.38	19.20	56.00	-36.80	QP
2.59	1.94	0.38	2.32	46.00	-43.68	Average
17.47	27.55	0.47	28.02	60.00	-31.98	QP
17.47	20.66	0.47	21.13	50.00	-28.87	Average

Notes:

1. An initial pre-scan was performed on the line and neutral lines with peak detector.
2. Quasi-Peak and Average measurement were performed at the frequencies with maximized peak emission.
3. Final Level = Receiver Read level + LISN Factor + Cable Loss
4. If the average limit is met when using a quasi-peak detector receiver, the EUT shall be deemed to meet both limits and measurement with the average detector receiver is unnecessary.

7.3 Conducted Output Power

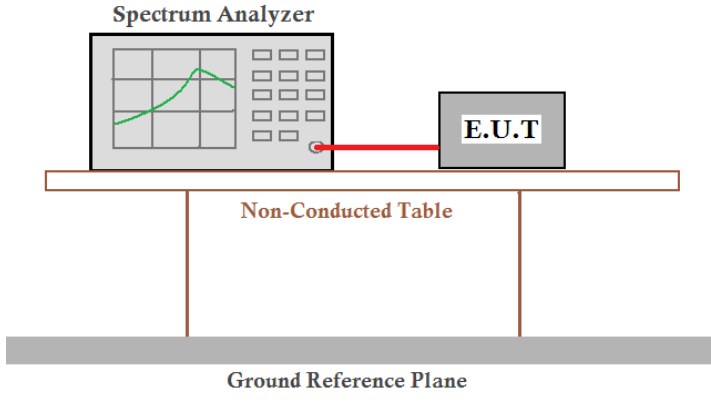
Test Requirement:	FCC Part15 C Section 15.247 (b)(3) RSS-247 Section 5.4(d)
Test Method:	ANSI C63.10:2013 and KDB558074 D01 DTS Meas Guidance V05r02
Limit:	30dBm (36dBm EIRP for IC limit)
Test setup:	 <p>The diagram illustrates the test setup. A Spectrum Analyzer is connected via a red cable to an E.U.T. (Equipment Under Test). Both are placed on a Non-Conducted Table. Below the table is a Ground Reference Plane.</p>
Test Instruments:	Refer to section 6.0 for details
Test mode:	Refer to section 5.2 for details
Test results:	Pass

Measurement Data

Test Frequency	Peak Output Power (dBm)	Limit(dBm)	Result
915MHz	15.41	Refer to above	Pass

Test plot as follows:

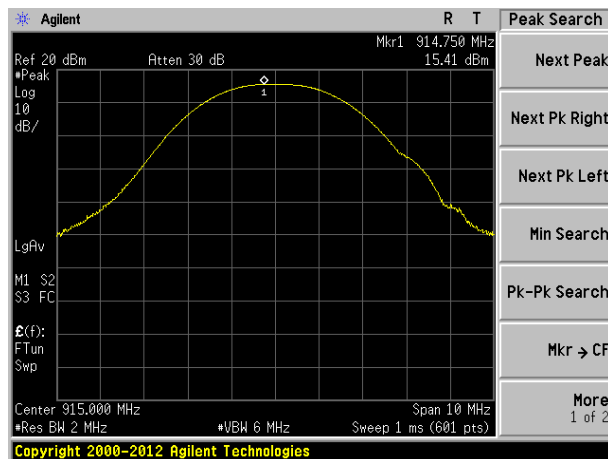

7.4 Channel Bandwidth & 99% Occupancy Bandwidth

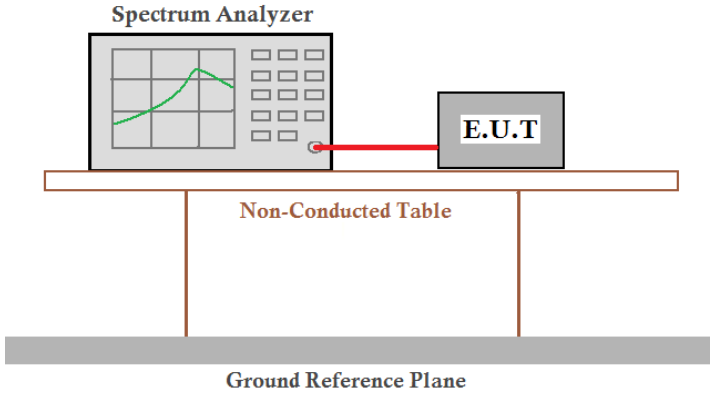
Test Requirement:	FCC Part15 C Section 15.247 (a)(2) RSS-Gen Section 6.6 & RSS-247 Section 5.2(a)
Test Method:	ANSI C63.10:2013 and KDB558074 D01 DTS Meas Guidance V05r02
Limit:	>500KHz
Test setup:	 <p>The diagram illustrates the test setup. A Spectrum Analyzer is connected to an E.U.T. (Equipment Under Test) via a red cable. Both are placed on a Non-Conducted Table, which is supported by a Ground Reference Plane.</p>
Test Instruments:	Refer to section 6.0 for details
Test mode:	Refer to section 5.2 for details
Test results:	Pass

Measurement Data

Test Frequency	-6dB Channel Bandwidth (MHz)	Limit(KHz)	Result
915MHz	0.643	>500	Pass

Test Frequency	99% Bandwidth (MHz)	Result
915MHz	1.0004	Pass

Test plot as follows:

FCC

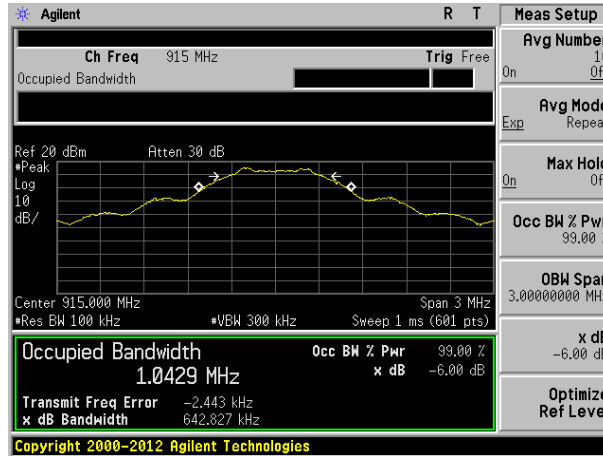

IC

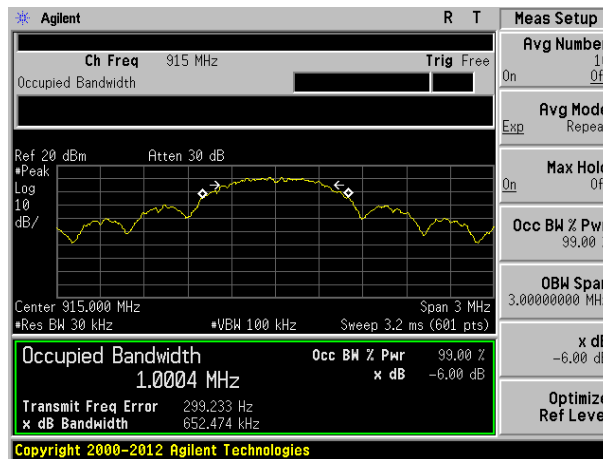

7.5 Power Spectral Density

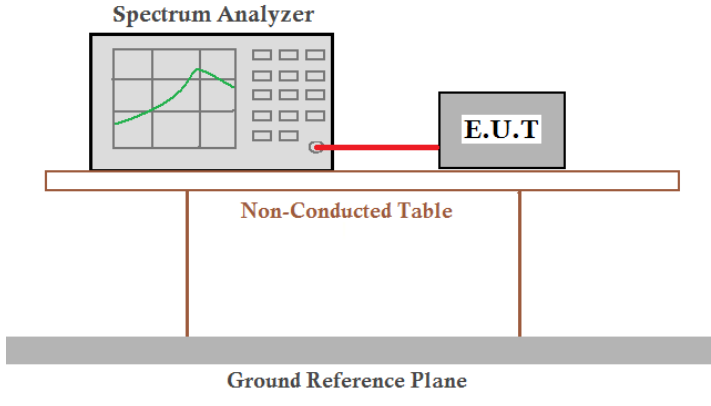
Test Requirement:	FCC Part15 C Section 15.247 (e) RSS-247 Section 5.2(b)
Test Method:	ANSI C63.10:2013 and KDB558074 D01 DTS Meas Guidance V05r02
Limit:	8dBm/3kHz
Test setup:	 <p>The diagram illustrates the test setup. A Spectrum Analyzer is connected via a red cable to an E.U.T. (Equipment Under Test). Both are placed on a Non-Conducted Table. Below the table is a Ground Reference Plane.</p>
Test Instruments:	Refer to section 6.0 for details
Test mode:	Refer to section 5.2 for details
Test results:	Pass

Measurement Data

Test Frequency	Power Spectral Density (dBm/3kHz)	Limit(dBm/3kHz)	Result
915MHz	3.21	8.00	Pass

Test plot as follows:

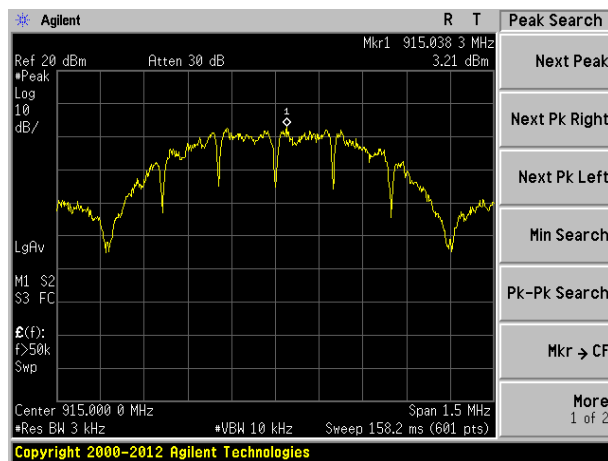

7.6 Band edges

7.6.1 Conducted Emission Method

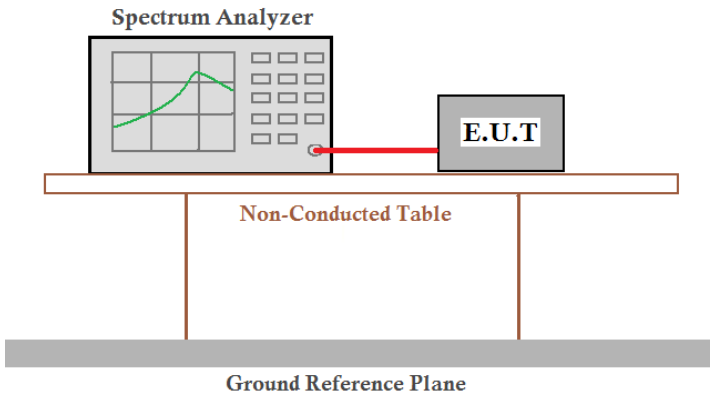
Test Requirement:	FCC Part15 C Section 15.247 (d) RSS-247 Section 5.5
Test Method:	ANSI C63.10:2013 and KDB558074 D01 DTS Meas Guidance V05r02
Limit:	In any 100 kHz bandwidth outside the frequency band in which the spread spectrum intentional radiator is operating, the radio frequency power that is produced by the intentional radiator shall be at least 20 dB below that in the 100 kHz bandwidth within the band that contains the highest level of the desired power, based on either an RF conducted or a radiated measurement.
Test setup:	 <p>The diagram illustrates the test setup. A Spectrum Analyzer is connected via a red cable to an Equipment Under Test (E.U.T.). Both are placed on a Non-Conducted Table. This table is supported by two vertical legs and sits on a Ground Reference Plane, which is represented by a grey shaded area at the bottom.</p>
Test Instruments:	Refer to section 6.0 for details
Test mode:	Refer to section 5.2 for details
Test results:	Pass

Test plot as follows:

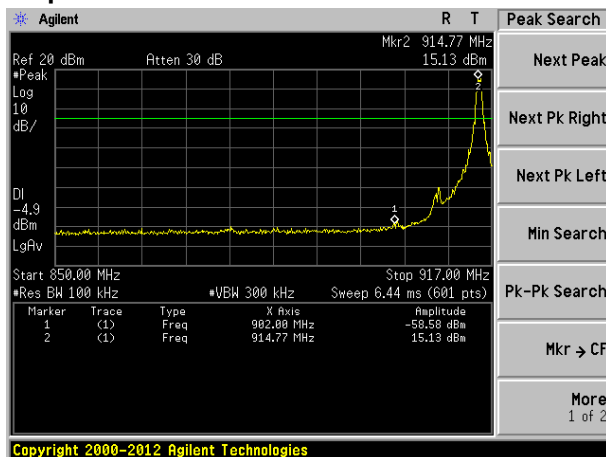

Lowest channel

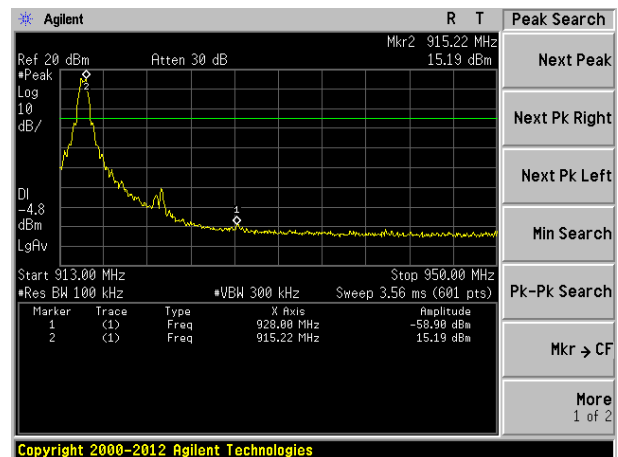

Highest channel

7.7 Spurious Emission

7.7.1 Conducted Emission Method

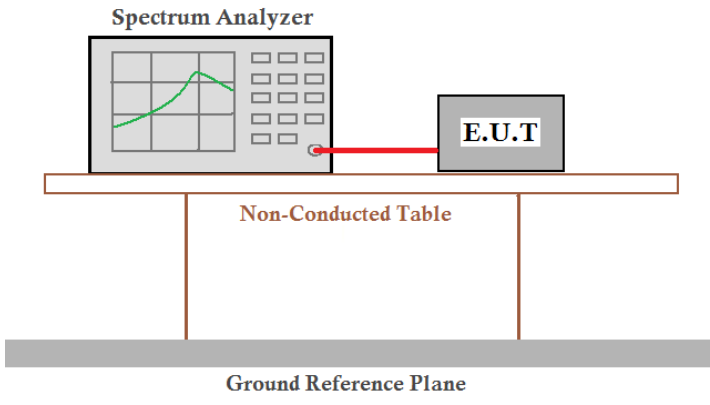
Test Requirement:	FCC Part15 C Section 15.247 (d) RSS-247 Section 5.5
Test Method:	ANSI C63.10:2013 and KDB558074 D01 DTS Meas Guidance V05r02
Limit:	In any 100 kHz bandwidth outside the frequency band in which the spread spectrum intentional radiator is operating, the radio frequency power that is produced by the intentional radiator shall be at least 20 dB below that in the 100 kHz bandwidth within the band that contains the highest level of the desired power, based on either an RF conducted or a radiated measurement.
Test setup:	 <p>The diagram illustrates the test setup. A Spectrum Analyzer is connected to an E.U.T. (Equipment Under Test) via a red cable. Both are placed on a Non-Conducted Table, which is supported by a Ground Reference Plane.</p>
Test Instruments:	Refer to section 6.0 for details
Test mode:	Refer to section 5.2 for details
Test results:	Pass

Test plot as follows:

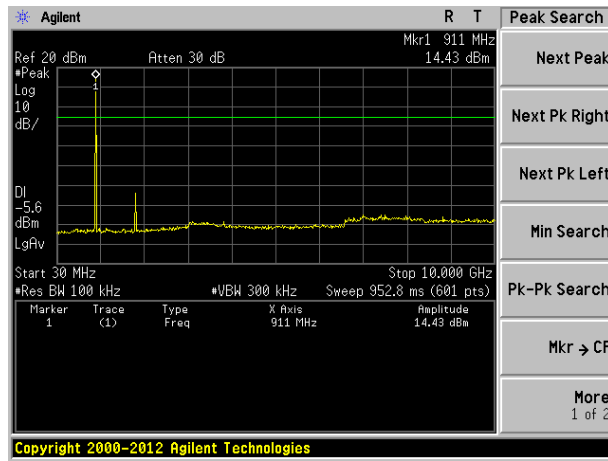

30MHz~10GHz

7.7.2 Radiated Emission Method

Test Requirement:	FCC Part15 C Section 15.209 Section 3.3 & RSS-Gen Section 8.9				
Test Method:	ANSI C63.10:2013 & RSS-Gen				
Test Frequency Range:	9kHz to 25GHz				
Test site:	Measurement Distance: 3m				
Receiver setup:	Frequency	Detector	RBW	VBW	Value
	9KHz-150KHz	Quasi-peak	200Hz	600Hz	Quasi-peak
	150KHz-30MHz	Quasi-peak	9KHz	30KHz	Quasi-peak
	30MHz-1GHz	Quasi-peak	120KHz	300KHz	Quasi-peak
	Above 1GHz	Peak	1MHz	3MHz	Peak
Peak		1MHz	10Hz	Average	
Limit:	Frequency	Limit (uV/m)	Value	Measurement Distance	
	0.009MHz-0.490MHz	2400/F(KHz)	QP	300m	
	0.490MHz-1.705MHz	24000/F(KHz)	QP	30m	
	1.705MHz-30MHz	30	QP	30m	
	30MHz-88MHz	100	QP	3m	
	88MHz-216MHz	150	QP		
	216MHz-960MHz	200	QP		
	960MHz-1GHz	500	QP		
	Above 1GHz	500	Average		
		5000	Peak		
Test setup:	For radiated emissions from 9kHz to 30MHz				

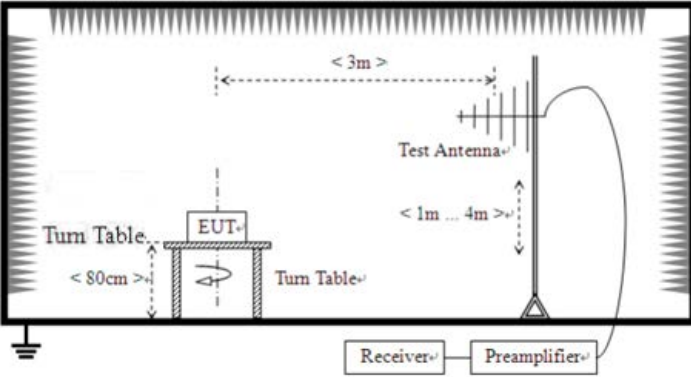
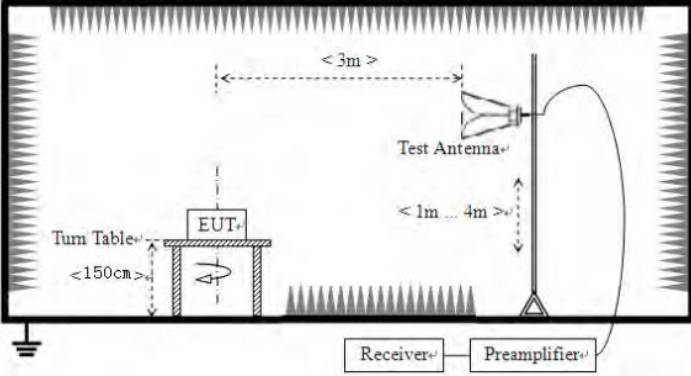
	<p>For radiated emissions from 30MHz to 1GHz</p>  <p>For radiated emissions above 1GHz</p> 
<p>Test Procedure:</p>	<ol style="list-style-type: none"> 1. The EUT was placed on the top of a rotating table (0.8m for below 1G and 1.5m for above 1G) above the ground at a 3 meter camber. The table was rotated 360 degrees to determine the position of the highest radiation. 2. The EUT was set 3 meters away from the interference-receiving antenna, which was mounted on the top of a variable-height antenna tower. 3. The antenna height is varied from one meter to four meters above the ground to determine the maximum value of the field strength. Both horizontal and vertical polarizations of the antenna are set to make the measurement. 4. For each suspected emission, the EUT was arranged to its worst case and then the antenna was tuned to heights from 1 meter to 4 meters and the rota table was turned from 0 degrees to 360 degrees to find the maximum reading. 5. The test-receiver system was set to Peak Detect Function and Specified Bandwidth with Maximum Hold Mode. 6. If the emission level of the EUT in peak mode was 10dB lower than the limit specified, then testing could be stopped and the peak values of the EUT would be reported. Otherwise the emissions that did not have 10dB margin would be re-tested one by one using peak, quasi-peak or average method as specified and then reported in a data sheet.

Test Instruments:	Refer to section 6.0 for details					
Test mode:	Refer to section 5.2 for details					
Test environment:	Temp.:	25 °C	Humid.:	52%	Press.:	1012mbar
Test results:	Pass					

Measurement data:*Remark:*

Pre-scan all kind of the place mode (X-axis, Y-axis, Z-axis), and found the Y-axis which it is worse case.

■ 9kHz~30MHz

The low frequency, which started from 9 kHz to 30 MHz, was pre-scanned and the result which was 20 dB lower than the limit line per 15.31(o) was not reported.

■ Below 1GHz

Horizontal:

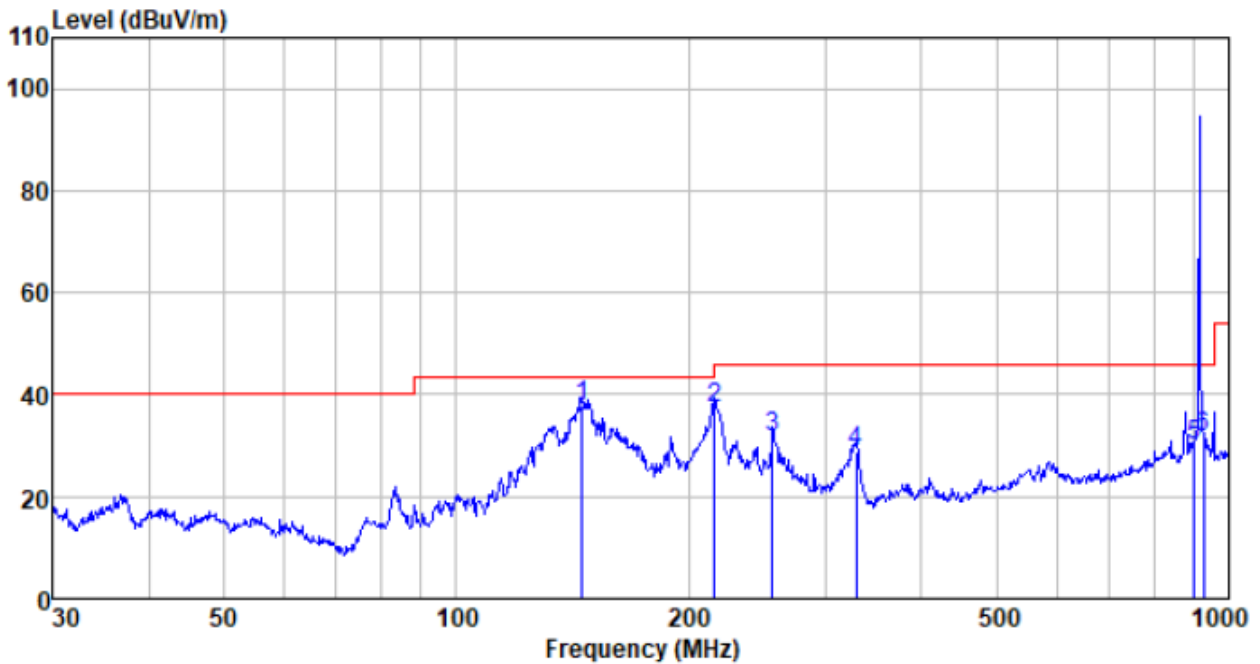

Freq MHz	Reading level dBuV	Antenna factor dB/m	Cable loss dB	Preamp factor dB	level dBuV	Limit level dBuV/m	Over limit dB	Remark
145.351	65.57	7.51	1.54	37.05	37.57	43.50	-5.93	QP
216.024	61.63	11.02	1.93	37.35	37.23	46.00	-8.77	QP
256.521	54.71	12.36	2.16	37.39	31.84	46.00	-14.16	QP
329.039	49.65	14.15	2.52	37.45	28.87	46.00	-17.13	QP
902.000	40.62	22.30	4.87	37.60	30.19	46.00	-15.81	QP
928.000	41.98	22.41	4.96	37.57	31.78	46.00	-14.22	QP

Vertical:

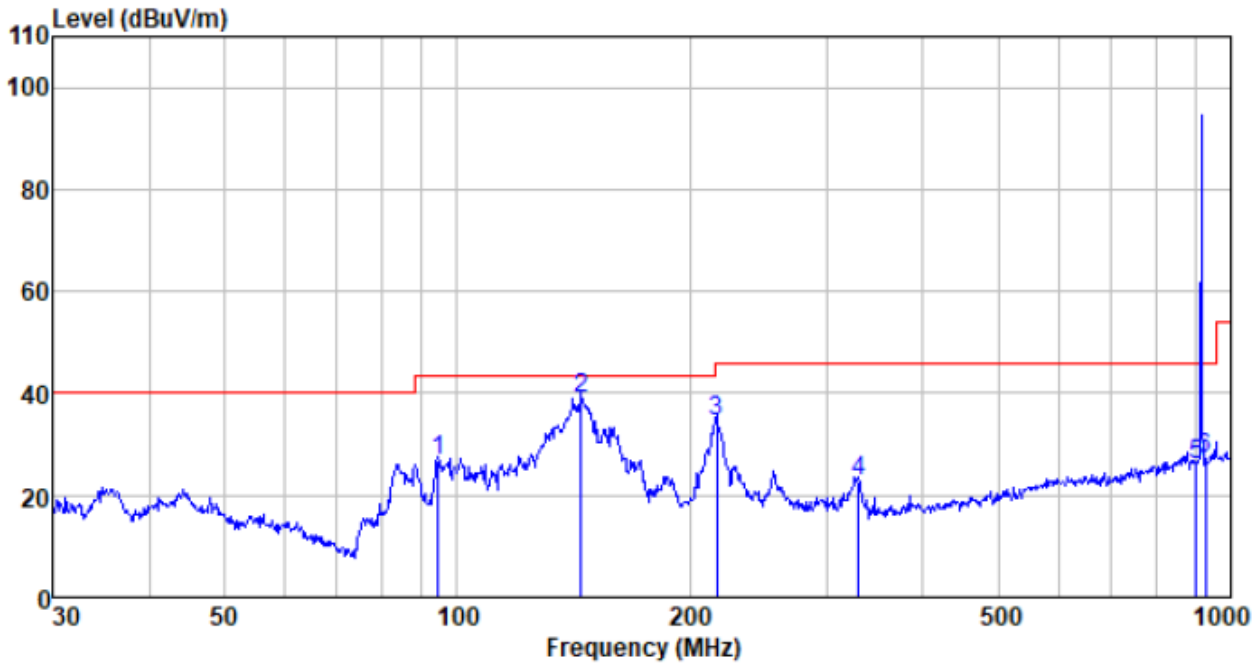

Freq MHz	Reading level dBuV	Antenna factor dB/m	Cable loss dB	Preamp factor dB	level dBuV	Limit level dBuV/m	Over limit dB	Remark
94.428	50.81	11.38	1.15	36.68	26.66	43.50	-16.84	QP
144.842	67.19	7.50	1.53	37.05	39.17	43.50	-4.33	QP
216.783	58.98	11.02	1.94	37.35	34.59	46.00	-11.41	QP
330.195	43.42	14.18	2.52	37.45	22.67	46.00	-23.33	QP
902.000	36.58	22.30	4.87	37.60	26.15	46.00	-19.85	QP
928.000	37.27	22.41	4.96	37.57	27.07	46.00	-18.93	QP

■ Above 1GHz

Horizontal:

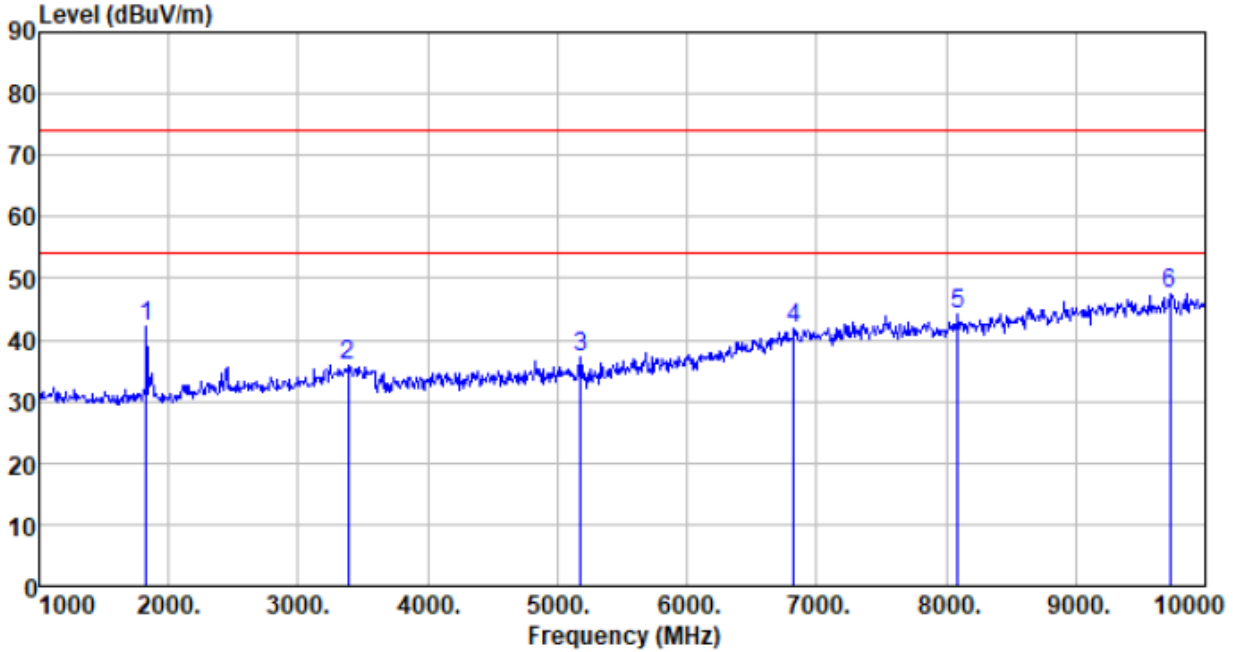

Freq MHz	Reading level dBuV	Antenna factor dB/m	Cable loss dB	Preamp factor dB	level dBuV	Limit level dBuV/m	Over limit dB	Remark
1828.000	48.15	25.85	4.87	36.54	42.33	74.00	-31.67	Peak
3385.000	38.07	28.40	6.74	37.44	35.77	74.00	-38.23	Peak
5176.000	33.88	31.57	9.03	37.39	37.09	74.00	-36.91	Peak
6823.000	30.96	35.23	11.30	35.58	41.91	74.00	-32.09	Peak
8092.000	29.93	37.38	12.24	35.48	44.07	74.00	-29.93	Peak
9730.000	30.14	38.07	14.23	35.07	47.37	74.00	-26.63	Peak

Vertical:

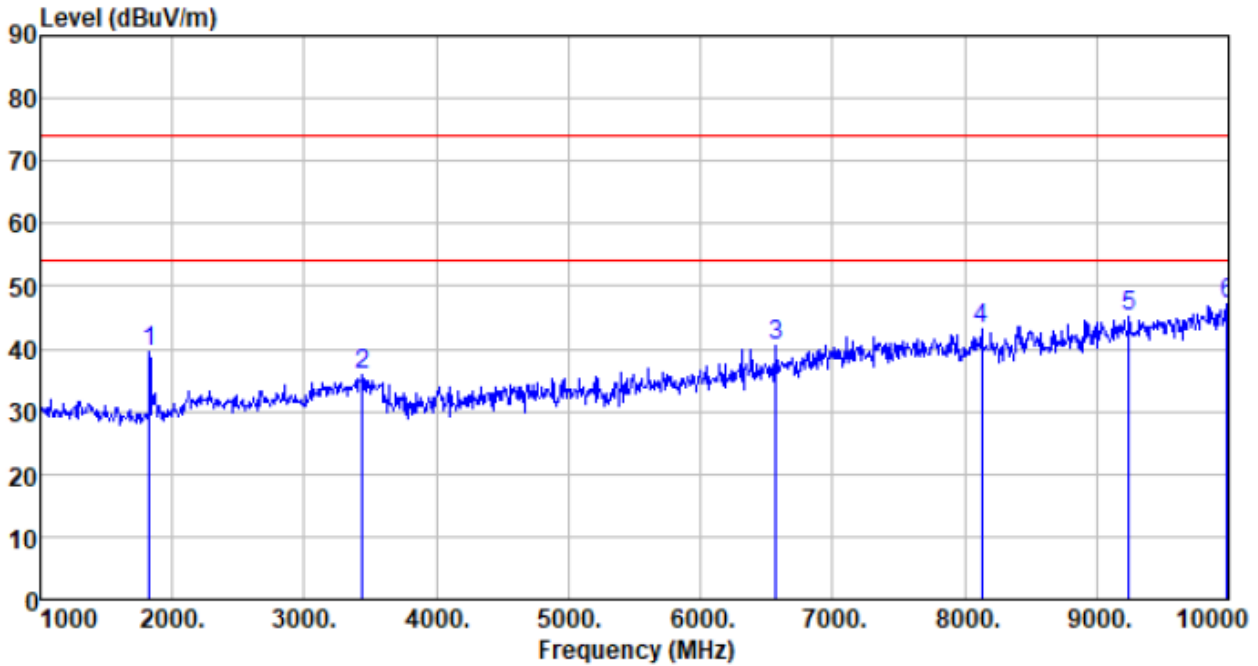

Freq MHz	Reading level dBuV	Antenna factor dB/m	Cable loss dB	Preamp factor dB	level dBuV	Limit level dBuV/m	Over limit dB	Remark
1828.000	45.24	25.85	4.87	36.40	39.56	74.00	-34.44	Peak
3439.000	38.02	28.40	6.84	37.35	35.91	74.00	-38.09	Peak
6571.000	30.83	34.56	10.98	35.99	40.38	74.00	-33.62	Peak
8128.000	28.65	37.37	12.32	35.27	43.07	74.00	-30.93	Peak
9244.000	28.24	37.64	13.84	34.67	45.05	74.00	-28.95	Peak
9991.000	29.40	38.37	14.42	35.18	47.01	74.00	-26.99	Peak

Remark:

1. Final Level = Receiver Read level + Antenna Factor + Cable Loss – Pre-amplifier Factor
2. “*”, means this data is too weak instrument of signal is unable to test.

7.8 Frequency Stability

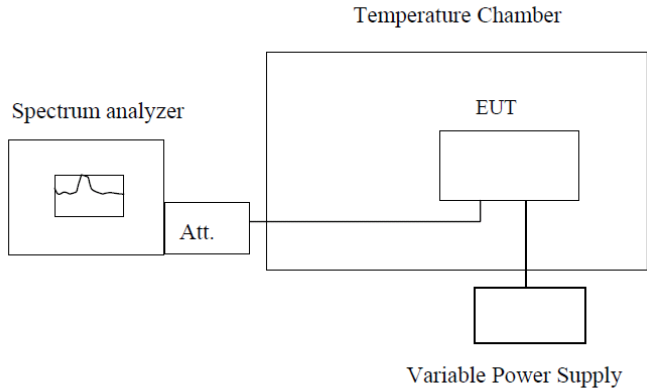
Test Requirement:	RSS-Gen Section 6.11& Section 8.11
Test Method:	ANSI C63.10: 2013 & RSS-Gen
Limit:	Manufactures of devices are responsible for ensuring frequency stability such that an emission is maintained within the band of operation under all conditions of normal operation as specified
Test Procedure:	The EUT was setup to ANSI C63.10, 2013; tested to 2.1055 for compliance to RSS-Gen requirements.
Test setup:	 <p style="text-align: center;">Note : Measurement setup for testing on Antenna connector</p>
Test Instruments:	Refer to section 6.0 for details
Test mode:	Refer to section 5.2 for details
Test results:	Pass

Remark: Set the EUT transmits at un-modulation mode to test frequency stability.

Measurement data:

Frequency stability versus Temp.						
Power Supply: AC 24V						
Temp. (°C)	Operating Frequency (MHz)	0 minute Measured Frequency (MHz)	2 minute Measured Frequency (MHz)	5 minute Measured Frequency (MHz)	10 minute Measured Frequency (MHz)	Pass /Fail
-30	915	915.43	915.44	915.06	915.83	Pass
-20	915	915.84	915.08	915.77	915.08	Pass
-10	915	915.56	915.29	915.05	915.18	Pass
0	915	915.29	915.66	915.38	915.83	Pass
10	915	915.87	915.17	915.96	915.93	Pass
20	915	915.2	915.02	915.24	915.28	Pass
30	915	915.65	915.31	915.1	915.83	Pass
40	915	915.12	915.99	915.16	915.49	Pass
50	915	915.73	915.44	915.79	915.9	Pass
Frequency stability versus Voltage						
Temperature: 25°C						
Power Supply (VAC)	Operating Frequency (MHz)	0 minute Measured Frequency (MHz)	2 minute Measured Frequency (MHz)	5 minute Measured Frequency (MHz)	10 minute Measured Frequency (MHz)	Pass /Fail
18	915	915.3	915.15	915.51	915.83	Pass
24	915	915.4	915.24	915.22	915.04	Pass
30	915	915.88	915.79	915.83	915.6	Pass

8 Test Setup Photo

Reference to the **appendix I** for details.

9 EUT Constructional Details

Reference to the **appendix II** for details.

-----End-----