

此图仅供参考，实际产品可能有所调整，请以实物为准。

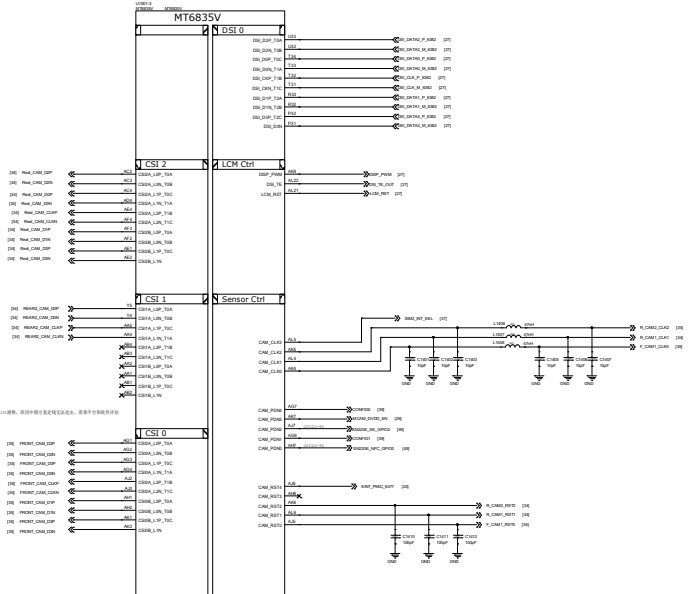

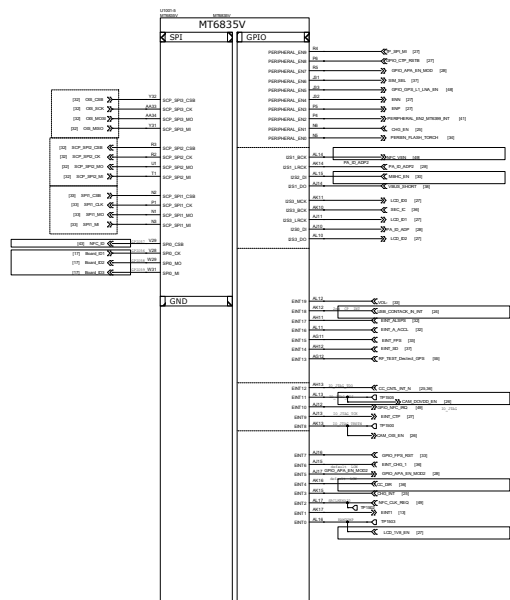

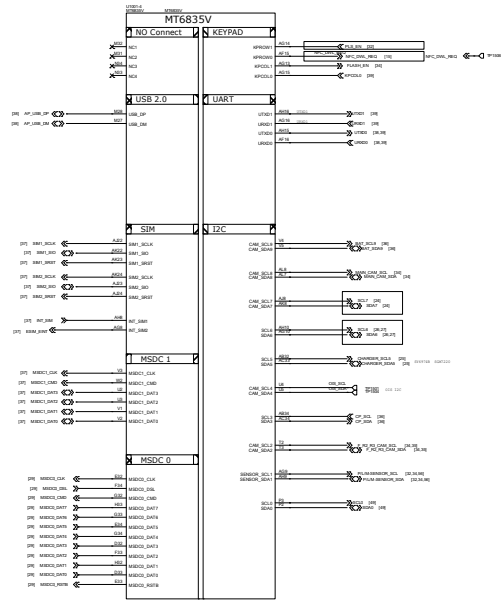

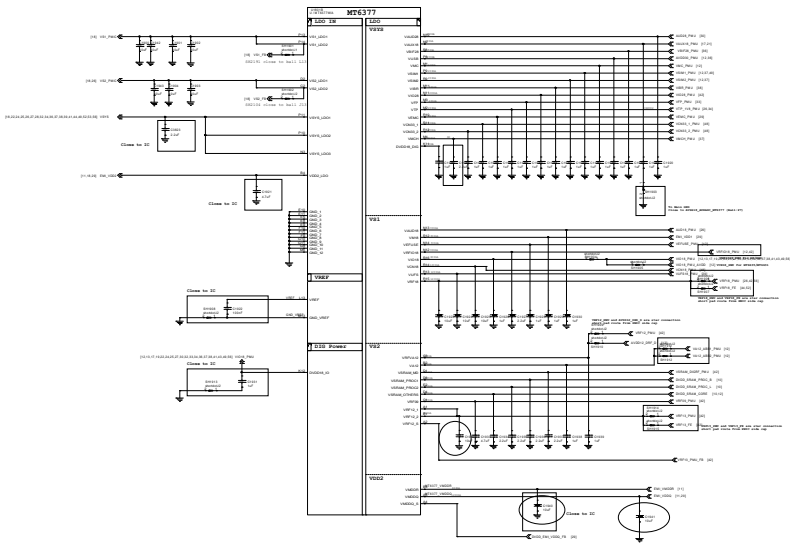
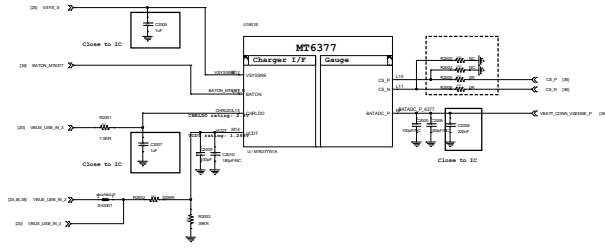
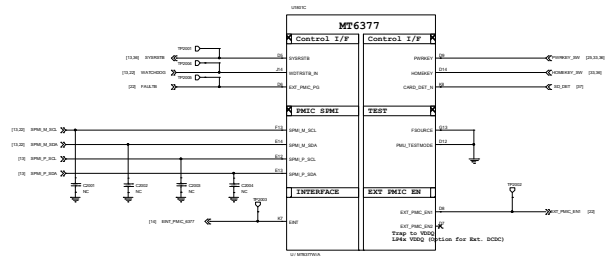

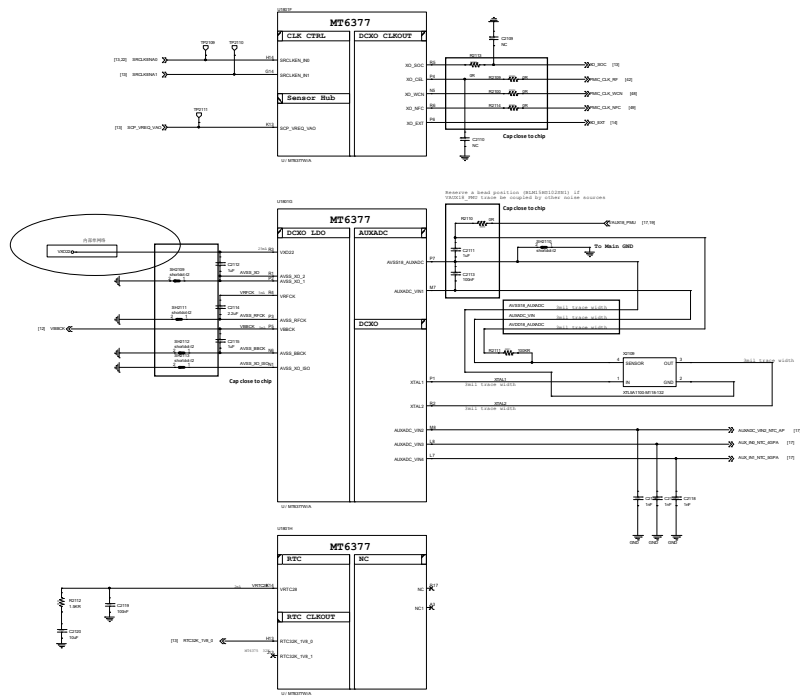

MT6319NP 4-Phase Buck (VMODEM, VSRAM_MODEM, VGPU)

PHIC 000-0411 connect to input cap. 000-0411 Err12.

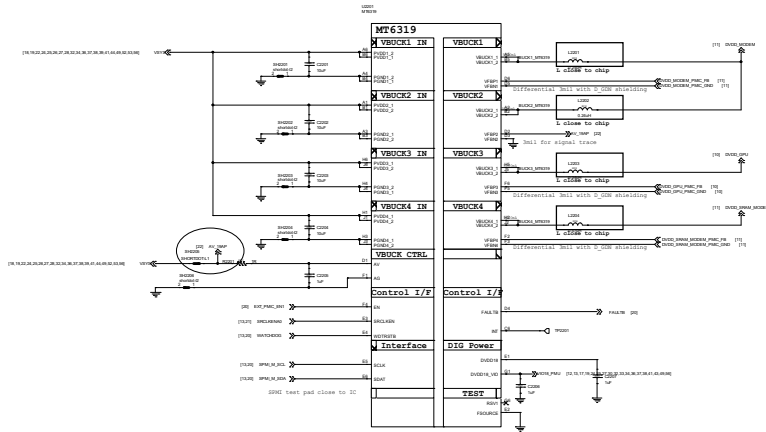

33.Headphone&Switch

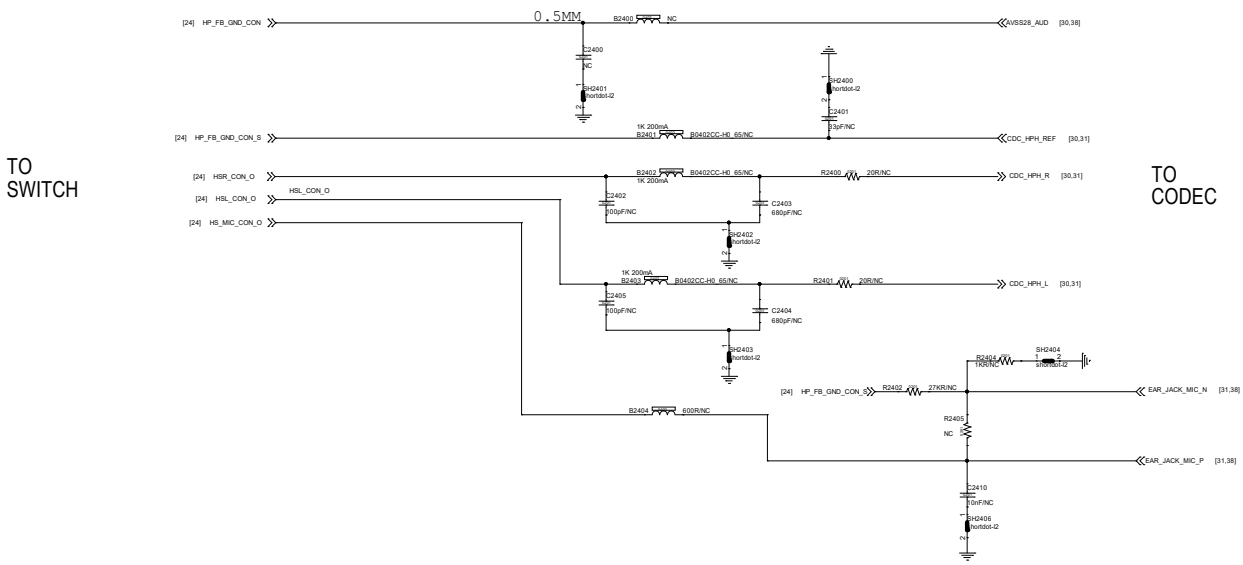

AUDIO SWITCH

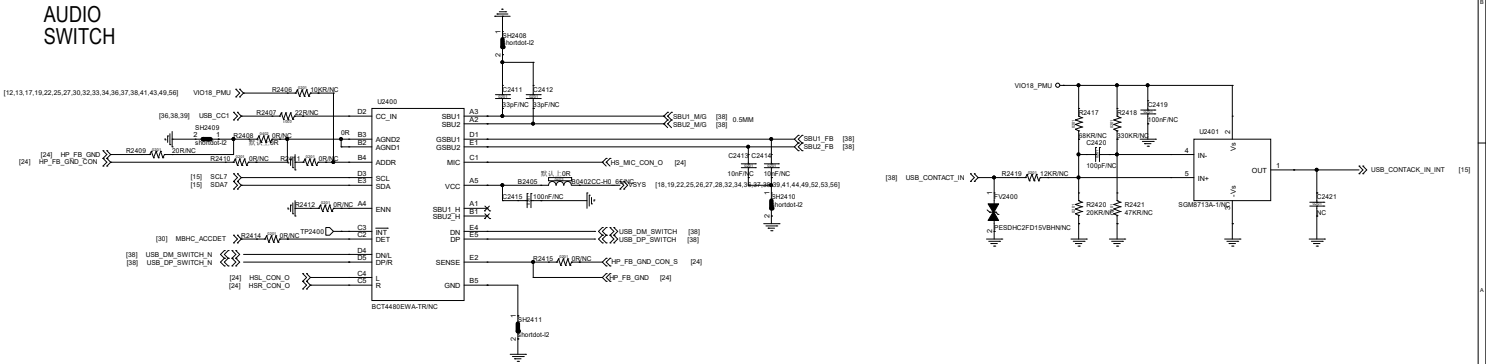

Switching Charger Power Path

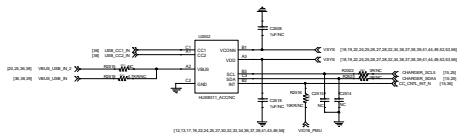
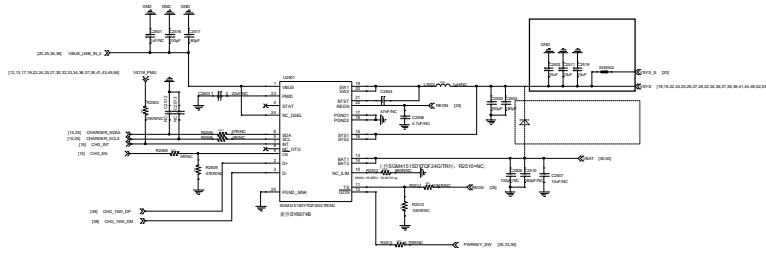

DC-DC:

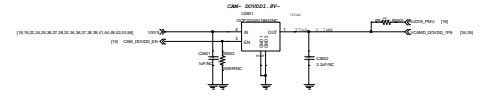
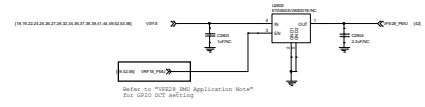
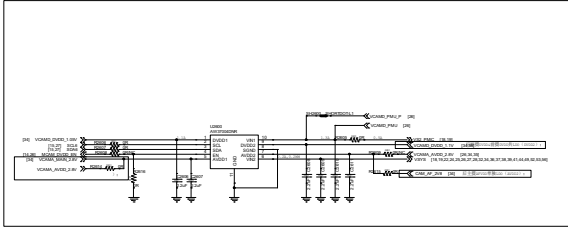
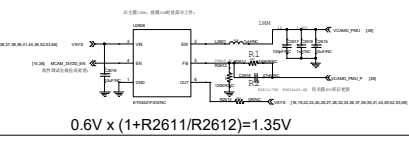

OIS_VDD:

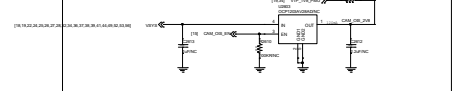

LCD&CTP-Connector

Main LCM+CTP INCELL

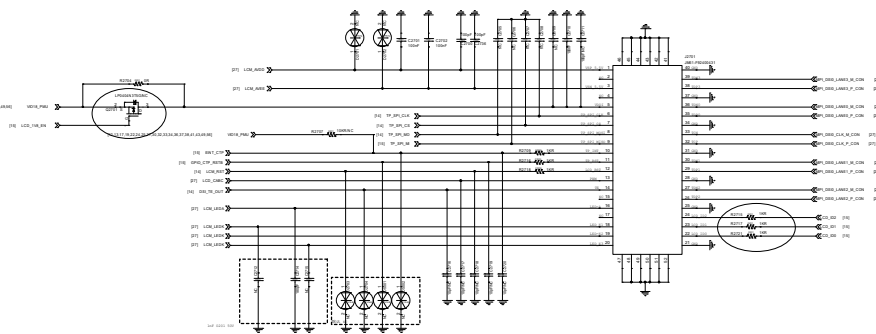

LCD MIPI Common Mode Filter

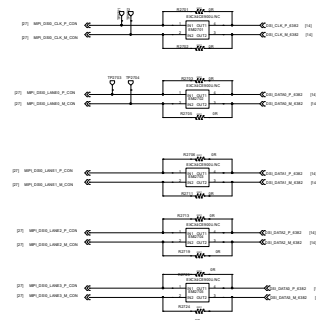

First using OR ,Second using EMI Filter.

LCM Backlight LED Driver

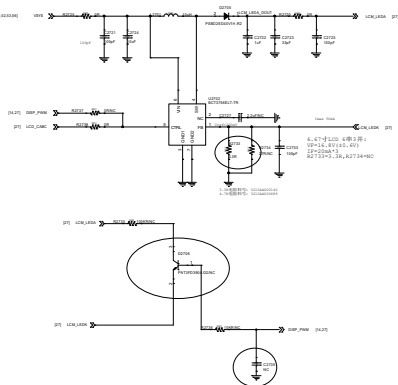

LCM Bias

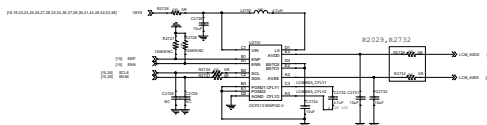

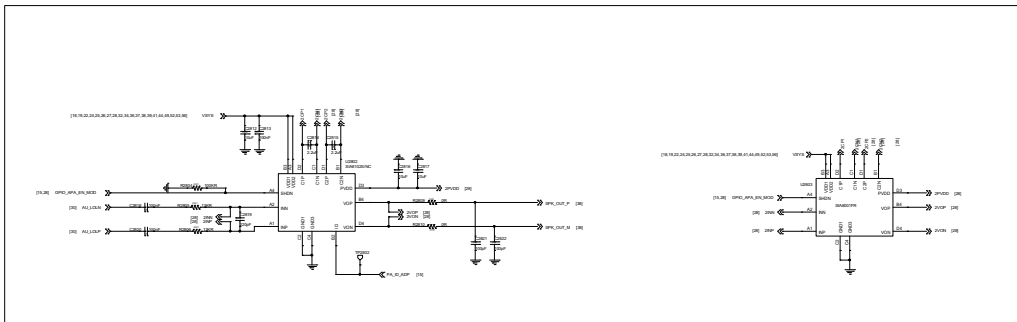
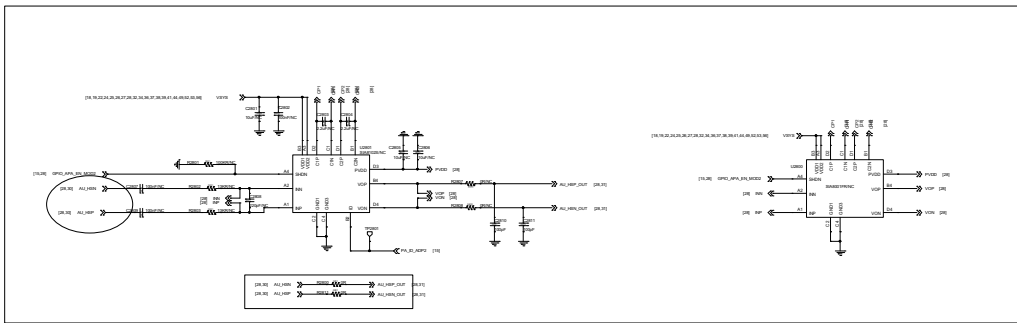

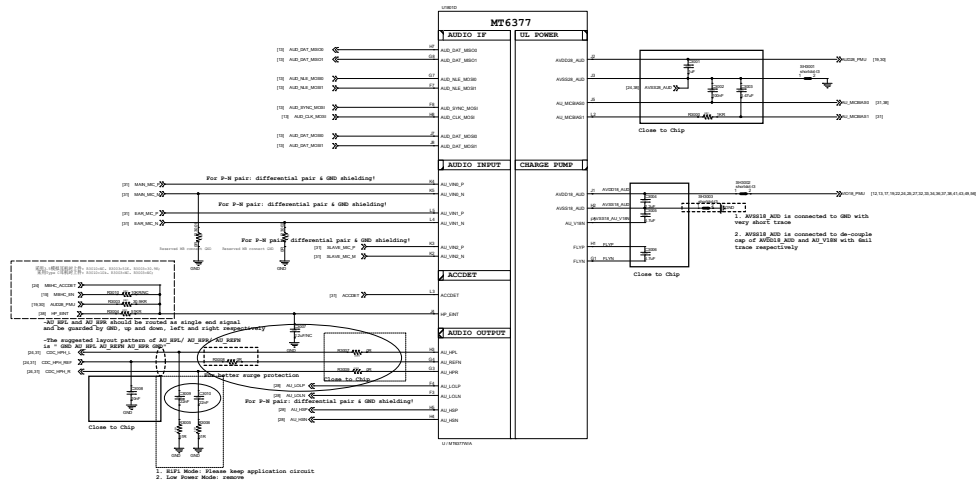

RECIVER

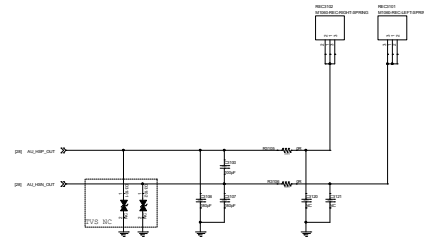
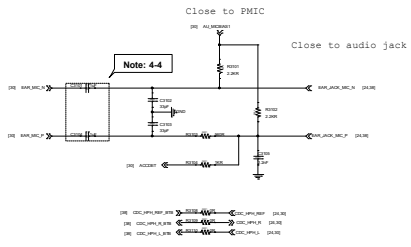

MIC -- Main

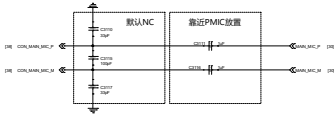

Sub MIC

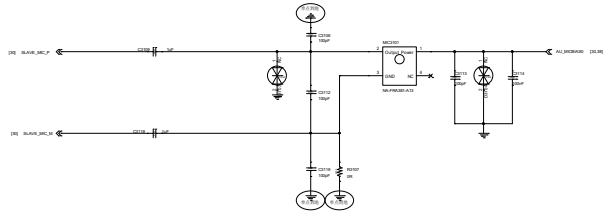

Part No.	I2C address	NOTE
HM550307	I2C Address : 0x30 (Write:0x60, Read:0x31)	
HM550308	I2C Address : 0x30 (Write:0x60, Read:0x31)	

eCOMPASS

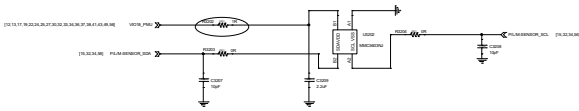

G-Sensor:STK8327

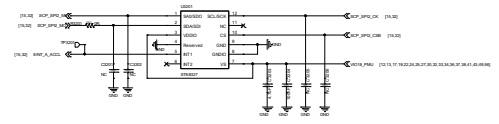

ALS & P Sensor

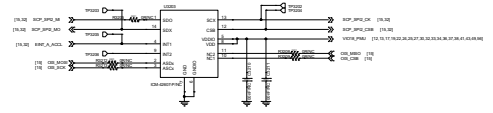
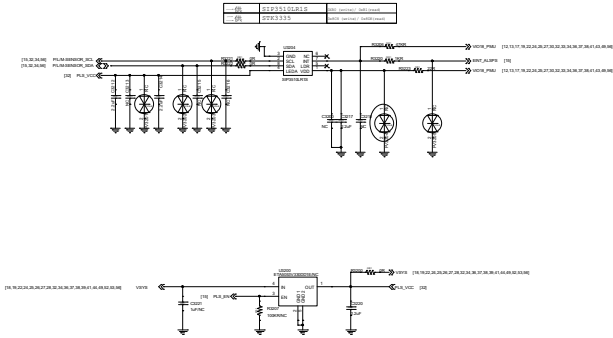

Fingerprint Connector

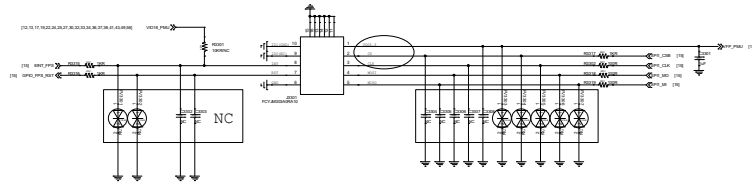

Power Key / Side Key /AI Key

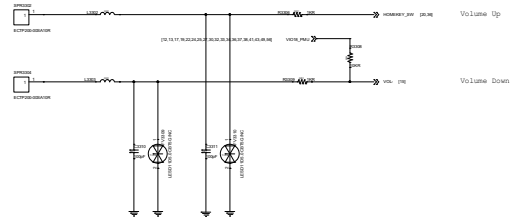
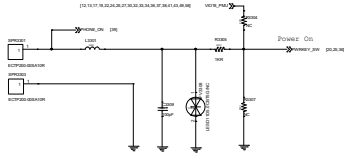

SVOOC Charger

Note 45W Charger Pump

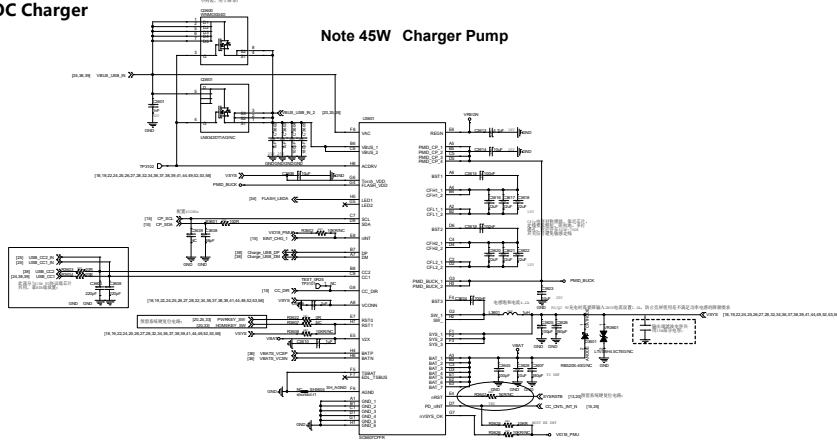

Battery Connector

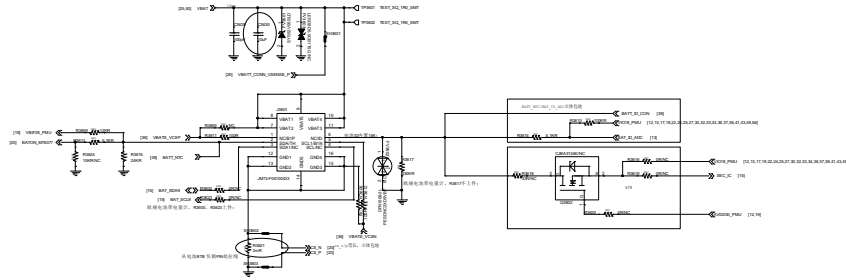

SD CARD

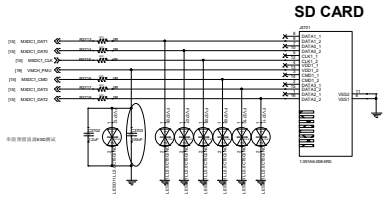

SIM1

SIM1

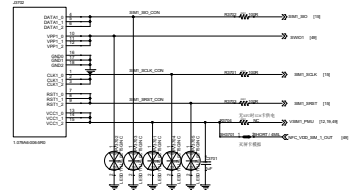

DET

CD&GND

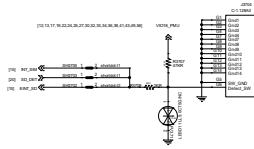

SIM2

eSIM&SIM Card Switch

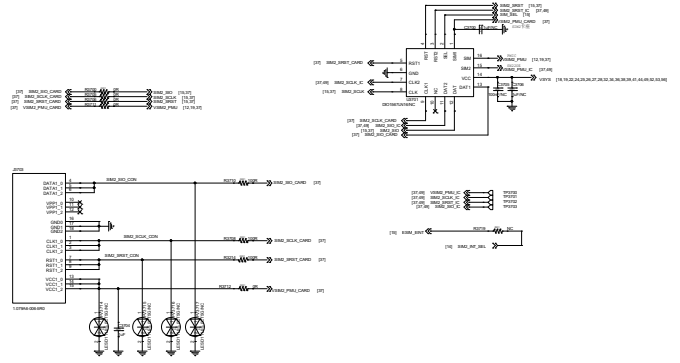

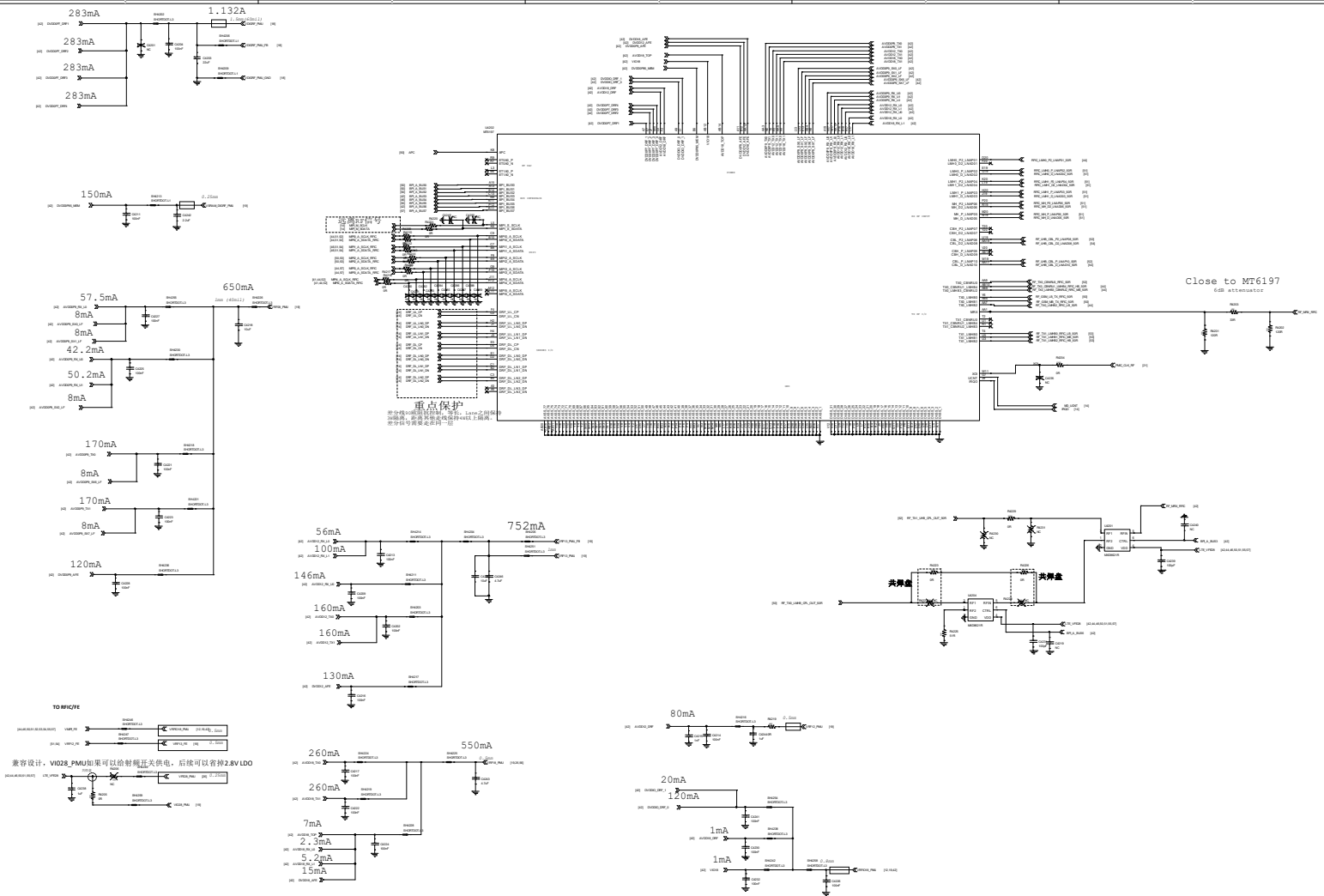

RealMe重庆移动通信有限公司
型号: RMX3943

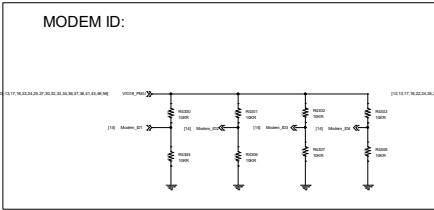

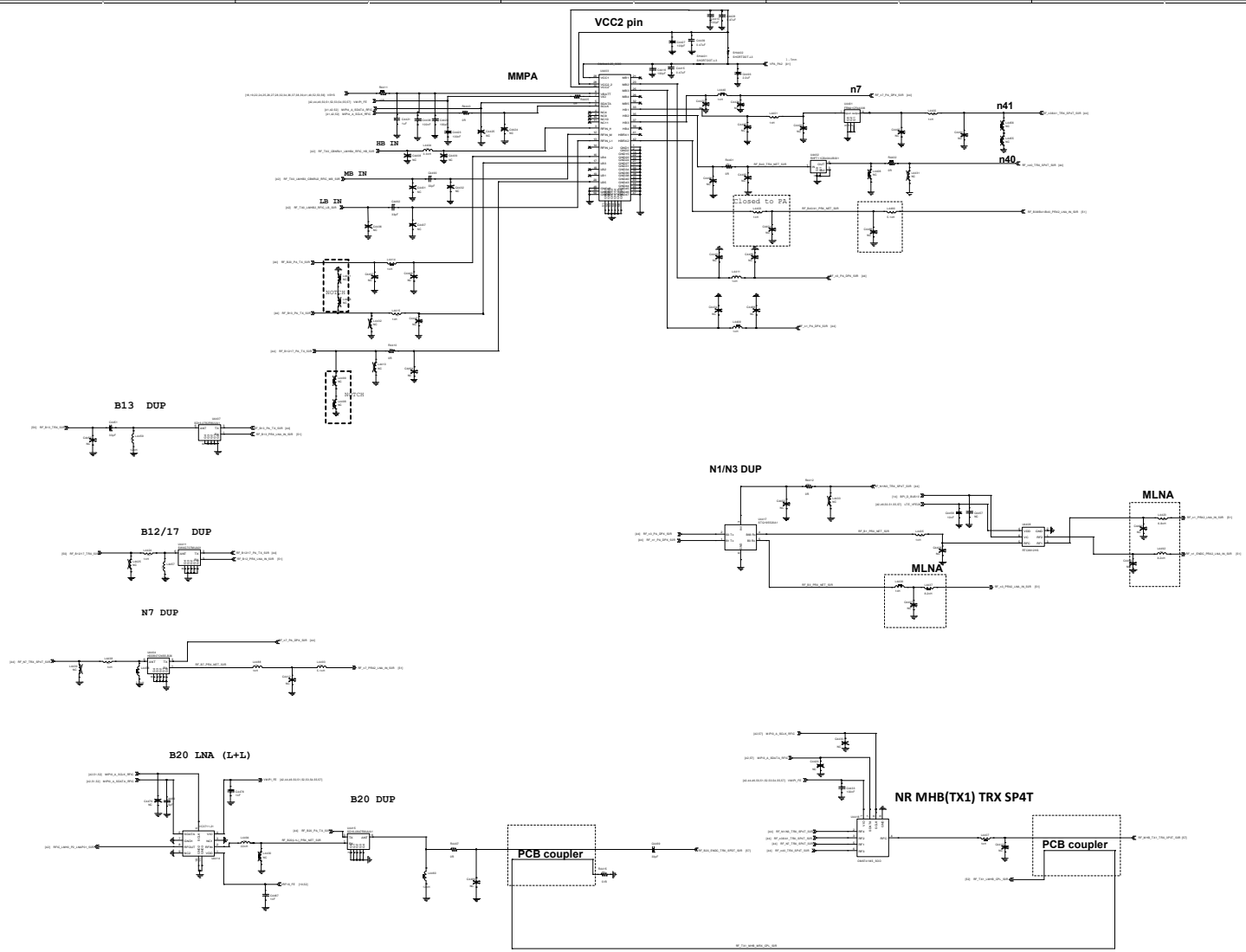

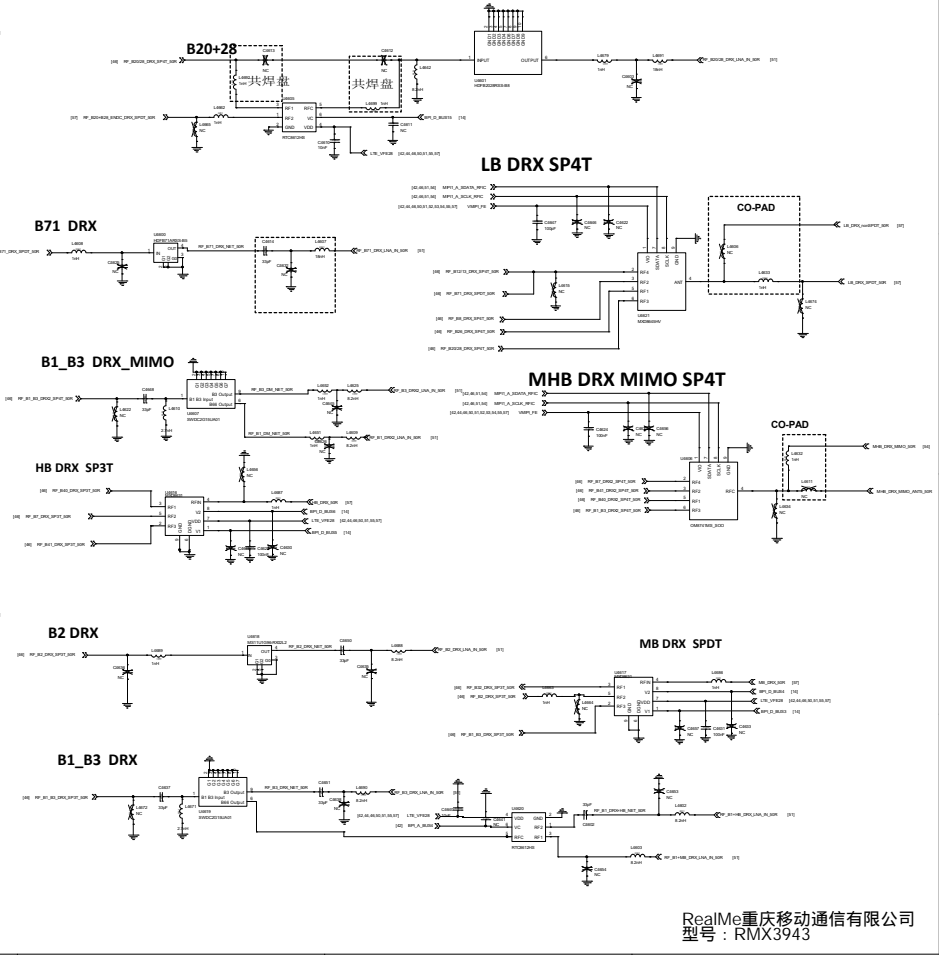
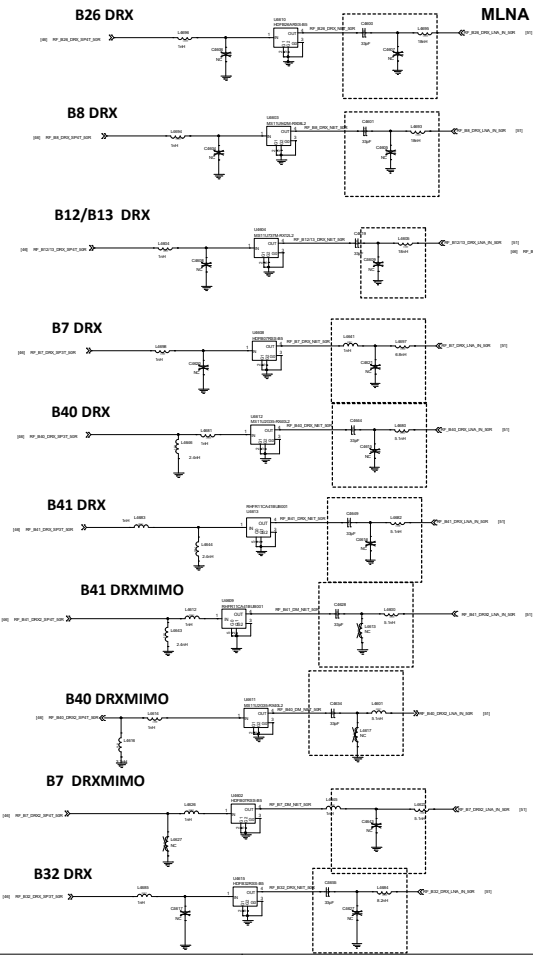

RealMe重庆移动通信有限公司
型号: RMX3943

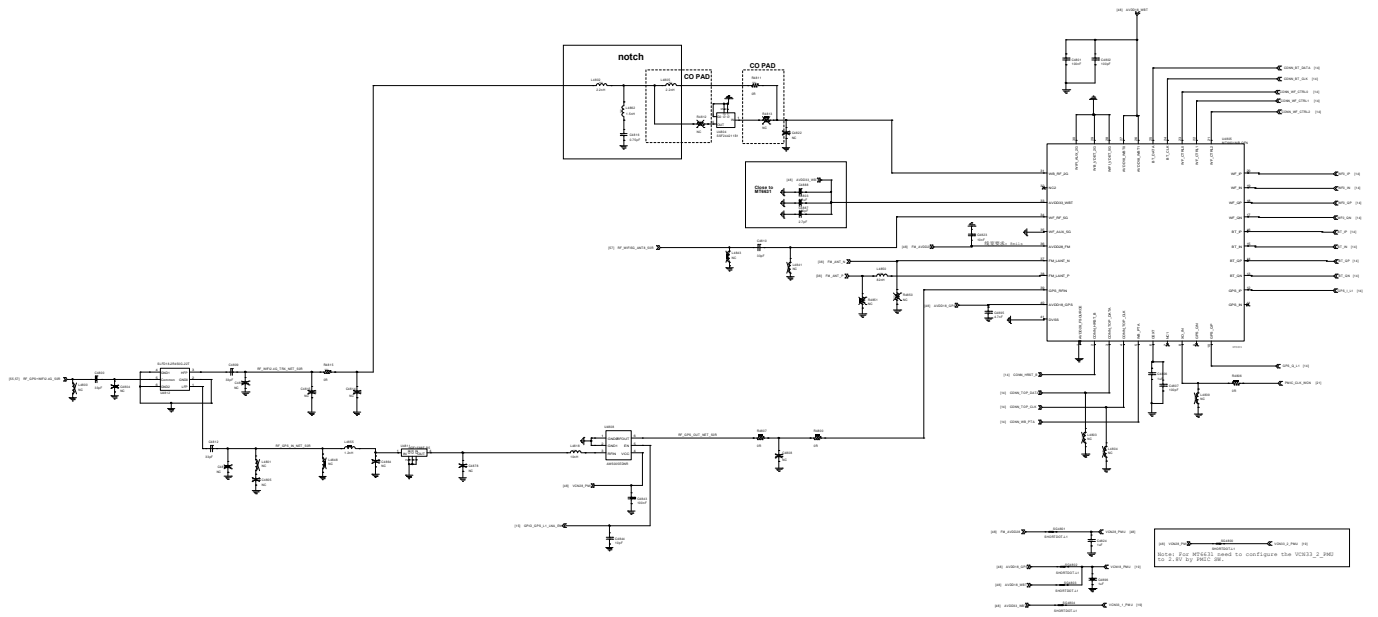

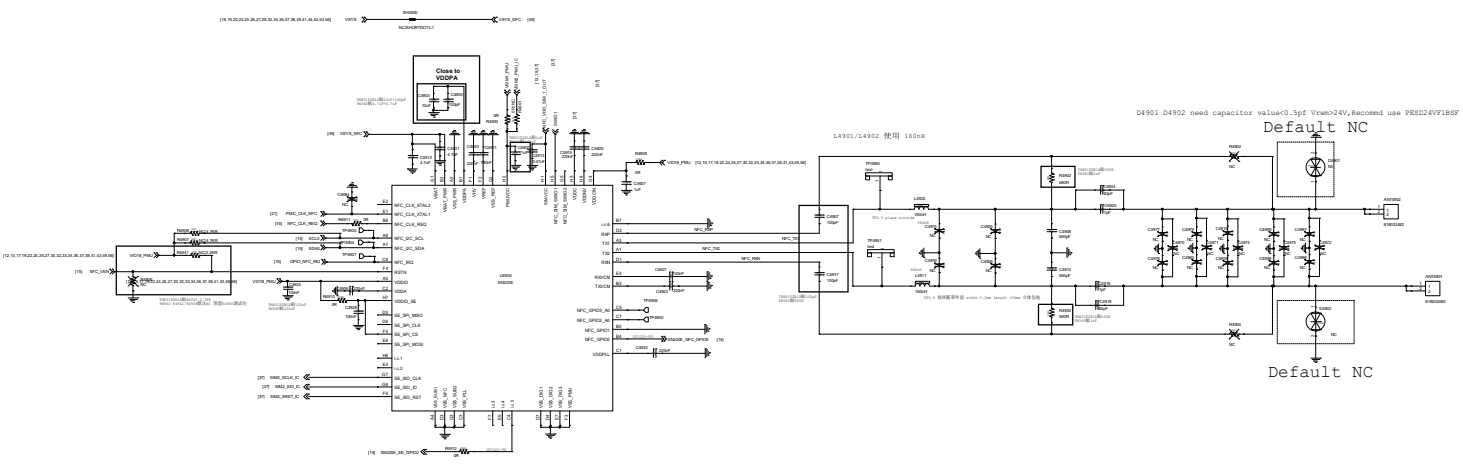

D4901 D4902 need capacitor value$0.5\mu\text{f}$ Vramo24V,Recomend use PPS024V71BSF

L4901/L4902 使用 100n

Default NC

Default NC

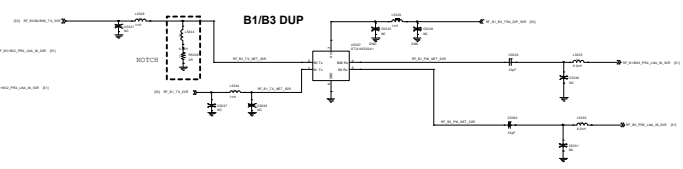
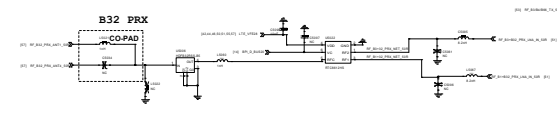
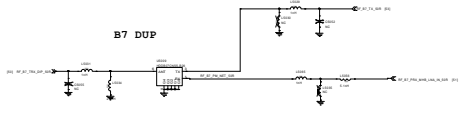
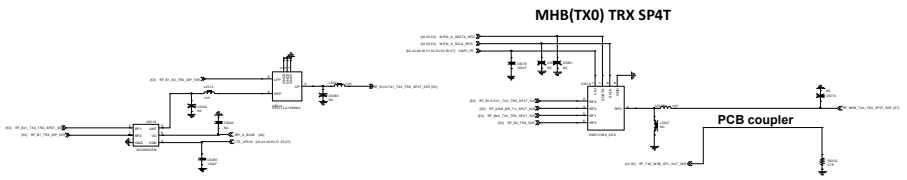
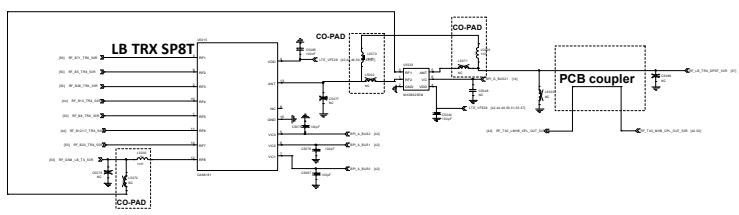
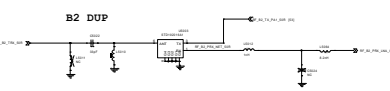
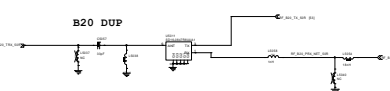
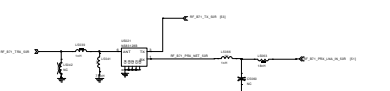
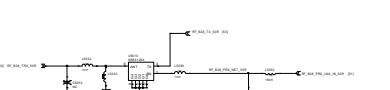
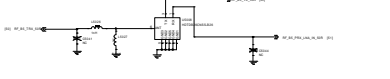
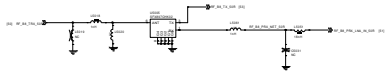
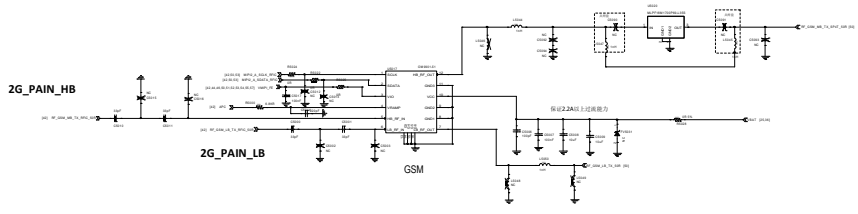

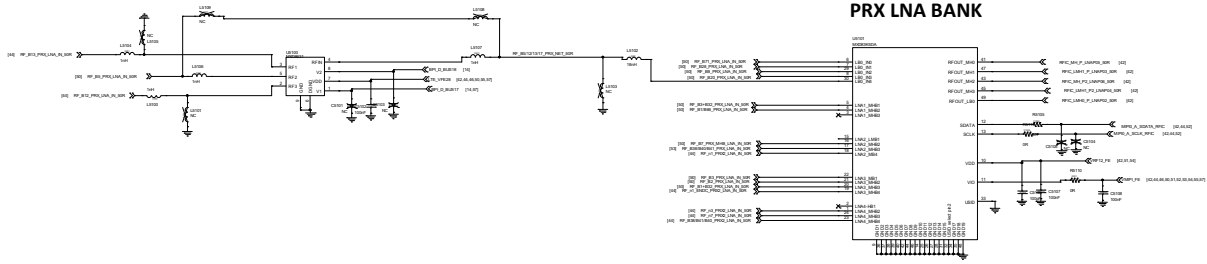

PRX LNA BANK

DRX LNA BANK

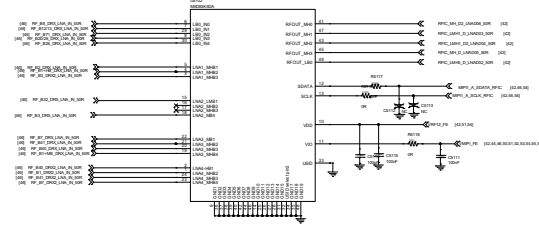

N77_TRX

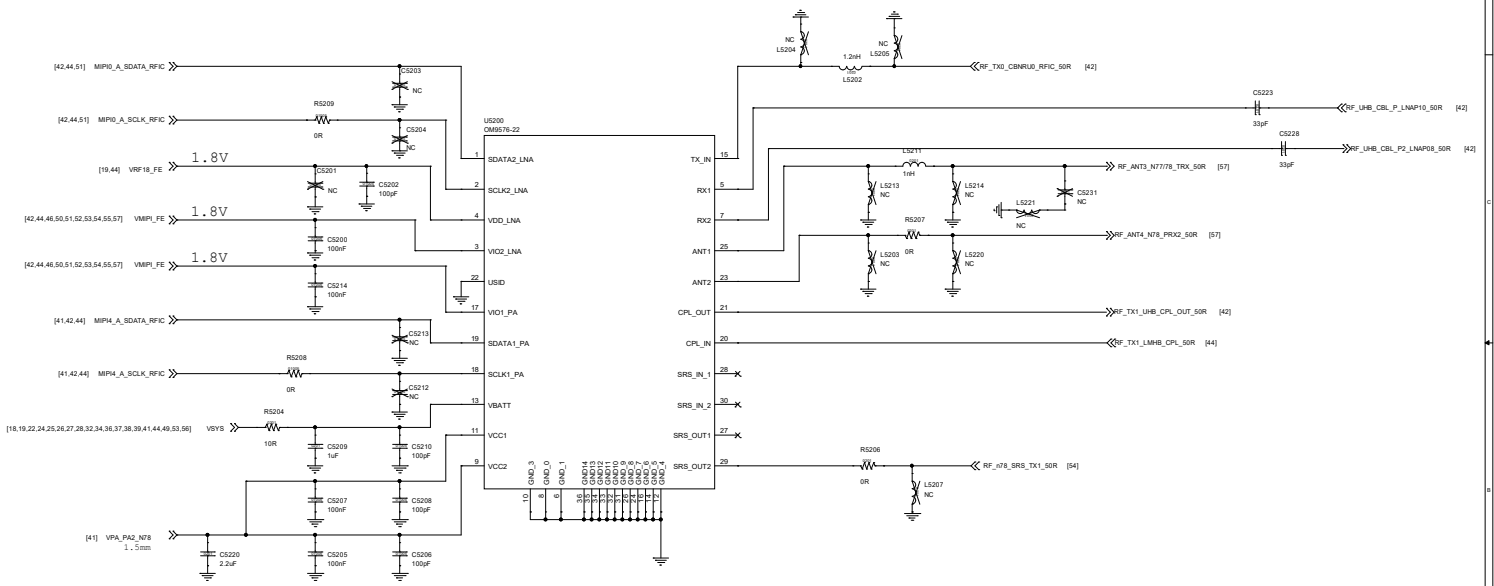

ENDC MMPA

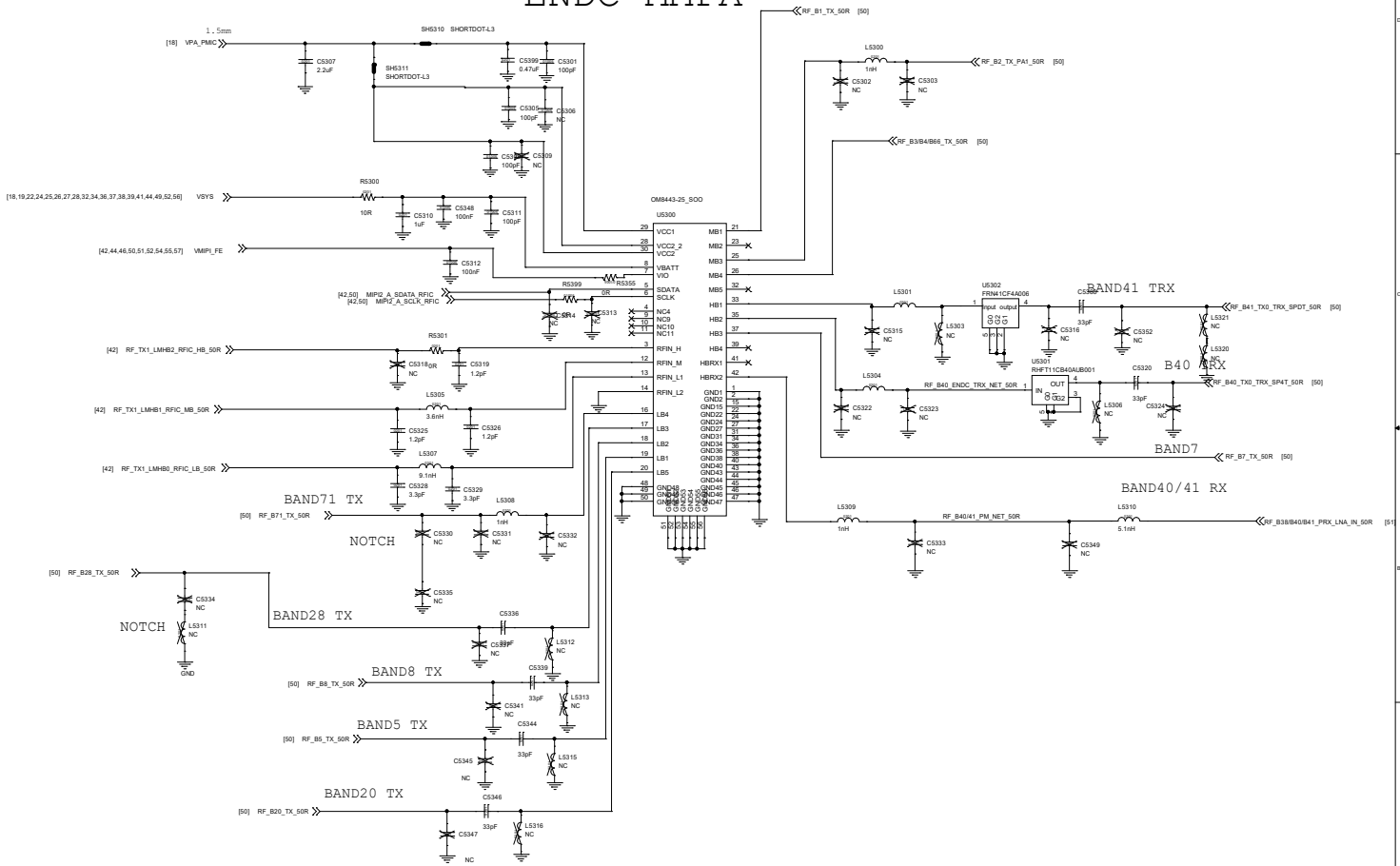

RealMe重庆移动通信有限公司
型号: RMX3943

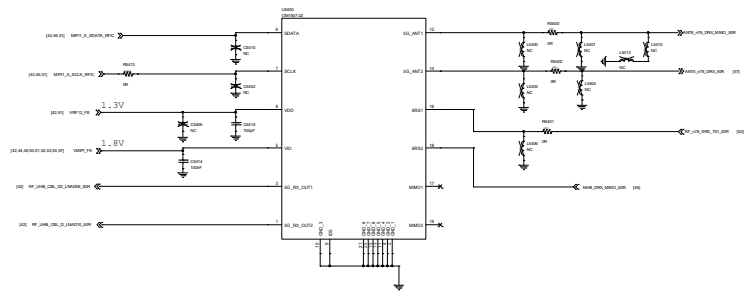

ANT0: LMHB TRX



ANT1: LB DRX + B32 PRX

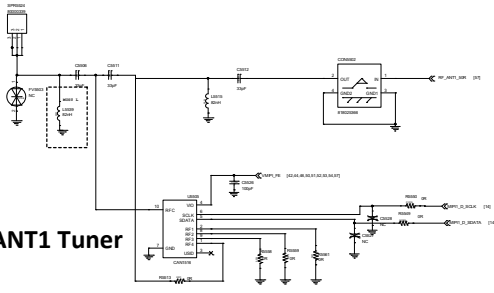

ANT1 Tuner

ANT4: MHB PRX MIMO + UHB PRX MIMO

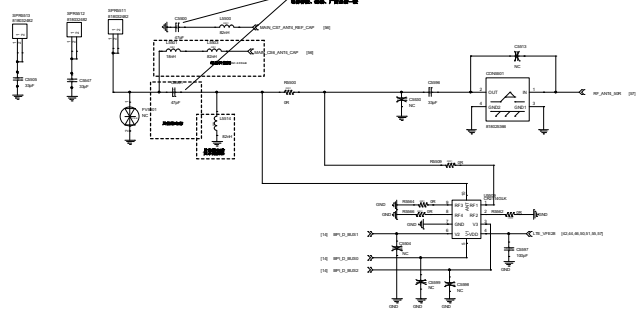

ANT5: PRX + MHB PRX MIMO + UHB DRX MIMO

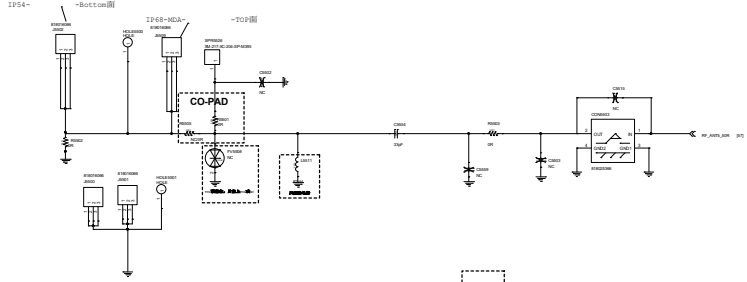

ANT2: L+L B20_N28 DRX

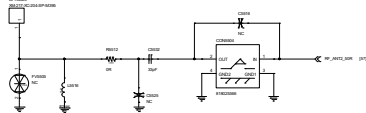

ANT3: UHB PRX + MHB DRX

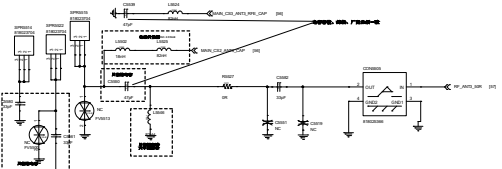

ANT3 Tuner

ANT8: UHB DRX + WIFI 5G

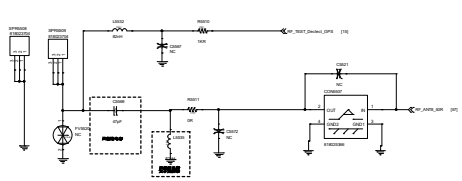

ANT9 : GPS + WIFI 2.4G

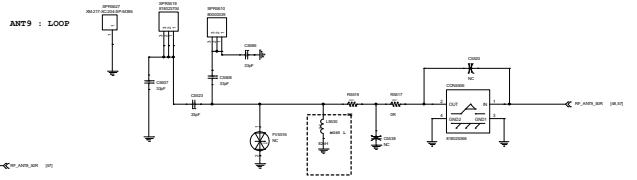

SAR sensor

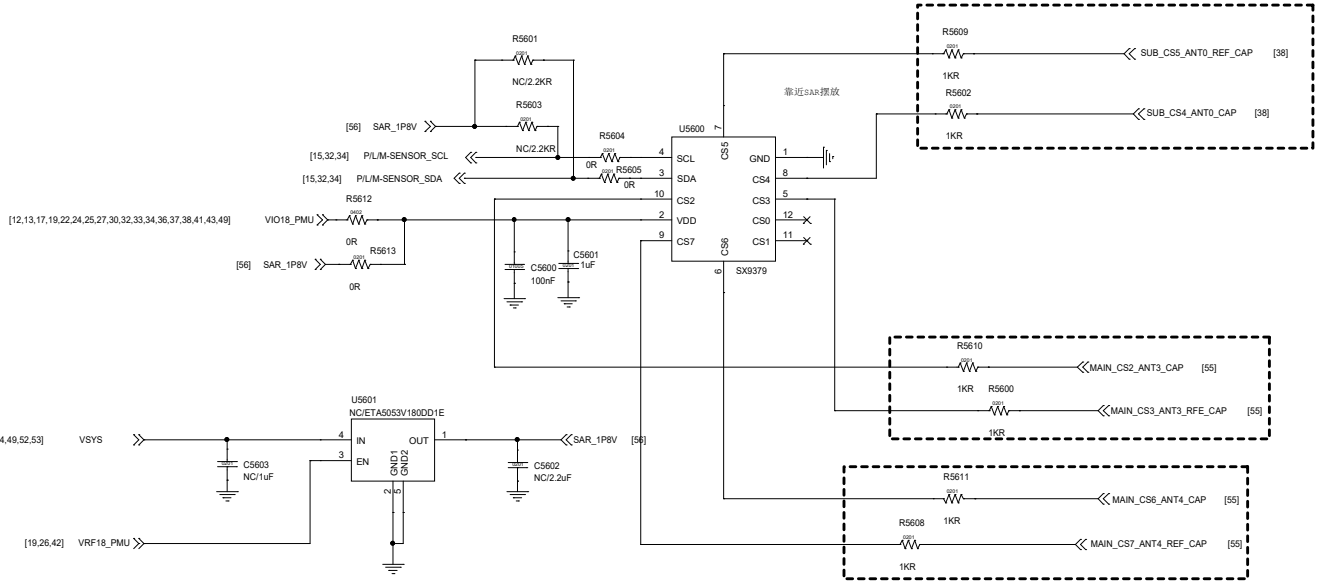

ANT0: MHB TRX + LB DRX

MHB 3P3T (MHB)

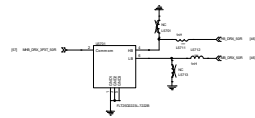
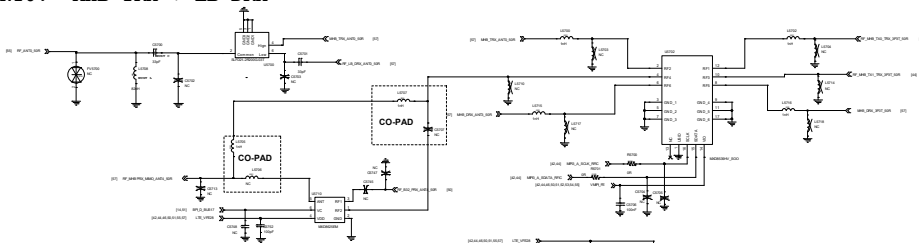

ANT1: LB PRX + B32 PRX

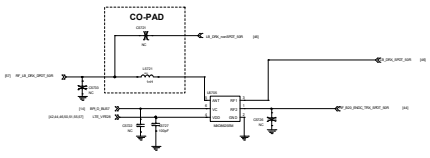
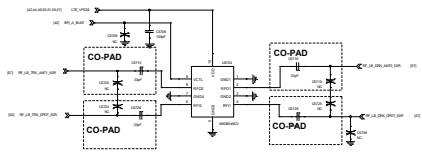
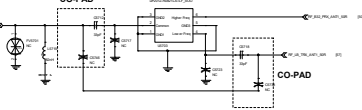

ANT2: L+L B20_N28 DRX

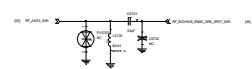

ANT5: MHB PRX MIMO + UHB DRX MIMO

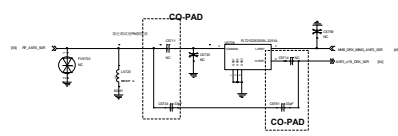

ANT3: UHB PRX + MHB DRX

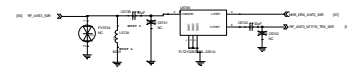

ANT9 : GPS + WIFI 2.4G

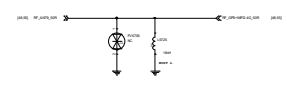

ANT8: UHB DRX + WIFI 5G

ANT4: B32 DRX + MHB PRX MIMO + UHB PRX MIMO

