

FCC TEST REPORT

For

Mobile Phone

Model Number: RMX3630

FCC ID: 2AUYFRMX3630

Report Number : WT228002152

Test Laboratory : Shenzhen Academy of Metrology and Quality
Inspection
Site Location : NETC Building, No.4 Tongfa Rd., Xili, Nanshan,
Shenzhen, China
Tel : 0086-755-86928965
Fax : 0086-755-86009898-31396
Web : www.smq.com.cn
E-mail : emcrf@smq.com.cn

Revision History

No	Date	Remark
V1.0	2022.09.21	Initial issue

TEST REPORT DECLARATION

Applicant : Realme Chongqing Mobile Telecommunications Corp., Ltd.
Address : No.178 Yulong Avenue, Yufengshan, Yubei District,
Chongqing, China
Manufacturer : Realme Chongqing Mobile Telecommunications Corp., Ltd.
Address : No.178 Yulong Avenue, Yufengshan, Yubei District,
Chongqing, China
EUT Description : Mobile Phone
Model No. : RMX3630
Trade mark : realme
Serial Number : /
FCC ID : 2AUYFRMX3630

Test Standards:

FCC Part 15 Subpart E 15.407 (2020)

The EUT described above is tested by Shenzhen Academy of Metrology and Quality Inspection EMC Laboratory to determine the maximum emissions from the EUT. Shenzhen Academy of Metrology and Quality Inspection EMC Laboratory is assumed full responsibility for the accuracy of the test results. The test data, data evaluation, test procedures, and equipment configurations shown in this report were made in accordance with the procedures given in ANSI C63.10 (2013) and the energy emitted by the sample EUT tested as described in this report is in compliance with FCC Rules Part 15.407.

The test report is valid for above tested sample only and shall not be reproduced in part without written approval of the laboratory.

Project Engineer:  Date: Sep.21, 2022
(Zhou Fangai 周芳媛)
Checked by:  Date: Sep.21, 2022
(Shi Changda 施昌达)
Approved by:  Date: Sep.21, 2022
(Lin Yixiang 林奕翔)

TABLE OF CONTENTS

TEST REPORT DECLARATION	3
1. TEST RESULTS SUMMARY	5
2. GENERAL INFORMATION	6
2.1. Report information.....	6
2.2. Laboratory Accreditation and Relationship to Customer	6
3. PRODUCT DESCRIPTION.....	7
3.1. EUT Description.....	7
3.2. Related Submittal(s) / Grant (s)	8
3.3. Block Diagram of EUT Configuration	8
3.4. Operating Condition of EUT	9
3.5. Support Equipment List	10
3.6. Test Conditions.....	10
3.7. Special Accessories.....	10
3.8. Equipment Modifications	10
4. TEST EQUIPMENT USED	11
5. TRANSMIT POWER CONTROL	12
5.1. LIMITS OF TRANSMIT POWER CONTROL.....	12
5.2. TEST DATA.....	12
6. DYNAMIC FREQUENCY SELECTION	13
6.1. LIMITS OF DYNAMIC FREQUENCY SELECTION	13
6.2. TEST PROCEDURE.....	16
6.3. TEST DATA.....	16

1. TEST RESULTS SUMMARY

Table 1 Test Results Summary

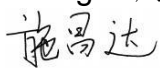
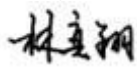
Test Items	FCC Rules	Test Results
Transmit Power Control	FCC §15.407 (h)	N/A
Channel Closing Transmission Time	FCC §15.407 (h)	Pass
Channel Move Time	FCC §15.407 (h)	Pass
Non-Occupancy Period	FCC §15.407 (h)	Pass

Remark: "N/A" means "Not applicable."

Note: 5G WLAN not support wireless hotspot mode.

2. GENERAL INFORMATION

2.1. Report information

This report is not a certificate of quality; it only applies to the sample of the specific product/equipment given at the time of its testing. The results are not used to indicate or imply that they are application to the similar items. In addition, such results must not be used to indicate or imply that SMQ approves recommends or endorses the manufacture, supplier or use of such product/equipment, or that SMQ in any way guarantees the later performance of the product/equipment.

The sample/s mentioned in this report is/are supplied by Applicant, SMQ therefore assumes no responsibility for the accuracy of information on the brand name, model number, origin of manufacture or any information supplied.

Additional copies of the report are available to the Applicant at an additional fee. No third part can obtain a copy of this report through SMQ, unless the applicant has authorized SMQ in writing to do so.

The lab will not be liable for any loss or damage resulting for false, inaccurate, inappropriate or incomplete product information provided by the applicant/manufacturer.

2.2. Laboratory Accreditation and Relationship to Customer

The testing report were performed by the Shenzhen Academy of Metrology and quality Inspection EMC Laboratory (Guangdong EMC compliance testing center), in their facilities located at NETC Building, No.4 Tongfa Rd., Xili, Nanshan, Shenzhen, China. At the time of testing, Laboratory is accredited by the following organizations:

China National Accreditation Service for Conformity Assessment (CNAS) accredits the Laboratory for conformance to FCC standards, EMC international standards and EN standards. The Registration Number is CNAS L0579.

The Laboratory is Accredited Testing Laboratory of FCC with Designation number CN1165 and Site registration number 582918.

The Laboratory is registered to perform emission tests with Innovation, Science and Economic Development (ISED), and the registration number is 11177A.

The Laboratory is registered to perform emission tests with VCCI, and the registration number are C-20048, G20076, R-20077, R-20078 and T-20047.

The Laboratory is Accredited Testing Laboratory of American Association for Laboratory Accreditation (A2LA) and certificate number is 3292.01.

3. PRODUCT DESCRIPTION

NOTE: The extreme test conditions for temperature and antenna gain were declared by the manufacturer.

3.1.EUT Description

Description : Mobile Phone

Manufacturer : Realme Chongqing Mobile Telecommunications Corp., Ltd.

Model Number : RMX3630

Operate Frequency : U-NII 2A(5260~5320MHz)
U-NII 2C(5500~5700MHz)

Antenna Designation : Fixed Internal Antenna
U-NII 2A (5260~5320 MHz) -0.2 dBi
U-NII 2C (5500~5700 MHz) -0.1 dBi

Operating voltage : DC3.4V (Low)/DC3.87V (Nominal)/DC4.45V (Max)

Software Version : realme UI V3.0

Hardware Version : 11

Remark: --

Table 2 Working Frequency List U-NII 2A (802.11a, 802.11n, 802.11ac (20MHz))

Channel	Frequency	Channel	Frequency
52	5260 MHz	60	5300 MHz
56	5280 MHz	64	5320 MHz

Table 3 Working Frequency List U-NII 2A (802.11n, 802.11ac (40MHz))

Channel	Frequency	Channel	Frequency
54	5270 MHz	62	5310 MHz

Table 4 Working Frequency List U-NII 2A (802.11ac (80MHz))

Channel	Frequency	Channel	Frequency
58	5290MHz	--	--

Table 5 Working Frequency List U-NII 2C (802.11a, 802.11n, 802.11ac (20MHz))

Channel	Frequency	Channel	Frequency
100	5500 MHz	124	5620 MHz
104	5520 MHz	128	5640 MHz
108	5540 MHz	132	5660 MHz
112	5560 MHz	136	5680 MHz
116	5580 MHz	140	5700 MHz
120	5600 MHz	--	--

Table 6 Working Frequency List U-NII 2C (802.11n, 802.11ac (40MHz))

Channel	Frequency	Channel	Frequency
---------	-----------	---------	-----------

102	5510 MHz	126	5630 MHz
110	5550 MHz	134	5670 MHz
118	5590 MHz	--	--

Table 7 Working Frequency List U-NII 2C (802.11ac (80MHz))

Channel	Frequency	Channel	Frequency
106	5530 MHz	122	5610 MHz

3.2. Related Submittal(s) / Grant (s)

This submittal(s) (test report) is intended for FCC ID: **2AUYFRMX3630** filing to comply with Section 15.407 of the FCC Part 15, Subpart E.

3.3. Block Diagram of EUT Configuration

Setup for Master with injection at the Master

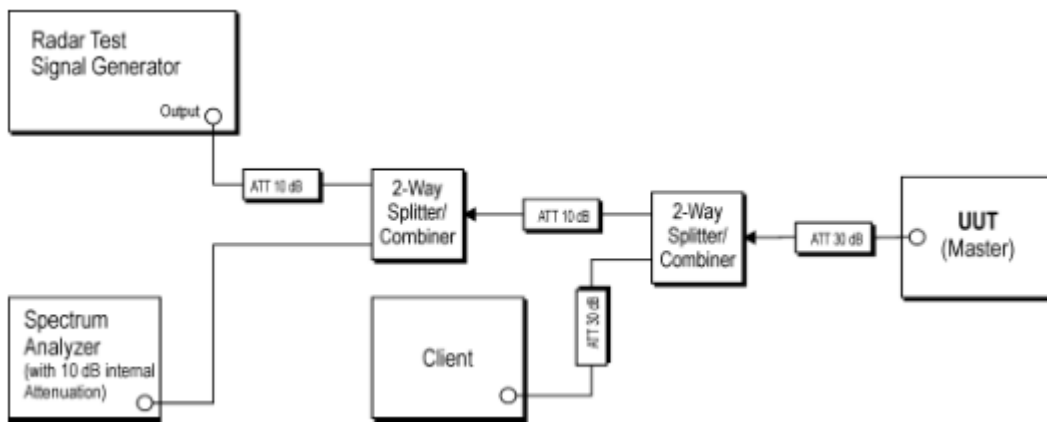

Figure 1 Example Conducted Setup where UUT is a Master and Radar Test Waveforms are injected into the Master

Setup for Client with injection at the Master

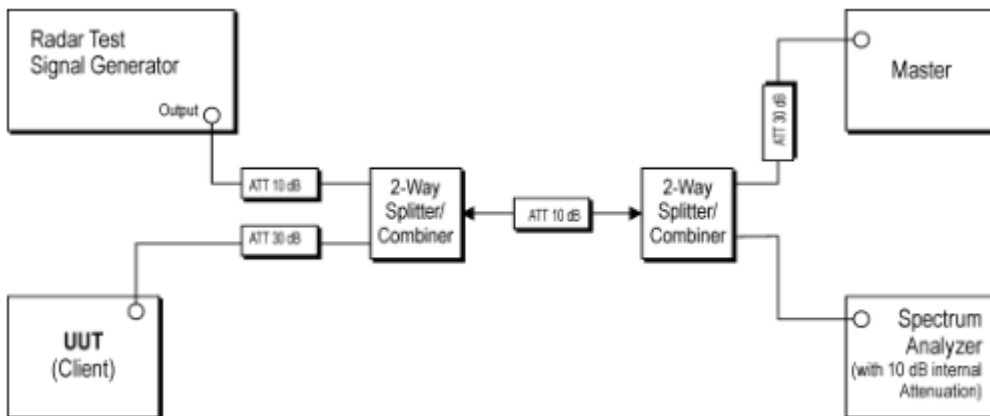

Figure 2 Example Conducted Setup where UUT is a Client and Radar Test Waveforms are injected into the Master

Setup for Client with injection at the Client

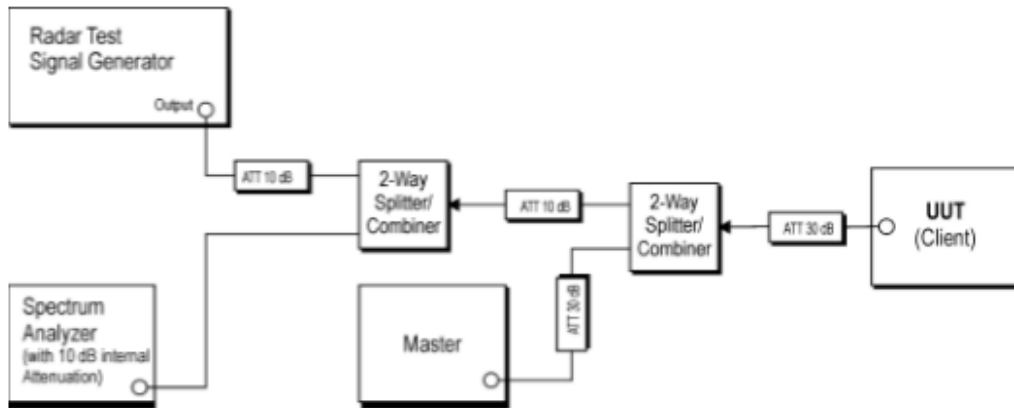

Figure 3 Example Conducted Setup where UUT is a Client and Radar Test Waveforms are injected into the Client

3.4. Operating Condition of EUT

The EUT utilizes the 802.11n architecture. Two nominal channel bandwidths are implemented: 20MHz, 40MHz, 80MHz. Only test the widest BW: 80MHz. The conducted power tables are as follows:

802.11a Mode

Channel	Frequency (MHz)	Power
		dBm
52	5260	17.17
56	5280	17.02
64	5320	13.89
100	5500	13.62
116	5600	17.37
140	5700	11.97

802.11n HT20 Mode

Channel	Frequency (MHz)	Power
		dBm
52	5260	17.17
56	5280	17.11
64	5320	13.23
100	5500	13.31
116	5600	17.09
140	5700	12.01

802.11n HT40 Mode

Channel	Frequency (MHz)	Power
		dBm
54	5270	15.91
62	5310	11.78
102	5510	11.62
110	5590	16.99
134	5670	14.04

802.11ac VHT20 Mode

Channel	Frequency (MHz)	Power
		dBm
52	5260	16.27
56	5280	16.06
64	5320	13.14
100	5500	12.64
116	5600	16.06
140	5700	11.02

802.11ac VHT40 Mode

Channel	Frequency (MHz)	Power
		dBm
54	5270	15.20
62	5310	11.16
102	5510	10.36
110	5590	16.07
134	5670	12.68

802.11ac VHT80 Mode

Channel	Frequency (MHz)	Power
		dBm
58	5290	11.10
106	5530	10.75
122	5610	14.81

3.5. Support Equipment List

Table 8 Support Equipment List

Name	Model No.	S/N	Manufacturer	FCC
Notebook	E460	---	Lenovo	DOC
Nighthawk X4S AC2600 Smart WiFi Router	R7800	---	NETGEAR	ID:PY315100319

3.6. Test Conditions

Date of test : Aug.31, 2022- Sep.20, 2022

Date of EUT Receive : Aug.29, 2022

Temperature: 21°C-26°C

Relative Humidity: 48%-54%

3.7. Special Accessories

Not available for this EUT intended for grant.

3.8. Equipment Modifications

Not available for this EUT intended for grant.

4. TEST EQUIPMENT USED

Table 9 Test Equipment

No.	Equipment	Manufacturer	Model No.	Last Cal.	Cal. Interval
SB9060	Spectrum Analyzer	R&S	FSQ40	Apr.26,2022	1 Year
SB11873/02	Vector Signal Generator	R&S	SMBV100A	Apr.26,2022	1 Year
SB11873/01	Power sensor, Power Meter	R&S	OSP120+OSP-B157	Apr.26,2022	1 Year
SB11895	Attenuator	Agilent	8496B	Mar.10,2022	1 Year

Table 10 Test software

Name	Manufacturer	Version
Bluetooth and WiFi Test System	Shenzhen JS tonscond co.,ltd	2.6.87.0615

5. TRANSMIT POWER CONTROL

5.1. LIMITS OF TRANSMIT POWER CONTROL

CFR 47 (FCC) part 15.2407 (h)(1)

U-NII devices operating in the 5.25-5.35 GHz band and the 5.47-5.725 GHz band shall employ a TPC mechanism. The U-NII device is required to have the capability to operate at least 6 dB below the mean EIRP value of 30 dBm. A TPC mechanism is not required for systems with an e.i.r.p. of less than 500 mW.

5.2. TEST DATA

N/A

6. DYNAMIC FREQUENCY SELECTION

6.1. LIMITS OF DYNAMIC FREQUENCY SELECTION

CFR 47 (FCC) part 15.407 (h) (1) and kdb905462 D02

Table 11 Applicability of DFS Requirements Prior to Use of a Channel

Requirement	Operational Mode		
	Master	Client Without Radar Detection	Client With Radar Detection
Non-Occupancy Period	Yes	Not required	Yes
DFS Detection Threshold	Yes	Not required	Yes
Channel Availability Check Time	Yes	Not required	Not required
U-NII Detection Bandwidth	Yes	Not required	Yes

Table 12 Applicability of DFS requirements during normal operation

Requirement	Operational Mode	
	Master Device or Client with Radar Detection	Client Without Radar Detection
DFS Detection Threshold	Yes	Not required
Channel Closing Transmission Time	Yes	Yes
Channel Move Time	Yes	Yes
U-NII Detection Bandwidth	Yes	Not required

Additional requirements for devices with multiple bandwidth modes	Master Device or Client with Radar Detection	Client Without Radar Detection
U-NII Detection Bandwidth and Statistical Performance Check	All BW modes must be tested	Not required
Channel Move Time and Channel Closing Transmission Time	Test using widest BW mode available	Test using the widest BW mode available for the link
All other tests	Any single BW mode	Not required

Note: Frequencies selected for statistical performance check (Section 7.8.4) should include several frequencies within the radar detection bandwidth and frequencies near the edge of the radar detection bandwidth. For 802.11 devices it is suggested to select frequencies in each of the bonded 20 MHz channels and the channel center frequency.

Table 13 Interference Threshold values, Master or Client incorporating In-Service Monitoring

Maximum Transmit Power	Value (See Notes 1, 2, and 3)
EIRP \geq 200 milliwatt	-64 dBm
EIRP < 200 milliwatt and power spectral density < 10 dBm/MHz	-62 dBm
EIRP < 200 milliwatt that do not meet the power spectral density requirement	-64 dBm
<p>Note 1: This is the level at the input of the receiver assuming a 0 dBi receive antenna.</p> <p>Note 2: Throughout these test procedures an additional 1 dB has been added to the amplitude of the test transmission waveforms to account for variations in measurement equipment. This will ensure that the test signal is at or above the detection threshold level to trigger a DFS response.</p> <p>Note3: EIRP is based on the highest antenna gain. For MIMO devices refer to KDB Publication 662911 D01.</p>	

Table 14 DFS Response Requirement Values

Parameter	Value
Non-occupancy period	Minimum 30 minutes
Channel Availability Check Time	60 seconds
Channel Move Time	10 seconds See Note 1.
Channel Closing Transmission Time	200 milliseconds + an aggregate of 60 milliseconds over remaining 10 second period. See Notes 1 and 2
U-NII Detection Bandwidth	Minimum 100% of the U-NII 99% transmission power bandwidth. See Note 3.
<p>Note 1: Channel Move Time and the Channel Closing Transmission Time should be performed with Radar Type 0. The measurement timing begins at the end of the Radar Type 0 burst.</p> <p>Note 2: The Channel Closing Transmission Time is comprised of 200 milliseconds starting at the beginning of the Channel Move Time plus any additional intermittent control signals required to facilitate a Channel move (an aggregate of 60 milliseconds) during the remainder of the 10 second period. The aggregate duration of control signals will not count quiet periods in between transmissions.</p> <p>Note 3: During the U-NII Detection Bandwidth detection test, radar type 0 should be used. For each frequency step the minimum percentage of detection is 90 percent. Measurements are performed with no data traffic.</p>	

Table 15 Short Pulse Radar Test Waveforms

Radar Type	Pulse Width (µsec)	PRI (µsec)	Number of Pulses	Minimum Percentage of Successful Detection	Minimum Number of Trials
0	1	1428	18	See Note 1	See Note 1
1	1	Test A: 15 unique PRI values randomly selected from the list of 23 PRI values in Table 5a	Roundup: $\{(1/360) \times (19 \times 10^6 \text{PRI}_{\mu\text{sec}})\}$	60%	30
		Test B: 15 unique PRI values randomly selected within the range of 518-3066 µsec, with a minimum increment of 1 µsec, excluding PRI values Selected in Test A			
2	1-5	150-230	23-29	60%	30
3	6-10	200-500	16-18	60%	30
4	11-20	200-500	12-16	60%	30
Aggregate (Radar Types 1-4)				80%	120
Note 1: Short Pulse Radar Type 0 should be used for the detection bandwidth test, channel move time, and channel closing time tests.					

Table 16 Long Pulse Radar Test Waveform

Radar Type	Pulse Width (µsec)	Chirp Width (MHz)	PRI (µsec)	Number of Pulses per Burst	Number of Bursts	Minimum Percentage of Successful Detection	Minimum Number of Trials
5	50-100	5-20	1000-2000	1-3	8-20	80%	30

Table 17 Frequency Hopping Radar Test Waveform

Radar Type	Pulse Width (μsec)	PRI (μsec)	Pulses per Hop	Hopping Rate (kHz)	Hopping Sequence Length (msec)	Minimum Percentage of Successful Detection	Minimum Number of Trials
6	1	333	9	0.333	300	70%	30

6.2. TEST PROCEDURE

The EUT Operates over the 5250-5350MHz and 5470-5725 MHz range and it is a Client Device without Radar Detection.

The radar detection threshold, lower antenna gain is the parameter of interference radar DFS detection threshold, the required conducted threshold at the antenna port is the $-62\text{dBm}+0\text{dBi}+1\text{dB}=-61\text{dBm}$.

The R&S SMBV100A vector signal generator with option K350 is used to generate the pulse during test.

The Client device is connected to the Master device on the Channel selected to test. The program iPerf is used to set up a connection between the Client and the Master Device with proper duty cycle.

The Spectrum analyzer is used to monitor the DFS radar pulse and the EUT transmission with zero span function at the selected Channel. The spectrum analyzer is set to peak detection, and max hold.

WLAN traffic load is verified before the pulse is injected.

Channel Move time

The test software controls the spectrum analyzer to start monitoring the EUT transmission, and at $T_0=2\text{sec}$, the pulse is injected. The time the pulse stop is marked as T_1 , The time when no transmission is detected is marked as T_3 . T_3-T_1 is calculated as Channel move time.

Non-Occupancy Period

The test software controls the spectrum analyzer to start monitoring the EUT transmission, and at $T_0=10\text{sec}$, the pulse is injected. T_2 is the channel move time stop moment; the software controls the spectrum to monitor for 1800 seconds. The plot is recorded in report.

6.3. TEST DATA

RADAR WAVEFORM:

Type 0

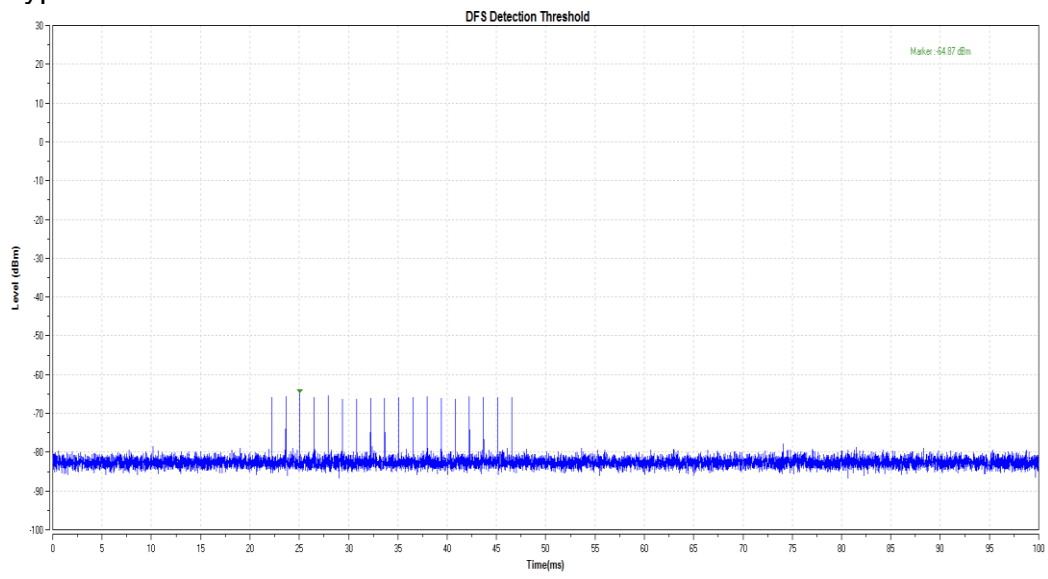

WLAN Traffic

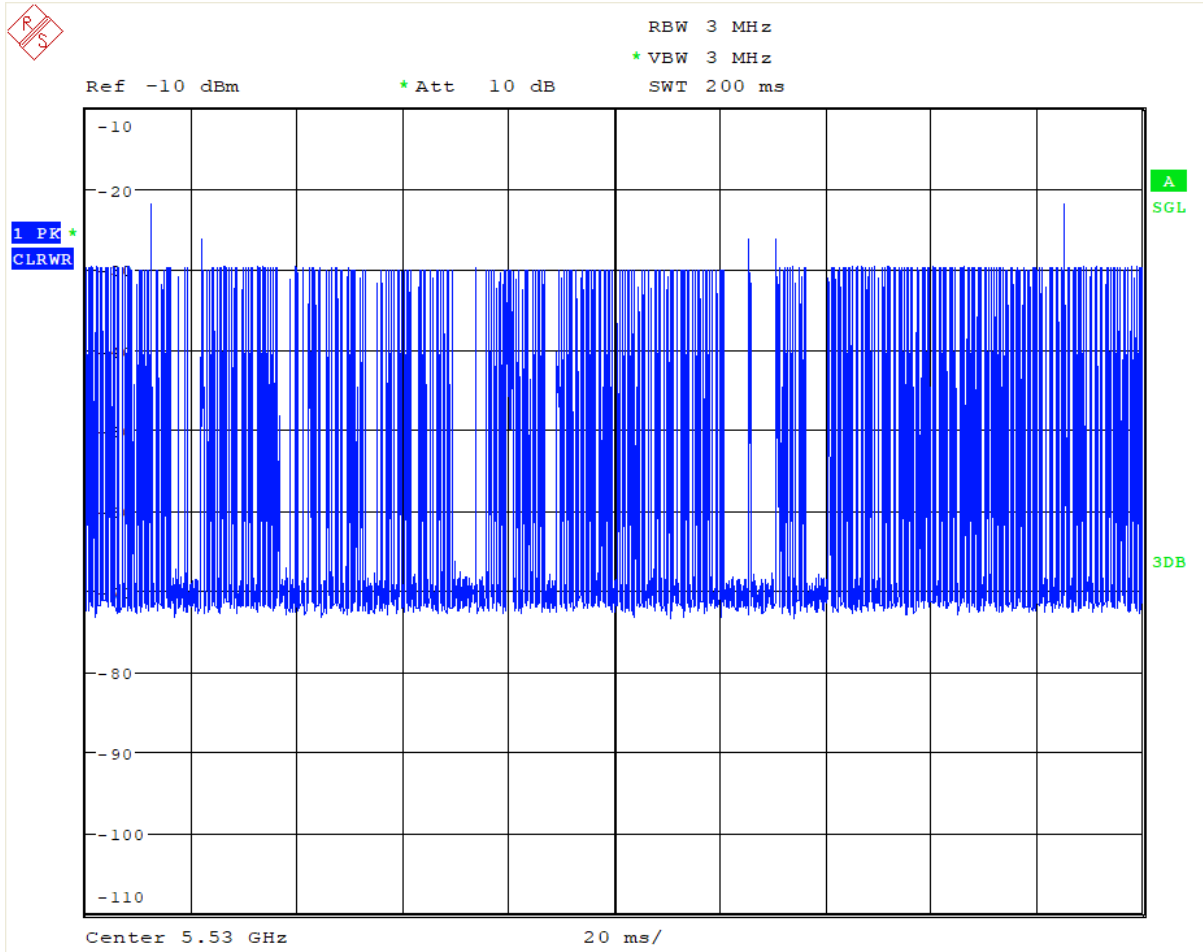

Duty Cycle > 17%

Table 18 Channel Move Time Test Data 802.11ac VHT80

CHANNEL FREQUENCY (MHz)	Channel Move Time(sec)	Limit(sec)	results
5530	0.9981	10	Pass

Table 19 Channel Closing Transmission Time Test Data 802.11ac VHT80

CHANNEL FREQUENCY (MHz)	Channel Closing Transmission Time (millisec)	Limit(millisec)	results
5530	14.3	60	Pass

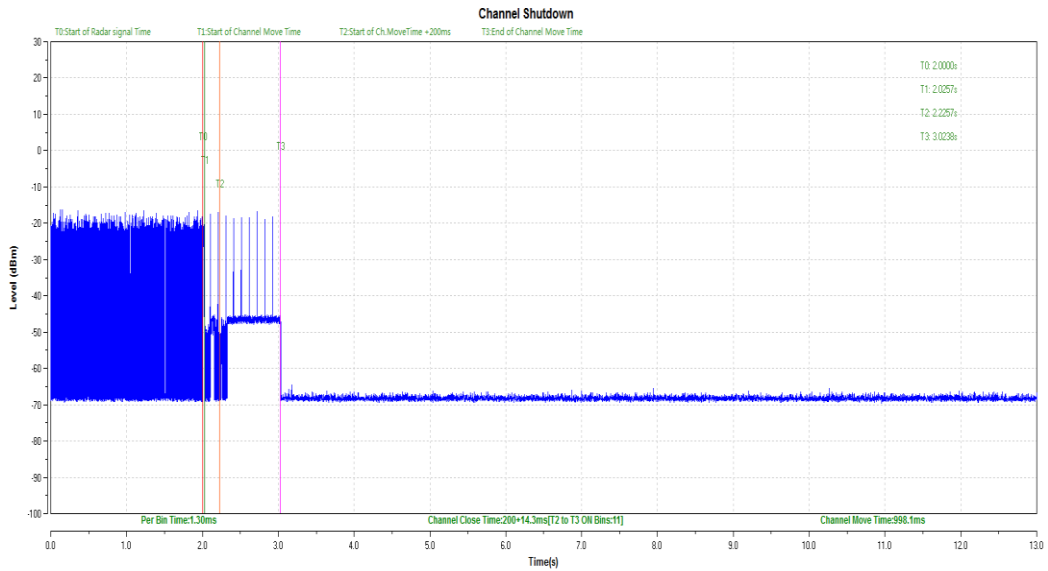

Non-Occupancy Period Test

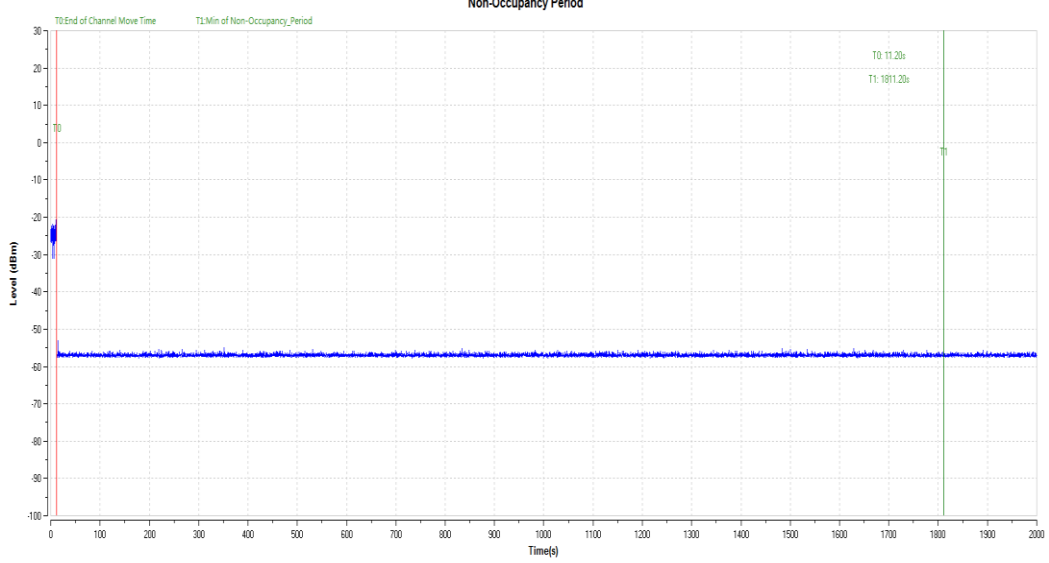

1800s/60=30minute

Verdict : Pass

-----End of Report-----