

FCC Radio Test Report

FCC ID: 2AUYFRMX3286

This report concerns: Original Grant

Project No. : 2110C043A
Equipment : Mobile Phone
Brand Name : realme
Test Model : RMX3286
Series Model : N/A
Applicant : Realme Chongqing Mobile Telecommunications Corp., Ltd.
Address : No.178 Yulong Avenue, Yufengshan, Yubei District, Chongqing, China
Manufacturer : Realme Chongqing Mobile Telecommunications Corp., Ltd.
Address : No.178 Yulong Avenue, Yufengshan, Yubei District, Chongqing, China
Date of Receipt : Oct. 25, 2021
Date of Test : Oct. 26, 2021 ~ Nov. 10, 2021
Issued Date : Dec. 02, 2021
Report Version : R00
Test Sample : Engineering Sample No.: DG20211022140 for conducted, DG20211022142 for radiated.
Standard(s) : 47 CFR FCC Part 90 Subpart S
47 CFR FCC Part 2
ANSI/TIA/EIA-603-E-2016
FCC KDB 971168 D01 Power Meas License Digital Systems v03r01

The above equipment has been tested and found compliance with the requirement of the relative standards by BTL Inc.

Gabriel Zhu

Prepared by : Gabriel Zhu

Steven Lu

Approved by : Steven Lu



TESTING CERT #5123.02

Add: No. 3 Jinshagang 1st Rd. Shixia, Dalang Town, Dongguan City, Guangdong, People's Republic of China

Tel: +86-769-8318-3000

Web: www.newbtl.com

Declaration

BTL represents to the client that testing is done in accordance with standard procedures as applicable and that test instruments used has been calibrated with standards traceable to international standard(s) and/or national standard(s).

BTL's reports apply only to the specific samples tested under conditions. It is manufacture's responsibility to ensure that additional production units of this model are manufactured with the identical electrical and mechanical components. **BTL** shall have no liability for any declarations, inferences or generalizations drawn by the client or others from **BTL** issued reports.

The report must not be used by the client to claim product certification, approval, or endorsement by NIST, A2LA, or any agency of the U.S. Government.

This report is the confidential property of the client. As a mutual protection to the clients, the public and ourselves, the test report shall not be reproduced, except in full, without our written approval.

BTL's laboratory quality assurance procedures are in compliance with the **ISO/IEC 17025** requirements, and accredited by the conformity assessment authorities listed in this test report.

BTL is not responsible for the sampling stage, so the results only apply to the sample as received.

The information, data and test plan are provided by manufacturer which may affect the validity of results, so it is manufacturer's responsibility to ensure that the apparatus meets the essential requirements of applied standards and in all the possible configurations as representative of its intended use.

Limitation

For the use of the authority's logo is limited unless the Test Standard(s)/Scope(s)/Item(s) mentioned in this test report is (are) included in the conformity assessment authorities acceptance respective.

Please note that the measurement uncertainty is provided for informational purpose only and is not use in determining the Pass/Fail results.

Table of Contents	Page
REPORT ISSUED HISTORY	5
1 . SUMMARY OF TEST RESULTS	6
1.1 TEST FACILITY	7
1.2 MEASUREMENT UNCERTAINTY	7
1.3 TEST ENVIRONMENT CONDITIONS	7
2 . GENERAL INFORMATION	8
2.1 GENERAL DESCRIPTION OF EUT	8
2.2 DESCRIPTION OF TEST MODES	10
2.3 BLOCK DIGRAM SHOWING THE CONFIGURATIONOFSYSTEMTESTED	11
2.4 DESCRIPTION OF SUPPORT UNITS	11
3 . TEST RESULT	12
3.1 OUTPUT POWER MEASUREMENT	12
3.1.1 LIMIT	12
3.1.2 TEST PROCEDURE	12
3.1.3 TESTSETUP LAYOUT	12
3.1.4 TEST DEVIATION	12
3.1.5 TEST RESULTS	12
3.2 OCCUPIED BANDWIDTH MEASUREMENT	13
3.2.1 TEST PROCEDURE	13
3.2.2 TEST SETUP LAYOUT	13
3.2.3 TEST DEVIATION	13
3.2.4 TEST RESULTS	13
3.3 CONDUCTED SPURIOUS EMISSIONS MEASUREMENT	14
3.3.1 LIMIT	14
3.3.2 TEST PROCEDURES	14
3.3.3 TESTSETUP LAYOUT	14
3.3.4 TESTDEVIATION	14
3.3.5 TEST RESULTS	14
3.4 RADIATED SPURIOUS EMISSIONS MEASUREMENT	15
3.4.1 LIMIT	15
3.4.2 TEST PROCEDURES	15
3.4.3 TEST SETUP LAYOUT	16
3.4.4 TESTDEVIATION	17
3.4.5 TEST RESULTS (9KHZ TO 30MHZ)	17
3.4.6 TEST RESULTS (30MHZ TO 1000MHZ)	17
3.4.7 TEST RESULTS (ABOVE 1000MHZ)	17
3.5 MASK MEASUREMENTS	18
3.5.1 LIMIT	18

Table of Contents	Page
3.5.2 TEST PROCEDURES	18
3.5.3 TESTSETUP LAYOUT	18
3.5.4 TESTDEVIATION	18
3.5.5 TEST RESULTS	18
3.6 PEAK TO AVERAGE RATIO MEASUREMENT	19
3.6.1 LIMIT	19
3.6.2 TEST PROCEDURES	19
3.6.3 TEST SETUP LAYOUT	19
3.6.4 TEST DEVIATION	19
3.6.5 TEST RESULTS	19
3.7 FREQUENCY STABILITY MEASUREMENT	20
3.7.1 LIMIT	20
3.7.2 TEST PROCEDURES	20
3.7.3 TESTSETUP LAYOUT	20
3.7.4 TESTDEVIATION	20
3.7.5 TEST RESULTS	20
5. LIST OF MEASUREMENT EQUIPMENTS	21
APPENDIX A - OUTPUT POWER	23
APPENDIX B - OCCUPIED BANDWIDTH	32
APPENDIX C - CONDUCTED SPURIOUS EMISSIONS	43
APPENDIX D - RADIATED SPURIOUS EMISSIONS (9KHZ TO 30MHZ)	47
APPENDIX E - RADIATED SPURIOUS EMISSIONS (30MHZ TO 1000MHZ)	52
APPENDIX F - RADIATED SPURIOUS EMISSIONS (ABOVE 1000MHZ)	59
APPENDIX G - MASK	66
APPENDIX H - PEAK TO AVERAGE RATIO	71
APPENDIX I - FREQUENCY STABILITY	79

1. SUMMARY OF TEST RESULTS

Test procedures according to the technical standard(s):

FCC Part 90 Subpart S & Part 2			
Standard(s) Section	Test Item	Judgment	Remark
2.1046 & 90.635 (b)	Effective Radiated Power	PASS	-----
2.1049 & 90.209	Occupied Bandwidth	PASS	-----
2.1053 & 90.669	Conducted Spurious Emissions	PASS	-----
2.1053 & 90.669	Radiated Spurious Emissions	PASS	-----
2.1053 & 90.691	Mask Measurements	PASS	-----
-	Peak To Average Ratio	PASS	Record Only
2.1055 & 90.213	Frequency Stability	PASS	-----

Note:

(1) "N/A" denotes test is not applicable in this test report.

REPORT ISSUED HISTORY

Report Version	Description	Issued Date
R00	Original Issue.	Dec. 02, 2021

1.1 TEST FACILITY

The test facilities used to collect the test data in this report is at the location of No. 3 Jinshagang 1st Rd. Shixia, Dalang Town, Dongguan City, Guangdong, People's Republic of China.

BTL's Test Firm Registration Number for FCC: 357015

BTL's Designation Number for FCC: CN1240

1.2 MEASUREMENT UNCERTAINTY

ISO/IEC 17025 requires that an estimate of the measurement uncertainties associated with the emissions test results be included in the report. The measurement uncertainties given below are based on a 95% confidence level (based on a coverage factor (k=2))

The BTL measurement uncertainty as below table:

A. Radiated Measurement :

Test Site	Method	Measurement Frequency Range	Ant. H / V	U,(dB)
DG-CB03	CISPR	9KHz ~ 30MHz	-	2.36
		30MHz ~ 200MHz	V	4.36
		30MHz ~ 200MHz	H	3.32
		200MHz ~ 1,000MHz	V	4.08
		200MHz ~ 1,000MHz	H	3.96
		1GHz ~ 6GHz	-	3.80
		6GHz ~ 18GHz	-	4.82

B. Other Measurement:

Parameter	Uncertainty
Spectrum Bandwidth	±3.8 %
Maximum Output Power	±0.95 dB
Power Spectral Density	±0.86 dB
Frequency Stability	±0.16 dB
Temperature	±0.08 °C
Time	±0.58 %
Supply voltages	±0.3 %

Note: Unless specifically mentioned, the uncertainty of measurement has not been taken into account to declare the compliance or non-compliance to the specification.

1.3 TEST ENVIRONMENT CONDITIONS

Test Item	Temperature	Humidity	Test Voltage	Tested By
Output Power & ERP	22.4°C	48%	DC 3.87V	Rick Liao
Occupied Bandwidth	22.4°C	48%	DC 3.87V	Rick Liao
Conducted Spurious Emissions	22.4°C	48%	DC 3.87V	Rick Liao
Radiated Spurious Emissions	26°C	52%	AC 120V/60Hz	Kwok Guo
Band Edge	22.4°C	48%	DC 3.87V	Rick Liao
Peak To Average Ratio	22.4°C	48%	DC 3.87V	Rick Liao
Frequency Stability	Normal & Extreme	48%	Normal & Extreme	Rick Liao

2. GENERAL INFORMATION

2.1 GENERAL DESCRIPTION OF EUT

Equipment	Mobile Phone				
Brand Name	realme				
Test Model	RMX3286				
Series Model	N/A				
Model Difference(s)	N/A				
Hardware Version	11				
Software Version	realme UI V2.0				
Power Source	1# DC voltage supplied from AC adapter. (1) Model: VCB3HDUH (2) Model: VCB3HAUH 2# Supplied from battery. Model: BLP875 3# Supplied from USB port.				
Power Rating	1# I/P: 100-240V~ 50/60Hz 1.2A O/P: 5V \equiv 2A or 5-11V \equiv 3A Max 2# DC 3.87V, 4880mAh 3# DC 5V				
IEMI No.	Radiated	860074050019375			
	Conducted	860074050019359			
Modulation Type	LTE	UL: QPSK,16QAM,64QAM DL: QPSK,16QAM,64QAM,256QAM			
Max. ERP	LTE	Channel Bandwidth (MHz)	QPSK (dBm)	16QAM (dBm)	64QAM (dBm)
		1.4	21.71	20.97	20.14
	Band 26	3	21.57	20.95	19.96
		5	21.86	21.31	20.14
		10	21.79	21.16	19.92

Note:

1. For a more detailed features description, please refer to the manufacturer's specifications or the user's manual.

2. Channel List:

LTE Band 26					
Test Frequency ID	Bandwidth (MHz)	N _{UL}	Frequency of Uplink (MHz)	N _{DL}	Frequency of Downlink (MHz)
Low Range	1.4	26697	814.7	8697	859.7
	3	26705	815.5	8705	860.5
	5	26715	816.5	8715	861.5
Mid Range	1.4/3/5/10	26740	819	8740	864
High Range	1.4	26783	823.3	8783	868.3
	3	26775	822.5	8775	867.5
	5	26765	821.5	8765	866.5

3. Table for Filed Antenna:

Main Antenna

Brand	Model Name	Antenna Type	Connector	Gain (dBi)	Note
N/A	N/A	PIFA	N/A	0.5	LTE Band 26

Second Antenna

Brand	Model Name	Antenna Type	Connector	Gain (dBi)	Note
N/A	N/A	PIFA	N/A	0.5	LTE Band 26

Note: The antenna gain is provided by the manufacturer.

2.2 DESCRIPTION OF TEST MODES

Following mode(s) is (were) found to be the worst case(s) and selected for the final test.

LTE BAND 26 MODE					
Test Item	Available Channel	Tested Channel	Channel Bandwidth	Modulation	Mode
Output Power & ERP	26697 to 26783	26697, 26740, 26783	1.4MHz	QPSK, 16QAM, 64QAM	1RB/3RB/6RB
	26705 to 26775	26705, 26740, 26775	3MHz	QPSK, 16QAM, 64QAM	1RB/8RB/15RB
	26715 to 26765	26715, 26740, 26765	5MHz	QPSK, 16QAM, 64QAM	1RB/12RB/25RB
	26740	26740	10MHz	QPSK, 16QAM, 64QAM	1RB/25RB/50RB
Occupied Bandwidth	26697 to 26783	26697, 26740, 26783	1.4MHz	QPSK, 16QAM, 64QAM	6RB
	26705 to 26775	26705, 26740, 26775	3MHz	QPSK, 16QAM, 64QAM	15RB
	26715 to 26765	26715, 26740, 26765	5MHz	QPSK, 16QAM, 64QAM	25RB
	26740	26740	10MHz	QPSK, 16QAM, 64QAM	50RB
Conducted Spurious Emissions	26697 to 26783	26740	1.4MHz	QPSK	1RB
	26705 to 26775	26740	5MHz	QPSK	1RB
	26715 to 26765	26740	10MHz	QPSK	1RB
Radiated Spurious Emissions	26697 to 26783	26740	1.4MHz	QPSK	1RB
	26705 to 26775	26740	5MHz	QPSK	1RB
	26715 to 26765	26740	10MHz	QPSK	1RB
Mask	26697 to 26783	26697, 26783	1.4MHz	QPSK	1RB 6RB
	26705 to 26775	26705, 26775	3MHz	QPSK	1RB 15RB
	26715 to 26765	26715, 26765	5MHz	QPSK	1RB 25RB
	26740	26740	10MHz	QPSK	1RB
					50RB
Peak To Average Ratio	26697 to 26783	26697, 26740, 26783	1.4MHz	QPSK, 16QAM, 64QAM	1RB
	26705 to 26775	26705, 26740, 26775	3MHz	QPSK, 16QAM, 64QAM	1RB
	26715 to 26765	26715, 26740, 26765	5MHz	QPSK, 16QAM, 64QAM	1RB
	26740	26740	10MHz	QPSK, 16QAM, 64QAM	1RB
Frequency Stability	26697 to 26783	26740	1.4MHz	QPSK	1RB
	26705 to 26775	26740	3MHz	QPSK	1RB
	26715 to 26765	26740	5MHz	QPSK	1RB
	26740	26740	10MHz	QPSK	1RB

2.3 BLOCK DIGRAM SHOWING THE CONFIGURATION OF SYSTEM TESTED

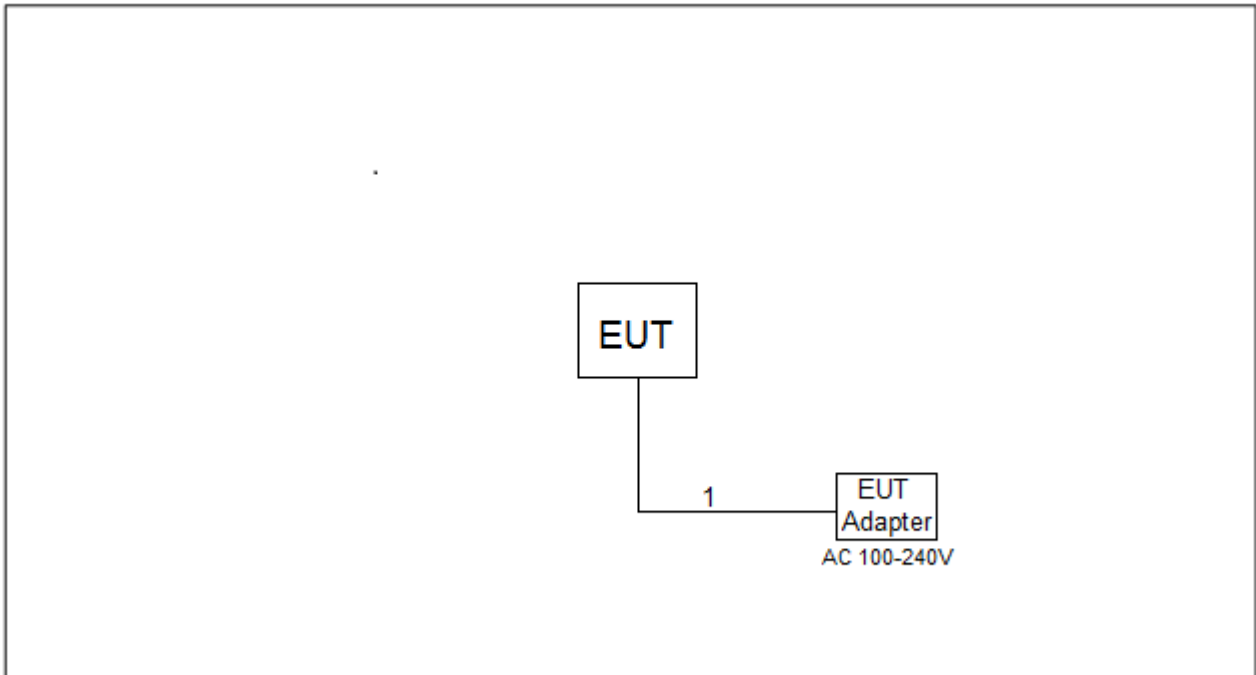

2.4 DESCRIPTION OF SUPPORT UNITS

The EUT has been tested as an independent unit together with other necessary accessories or support units. The following support units or accessories were used to form a representative test configuration during the tests.

Item	Equipment	Mfr/Brand	Model/Type No.	Series No.
-	-	-	-	-

Item	Cable Type	Shielded Type	Ferrite Core	Length
1	USB Cable	NO	NO	1m

3. TEST RESULT

3.1 OUTPUT POWER MEASUREMENT

3.1.1 LIMIT

Mobile / Portable station are limited to 100 watts e.r.p.

3.1.2 TEST PROCEDURE

The testing follows FCC KDB 971168 v03r01 Section 5.0.

ERP:

$EIRP = \text{Output Power} + \text{Antenan gain}$

$ERP = EIPR - 2.15dBi.$

Output Power:

The EUT was set up for the maximum power with GSM, GPRS, EDGE, WCDMA, CDMA, and LTE link data modulation and link up with simulator. Set the EUT to transmit under low, middle and high channel and record the power level shown on simulator.

3.1.3 TESTSETUP LAYOUT

Output Power Measurement

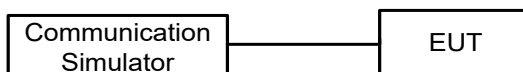

3.1.4 TEST DEVIATION

No deviation

3.1.5 TEST RESULTS

Please refer to the APPENDIX A.

3.2 OCCUPIED BANDWIDTH MEASUREMENT

3.2.1 TEST PROCEDURE

The testing follows FCC KDB 971168 v03r01 Section 4.0.

1. The EUT makes a call to the communication simulator. All measurements were done at low, middle and high operational frequency range. The communication simulator station system controlled a EUT to export maximum output power under transmission mode and specific channel frequency. Use OBW measurement function of Spectrum analyzer to measure 99 % occupied bandwidth and 26dB bandwidth.
2. The EUT was connected to spectrum analyzer and system simulator via a power divider.
3. $RBW = (1\% \sim 5\%) * EBW$
 $VBW \geq 3 * RBW$
4. Set spectrum analyzer with RMS detector.

3.2.2 TEST SETUP LAYOUT

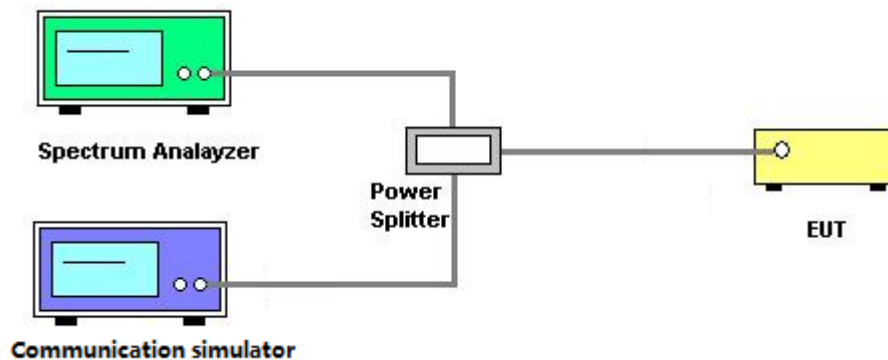

3.2.3 TEST DEVIATION

No deviation

3.2.4 TEST RESULTS

Please refer to the APPENDIX B.

3.3 CONDUCTED SPURIOUS EMISSIONS MEASUREMENT

3.3.1 LIMIT

The power of any emission outside of the authorized operating frequency ranges must be attenuated below the transmitting power (P) by a factor of at least $43 + 10 \log(P)$ dB. The emission limit equal to -13dBm.

3.3.2 TEST PROCEDURES

The testing follows FCC KDB 971168 v03r01 Section 6.0.

1. The EUT was connected to spectrum analyzer and system simulator via a power divider.
2. The band edges of low and high channels for the highest RF powers were measured. Set RBW \geq 1% EBW in the 1MHz band immediately outside and adjacent to the band edge.
3. Set spectrum analyzer with RMS detector.
4. The RF fundamental frequency should be excluded against the limit line in the operating frequency band.

3.3.3 TESTSETUP LAYOUT

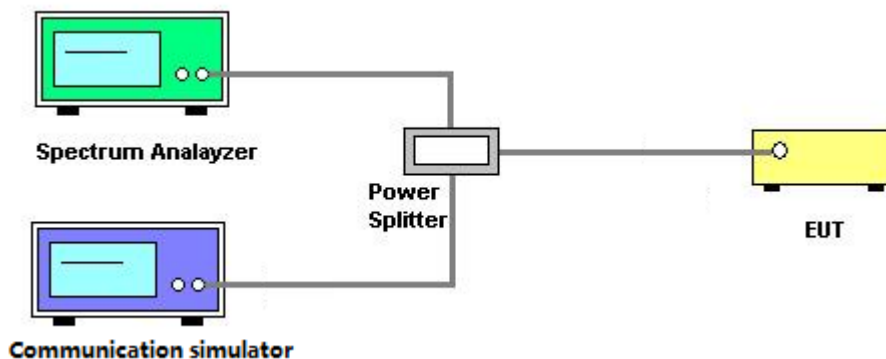

3.3.4 TESTDEVIATION

No deviation

3.3.5 TEST RESULTS

Please refer to the APPENDIX C.

3.4 RADIATED SPURIOUS EMISSIONS MEASUREMENT

3.4.1 LIMIT

The power of any emission outside of the authorized operating frequency ranges must be attenuated below the transmitting power (P) by a factor of at least $43 + 10 \log(P)$ dB. The emission limit equal to -13dBm.

3.4.2 TEST PROCEDURES

The testing follows FCC KDB 971168 v03r01 Section 5.8.

1. In the semi-anechoic chamber, EUT placed on the 0.8m height of Turn Table, rotated the table around 360 degrees to search the maximum radiation power and receiver antenna shall be rotated vertical and horizontal polarization and moved height from 1m to 4m to find the maximum polar radiated power. The "Read Value" is the spectrum reading the maximum power value.
2. The substitution horn antenna is substituted for EUT at the same position and signals generator export the CW signal to the substitution antenna via a TX cable. Rotated the Turn Table and moved receiving antenna to find the maximum radiation power. Adjust output power level of S.G to get a Value of spectrum reading equal to "Read Value " of step a. Record the power level of S.G
3. $EIRP = \text{Output power level of S.G} - \text{TX cable loss} + \text{Antenna gain of substitution horn.}$
4. ERP can be calculated form EIRP by subtracting the gain of dipole, $ERP = EIPR - 2.15dBi.$
5. The resolution bandwidth and video bandwidth of test receiver/spectrum analyzer is 1MHz/3MHz.

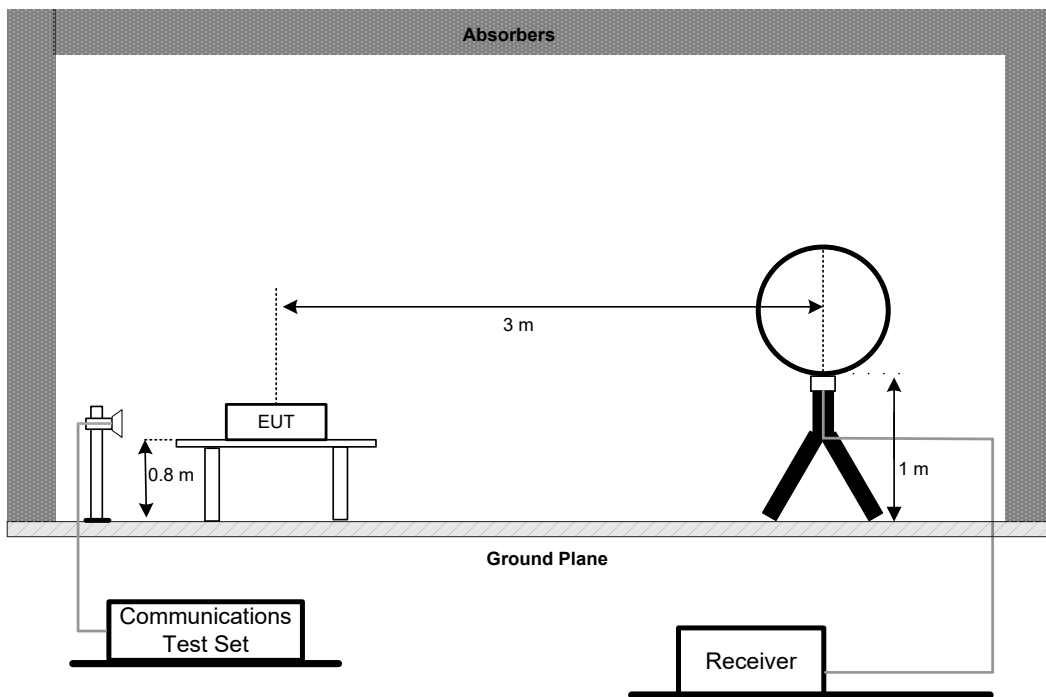
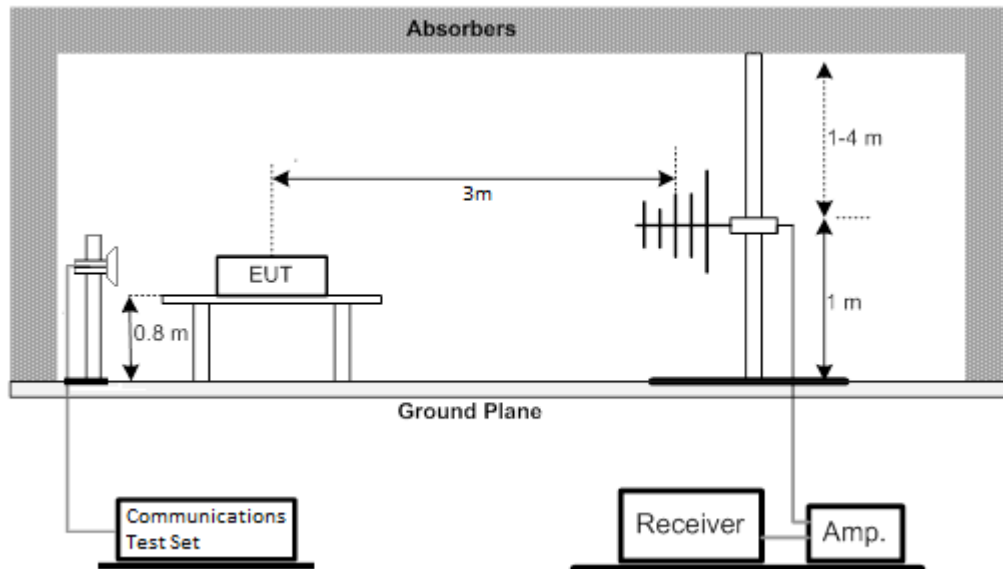
3.4.3 TEST SETUP LAYOUT**Below 30MHz****30MHz to 1000MHz**

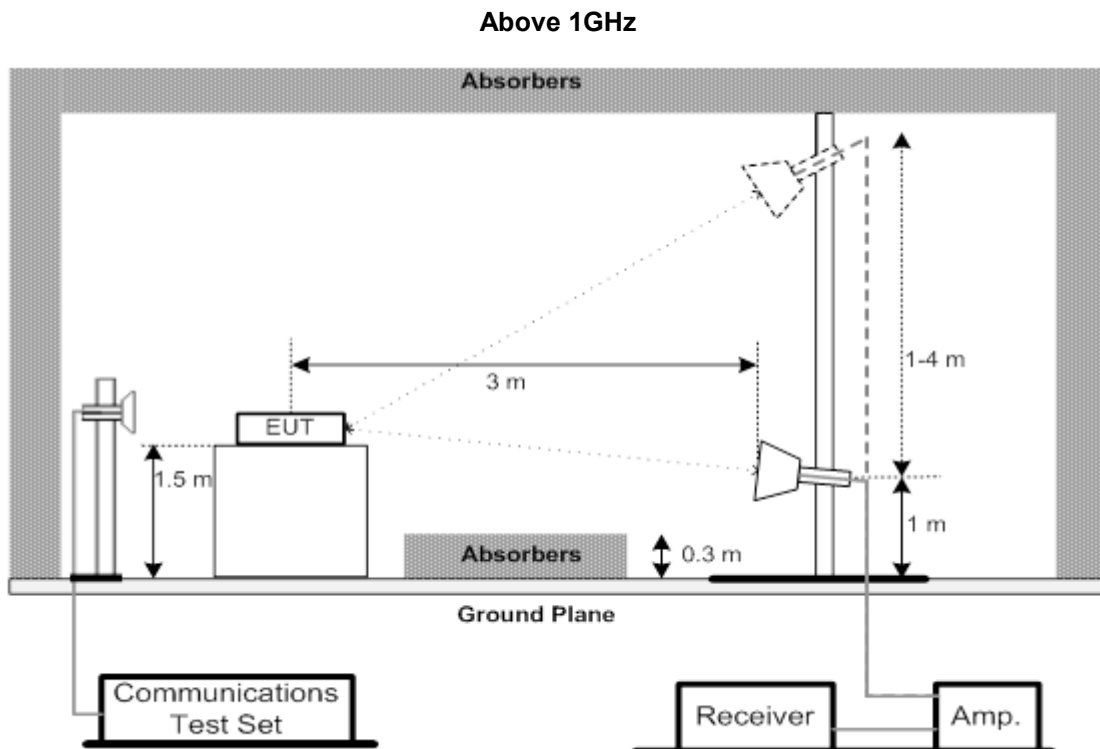

3.4.4 TESTDEVIATION

No deviation

3.4.5 TEST RESULTS (9KHZ TO 30MHZ)

Please refer to the APPENDIX D.

3.4.6 TEST RESULTS (30MHZ TO 1000MHZ)

Please refer to the APPENDIX E.

3.4.7 TEST RESULTS (ABOVE 1000MHZ)

Please refer to the APPENDIX F.

3.5 MASK MEASUREMENTS

3.5.1 LIMIT

According to FCC part 90.691 shall be tested the emission mask. For any frequency removed from the EA licensee's frequency block by up to and including 37.5 kHz, the power of any emission shall be attenuated below the transmitter power (P) in watts by at least $116 \text{ Log}_{10}(f/6.1)$ decibels or $50+10\text{Log}_{10}(P)$ decibels or 80 decibels, whichever is the lesser attenuation, where f is the frequency removed from the center of the outer channel in the block in kilohertz and where f is greater than 12.5 kHz. For any frequency removed from the EA licensee's frequency block greater than 37.5 kHz, the power of any emission shall be attenuated below the transmitter power (P) in watts by at least $43 + 10\text{Log}_{10}(P)$ decibels or 80 decibels, whichever is the lesser attenuation, where f is the frequency removed from the center of the outer channel in the block in kilohertz and where f is greater than 37.5 kHz.

3.5.2 TEST PROCEDURES

The testing follows FCC KDB 971168 v03r01 Section 6.0.

1. All measurements were done at low and high operational frequency range.
2. Set RBW=1% of 26dBc bandwidth, VBW=3 X RBW, detector=RMS, Sweep time = Auto.
For Section 90.691(a) compliance testing, use RBW = 300 Hz for offsets less than 37.5 kHz from a channel edge; RBW = 100 kHz for offsets greater than 37.5 kHz is allowed.
3. Record the max trace plot into the test report.

3.5.3 TESTSETUP LAYOUT

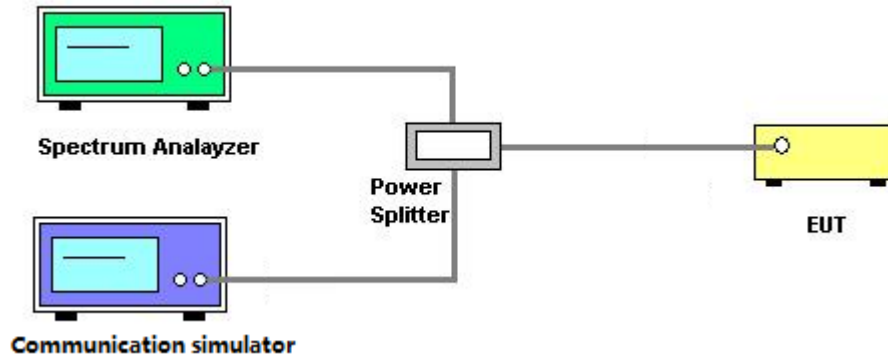

3.5.4 TESTDEVIATION

No deviation

3.5.5 TEST RESULTS

Please refer to the APPENDIX G.

3.6 PEAK TO AVERAGE RATIO MEASUREMENT

3.6.1 LIMIT

In measuring transmissions in this band using an average power technique, the peak to-average ratio (PAR) of the transmission may not exceed 13 dB.

3.6.2 TEST PROCEDURES

The testing follows FCC KDB 971168 v03r01 Section 5.7.

1. Set resolution/measurement bandwidth \geq signal's occupied bandwidth;
2. Set the number of counts to a value that stabilizes the measured CCDF curve;
3. Record the maximum PAPR level associated with a probability of 0.1%.

3.6.3 TEST SETUP LAYOUT

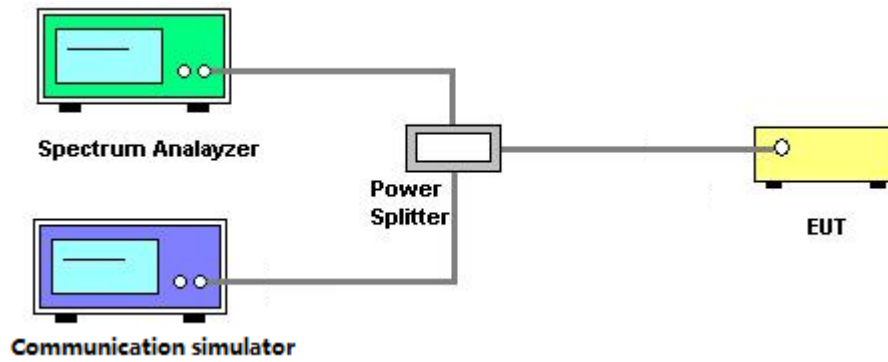

3.6.4 TEST DEVIATION

No deviation

3.6.5 TEST RESULTS

Please refer to the APPENDIX H.

3.7 FREQUENCY STABILITY MEASUREMENT

3.7.1 LIMIT

± 1.5 ppm is for base and fixed station. ± 2.5 ppm is for mobile station.

3.7.2 TEST PROCEDURES

The testing follows FCC KDB 971168 v03r01 Section 9.0.

1. Device is placed at the oven room. The oven room could control the temperatures and humidity. Power warm up is at least 15 min and power applied should perform before recording frequency error.
2. EUT is connected the external power supply to control the DC input power. The test voltage range is from minimum to maximum working voltage. Each step shall be record the frequency error rate.
3. The temperature range step is 10 degrees in this test items. All temperature levels shall be hold the $\pm 0.5^{\circ}\text{C}$ during the measurement testing. The each temperature step shall be at least 0.5 hours, consider the EUT could be test under the stability condition.
4. The frequency error was recorded frequency error from the communication simulator.

3.7.3 TESTSETUP LAYOUT

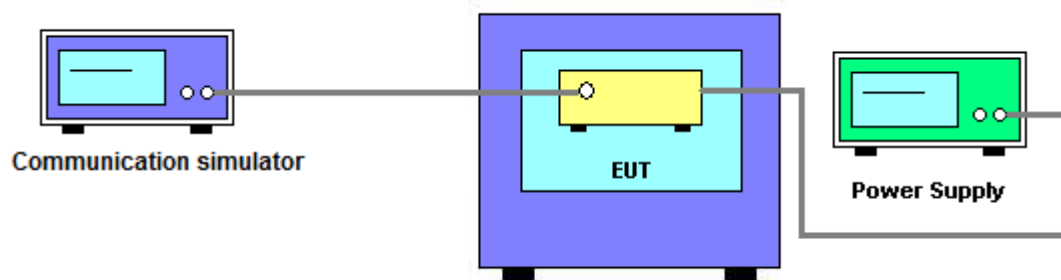

3.7.4 TESTDEVIATION

No deviation

3.7.5 TEST RESULTS

Please refer to the APPENDIX I.

5. LIST OF MEASUREMENT EQUIPMENTS

Radiated Spurious Emission Measurement					
Item	Kind of Equipment	Manufacturer	Type No.	Serial No.	Calibrated until
1	Antenna	Schwarzbeck	VULB9160	9160-3231	Apr. 14, 2022
2	Amplifier	Agilent	8449B	3008A02334	Feb. 27, 2022
3	HighPass Filter	Wairwright Instruments Gmbh	WHK 1.5/15G-10ST	11	Feb. 27, 2022
4	Band Reject Filter	Wairwright Instruments Gmbh	WRCG 1710/1785-1690/1805-60/ 12SS	38	Feb. 27, 2022
5	Band Reject Filter	Wairwright Instruments Gmbh	WRCG 824/849-810/863-60/9SS	7	Feb. 27, 2022
6	Band Reject Filter	Wairwright Instruments Gmbh	WRCG 880/915-860/935-60/9SS	14	Feb. 27, 2022
7	Band Reject Filter	Wairwright Instruments Gmbh	WRCG 1850/1910-1830/1930-60/ 10SS	17	Feb. 27, 2022
8	HighPass Filter	Wairwright Instruments Gmbh	WHK3.1/18G-10SS	24	Feb. 27, 2022
9	Wireless Communication Test SET	Agilent	E5515C	MY48364183	Feb. 28, 2022
10	Microwave Preamplifier With Adaptor	EMC INSTRUMENT	EMC2654045	980039 & HA01	Feb. 28, 2022
11	Receiver	Agilent	N9038A	MY52130039	Mar. 19, 2022
12	wideband radio communication tester	R&S	CMW500	152372	Feb. 27, 2022
13	High pass filter	KANGMAIWEI	ZHPF-M3-12.75G-3869	B2015073763	Feb. 07, 2022
14	High pass filter	KANGMAIWEI	ZHPF-M1000-4000-1	B2015073762	Feb. 07, 2022
15	High pass filter	KANGMAIWEI	ZHPF-M6-186-1727	B2015073764	Feb. 07, 2022
16	Cable	emci	LMR-400(30MHz-1GHz) (8m+5m)	N/A	May 20, 2022
17	Cable	mitron	RWLP50-4.0A-KJ-SMSM-12M	N/A	Nov. 23, 2021
18	Controller	ETS-Lindgren	2090	N/A	N/A
19	Measurement Software	Farad	EZ-EMC Ver.NB-03A1-01	N/A	N/A
20	Antenna	EM	EM-6876-1	230	Apr. 28, 2022
21	Double Ridged Guide Antenna	ETS	3115	75846	Mar. 17, 2022
22	Broad-Band Horn Antenna	Schwarzbeck	BBHA 9170	9170319	Jun. 30, 2022

Conducted Measurement					
Item	Kind of Equipment	Manufacturer	Type No.	Serial No.	Calibrated until
1	8960 Series 10 Wireless Com Test set	Agilent	E5515E	MY52112163	Jul. 24, 2022
2	MXA Signal Analyzer	Keysight	N9020A	MY49100060	Jul. 24, 2022
3	Power Splitter	Mini-Circuits	ZFRSC-183-S+	SF103501511S	Jul. 24, 2022
4	wideband radio communication tester	R&S	CMW500	104462	Jul. 24, 2022
5	Const Temp. & Humi dity Chamber	Bell	BTH-50C	20170306001	Feb. 27, 2022
6*	Multi-output DC Power Supply	GW Instek	GPC-3030DN	EK880675	Jul. 25, 2023

Remark: "N/A" denotes no model name, serial no. or calibration specified.

Except * item, all calibration period of equipment list is one year.

"*" calibration period of equipment list is three year.

APPENDIX A - OUTPUT POWER

Output Power For Main Antenna (dBm):

LTE Band / BW	Modulation	RB Size	RB Offset	Low CH	Mid CH	High CH
				26697CH	26740CH	26783CH
				814.7MHz	819MHz	823.3MHz
26 / 1.4M	QPSK	1	0	23.25	23.13	23.16
		1	2	23.31	23.19	23.23
		1	5	23.21	23.11	23.18
		3	0	23.33	23.28	23.25
		3	1	23.36	23.30	23.25
		3	2	23.30	23.28	23.24
	6	0	22.36	22.34	22.33	
	16QAM	1	0	22.33	22.57	22.20
		1	2	22.38	22.62	22.22
		1	5	22.28	22.55	22.23
		3	0	22.37	22.52	22.45
		3	1	22.37	22.49	22.48
		3	2	22.37	22.50	22.47
	6	0	21.52	21.26	21.52	
	64QAM	1	0	21.49	21.48	21.69
		1	2	21.58	21.52	21.79
		1	5	21.43	21.53	21.68
		3	0	21.58	21.35	21.73
		3	1	21.61	21.36	21.74
		3	2	21.58	21.37	21.70
	6	0	20.76	20.49	20.40	

LTE Band / BW	Modulation	RB Size	RB Offset	Low CH	Mid CH	High CH
				26705CH	26740CH	26775CH
				815.5MHz	819MHz	822.5MHz
26 / 3M	QPSK	1	0	23.06	23.01	23.09
		1	7	23.15	23.15	23.22
		1	14	23.03	23.01	23.10
		8	0	22.30	22.26	22.25
		8	4	22.35	22.31	22.29
		8	7	22.28	22.23	22.23
		15	0	22.24	22.25	22.22
	16QAM	1	0	22.49	22.14	21.96
		1	7	22.60	22.25	22.11
		1	14	22.45	22.10	21.93
		8	0	21.40	21.30	21.37
		8	4	21.47	21.39	21.43
		8	7	21.41	21.33	21.35
		15	0	21.29	21.24	21.30
	64QAM	1	0	21.31	21.39	21.50
		1	7	21.47	21.50	21.61
		1	14	21.32	21.36	21.48
		8	0	20.41	20.33	20.44
		8	4	20.47	20.37	20.47
		8	7	20.41	20.29	20.38
		15	0	20.40	20.34	20.32

LTE Band / BW	Modulation	RB Size	RB Offset	Low CH	Mid CH	High CH
				26715CH	26740CH	26765CH
				816.5MHz	819MHz	821.5MHz
26 / 5M	QPSK	1	0	23.36	23.39	23.28
		1	13	23.50	23.51	23.40
		1	24	23.33	23.35	23.30
		12	0	22.29	22.27	22.25
		12	6	22.38	22.35	22.33
		12	11	22.40	22.36	22.35
		25	0	22.36	22.36	22.33
	16QAM	1	0	22.84	22.42	22.46
		1	13	22.96	22.54	22.59
		1	24	22.80	22.43	22.46
		12	0	21.44	21.35	21.38
		12	6	21.56	21.43	21.46
		12	11	21.57	21.45	21.49
		25	0	21.45	21.33	21.37
	64QAM	1	0	21.65	21.56	21.27
		1	13	21.79	21.71	21.37
		1	24	21.64	21.61	21.28
		12	0	20.33	20.44	20.38
		12	6	20.44	20.54	20.50
		12	11	20.45	20.54	20.51
		25	0	20.42	20.49	20.38

LTE Band / BW	Modulation	RB Size	RB Offset	Mid CH
				26740CH
				819MHz
26 / 10M	QPSK	1	0	23.44
		1	25	23.44
		1	49	23.39
		25	0	22.25
		25	13	22.41
		25	25	22.42
		50	0	22.29
	16QAM	1	0	22.77
		1	25	22.81
		1	49	22.73
		25	0	21.28
		25	13	21.47
		25	25	21.45
		50	0	21.42
	64QAM	1	0	21.57
		1	25	21.57
		1	49	21.51
		25	0	20.42
		25	13	20.59
		25	25	20.58
		50	0	20.51

ERP For Main Antenna (dBm):

LTE Band / BW	Modulation	RB Size	RB Offset	Low CH	Mid CH	High CH
				26697CH	26740CH	26783CH
				814.7MHz	819MHz	823.3MHz
26 / 1.4M	QPSK	1	0	21.60	21.48	21.51
		1	2	21.66	21.54	21.58
		1	5	21.56	21.46	21.53
		3	0	21.68	21.63	21.60
		3	1	21.71	21.65	21.60
		3	2	21.65	21.63	21.59
		6	0	20.71	20.69	20.68
	16QAM	1	0	20.68	20.92	20.55
		1	2	20.73	20.97	20.57
		1	5	20.63	20.90	20.58
		3	0	20.72	20.87	20.80
		3	1	20.72	20.84	20.83
		3	2	20.72	20.85	20.82
		6	0	19.87	19.61	19.87
	64QAM	1	0	19.84	19.83	20.04
		1	2	19.93	19.87	20.14
		1	5	19.78	19.88	20.03
		3	0	19.93	19.70	20.08
		3	1	19.96	19.71	20.09
		3	2	19.93	19.72	20.05
		6	0	19.11	18.84	18.75

LTE Band / BW	Modulation	RB Size	RB Offset	Low CH	Mid CH	High CH
				26705CH	26740CH	26775CH
				815.5MHz	819MHz	822.5MHz
26 / 3M	QPSK	1	0	21.41	21.36	21.44
		1	7	21.50	21.50	21.57
		1	14	21.38	21.36	21.45
		8	0	20.65	20.61	20.60
		8	4	20.70	20.66	20.64
		8	7	20.63	20.58	20.58
		15	0	20.59	20.60	20.57
	16QAM	1	0	20.84	20.49	20.31
		1	7	20.95	20.60	20.46
		1	14	20.80	20.45	20.28
		8	0	19.75	19.65	19.72
		8	4	19.82	19.74	19.78
		8	7	19.76	19.68	19.70
		15	0	19.64	19.59	19.65
	64QAM	1	0	19.66	19.74	19.85
		1	7	19.82	19.85	19.96
		1	14	19.67	19.71	19.83
		8	0	18.76	18.68	18.79
		8	4	18.82	18.72	18.82
		8	7	18.76	18.64	18.73
		15	0	18.75	18.69	18.67

LTE Band / BW	Modulation	RB Size	RB Offset	Low CH	Mid CH	High CH
				26715CH	26740CH	26765CH
				816.5MHz	819MHz	821.5MHz
26 / 5M	QPSK	1	0	21.71	21.74	21.63
		1	13	21.85	21.86	21.75
		1	24	21.68	21.70	21.65
		12	0	20.64	20.62	20.60
		12	6	20.73	20.70	20.68
		12	11	20.75	20.71	20.70
		25	0	20.71	20.71	20.68
	16QAM	1	0	21.19	20.77	20.81
		1	13	21.31	20.89	20.94
		1	24	21.15	20.78	20.81
		12	0	19.79	19.70	19.73
		12	6	19.91	19.78	19.81
		12	11	19.92	19.80	19.84
		25	0	19.80	19.68	19.72
	64QAM	1	0	20.00	19.91	19.62
		1	13	20.14	20.06	19.72
		1	24	19.99	19.96	19.63
		12	0	18.68	18.79	18.73
		12	6	18.79	18.89	18.85
		12	11	18.80	18.89	18.86
		25	0	18.77	18.84	18.73

LTE Band / BW	Modulation	RB Size	RB Offset	Mid CH
				26740CH
				819MHz
26 / 10M	QPSK	1	0	21.79
		1	25	21.79
		1	49	21.74
		25	0	20.60
		25	13	20.76
		25	25	20.77
		50	0	20.64
	16QAM	1	0	21.12
		1	25	21.16
		1	49	21.08
		25	0	19.63
		25	13	19.82
		25	25	19.80
		50	0	19.77
	64QAM	1	0	19.92
		1	25	19.92
		1	49	19.86
		25	0	18.77
		25	13	18.94
		25	25	18.93
		50	0	18.86

Output Power For Second Antenna (dBm):

LTE Band / BW	Modulation	RB Size	RB Offset	Low CH	Mid CH	High CH
				26697CH	26740CH	26783CH
				814.7MHz	819MHz	823.3MHz
26 / 1.4M	QPSK	1	0	22.99	22.94	22.81
		1	2	23.01	22.98	22.90
		1	5	22.90	22.93	22.86
		3	0	23.02	23.02	22.98
		3	1	23.04	23.03	23.01
		3	2	23.02	23.01	23.00
		6	0	22.09	22.08	22.07
	16QAM	1	0	22.31	21.98	22.01
		1	2	22.35	22.00	22.07
		1	5	22.27	21.97	22.02
		3	0	22.23	22.23	22.05
		3	1	22.24	22.25	22.07
		3	2	22.21	22.24	22.07
		6	0	20.99	21.28	21.23
	64QAM	1	0	21.19	21.24	21.42
		1	2	21.28	21.28	21.53
		1	5	21.15	21.30	21.42
		3	0	21.29	21.07	21.46
		3	1	21.32	21.10	21.47
		3	2	21.29	21.10	21.45
		6	0	20.44	20.22	20.11

LTE Band / BW	Modulation	RB Size	RB Offset	Low CH	Mid CH	High CH
				26705CH	26740CH	26775CH
				815.5MHz	819MHz	822.5MHz
26 / 3M	QPSK	1	0	22.84	22.74	22.73
		1	7	22.97	22.86	22.87
		1	14	22.81	22.72	22.74
		8	0	22.00	21.97	21.97
		8	4	22.06	22.04	22.02
		8	7	21.99	21.99	21.96
		15	0	21.98	21.94	21.98
	16QAM	1	0	22.17	21.91	21.73
		1	7	22.32	21.99	21.85
		1	14	22.18	21.86	21.65
		8	0	21.11	21.02	21.12
		8	4	21.19	21.11	21.16
		8	7	21.12	21.04	21.08
		15	0	20.99	20.94	21.03
	64QAM	1	0	21.04	21.15	21.27
		1	7	21.20	21.26	21.39
		1	14	21.04	21.14	21.21
		8	0	20.14	20.07	20.18
		8	4	20.22	20.09	20.21
		8	7	20.15	20.04	20.11
		15	0	20.11	20.09	20.07

LTE Band / BW	Modulation	RB Size	RB Offset	Low CH	Mid CH	High CH
				26715CH	26740CH	26765CH
				816.5MHz	819MHz	821.5MHz
26 / 5M	QPSK	1	0	23.06	23.07	23.10
		1	13	23.17	23.21	23.21
		1	24	23.06	23.08	23.13
		12	0	22.00	21.98	21.94
		12	6	22.09	22.11	22.07
		12	11	22.10	22.16	22.12
		25	0	22.12	22.11	22.04
	16QAM	1	0	22.56	22.18	22.23
		1	13	22.69	22.34	22.34
		1	24	22.54	22.20	22.21
		12	0	21.19	21.04	21.05
		12	6	21.26	21.19	21.19
		12	11	21.30	21.22	21.25
		25	0	21.22	21.08	21.10
	64QAM	1	0	21.40	21.32	21.01
		1	13	21.53	21.47	21.12
		1	24	21.38	21.35	21.03
		12	0	20.09	20.15	20.08
		12	6	20.19	20.28	20.23
		12	11	20.21	20.32	20.28
		25	0	20.18	20.22	20.10

LTE Band / BW	Modulation	RB Size	RB Offset	Mid CH
				26740CH
				819MHz
26 / 10M	QPSK	1	0	23.18
		1	25	23.20
		1	49	23.13
		25	0	21.96
		25	13	22.18
		25	25	22.25
		50	0	22.09
	16QAM	1	0	22.47
		1	25	22.56
		1	49	22.46
		25	0	21.01
		25	13	21.21
		25	25	21.30
		50	0	21.18
	64QAM	1	0	21.27
		1	25	21.32
		1	49	21.28
		25	0	20.14
		25	13	20.31
		25	25	20.44
		50	0	20.31

ERP For Second Antenna (dBm):

LTE Band / BW	Modulation	RB Size	RB Offset	Low CH	Mid CH	High CH
				26697CH	26740CH	26783CH
				814.7MHz	819MHz	823.3MHz
26 / 1.4M	QPSK	1	0	21.34	21.29	21.16
		1	2	21.36	21.33	21.25
		1	5	21.25	21.28	21.21
		3	0	21.37	21.37	21.33
		3	1	21.39	21.38	21.36
		3	2	21.37	21.36	21.35
		6	0	20.44	20.43	20.42
	16QAM	1	0	20.66	20.33	20.36
		1	2	20.70	20.35	20.42
		1	5	20.62	20.32	20.37
		3	0	20.58	20.58	20.40
		3	1	20.59	20.60	20.42
		3	2	20.56	20.59	20.42
	64QAM	6	0	19.34	19.63	19.58
		1	0	19.54	19.59	19.77
		1	2	19.63	19.63	19.88
		1	5	19.50	19.65	19.77
		3	0	19.64	19.42	19.81
		3	1	19.67	19.45	19.82
		3	2	19.64	19.45	19.80
	6	0	18.79	18.57	18.46	

LTE Band / BW	Modulation	RB Size	RB Offset	Low CH	Mid CH	High CH
				26705CH	26740CH	26775CH
				815.5MHz	819MHz	822.5MHz
26 / 3M	QPSK	1	0	21.19	21.09	21.08
		1	7	21.32	21.21	21.22
		1	14	21.16	21.07	21.09
		8	0	20.35	20.32	20.32
		8	4	20.41	20.39	20.37
		8	7	20.34	20.34	20.31
		15	0	20.33	20.29	20.33
	16QAM	1	0	20.52	20.26	20.08
		1	7	20.67	20.34	20.20
		1	14	20.53	20.21	20.00
		8	0	19.46	19.37	19.47
		8	4	19.54	19.46	19.51
		8	7	19.47	19.39	19.43
		15	0	19.34	19.29	19.38
	64QAM	1	0	19.39	19.50	19.62
		1	7	19.55	19.61	19.74
		1	14	19.39	19.49	19.56
		8	0	18.49	18.42	18.53
		8	4	18.57	18.44	18.56
		8	7	18.50	18.39	18.46
		15	0	18.46	18.44	18.42

LTE Band / BW	Modulation	RB Size	RB Offset	Low CH	Mid CH	High CH
				26715CH	26740CH	26765CH
				816.5MHz	819MHz	821.5MHz
26 / 5M	QPSK	1	0	21.41	21.42	21.45
		1	13	21.52	21.56	21.56
		1	24	21.41	21.43	21.48
		12	0	20.35	20.33	20.29
		12	6	20.44	20.46	20.42
		12	11	20.45	20.51	20.47
		25	0	20.47	20.46	20.39
	16QAM	1	0	20.91	20.53	20.58
		1	13	21.04	20.69	20.69
		1	24	20.89	20.55	20.56
		12	0	19.54	19.39	19.40
		12	6	19.61	19.54	19.54
		12	11	19.65	19.57	19.60
		25	0	19.57	19.43	19.45
	64QAM	1	0	19.75	19.67	19.36
		1	13	19.88	19.82	19.47
		1	24	19.73	19.70	19.38
		12	0	18.44	18.50	18.43
		12	6	18.54	18.63	18.58
		12	11	18.56	18.67	18.63
		25	0	18.53	18.57	18.45

LTE Band / BW	Modulation	RB Size	RB Offset	Mid CH
				26740CH
				819MHz
26 / 10M	QPSK	1	0	21.53
		1	25	21.55
		1	49	21.48
		25	0	20.31
		25	13	20.53
		25	25	20.60
		50	0	20.44
	16QAM	1	0	20.82
		1	25	20.91
		1	49	20.81
		25	0	19.36
		25	13	19.56
		25	25	19.65
		50	0	19.53
	64QAM	1	0	19.62
		1	25	19.67
		1	49	19.63
		25	0	18.49
		25	13	18.66
		25	25	18.79
		50	0	18.66

APPENDIX B - OCCUPIED BANDWIDTH

LTE Band 26_1.4M					
QPSK					
Channel	Frequency (MHz)	99% Occupied Bandwidth (MHz)	Channel	Frequency (MHz)	26dB Bandwidth (MHz)
26697	814.7	1.1026	26697	814.7	1.295
26740	819	1.0846	26740	819	1.269
26783	823.3	1.0953	26783	823.3	1.260
16QAM					
Channel	Frequency (MHz)	99% Occupied Bandwidth (MHz)	Channel	Frequency (MHz)	26dB Bandwidth (MHz)
26697	814.7	1.0895	26697	814.7	1.276
26740	819	1.0907	26740	819	1.280
26783	823.3	1.0950	26783	823.3	1.275
64QAM					
Channel	Frequency (MHz)	99% Occupied Bandwidth (MHz)	Channel	Frequency (MHz)	26dB Bandwidth (MHz)
26697	814.7	1.0840	26697	814.7	1.256
26740	819	1.0898	26740	819	1.285
26783	823.3	1.0888	26783	823.3	1.259

Spectrum Plot

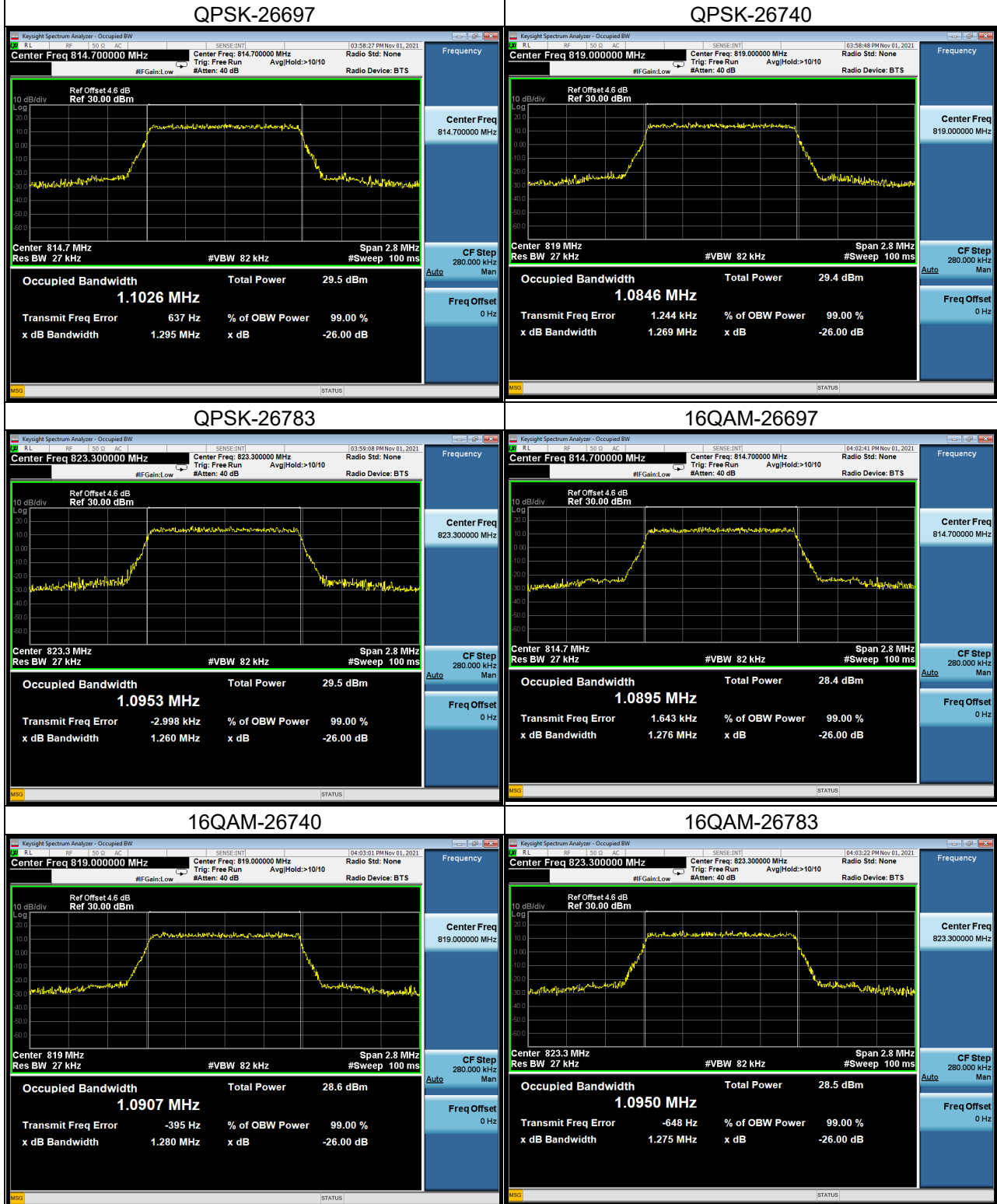

Spectrum Plot

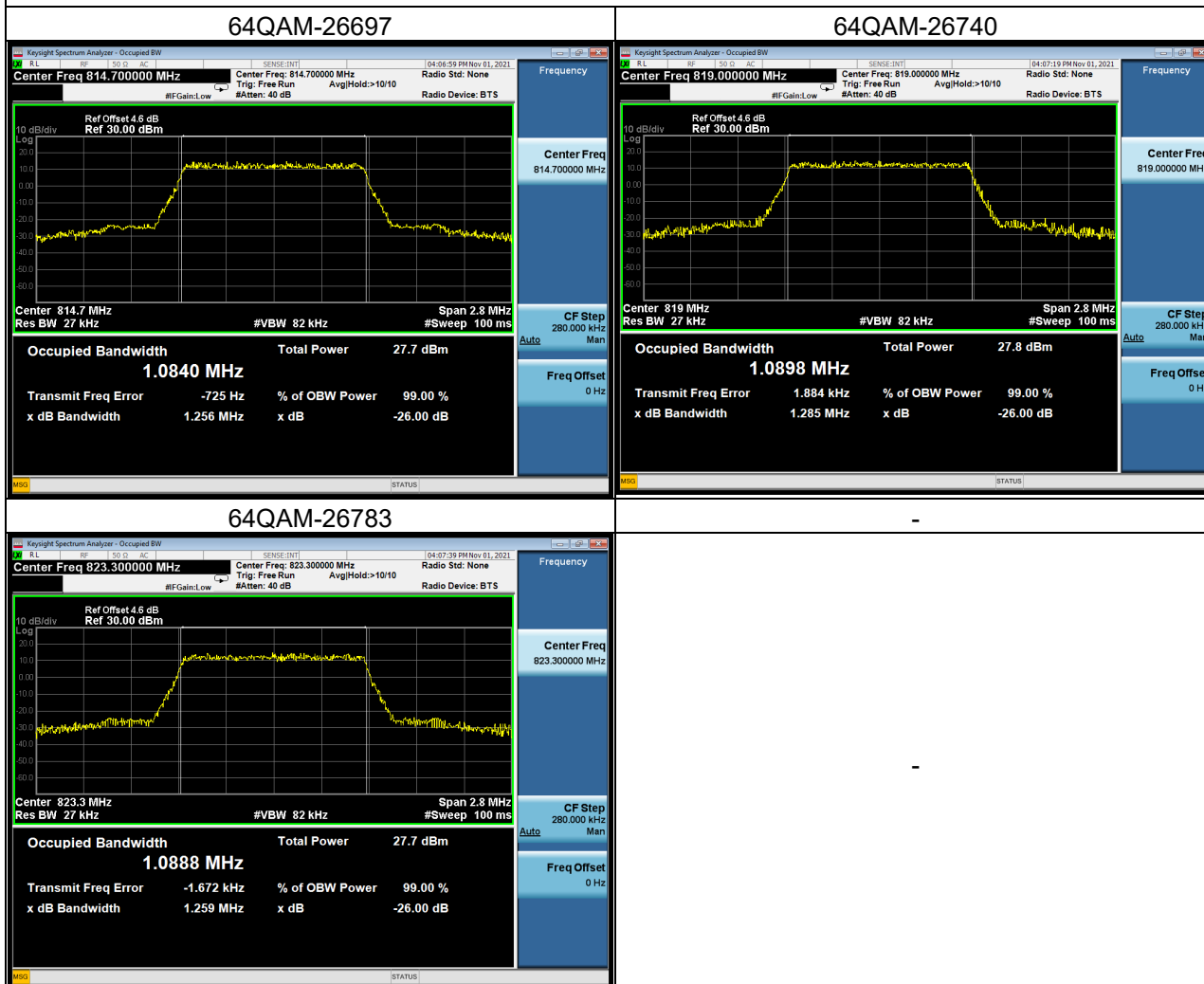

LTE Band 26_3M					
QPSK					
Channel	Frequency (MHz)	99% Occupied Bandwidth (MHz)	Channel	Frequency (MHz)	26dB Bandwidth (MHz)
26705	815.5	2.6899	26705	815.5	2.980
26740	819	2.6864	26740	819	2.965
26775	822.5	2.6824	26775	822.5	3.001
16QAM					
Channel	Frequency (MHz)	99% Occupied Bandwidth (MHz)	Channel	Frequency (MHz)	26dB Bandwidth (MHz)
26705	815.5	2.6865	26705	815.5	2.981
26740	819	2.6812	26740	819	2.978
26775	822.5	2.6871	26775	822.5	2.970
64QAM					
Channel	Frequency (MHz)	99% Occupied Bandwidth (MHz)	Channel	Frequency (MHz)	26dB Bandwidth (MHz)
26705	815.5	2.6900	26705	815.5	2.944
26740	819	2.6903	26740	819	2.947
26775	822.5	2.6951	26775	822.5	2.977

Spectrum Plot

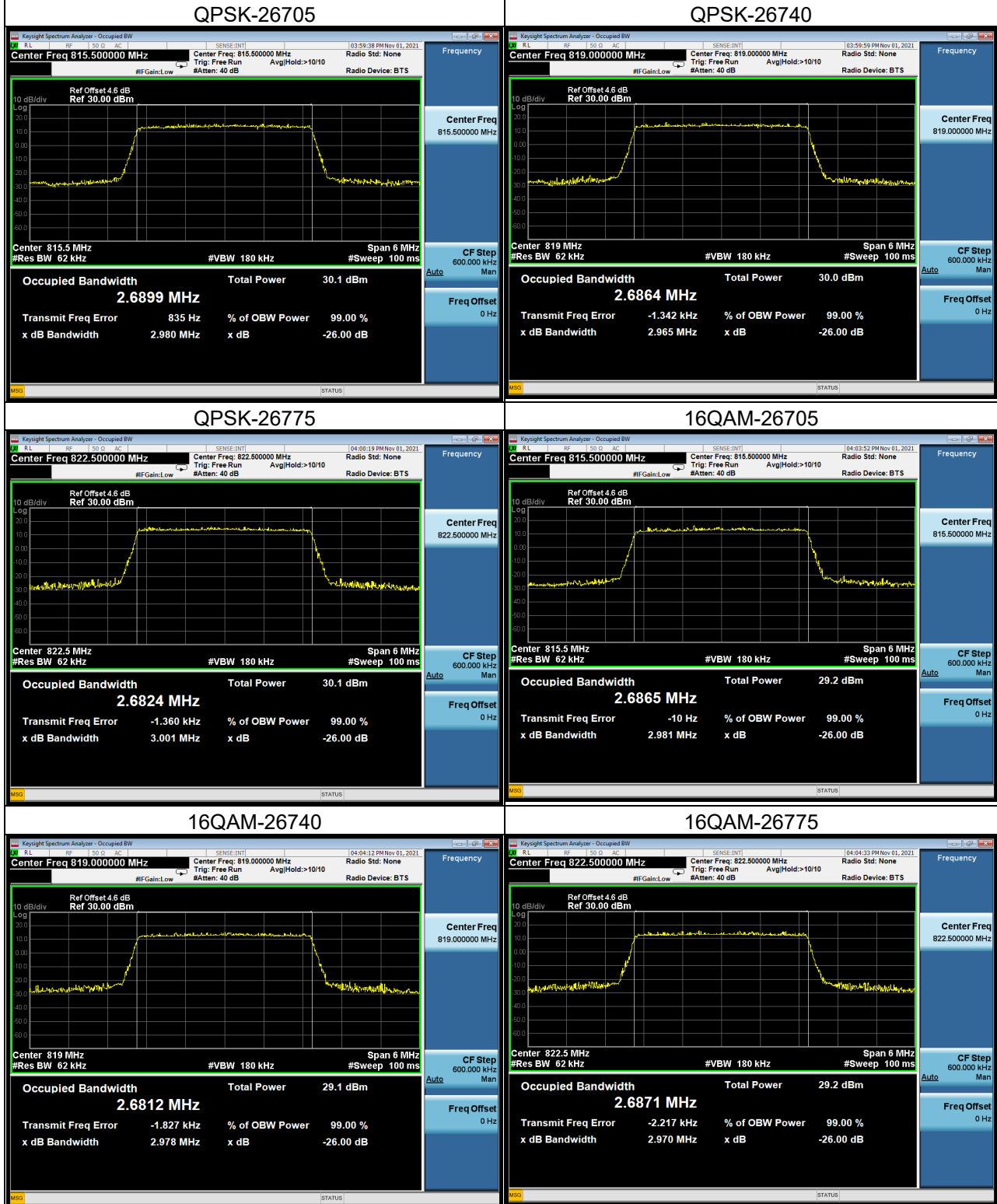

Spectrum Plot

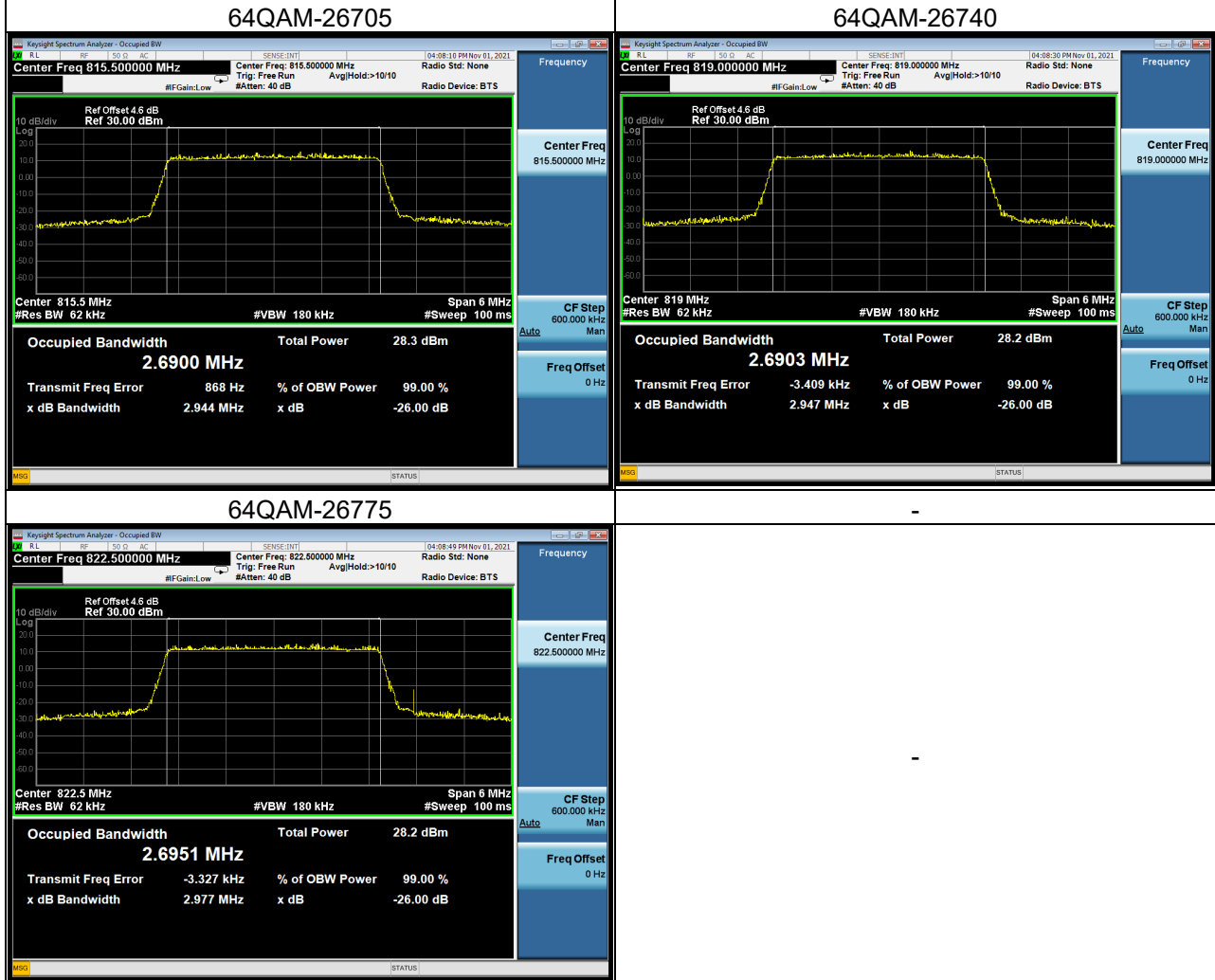

LTE Band 26_5M					
QPSK					
Channel	Frequency (MHz)	99% Occupied Bandwidth (MHz)	Channel	Frequency (MHz)	26dB Bandwidth (MHz)
26715	816.5	4.4936	26715	816.5	4.884
26740	819	4.4980	26740	819	4.898
26765	821.5	4.4990	26765	821.5	4.900
16QAM					
Channel	Frequency (MHz)	99% Occupied Bandwidth (MHz)	Channel	Frequency (MHz)	26dB Bandwidth (MHz)
26715	816.5	4.4912	26715	816.5	4.876
26740	819	4.4924	26740	819	4.851
26765	821.5	4.5010	26765	821.5	4.895
64QAM					
Channel	Frequency (MHz)	99% Occupied Bandwidth (MHz)	Channel	Frequency (MHz)	26dB Bandwidth (MHz)
26715	816.5	4.5002	26715	816.5	4.875
26740	819	4.5060	26740	819	4.897
26765	821.5	4.4971	26765	821.5	4.892

Spectrum Plot

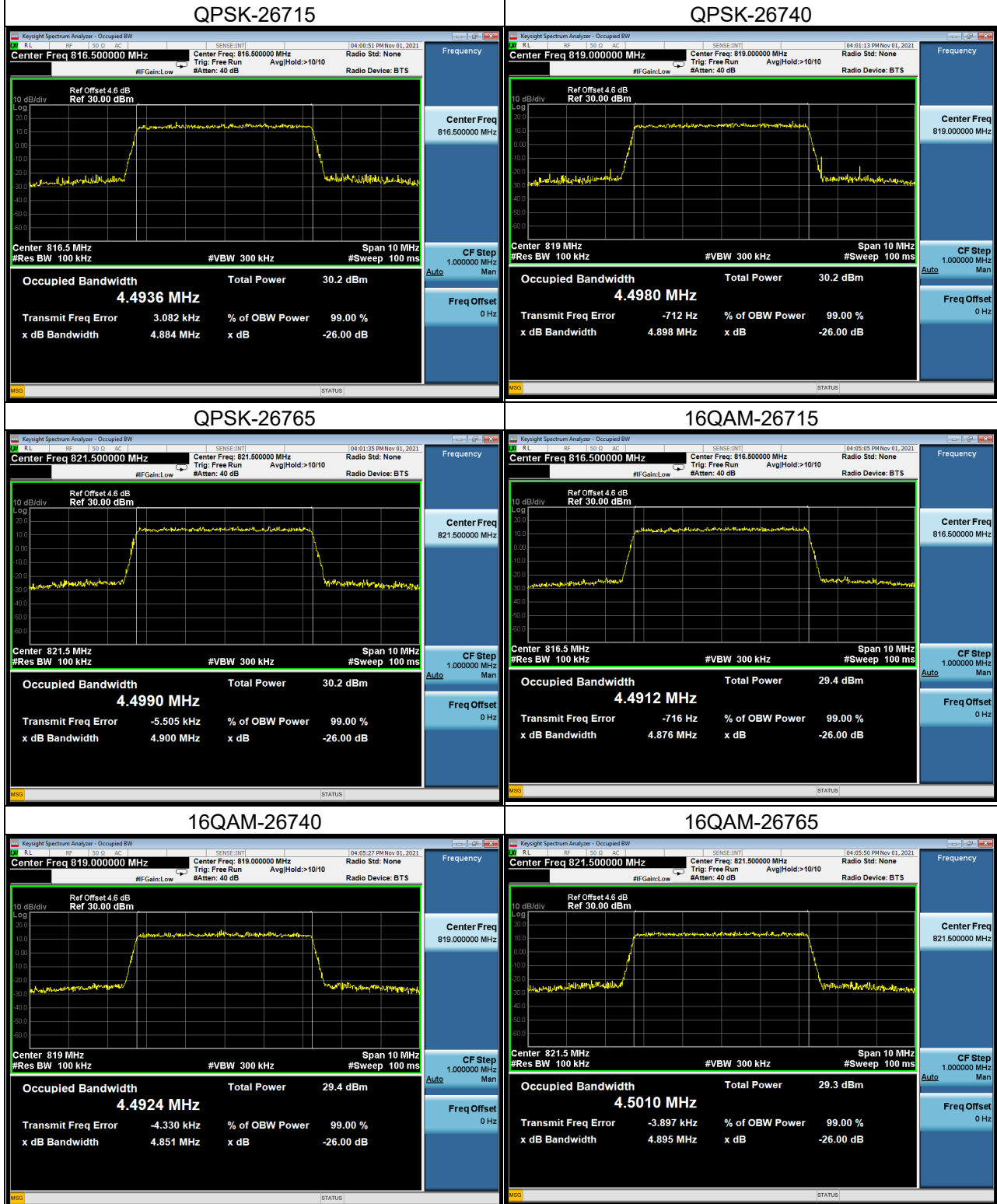

Spectrum Plot

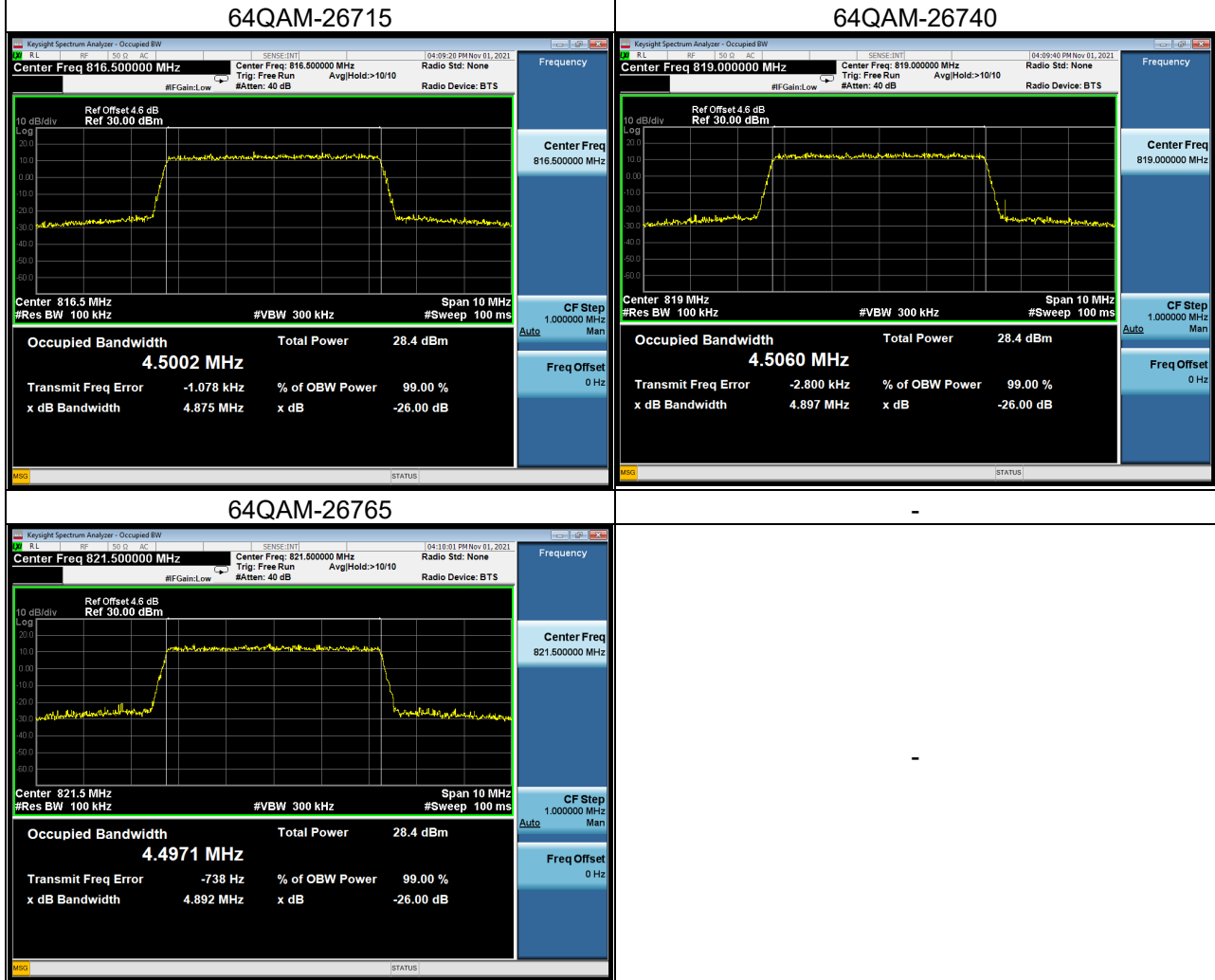

LTE Band 26_10M					
QPSK					
Channel	Frequency (MHz)	99% Occupied Bandwidth (MHz)	Channel	Frequency (MHz)	26dB Bandwidth (MHz)
26740	819	8.9533	26740	819	9.713
16QAM					
Channel	Frequency (MHz)	99% Occupied Bandwidth (MHz)	Channel	Frequency (MHz)	26dB Bandwidth (MHz)
26740	819	8.9354	26740	819	9.675
64QAM					
Channel	Frequency (MHz)	99% Occupied Bandwidth (MHz)	Channel	Frequency (MHz)	26dB Bandwidth (MHz)
26740	819	8.9513	26740	819	9.738

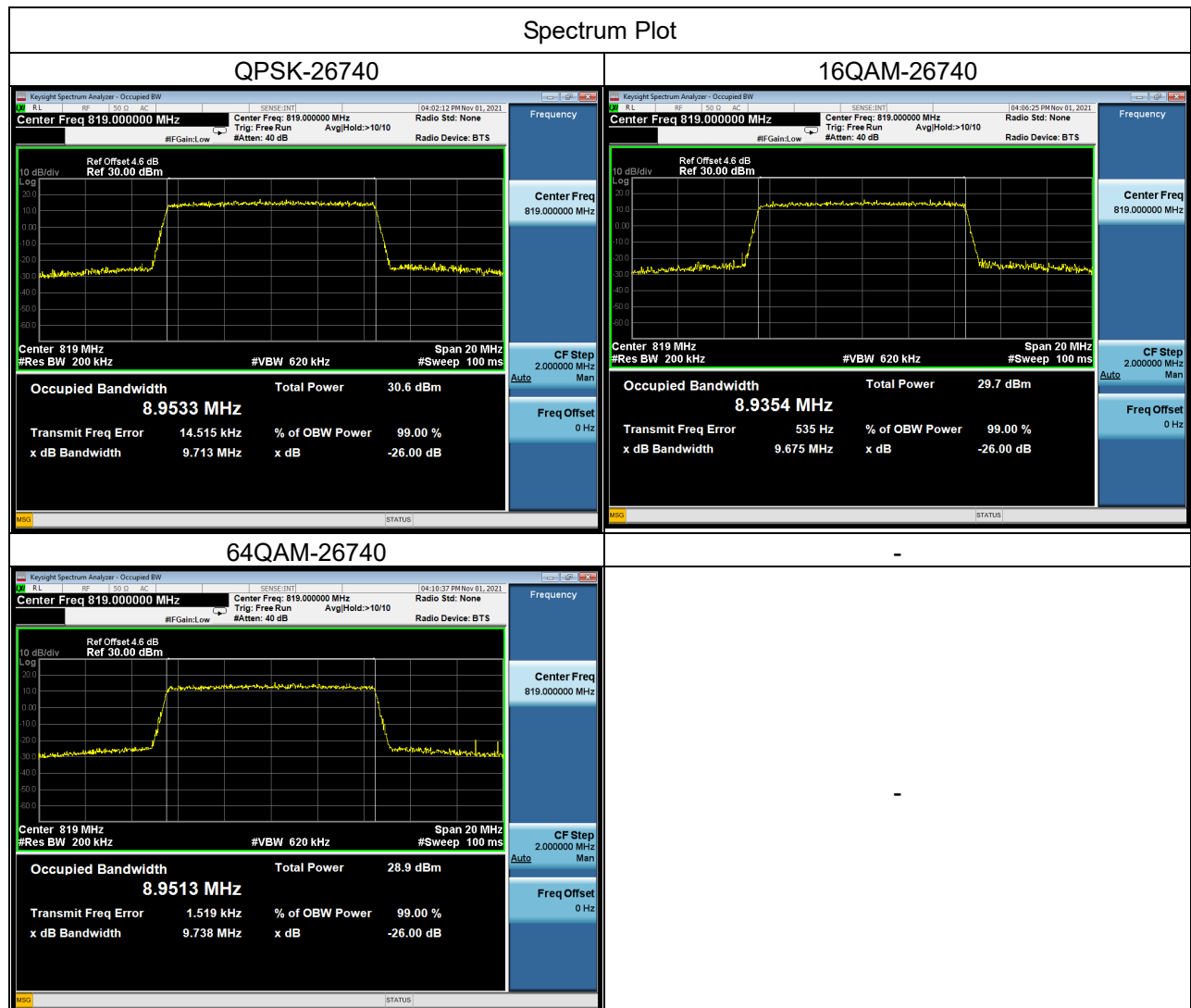

APPENDIX C - CONDUCTED SPURIOUS EMISSIONS

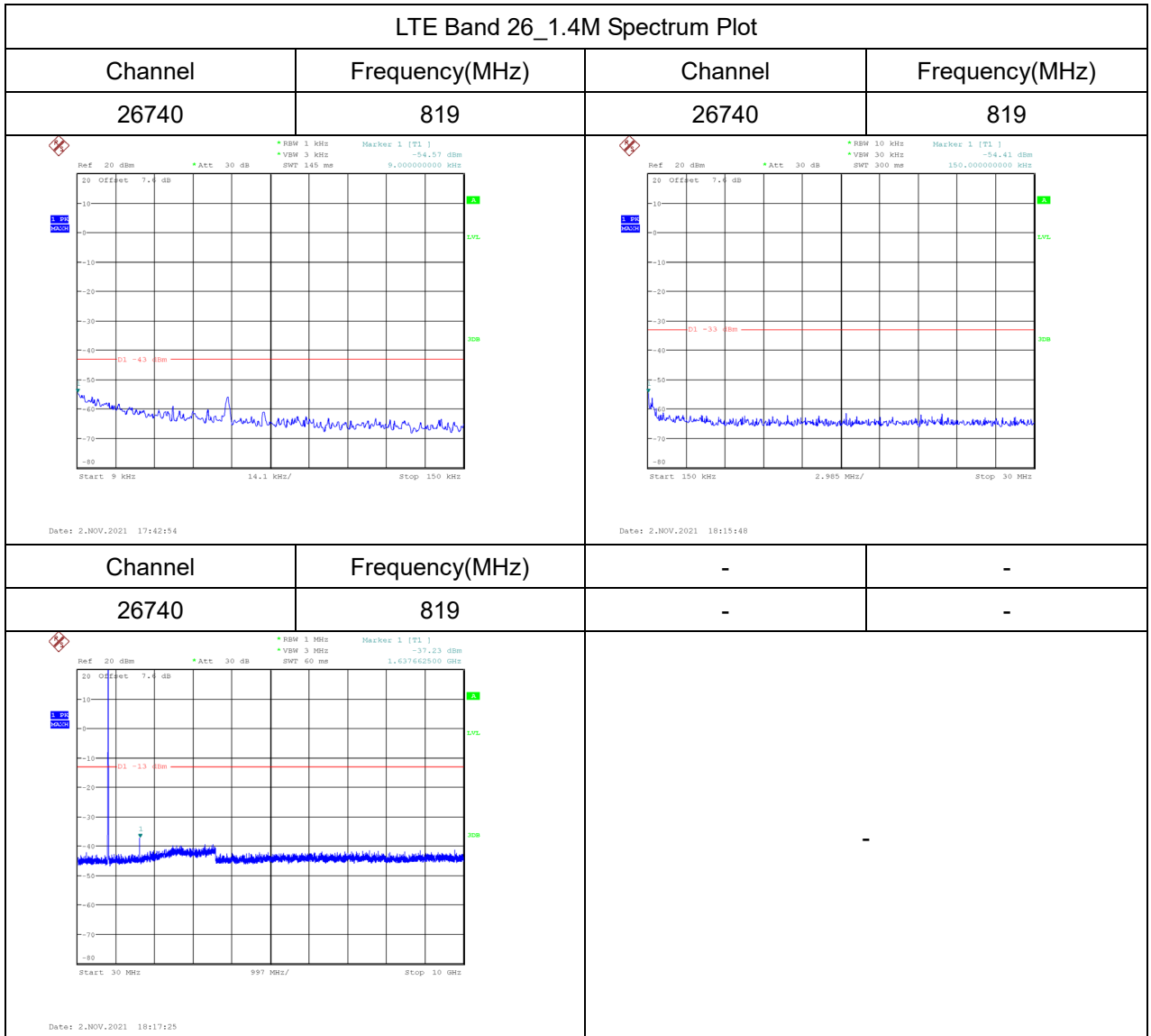

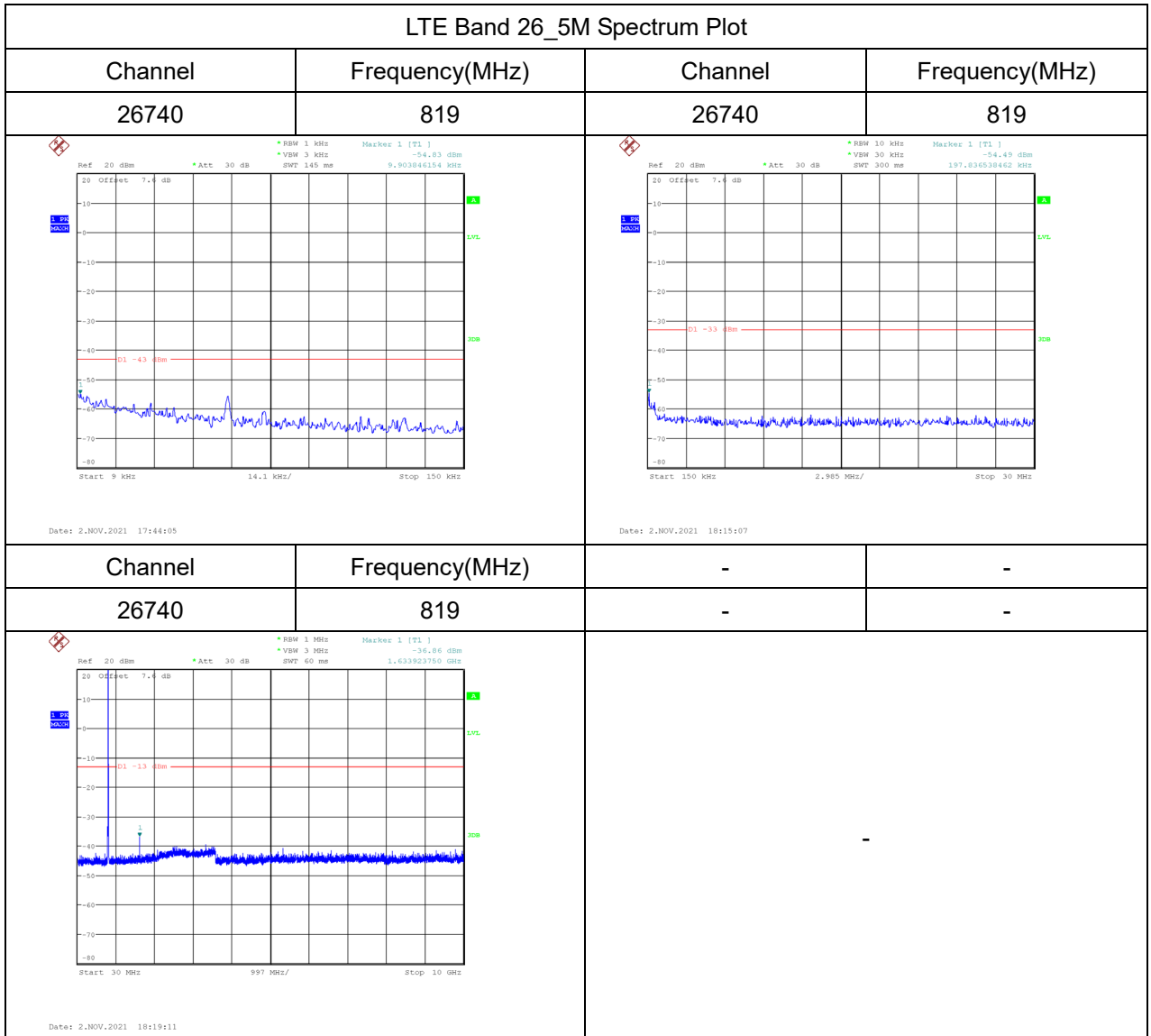

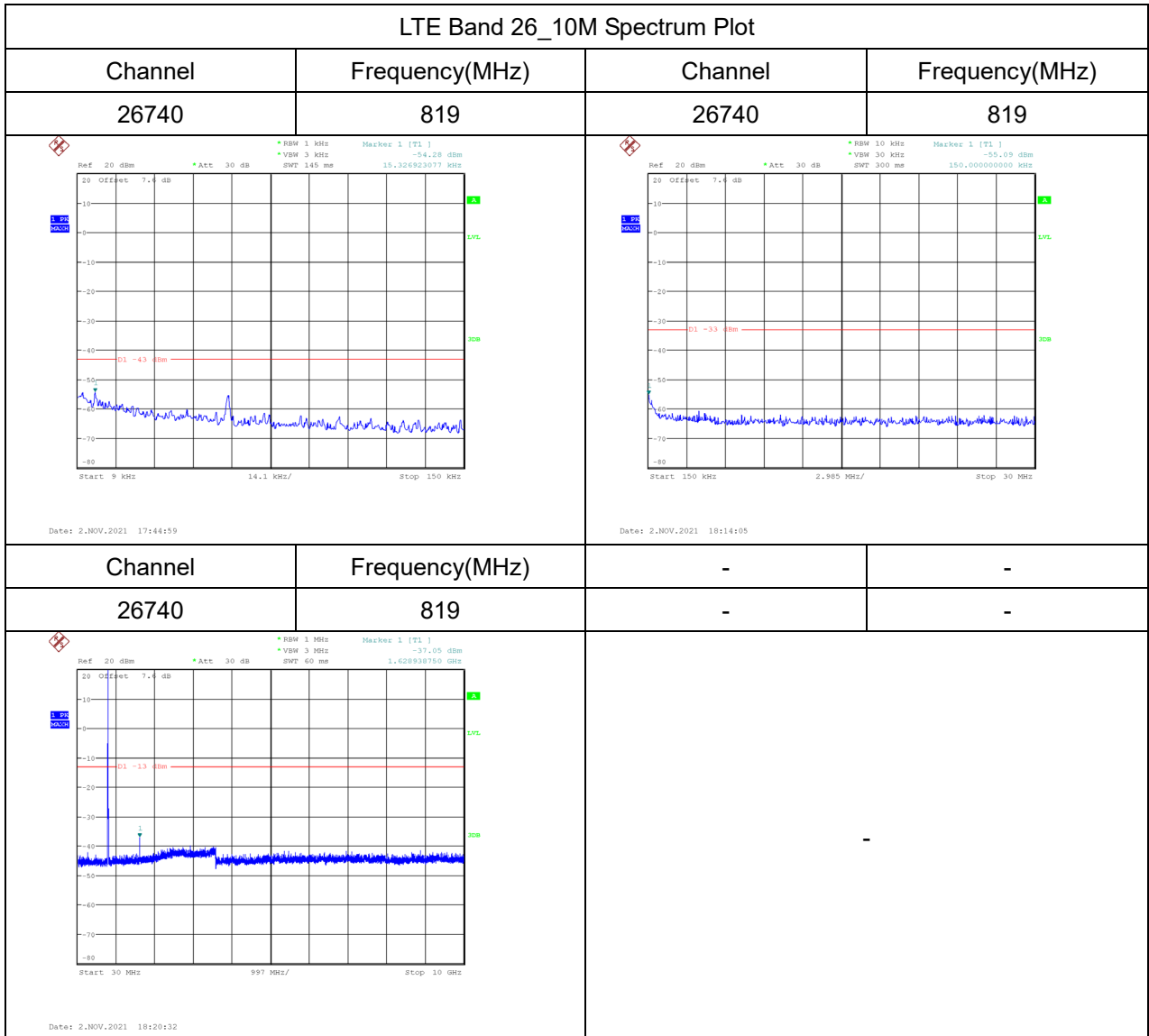

APPENDIX D - RADIATED SPURIOUS EMISSIONS (9KHZ TO 30MHZ)

Test Mode	TX Mode
-----------	---------

Ant 0°

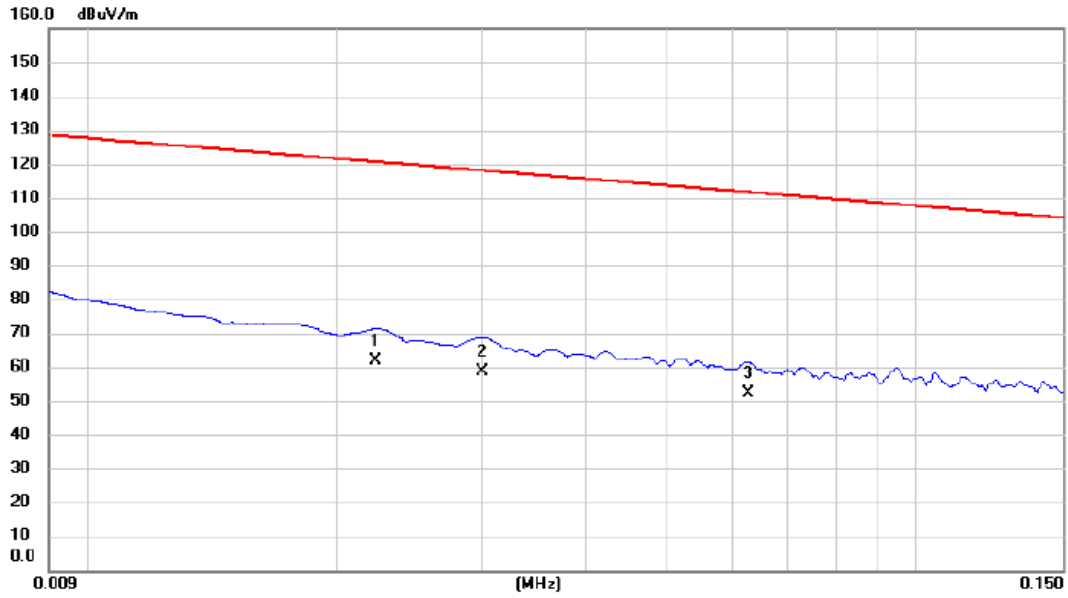

No.	Mk.	Freq.	Reading Level	Correct Factor	Measurement	Limit	Margin	Detector	Comment
		MHz	dBuV	dB	dBuV/m	dBuV/m	dB		
1	*	0.0223	47.56	14.24	61.80	120.64	-58.84	AVG	
2		0.0300	44.69	14.06	58.75	118.06	-59.31	AVG	
3		0.0627	38.52	13.61	52.13	111.66	-59.53	AVG	

Test Mode	TX Mode
-----------	---------

Ant 0°

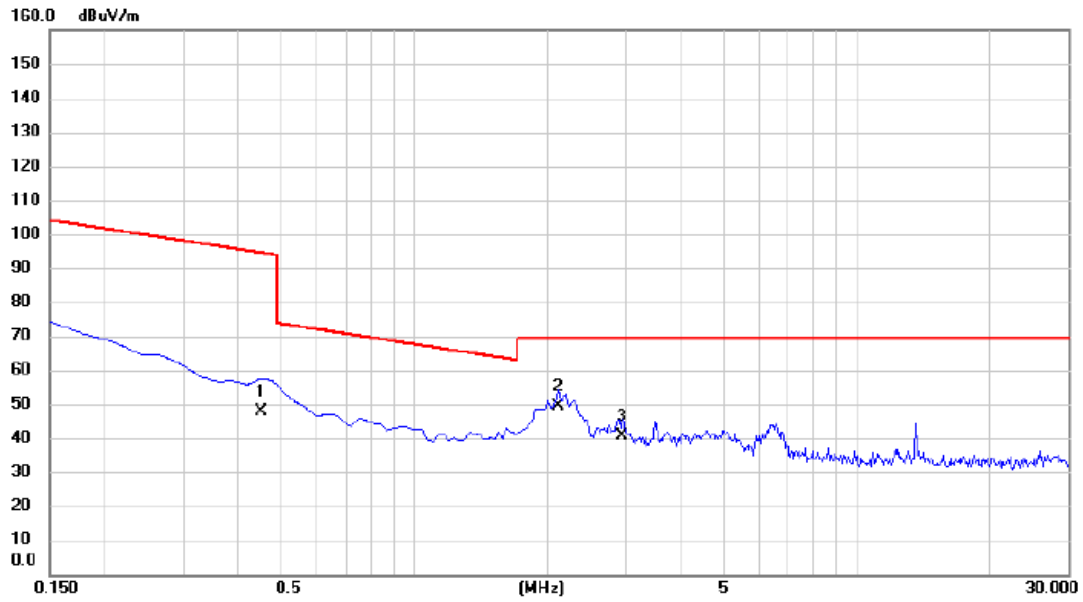

No.	Mk.	Freq. MHz	Reading Level dBuV	Correct Factor dB	Measure- ment dBuV/m	Limit dBuV/m	Margin dB	Detector	Comment
1		0.4485	34.58	13.40	47.98	94.57	-46.59	AVG	
2	*	2.1201	37.42	12.04	49.46	69.54	-20.08	QP	
3		2.9558	28.95	11.73	40.68	69.54	-28.86	QP	

Test Mode	TX Mode
-----------	---------

Ant 90°

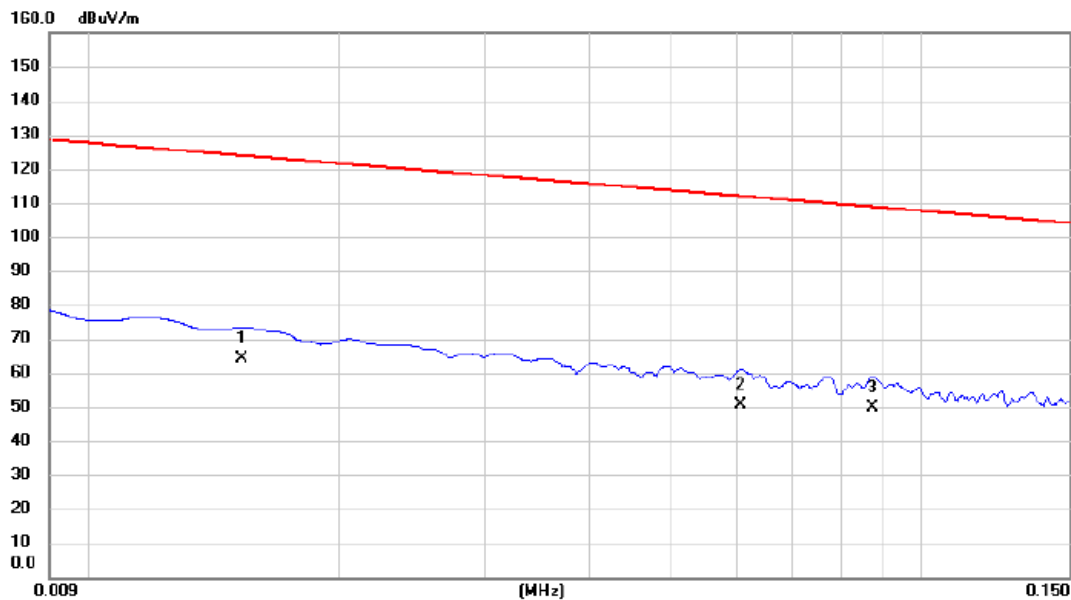

No.	Mk.	Freq.	Reading Level	Correct Factor	Measurement	Limit	Margin	Detector	Comment
		MHz	dBuV	dB	dBuV/m	dBuV/m	dB		
1		0.0153	48.32	15.77	64.09	123.91	-59.82	AVG	
2		0.0607	36.97	13.61	50.58	111.94	-61.36	AVG	
3	*	0.0871	36.25	13.64	49.89	108.80	-58.91	AVG	

Test Mode	TX Mode
-----------	---------

Ant 90°

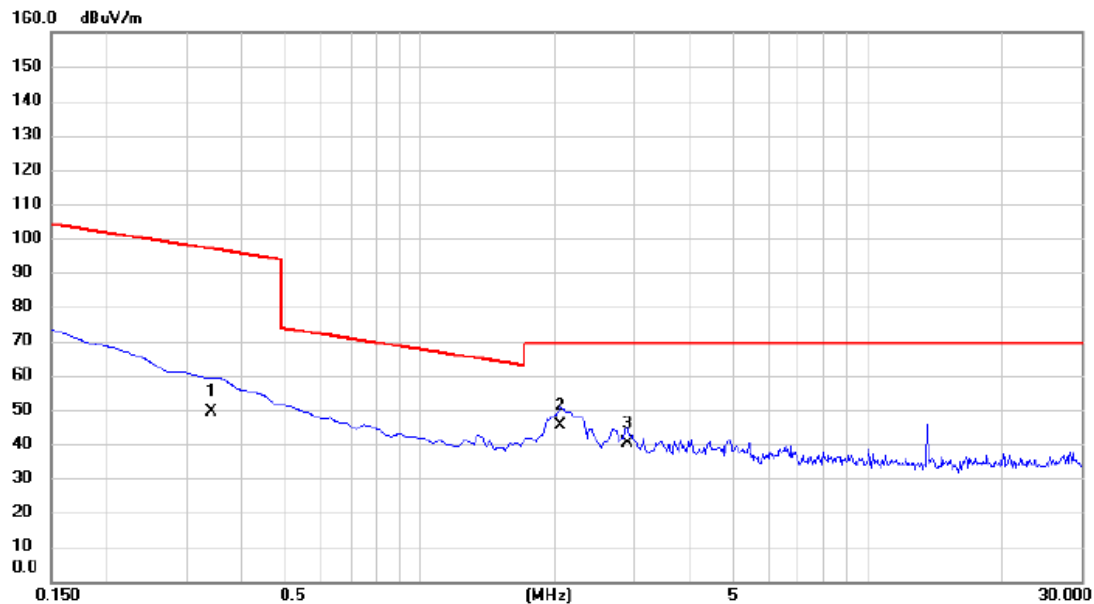

No.	Mk.	Freq. MHz	Reading Level dBuV	Correct Factor dB	Measure- ment dBuV/m	Limit dBuV/m	Margin dB	Detector	Comment
1		0.3428	35.96	13.51	49.47	96.90	-47.43	AVG	
2	*	2.0604	33.48	12.07	45.55	69.54	-23.99	QP	
3		2.8962	28.41	11.75	40.16	69.54	-29.38	QP	

APPENDIX E - RADIATED SPURIOUS EMISSIONS (30MHZ TO 1000MHZ)

Test Mode | LTE Band 26_TX CH26740_1.4M

Vertical

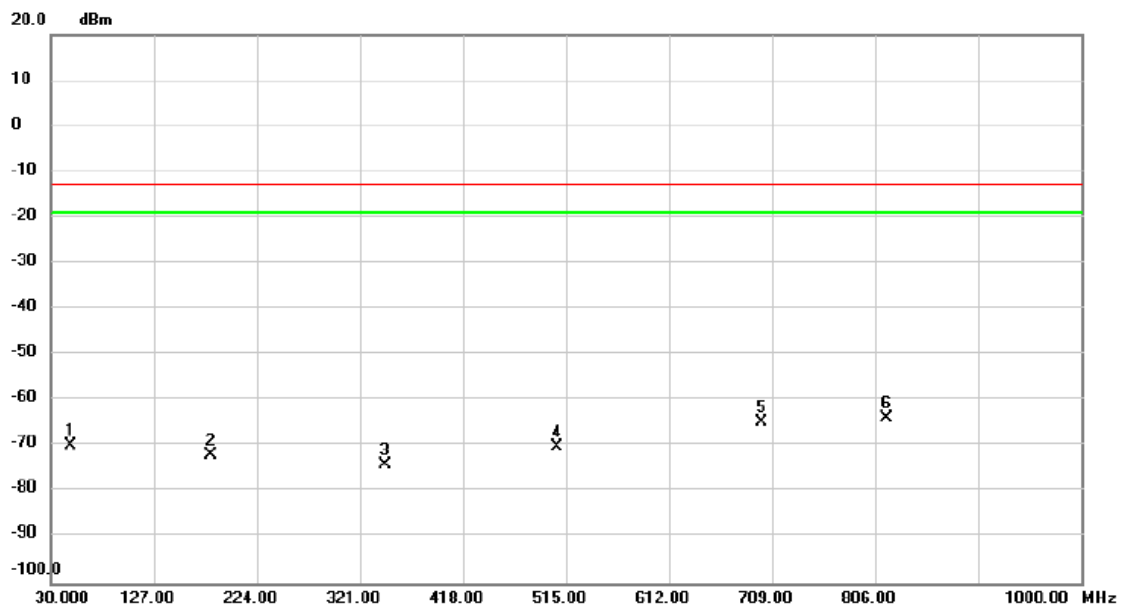

No.	Mk.	Freq. MHz	Reading Level dBm	Correct Factor dB	Measure- ment dBm	Limit dBm	Margin dB	Detector	Comment
1		48.915	-52.65	-17.15	-69.80	-13.00	-56.80	peak	
2		180.350	-56.05	-15.89	-71.94	-13.00	-58.94	peak	
3		344.280	-59.00	-14.91	-73.91	-13.00	-60.91	peak	
4		506.270	-55.06	-14.98	-70.04	-13.00	-57.04	peak	
5		699.300	-50.02	-14.69	-64.71	-13.00	-51.71	peak	
6	*	817.155	-49.51	-14.24	-63.75	-13.00	-50.75	peak	

Test Mode	LTE Band 26_TX CH26740_1.4M
-----------	-----------------------------

Horizontal

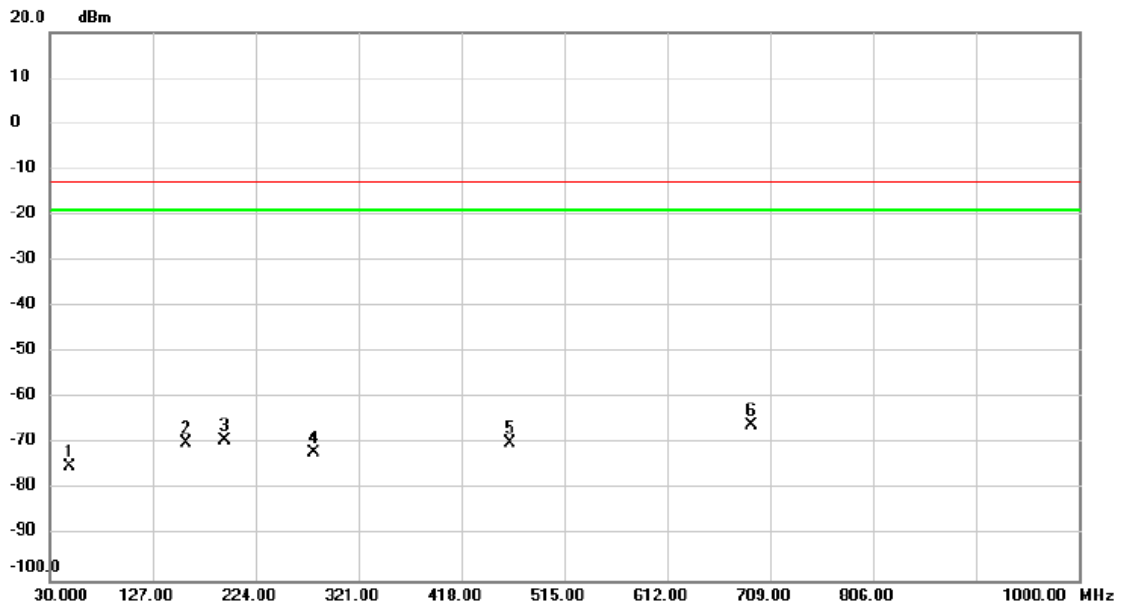

No.	Mk.	Freq.	Reading Level	Correct Factor	Measurement	Limit	Margin	Detector	Comment
		MHz	dBm	dB	dBm	dBm	dB		
1		48.915	-57.87	-17.15	-75.02	-13.00	-62.02	peak	
2		158.525	-53.78	-16.09	-69.87	-13.00	-56.87	peak	
3		194.415	-53.62	-15.76	-69.38	-13.00	-56.38	peak	
4		279.290	-56.96	-15.07	-72.03	-13.00	-59.03	peak	
5		463.590	-54.88	-14.96	-69.84	-13.00	-56.84	peak	
6	*	691.540	-51.11	-14.72	-65.83	-13.00	-52.83	peak	

Test Mode	LTE Band 26_TX CH26740_5M
-----------	---------------------------

Vertical

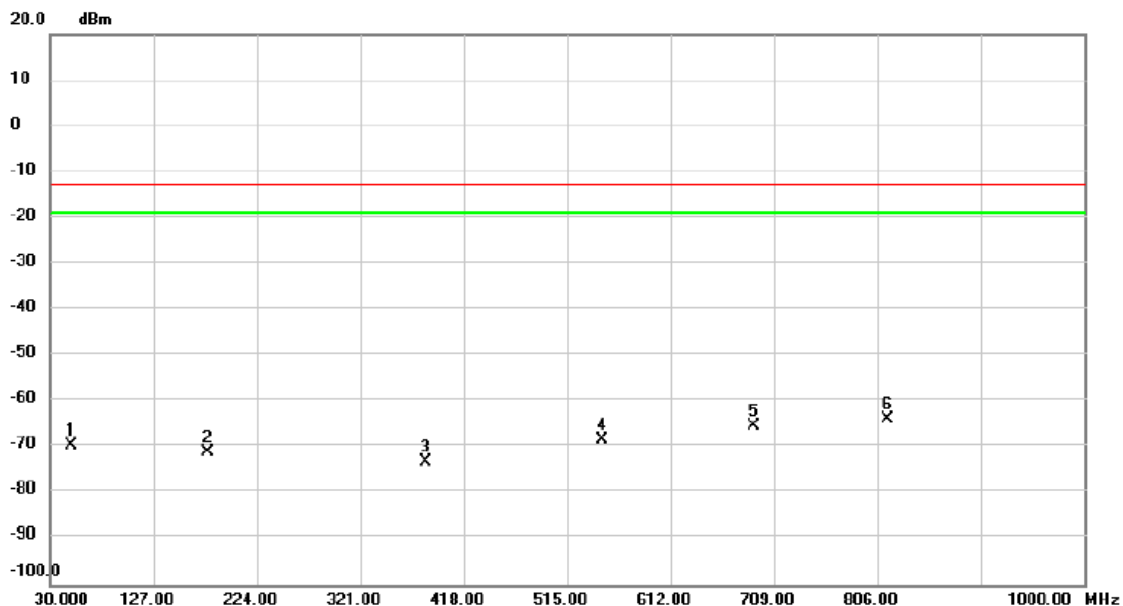

No.	Mk.	Freq. MHz	Reading Level dBm	Correct Factor dB	Measure- ment dBm	Limit dBm	Margin dB	Detector	Comment
1		49.400	-52.31	-17.14	-69.45	-13.00	-56.45	peak	
2		178.410	-55.13	-15.91	-71.04	-13.00	-58.04	peak	
3		382.595	-58.28	-14.92	-73.20	-13.00	-60.20	peak	
4		547.495	-53.42	-15.01	-68.43	-13.00	-55.43	peak	
5		690.570	-50.69	-14.72	-65.41	-13.00	-52.41	peak	
6	*	816.185	-49.59	-14.25	-63.84	-13.00	-50.84	peak	

Test Mode | LTE Band 26_TX CH26740_5M

Horizontal

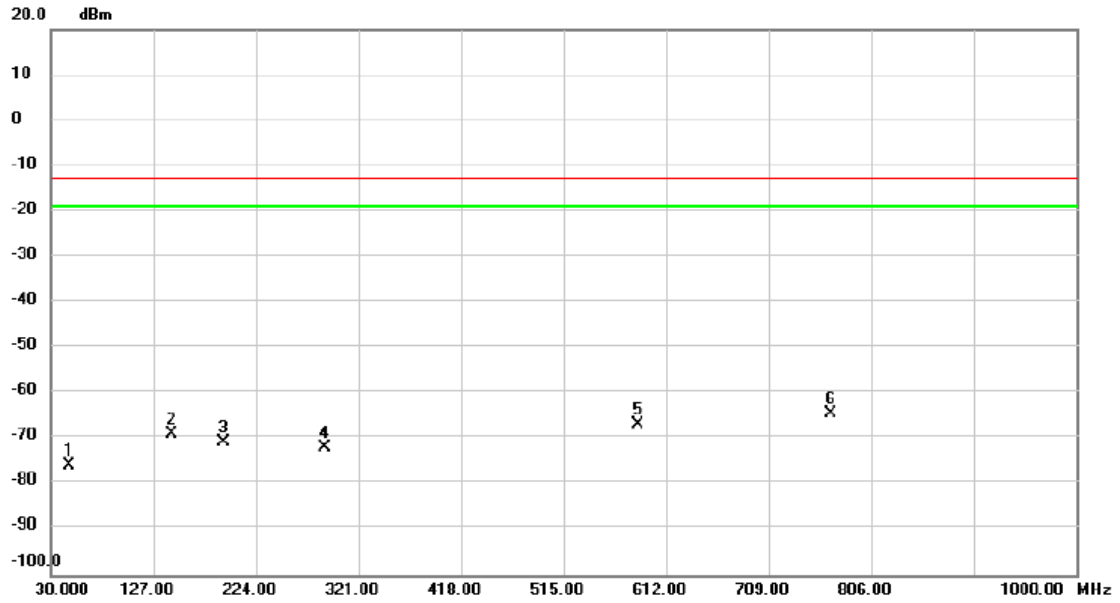

No. Mk.	Freq. MHz	Reading Level dBm	Correct Factor dB	Measurement dBm	Limit dBm	Margin dB	Detector	Comment
1	47.460	-58.79	-17.17	-75.96	-13.00	-62.96	peak	
2	144.460	-52.84	-16.22	-69.06	-13.00	-56.06	peak	
3	193.930	-54.86	-15.77	-70.63	-13.00	-57.63	peak	
4	289.960	-57.08	-14.99	-72.07	-13.00	-59.07	peak	
5	585.810	-51.76	-15.05	-66.81	-13.00	-53.81	peak	
6 *	768.170	-49.86	-14.45	-64.31	-13.00	-51.31	peak	

Test Mode LTE Band 26_TX CH26740_10M

Vertical

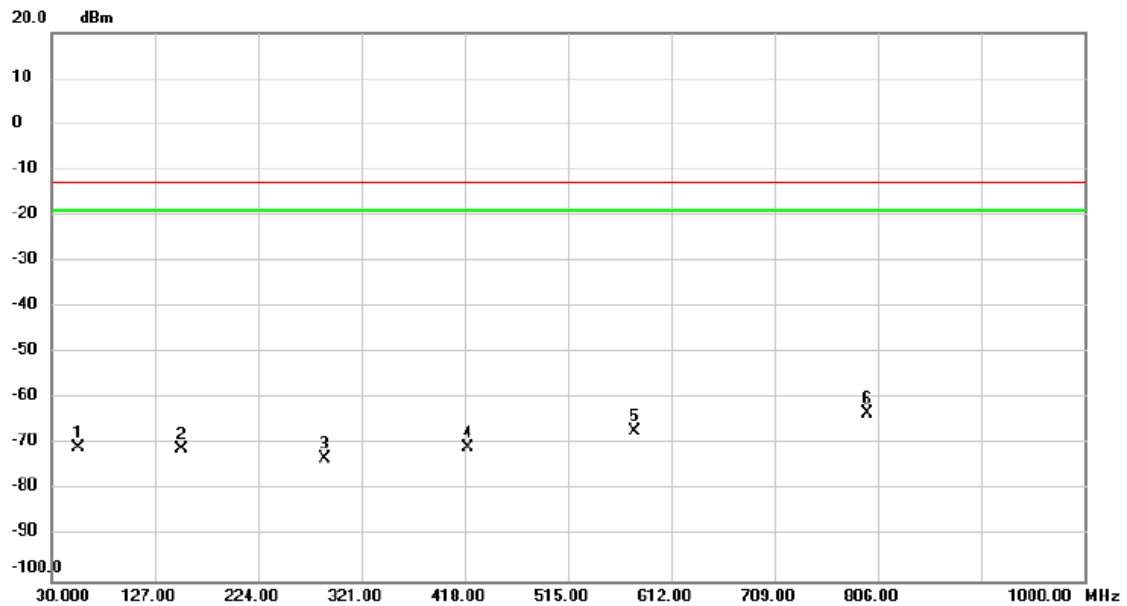

No.	Mk.	Freq. MHz	Reading Level dBm	Correct Factor dB	Measure- ment dBm	Limit dBm	Margin dB	Detector	Comment
1		55.705	-53.78	-17.07	-70.85	-13.00	-57.85	peak	
2		152.220	-55.02	-16.15	-71.17	-13.00	-58.17	peak	
3		287.050	-58.26	-15.01	-73.27	-13.00	-60.27	peak	
4		421.395	-55.89	-14.92	-70.81	-13.00	-57.81	peak	
5		577.565	-52.17	-15.04	-67.21	-13.00	-54.21	peak	
6	*	796.300	-48.92	-14.35	-63.27	-13.00	-50.27	peak	

Test Mode	LTE Band 26_TX CH26740_10M
-----------	----------------------------

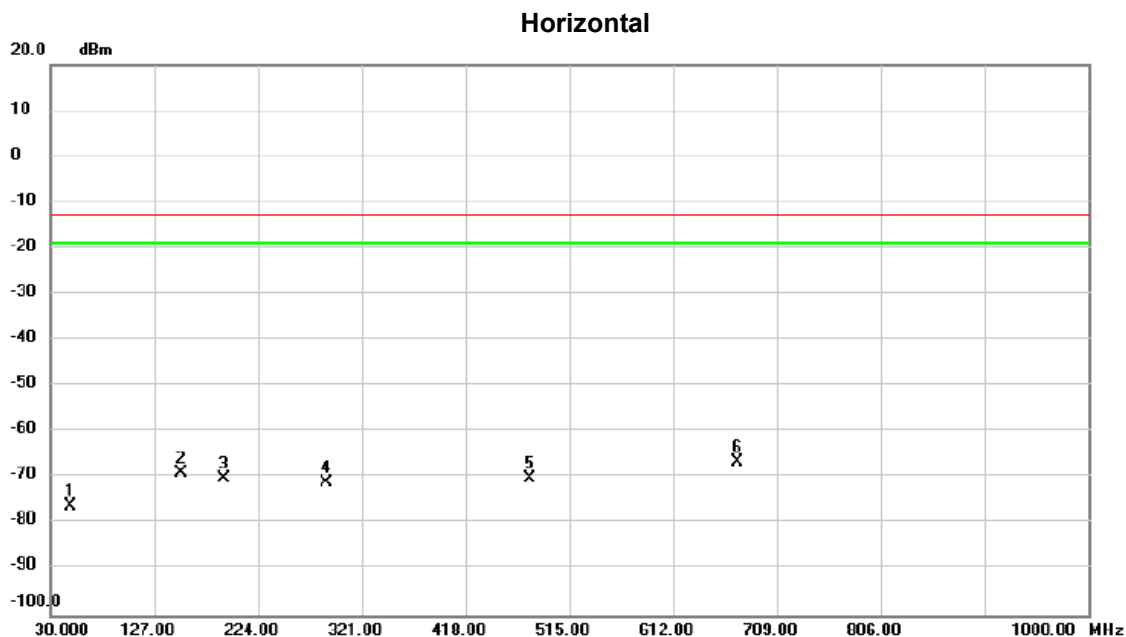

No.	Mk.	Freq. MHz	Reading Level dBm	Correct Factor dB	Measure- ment dBm	Limit dBm	Margin dB	Detector	Comment
1		48.915	-59.01	-17.15	-76.16	-13.00	-63.16	peak	
2		151.735	-52.89	-16.15	-69.04	-13.00	-56.04	peak	
3		192.475	-54.38	-15.79	-70.17	-13.00	-57.17	peak	
4		288.020	-56.12	-15.01	-71.13	-13.00	-58.13	peak	
5		478.140	-55.23	-14.96	-70.19	-13.00	-57.19	peak	
6	*	671.655	-51.69	-14.79	-66.48	-13.00	-53.48	peak	

APPENDIX F - RADIATED SPURIOUS EMISSIONS (ABOVE 1000MHZ)

Test Mode | LTE Band 26_TX CH26740_1.4M

Vertical

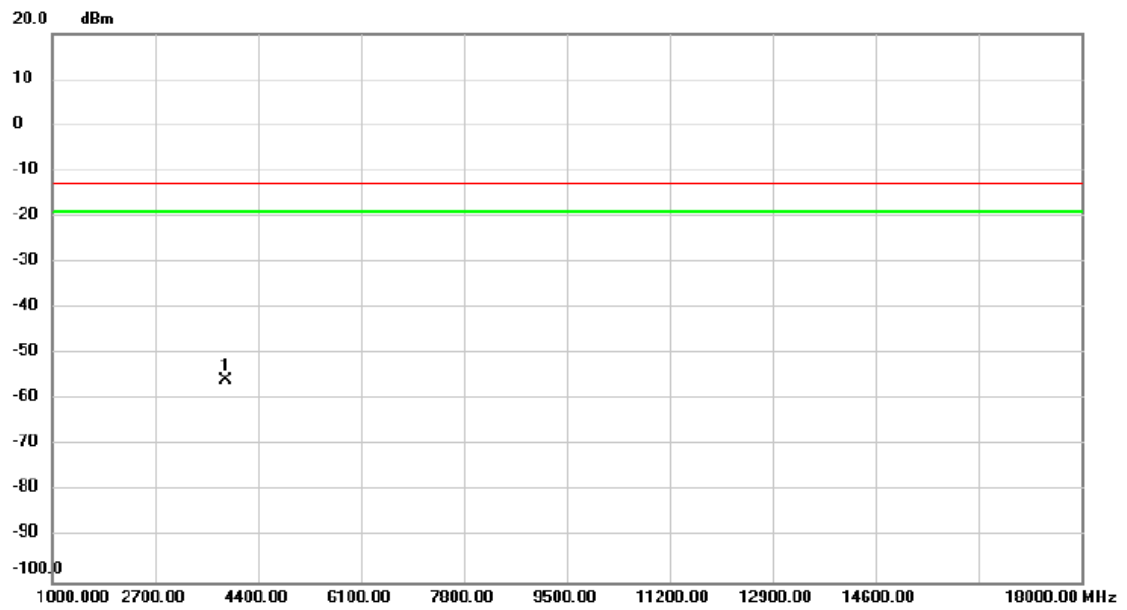

No.	Mk.	Freq. MHz	Reading Level dBm	Correct Factor dB	Measure- ment dBm	Limit dBm	Margin dB	Detector	Comment
1	*	3873.000	-70.00	14.37	-55.63	-13.00	-42.63	peak	

Test Mode | LTE Band 26_TX CH26740_1.4M

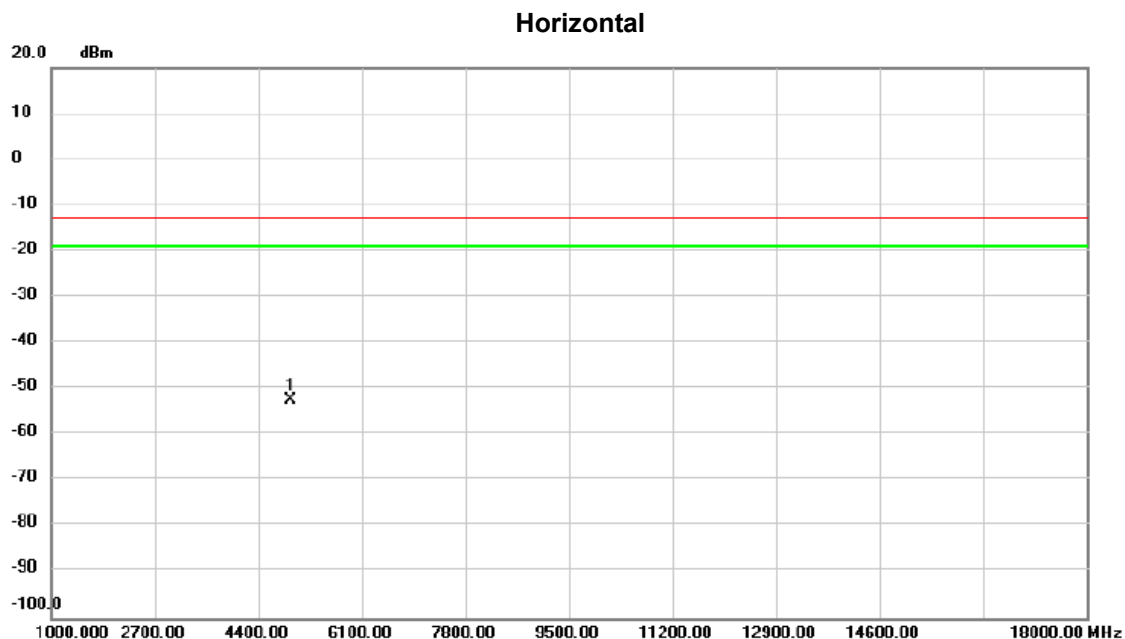

No.	Mk.	Freq.	Reading Level	Correct Factor	Measurement	Limit	Margin	Detector	Comment
		MHz	dBm	dB	dBm	dBm	dB		
1	*	4935.500	-69.95	17.53	-52.42	-13.00	-39.42	peak	

Test Mode	LTE Band 26_TX CH26740_5M
-----------	---------------------------

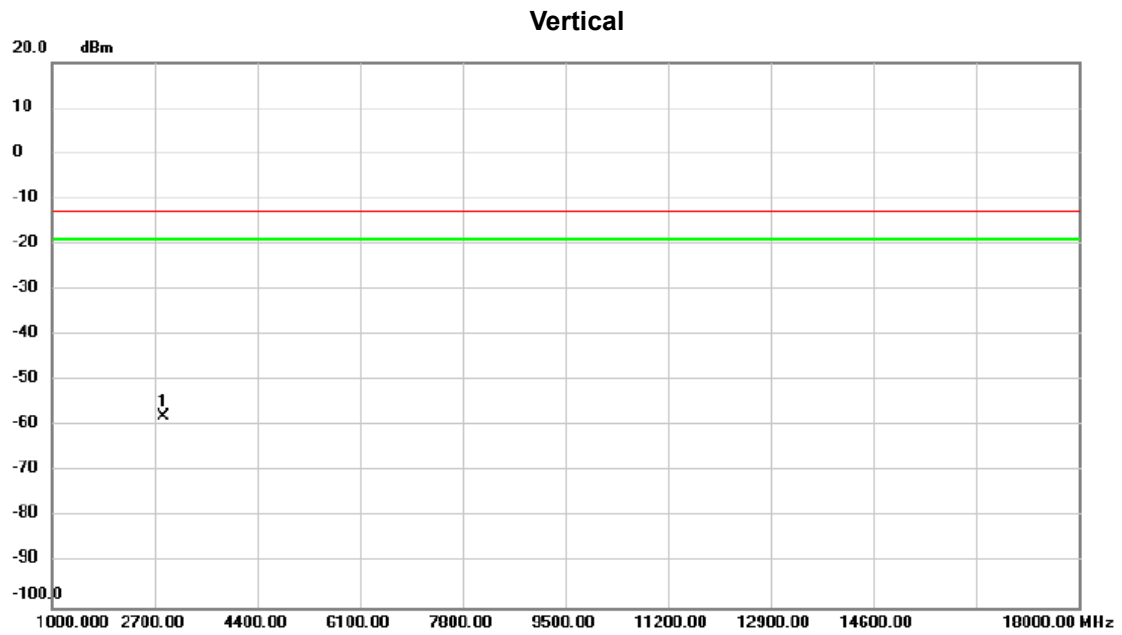

No.	Mk.	Freq.	Reading Level	Correct Factor	Measure-ment	Limit	Margin	Detector	Comment
		MHz	dBm	dB	dBm	dBm	dB		
1	*	2836.000	-69.14	11.35	-57.79	-13.00	-44.79	peak	

Test Mode | LTE Band 26_TX CH26740_5M

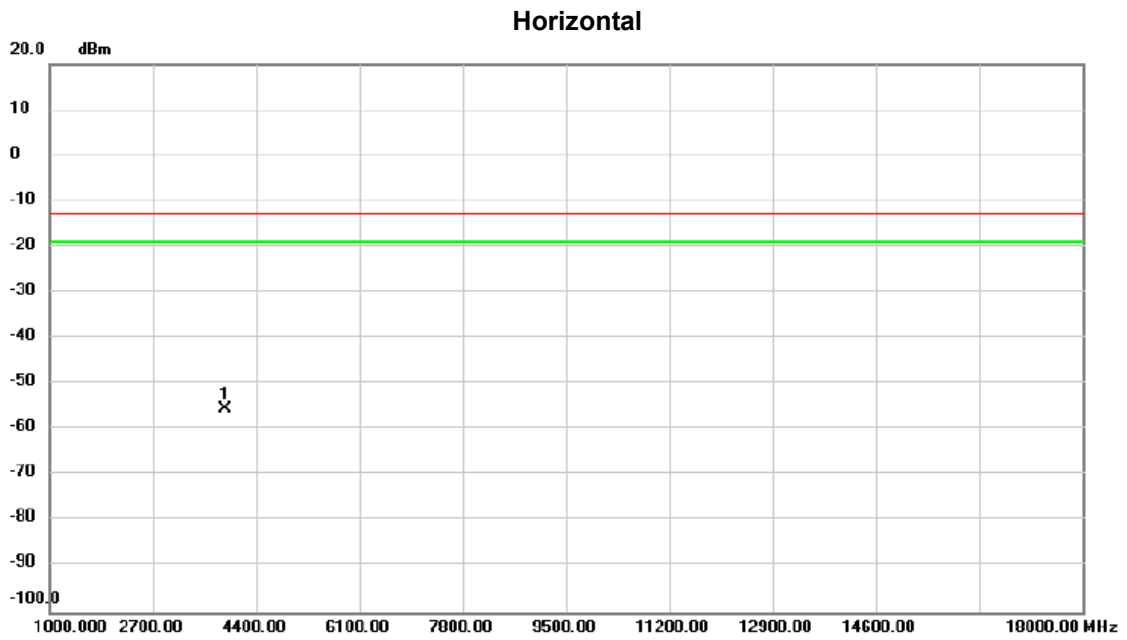

No. Mk.	Freq. MHz	Reading Level dBm	Correct Factor dB	Measure- ment dBm	Limit dBm	Margin dB	Detector	Comment
1 *	3890.000	-69.96	14.43	-55.53	-13.00	-42.53	peak	

Test Mode | LTE Band 26_TX CH26740_10M

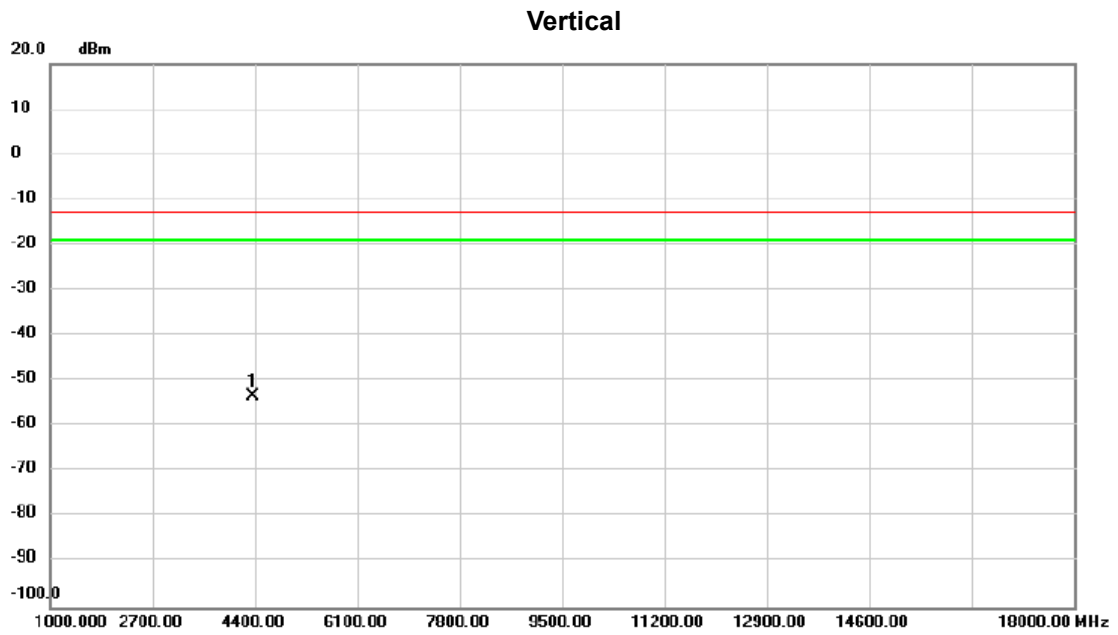

No.	Mk.	Freq. MHz	Reading Level dBm	Correct Factor dB	Measure- ment dBm	Limit dBm	Margin dB	Detector	Comment
1	*	4357.500	-68.52	15.16	-53.36	-13.00	-40.36	peak	

Test Mode | LTE Band 26_TX CH26740_10M

Horizontal

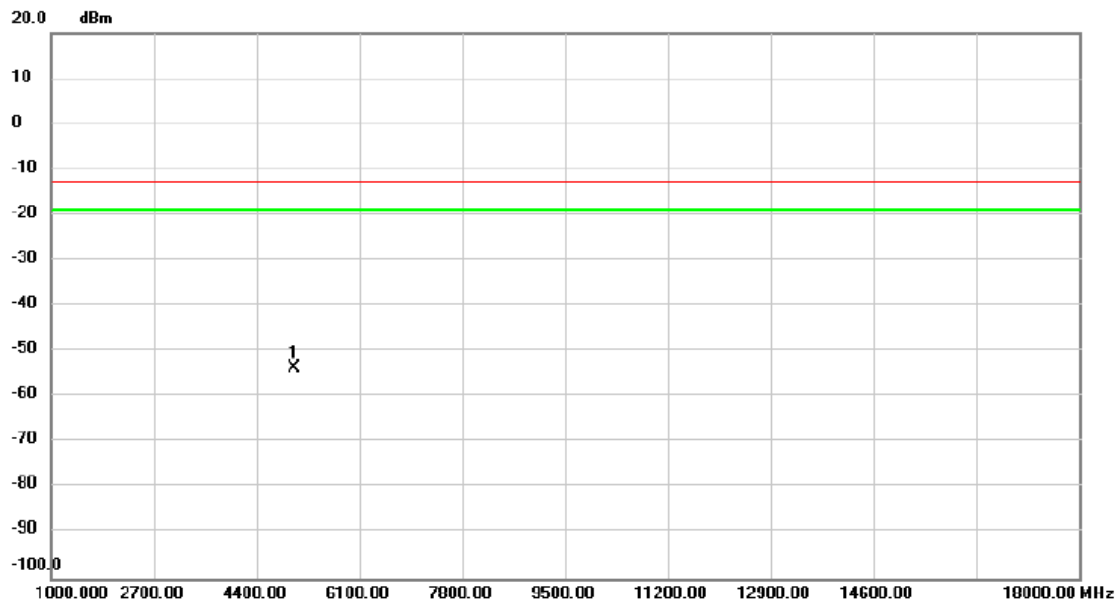

No.	Mk.	Freq. MHz	Reading Level dBm	Correct Factor dB	Measure- ment dBm	Limit dBm	Margin dB	Detector	Comment
1	*	5020.500	-71.66	17.88	-53.78	-13.00	-40.78	peak	

APPENDIX G - MASK

LTE Band 26_1.4M

1RB#0		1RB#5	
Channel	26697	Channel	26783

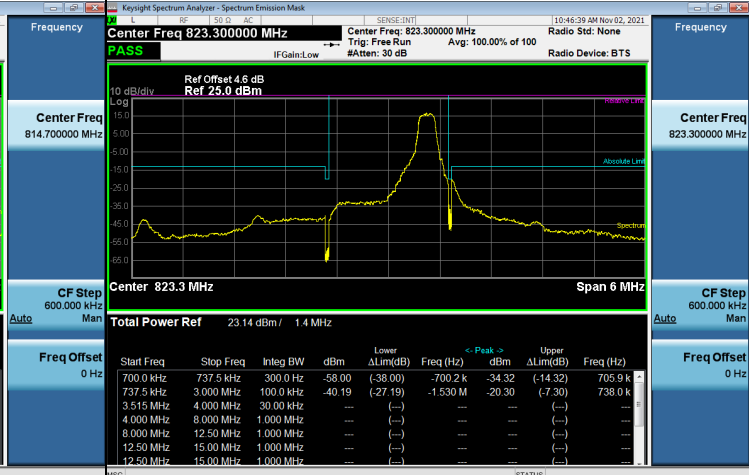
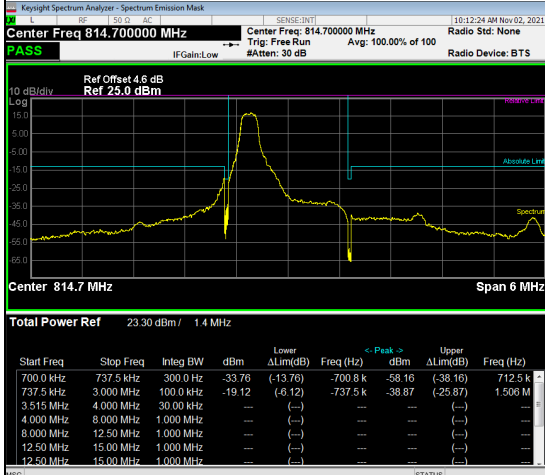

6RB#0		6RB#5	
Channel	26697	Channel	26783

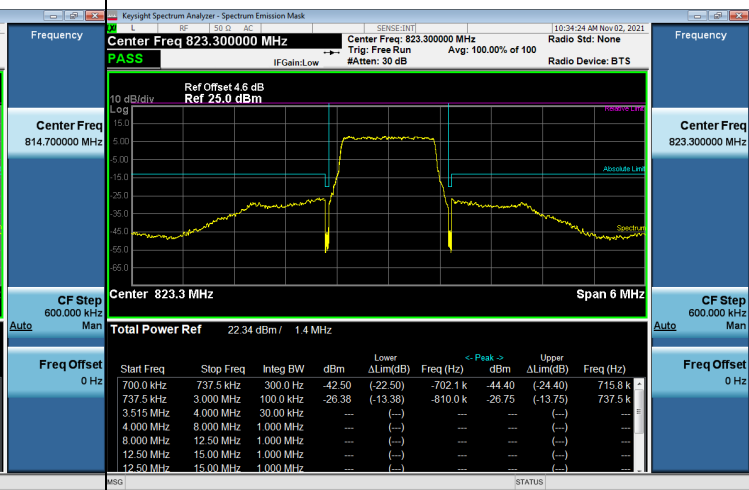
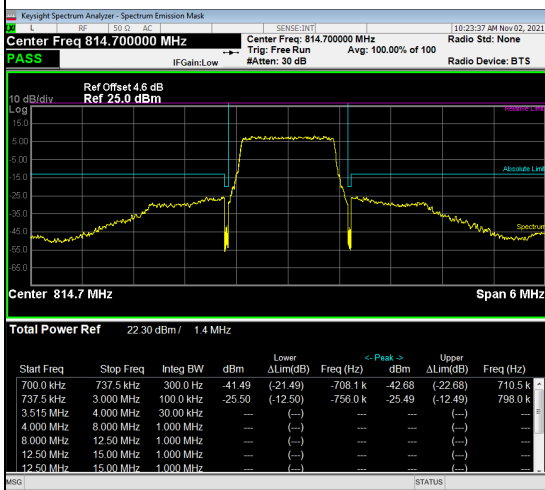

LTE Band 26_3M

1RB#0		1RB#14	
-------	--	--------	--

Channel	26705	Channel	26775
---------	-------	---------	-------

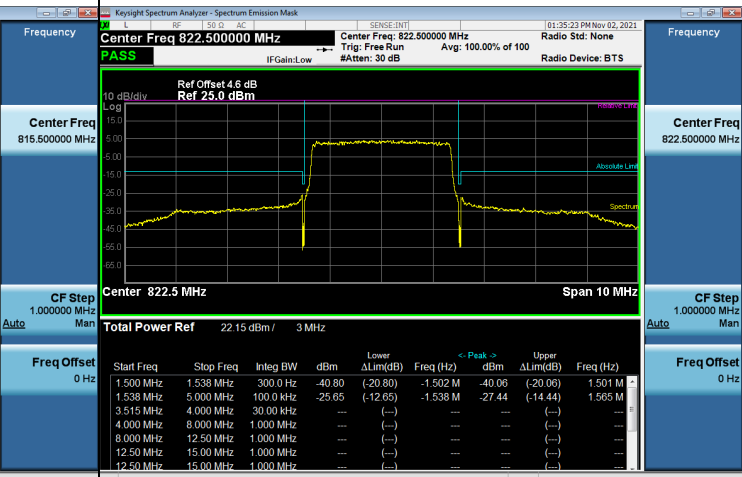
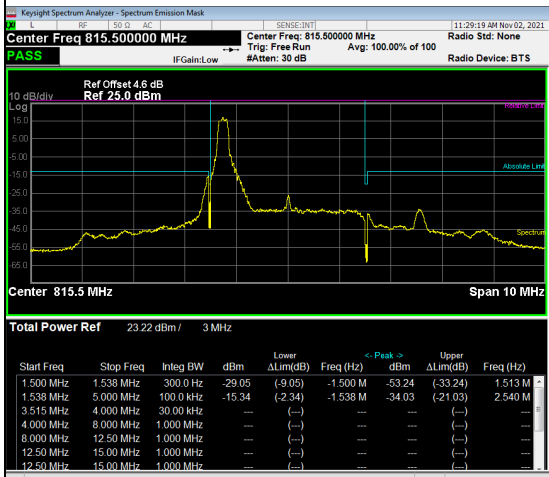

15RB#0

Channel		26705		Channel		26775	
---------	--	-------	--	---------	--	-------	--

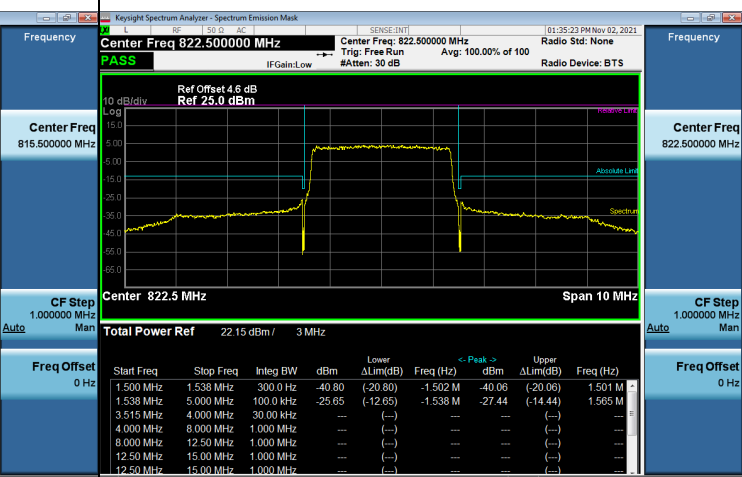
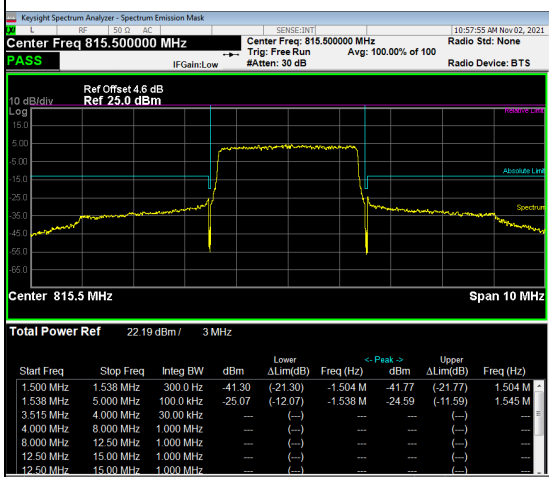

LTE Band 26_5M

1RB#0		1RB#24	
Channel	26715	Channel	26765

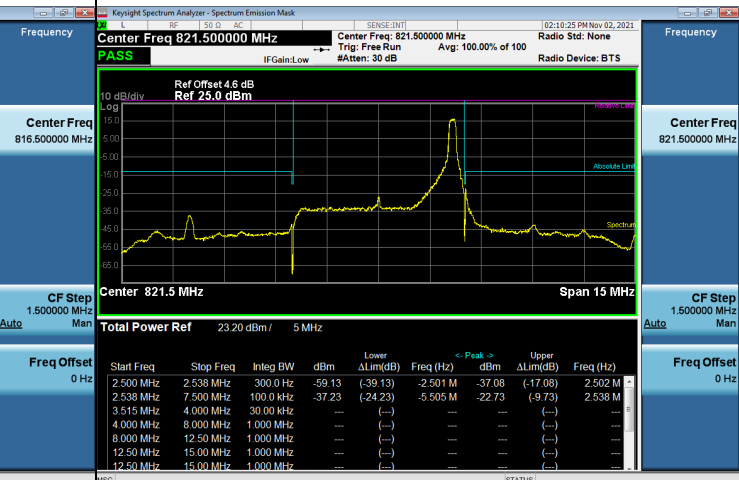
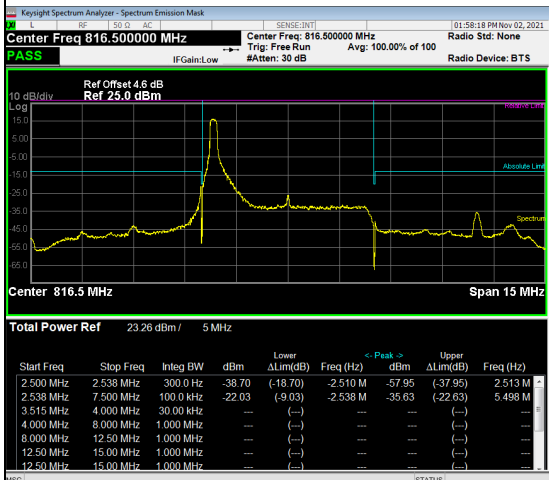

25RB#0

Channel		26715	Channel		26765
---------	--	-------	---------	--	-------

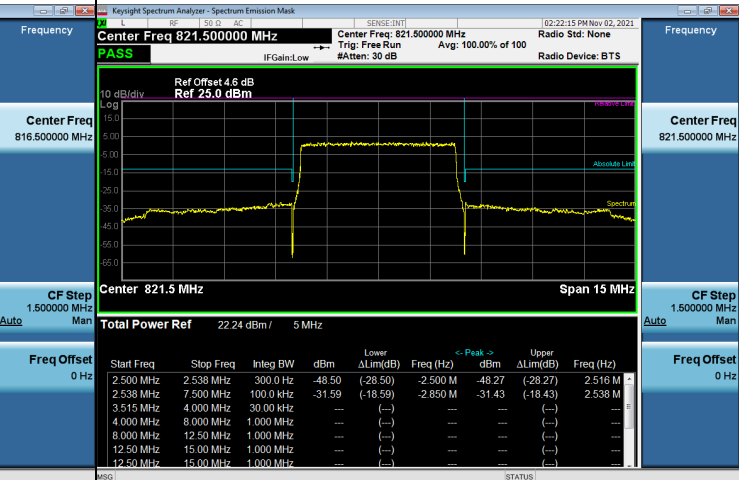
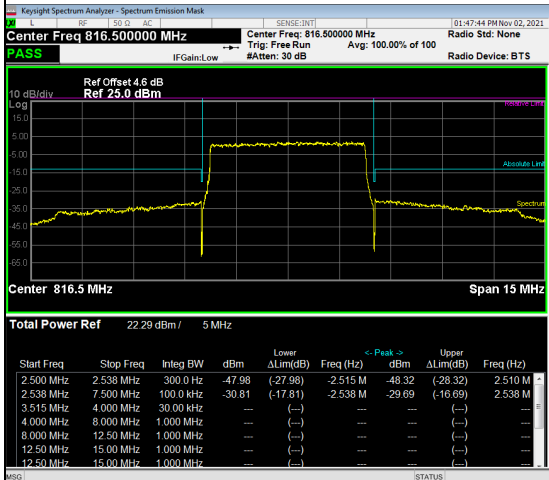

LTE Band 26_10M

1RB#0

1RB#49

Channel

26740

Channel

26740

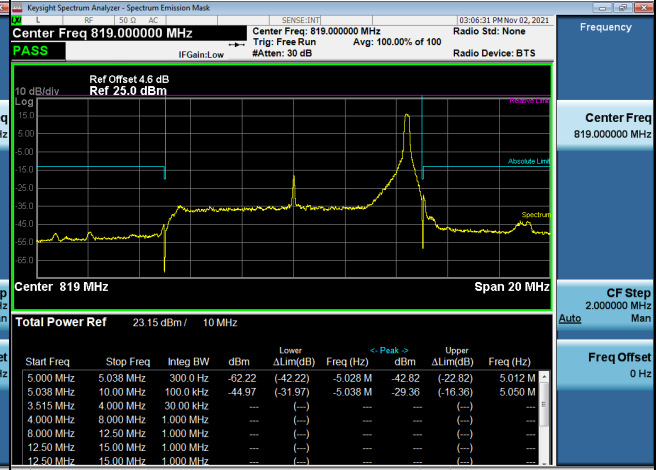
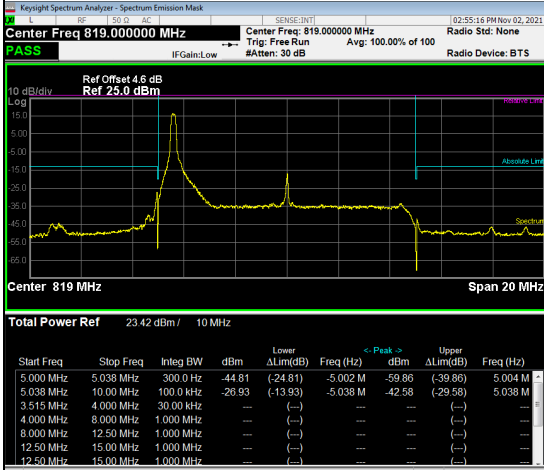

50RB#0

-

Channel

26740

-

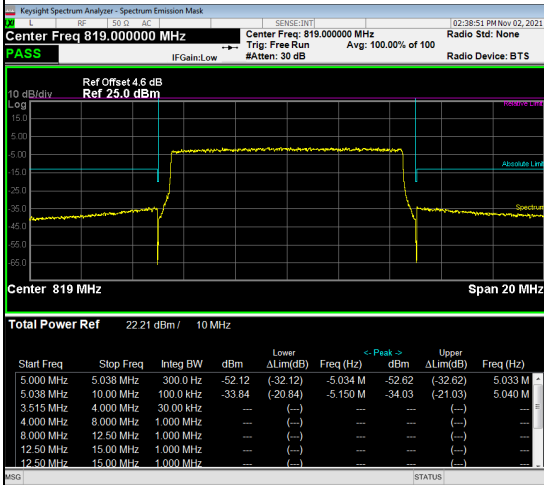

APPENDIX H - PEAK TO AVERAGE RATIO

LTE Band 26_1.4M Spectrum Plot

QPSK-26697

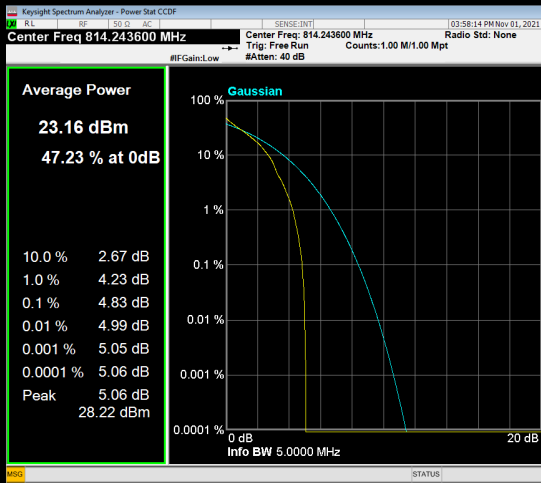

QPSK-26740

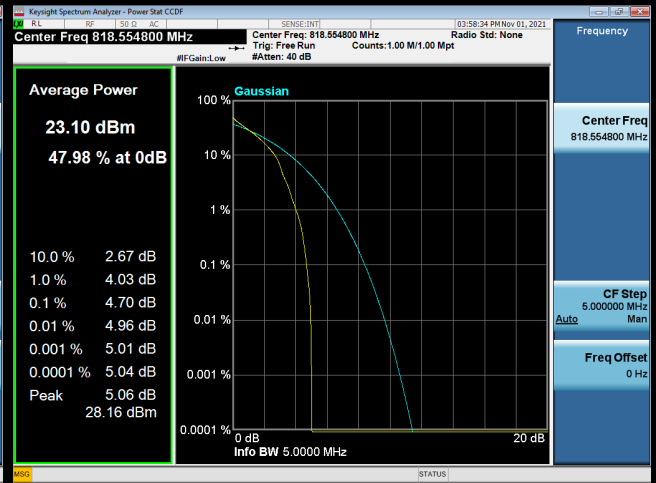

QPSK-26783

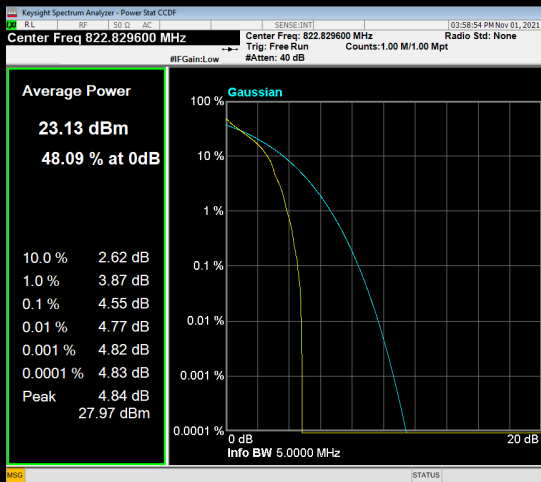

16QAM-26697

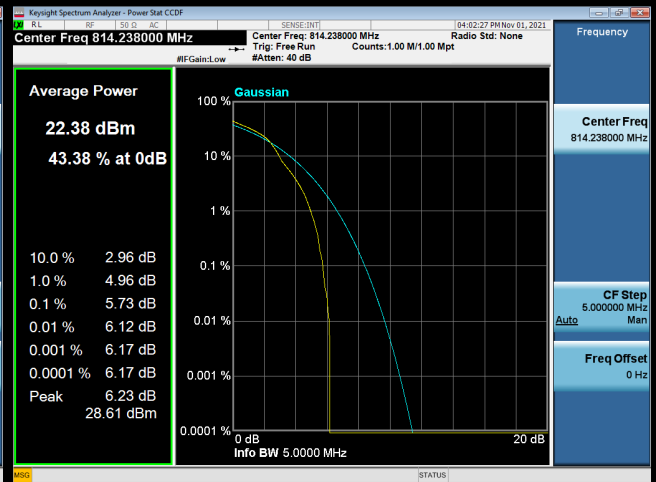

16QAM-26740

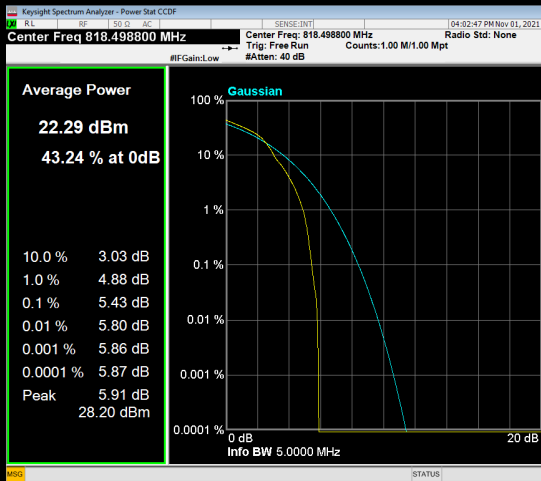

16QAM-26783

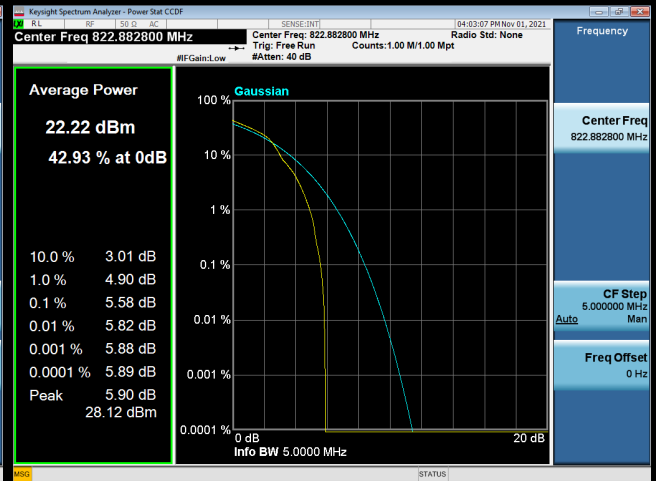

LTE Band 26_1.4M Spectrum Plot

64QAM-26697

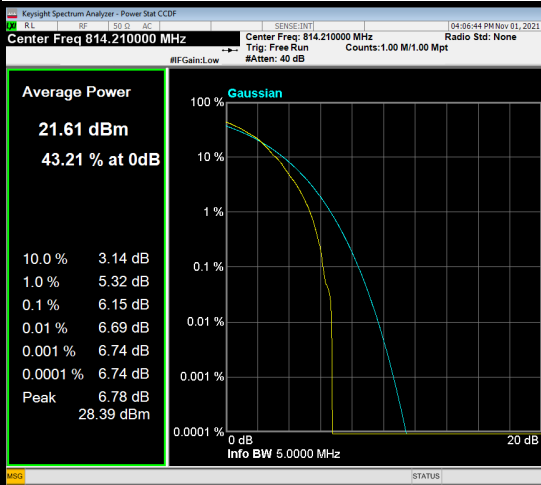

64QAM-26740

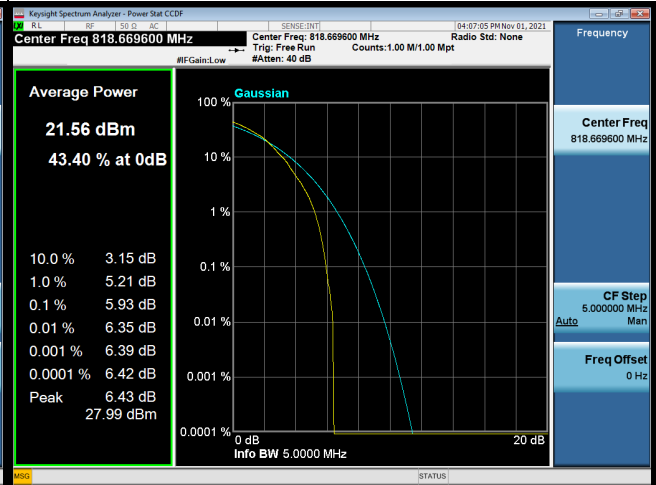

64QAM-26783

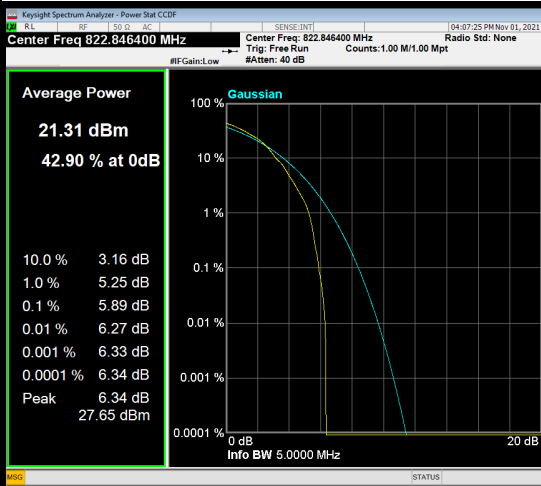

-

-

LTE Band 26_3M Spectrum Plot

QPSK-26705

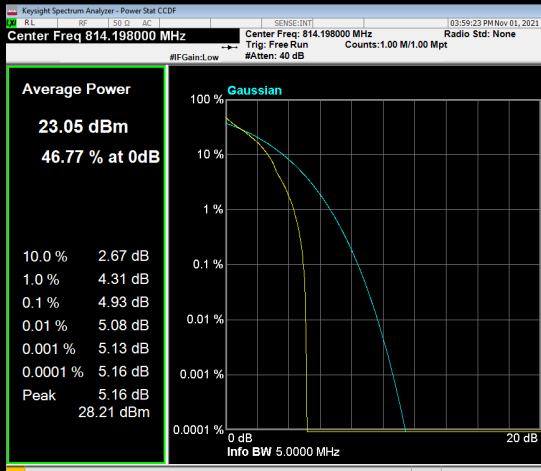

QPSK-26740

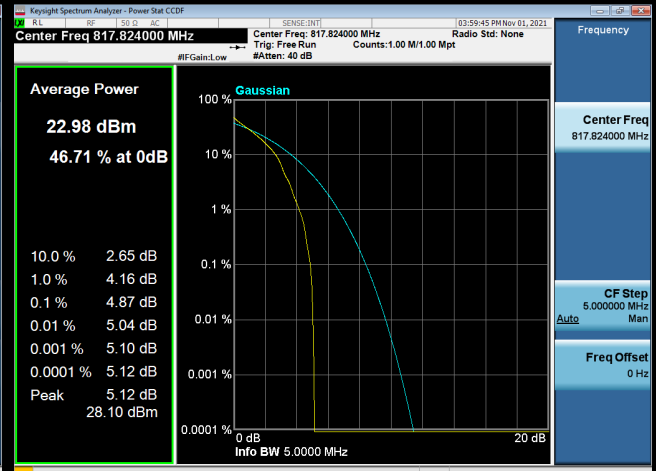

QPSK-26775

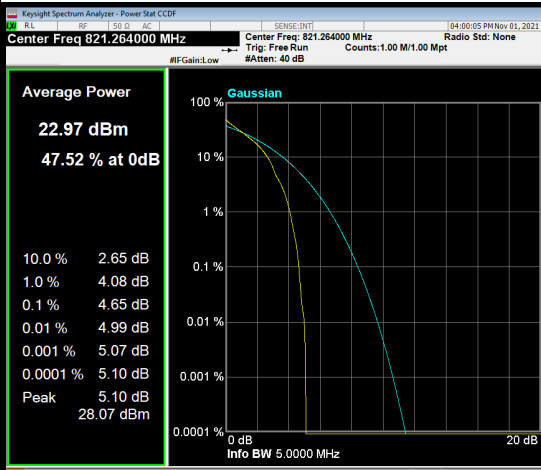

16QAM-26705

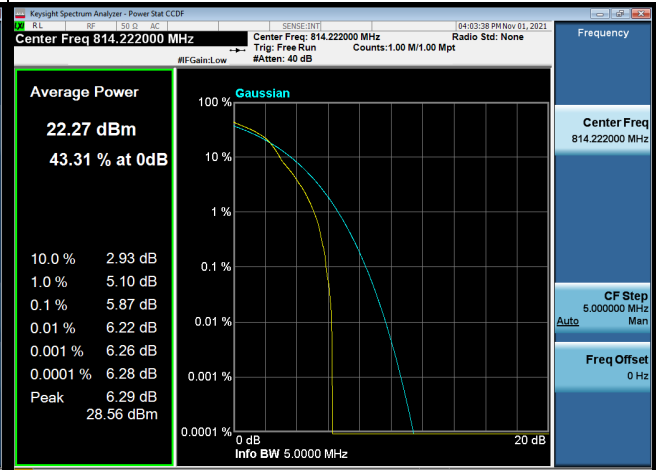

16QAM-26740

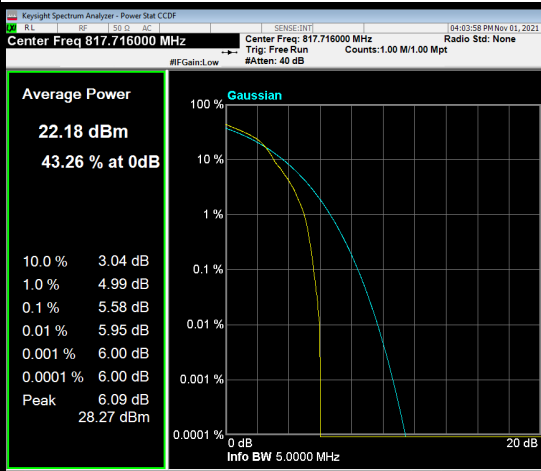

16QAM-26775

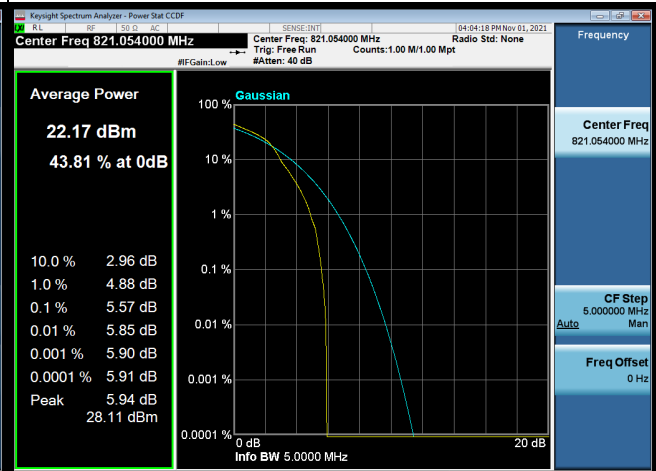

LTE Band 26_3M Spectrum Plot

64QAM-26705

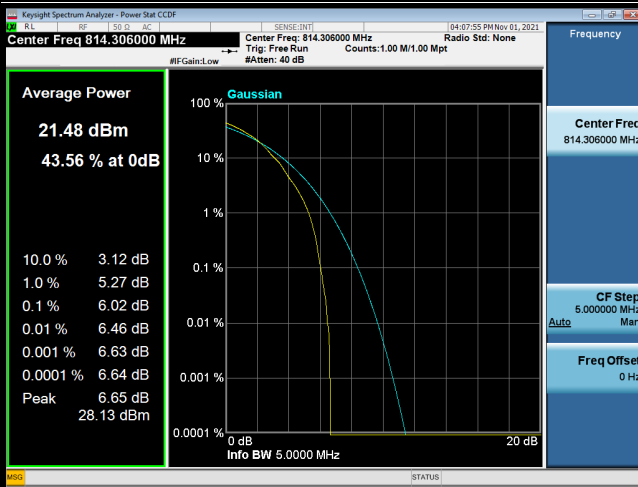

64QAM-26740

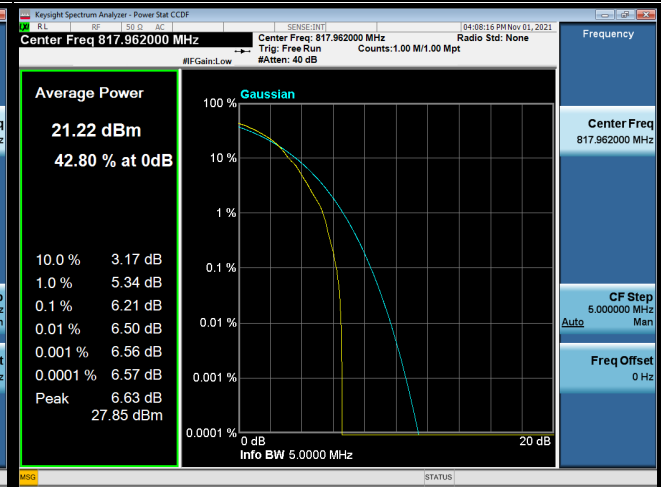

64QAM-26775

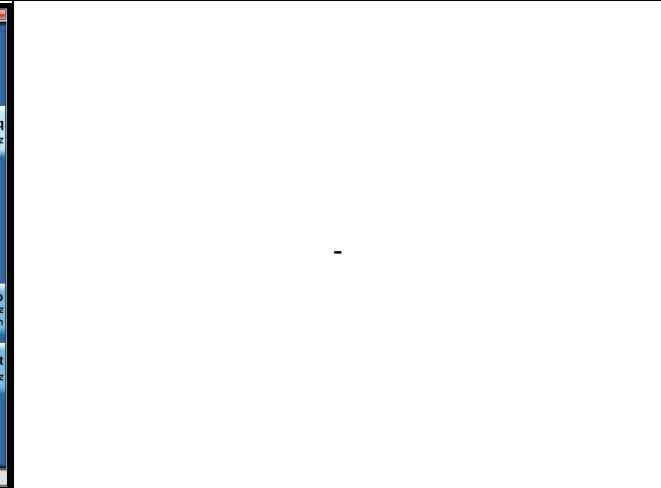
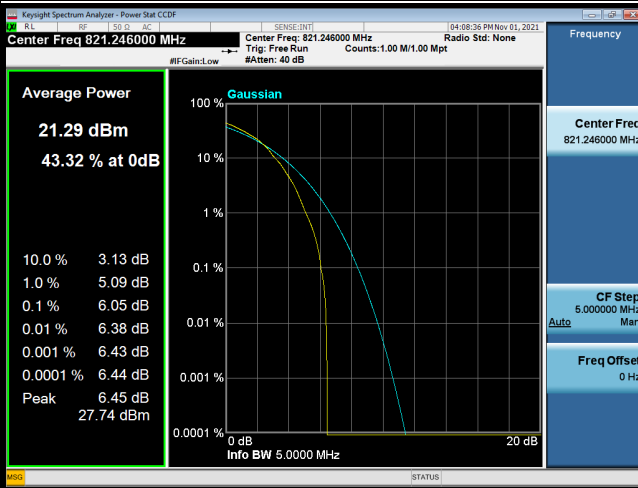

LTE Band 26_5M Spectrum Plot

QPSK-26715

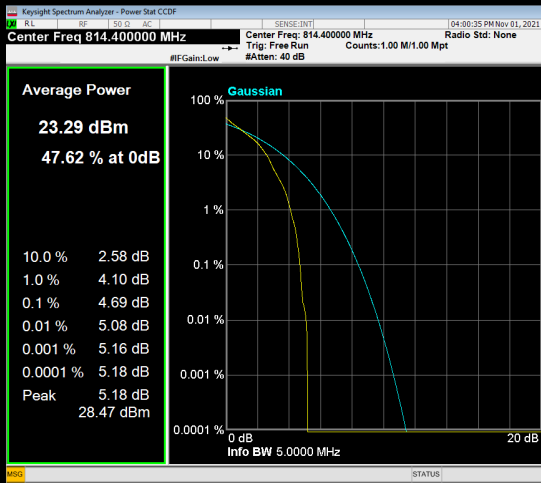

QPSK-26740

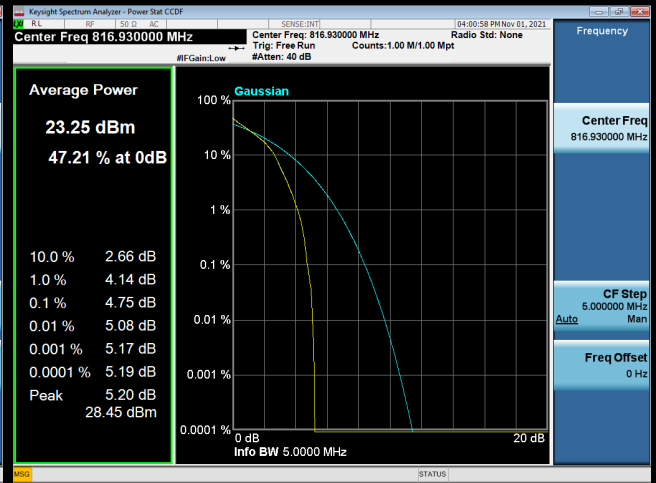

QPSK-26765

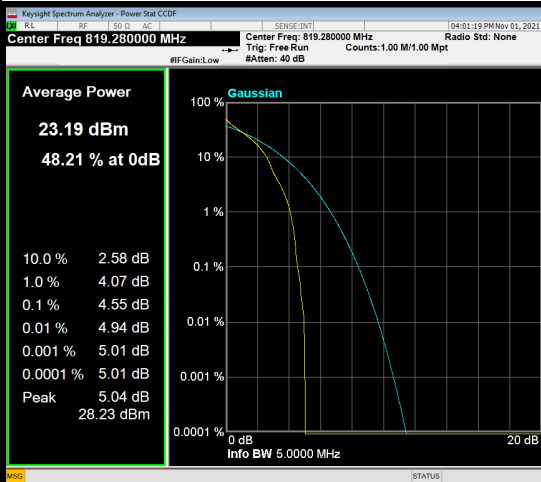

16QAM-26715

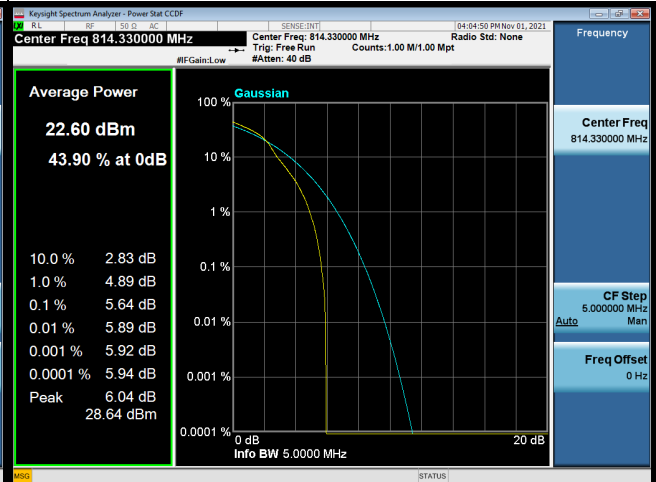

16QAM-26740

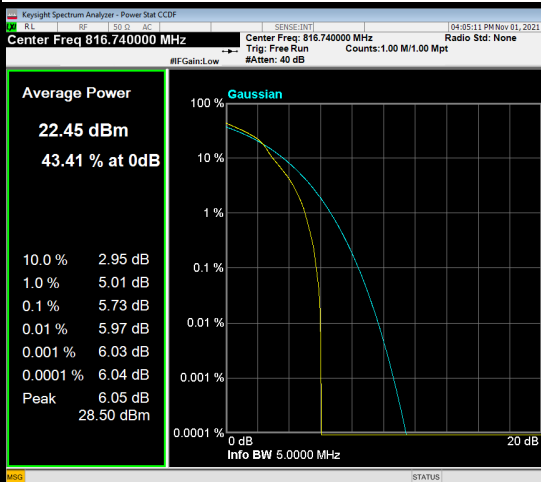

16QAM-26765

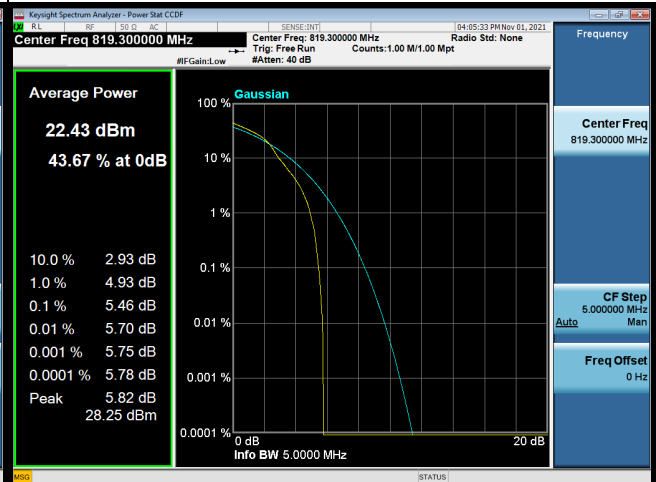

LTE Band 26_5M Spectrum Plot

64QAM-26715

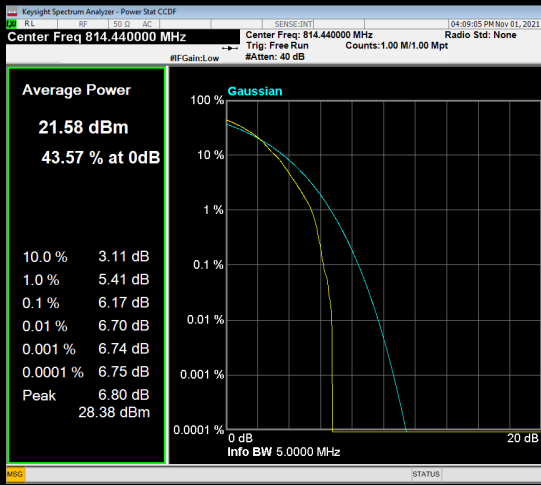

64QAM-26740

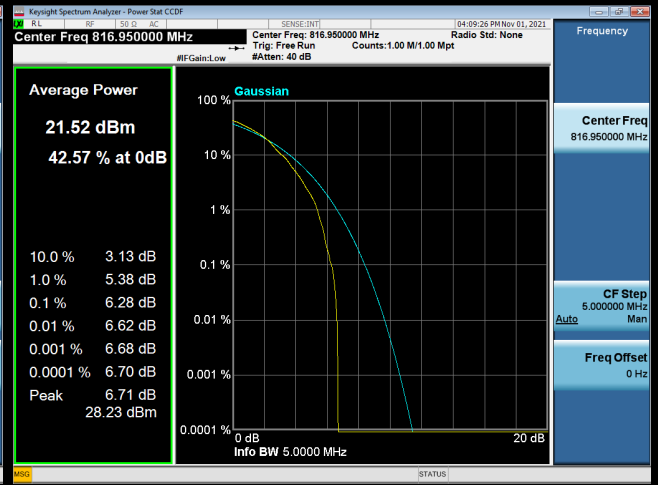

64QAM-26765

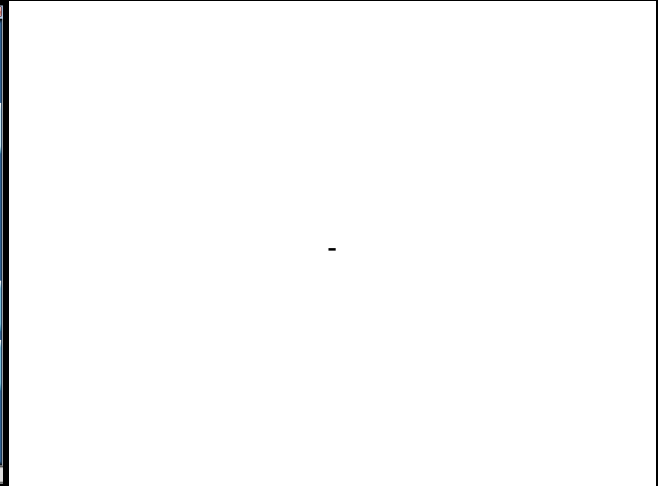
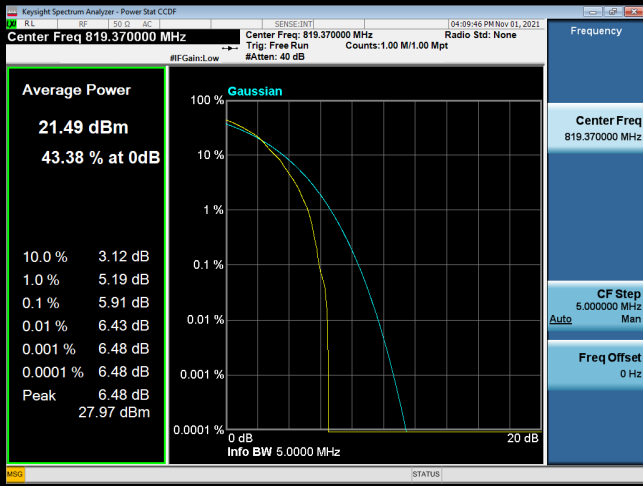

LTE Band 26_10M Spectrum Plot

QPSK-26740

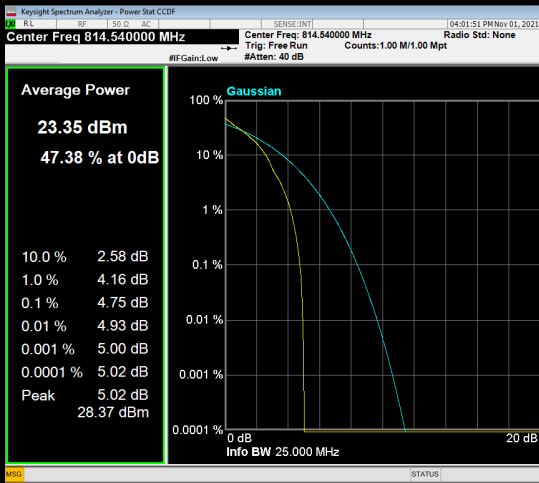

16QAM-26740

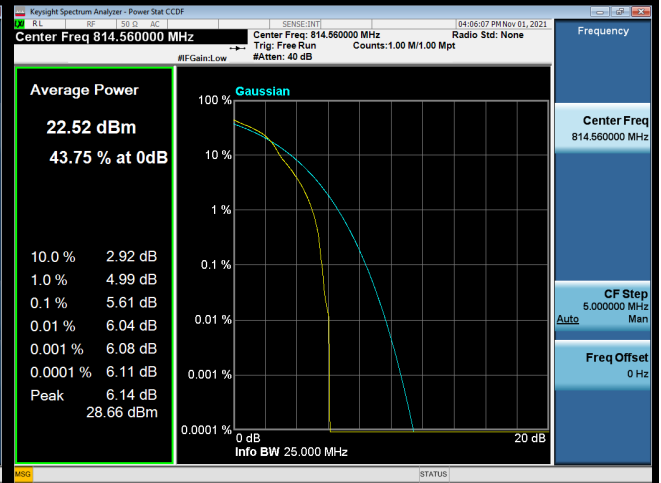

64QAM-26740

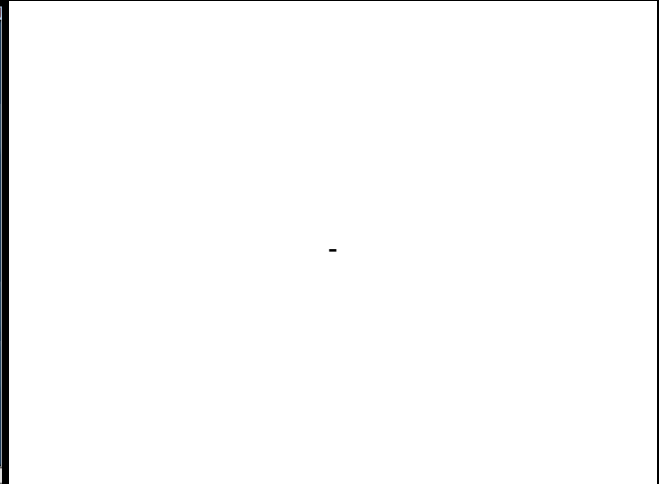
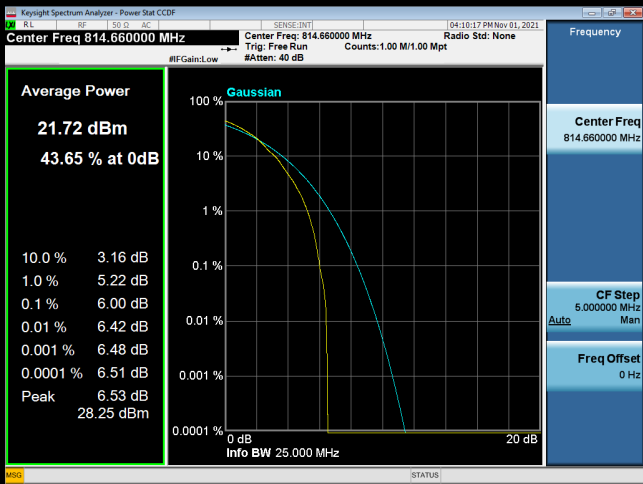

APPENDIX I - FREQUENCY STABILITY

Test Mode	LTE Band 26_CH26740_1.4M
-----------	--------------------------

Temperature vs. Frequency Stability

Temperature(°C)	Frequency Error (Hz)	Frequency Error (ppm)	Limit(ppm)
-30	2.06	0.002515263	±2.5
-20	1.57	0.001916972	
-10	-4.22	-0.005152625	
0	-5.19	-0.006336996	
10	5.16	0.006300366	
20	-0.13	-0.00015873	
30	3.17	0.003870574	
40	1.09	0.001330891	
50	0.61	0.000744811	
Max. Deviation (ppm)	-5.19	-0.006336996	

Voltage vs. Frequency Stability

Voltage(Volts)	Frequency Error (Hz)	Frequency Error (ppm)	Limit(ppm)
4.45	-2.31	-0.002820513	±2.5
3.87	3.44	0.004200244	
3.40	-2.58	-0.003150183	
Max. Deviation (ppm)	3.44	0.004200244	

Test Mode	LTE Band 26_CH26740_3M
-----------	------------------------

Temperature vs. Frequency Stability

Temperature(°C)	Frequency Error (Hz)	Frequency Error (ppm)	Limit(ppm)
-30	5.56	0.006788767	±2.5
-20	-5.49	-0.006703297	
-10	5.75	0.007020757	
0	4.81	0.005873016	
10	4.20	0.005128205	
20	4.30	0.005250305	
30	-0.42	-0.000512821	
40	-3.70	-0.004517705	
50	5.94	0.007252747	
Max. Deviation (ppm)	5.94	0.007252747	

Voltage vs. Frequency Stability

Voltage(Volts)	Frequency Error (Hz)	Frequency Error (ppm)	Limit(ppm)
4.45	-4.12	-0.005030525	±2.5
3.87	0.20	0.0002442	
3.40	4.76	0.005811966	
Max. Deviation (ppm)	4.76	0.005811966	

Test Mode	LTE Band 26_CH26740_5M
-----------	------------------------

Temperature vs. Frequency Stability

Temperature(°C)	Frequency Error (Hz)	Frequency Error (ppm)	Limit(ppm)
-30	-2.95	-0.003601954	±2.5
-20	-1.21	-0.001477411	
-10	1.91	0.002332112	
0	-0.65	-0.000793651	
10	5.72	0.006984127	
20	1.46	0.001782662	
30	5.98	0.007301587	
40	0.87	0.001062271	
50	3.45	0.004212454	
Max. Deviation (ppm)	5.98	0.007301587	

Voltage vs. Frequency Stability

Voltage(Volts)	Frequency Error (Hz)	Frequency Error (ppm)	Limit(ppm)
4.45	-5.11	-0.006239316	±2.5
3.87	4.42	0.005396825	
3.40	-1.86	-0.002271062	
Max. Deviation (ppm)	-5.11	-0.006239316	

Test Mode	LTE Band 26_CH26740_10M
-----------	-------------------------

Temperature vs. Frequency Stability

Temperature(°C)	Frequency Error (Hz)	Frequency Error (ppm)	Limit(ppm)
-30	3.31	0.004041514	±2.5
-20	-1.01	-0.001233211	
-10	-1.34	-0.001636142	
0	-2.47	-0.003015873	
10	3.89	0.004749695	
20	3.05	0.003724054	
30	2.93	0.003577534	
40	4.79	0.005848596	
50	-3.50	-0.004273504	
Max. Deviation (ppm)	4.79	0.005848596	

Voltage vs. Frequency Stability

Voltage(Volts)	Frequency Error (Hz)	Frequency Error (ppm)	Limit(ppm)
4.45	3.77	0.004603175	±2.5
3.87	0.61	0.000744811	
3.40	-5.42	-0.006617827	
Max. Deviation (ppm)	-5.42	-0.006617827	

End of Test Report