

SAR Dipole

Performance
Measurement
Report

ISSUED BY
Shenzhen BALUN Technology Co., Ltd.



FOR
Validation Dipoles

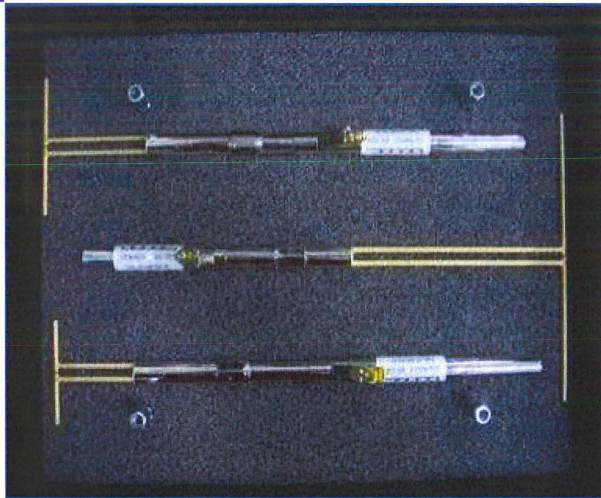

Tested by: 
Zong Liyao
(Engineer)

Approved by: 
Liao Jianming
(Technical Director)



Report No.: LW-SZ2060015-701
EUT Type: SAR Validation Dipole
Model Name: D835V2, D1750V2
D1900V2, D2450V2, D2600V2
Brand Name: Speag
Test Conclusion: Pass
Test Date: Sep. 12, 2019 ~ Jun 02, 2020
Date of Issue: Jun 03, 2020

NOTE: This test report can be duplicated completely for the legal use with the approval of the applicant; it shall not be reproduced except in full, without the written approval of Shenzhen BALUN Technology Co., Ltd. BALUN Laboratory. Any objections should be raised within thirty days from the date of issue. To validate the report, please contact us.

Block B, 1st FL, Baisha Science and Technology Park, Shahe Xi Road, Nanshan District, Shenzhen, Guangdong, P. R. China 518055
TEL: +86-755-66850100, FAX: +86-755-61824271
Email: info@baluntek.com
www.baluntek.com



1 GENERAL INFORMATION

1.1 Introduction

This document contains a summary of the requirements set forth by the IEEE 1528, FCC KDB 865664 D01 for reference dipoles used for SAR measurement system validations. Instead of the typical annual calibration recommended by measurement standards, the reference dipoles were demonstrated that the SAR target, impedance and return loss have remain stable, so the longer calibration interval is acceptable.

1.2 General Description for Equipment under Test (EUT)

EUT Type	DASY 5 Reference Dipoles
Manufacturer	Speag

Parameter	EUT 2	EUT 3	EUT 4	EUT 5	EUT 6
Model	D835V2	D1750V2	D1900V2	D2450V2	D2600V2
Frequency	835 MHz	1750 MHz	1900 MHz	2450MHz	2600 MHz
Serial Number	SN 4d187	SN 1130	SN 5d193	SN 952	SN 1095
Product Condition (New/ Used)	Used	Used	Used	Used	Used
Last Cal. Date	2019/6/11	2018/09/13	2019/6/11	2019/6/10	2018/11/05
Current meas. Date	2020/6/01	2019/09/12	2020/6/01	2020/6/02	2019/11/04



1.3EUT Photos

D835V2



D1750V2



D1900V2



D2450V2



D2600V2





2 DIPOLE IMPEDANCE AND RETURN LOSS

The dipoles are designed to have low return loss when presented against a flat phantom at the specified distance. A Vector Network Analyser was used to perform a return loss measurement on the specific dipole when in the measurement location against the phantom and the distance was specified by the manufacturer with a special, low loss and low relative permittivity spacer.

The impedance was measured at the SMA-connector with the network analyser.

The measurement of verification with return loss should not deviate by more than 20% and minimum of 20 dB of the return loss, and the impedance (real or imaginary parts) should not deviate by more than 5 Ohms from the previous measurement using network analyzer.

Note:

The "Previous Meas." in the following table refer to dipoles or other equivalent RF sources calibration reports.



2.1 D835V2

RETURN LOSS AND IMPEDANCE IN HEAD LIQUID

Meas. Results	Current Meas.	Previous Meas.	Max. Deviation
Return Loss(dB)	-30.227	-28.95	-4.41%
Impedance	47.953Ω - 0.843 jΩ	51.919 Ω - 3.091jΩ	-3.966Ω (Real part)

Return Loss

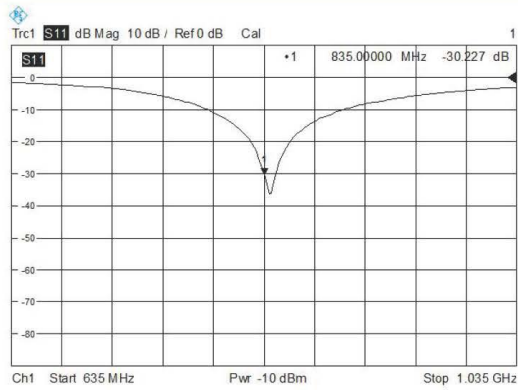

Impedance

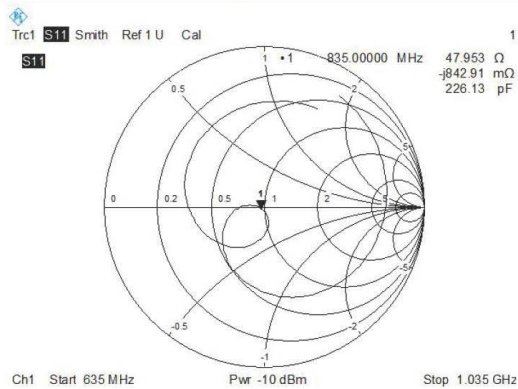



RETURN LOSS AND IMPEDANCE IN BODY LIQUID

Meas. Results	Current Meas.	Previous Meas.	Max. Deviation
Return Loss(dB)	-24.238	-24.864	2.518%
Impedance	46.906 Ω - 0.336 $j\Omega$	47.302 Ω - 4.868 $j\Omega$	4.532 Ω (Imaginary part)

Return Loss

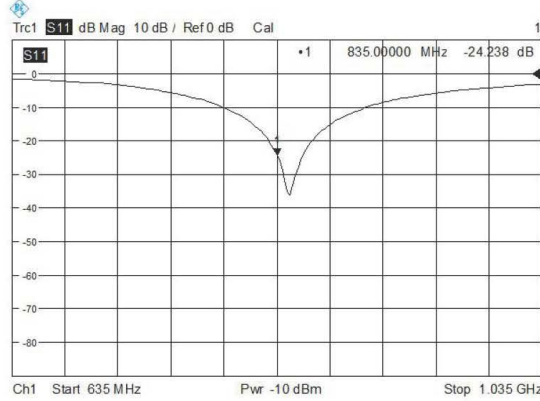

Impedance

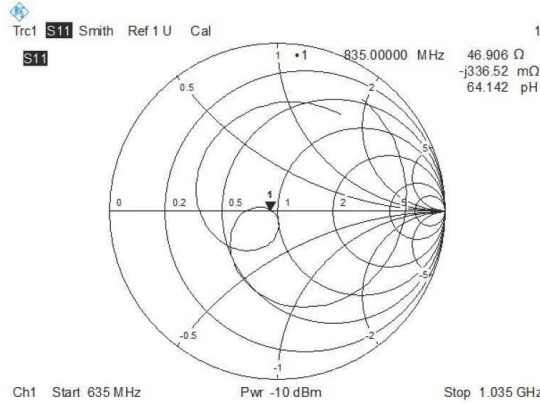



2.23.3 D1750V2

RETURN LOSS AND IMPEDANCE IN HEAD LIQUID

Meas. Results	Current Meas.	Previous Meas.	Max. Deviation
Return Loss(dB)	-34.478	-32.43	6.32%
Impedance	47.096 Ω -0.334 j Ω	50.193 Ω - 2.388 j Ω	3.097 Ω (Real part)

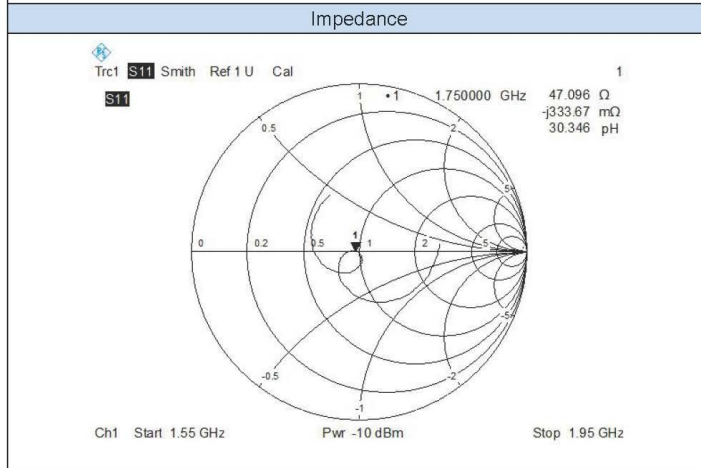
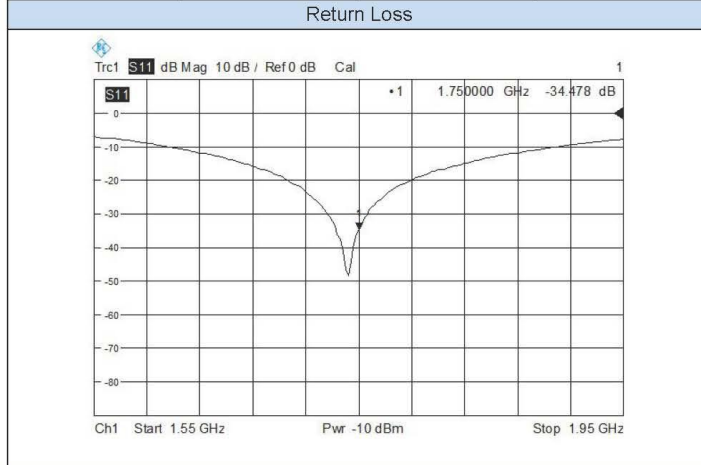



RETURN LOSS AND IMPEDANCE IN BODY LIQUID

Meas. Results	Current Meas.	Previous Meas.	Max. Deviation
Return Loss(dB)	-25.272	-24.825	1.81%
Impedance	46.763 Ω +0.612 j Ω	45.20 Ω - 2.611 j Ω	3.223 Ω (Real part)

Return Loss

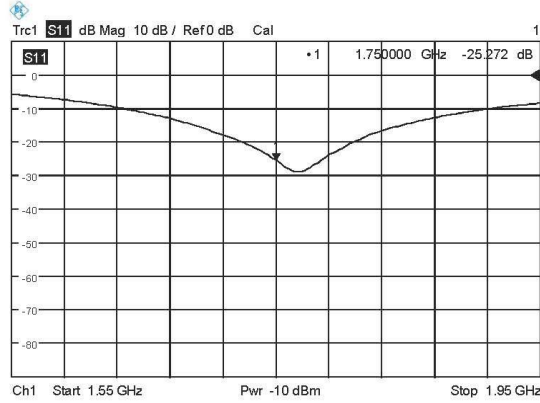

Impedance

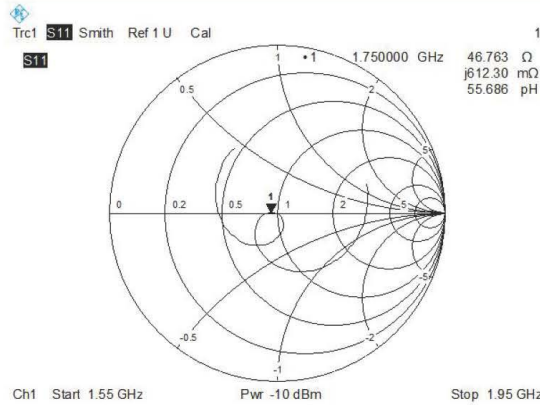



2.3D1900V2

RETURN LOSS AND IMPEDANCE IN HEAD LIQUID

Meas. Results	Current Meas.	Previous Meas.	Max. Deviation
Return Loss(dB)	-24.945	-24.339	2.49%
Impedance	47.949 Ω + 4.221 $j\Omega$	51.748 Ω + 5.933 $j\Omega$	3.799 Ω (Real part)

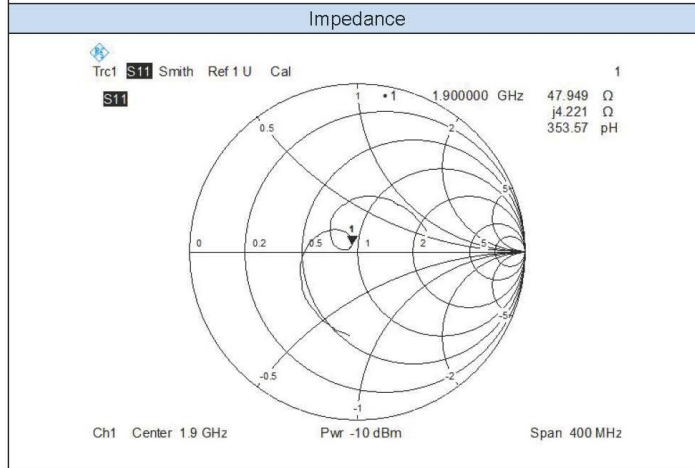
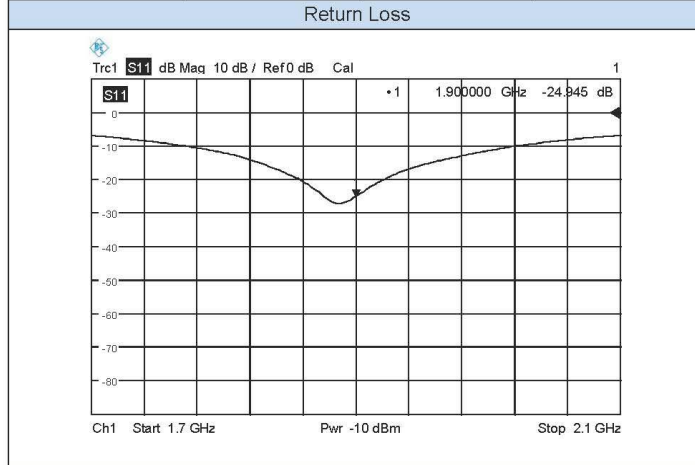



RETURN LOSS AND IMPEDANCE IN BODY LIQUID

Meas. Results	Current Meas.	Previous Meas.	Max. Deviation
Return Loss(dB)	-25.822	-24.704	4.53%
Impedance	48.893 Ω + 5.253 $j\Omega$	47.771 Ω + 5.242 $j\Omega$	1.122 Ω (Real part)

Return Loss

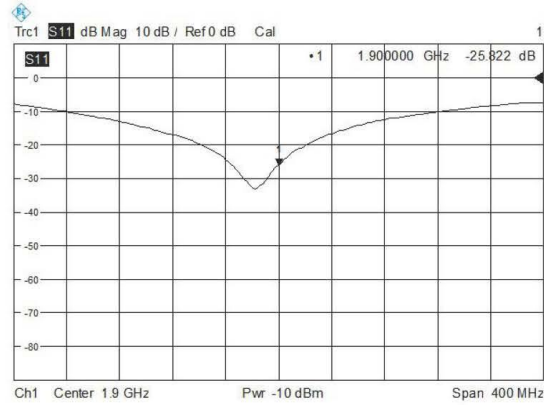

Impedance

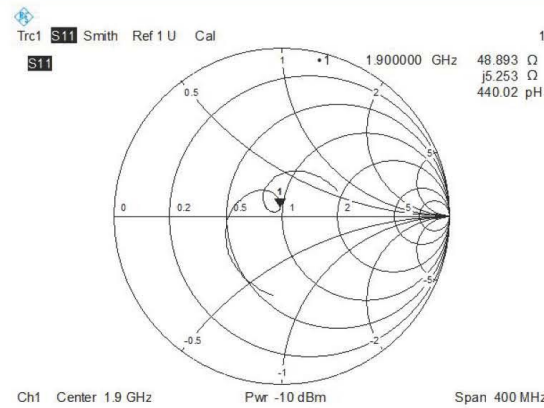



2.4D2450V2

RETURN LOSS AND IMPEDANCE IN HEAD LIQUID

Meas. Results	Current Meas.	Previous Meas.	Max. Deviation
Return Loss(dB)	-27.485	-26.753	2.74%
Impedance	49.517 Ω + 1.508 $j\Omega$	54.071 Ω + 2.513 $j\Omega$	4.554 Ω (Real part)

Return Loss

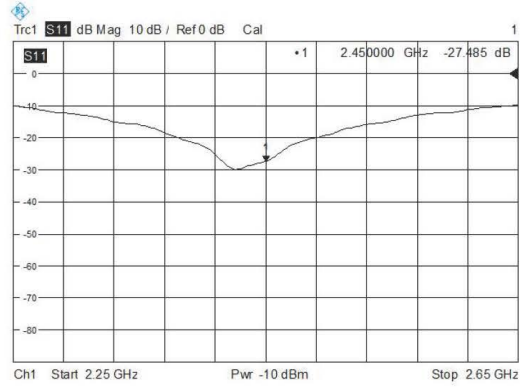

Impedance

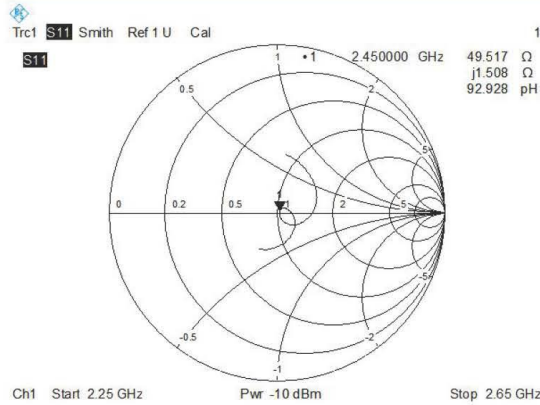



RETURN LOSS AND IMPEDANCE IN BODY LIQUID

Meas. Results	Current Meas.	Previous Meas.	Max. Deviation
Return Loss (dB)	-28.012	-27.882	0.47%
Impedance	49.496 Ω + 1.998 $j\Omega$	52.349 Ω + 3.40 $j\Omega$	2.853 Ω (Imaginary part)

Return Loss

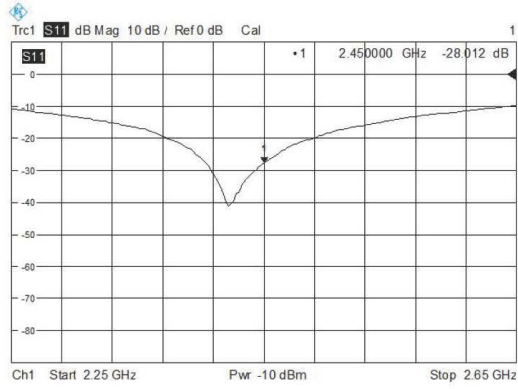

+Impedance

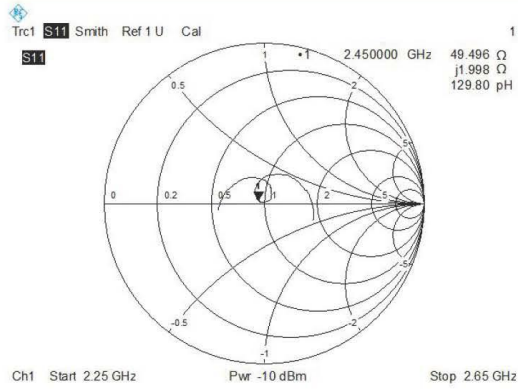



2.5 D2600V2

RETURN LOSS AND IMPEDANCE IN HEAD LIQUID

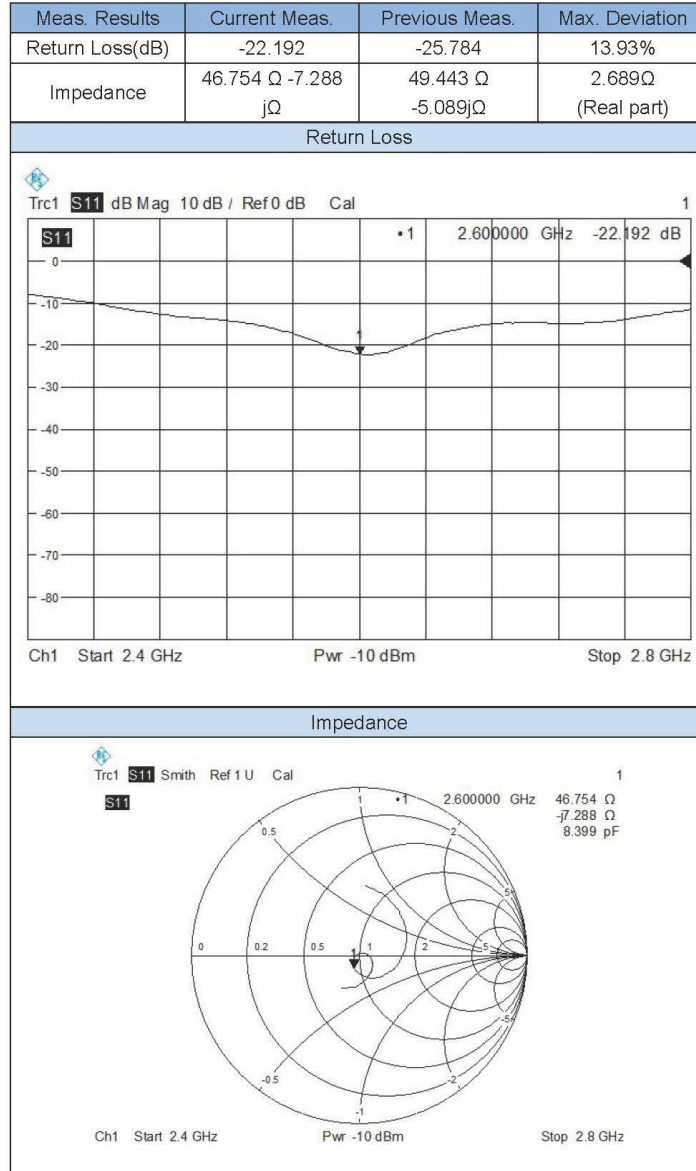



RETURN LOSS AND IMPEDANCE IN BODY LIQUID

Meas. Results	Current Meas.	Previous Meas.	Max. Deviation
Return Loss(dB)	-22.192	-23.544	5.74%
Impedance	46.334 Ω -j5.883 j Ω	46.722 Ω -5.546 j Ω	0.388 Ω (Real part)

Return Loss

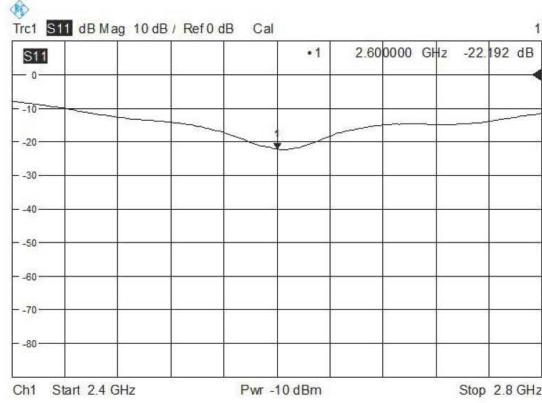

Impedance

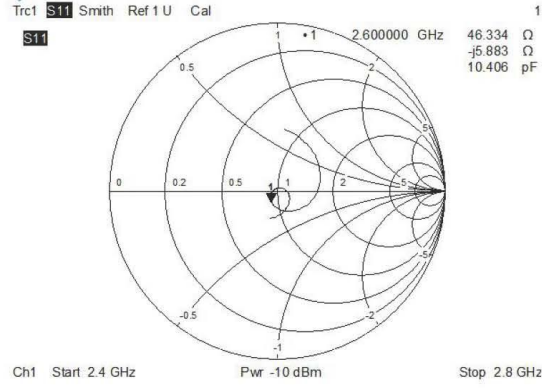

--END OF REPORT--