

FCC Test Report

Report No.: RF190910E04-1

FCC ID: 2AUYB-TXXX

Test Model: TLP3-71300-5120-24-T

Received Date: Sep. 10, 2019

Test Date: Sep. 19 to 25, 2019

Issued Date: Oct. 17, 2019

Applicant: Leonton Technologies Co., Ltd.

Address: 9F-1., No. 43, Fuxing Rd., Xindian Dist., New Taipei City 231, Taiwan

Issued By: Bureau Veritas Consumer Products Services (H.K.) Ltd., Taoyuan Branch
Hsin Chu Laboratory

Lab Address: E-2, No.1, Li Hsin 1st Road, Hsinchu Science Park, Hsinchu City 300,
Taiwan

Test Location: E-2, No.1, Li Hsin 1st Road, Hsinchu Science Park, Hsinchu City 300,
Taiwan

**FCC Registration /
Designation Number:** 723255 / TW2022



This report is for your exclusive use. Any copying or replication of this report to or for any other person or entity, or use of our name or trademark, is permitted only with our prior written permission. This report sets forth our findings solely with respect to the test samples identified herein. The results set forth in this report are not indicative or representative of the quality or characteristics of the lot from which a test sample was taken or any similar or identical product unless specifically and expressly noted. Our report includes all of the tests requested by you and the results thereof based upon the information that you provided to us. You have 60 days from date of issuance of this report to notify us of any material error or omission caused by our negligence, provided, however, that such notice shall be in writing and shall specifically address the issue you wish to raise. A failure to raise such issue within the prescribed time shall constitute your unqualified acceptance of the completeness of this report, the tests conducted and the correctness of the report contents. Unless specific mention, the uncertainty of measurement has been explicitly taken into account to declare the compliance or non-compliance to the specification. The report must not be used by the client to claim product certification, approval, or endorsement by TAF or any government agencies.

Table of Contents

Release Control Record	4
1 Certificate of Conformity	5
2 Summary of Test Results	6
2.1 Measurement Uncertainty	6
2.2 Modification Record	6
3 General Information	7
3.1 General Description of EUT	7
3.2 Description of Test Modes	9
3.2.1 Test Mode Applicability and Tested Channel Detail	10
3.3 Duty Cycle of Test Signal	12
3.4 Description of Support Units	13
3.4.1 Configuration of System under Test	14
3.5 General Description of Applied Standard	16
4 Test Types and Results	17
4.1 Radiated Emission and Bandedge Measurement	17
4.1.1 Limits of Radiated Emission and Bandedge Measurement	17
4.1.2 Test Instruments	18
4.1.3 Test Procedure	20
4.1.4 Deviation from Test Standard	20
4.1.5 Test Setup	21
4.1.6 EUT Operating Condition	22
4.1.7 Test Results	23
4.2 Conducted Emission Measurement	43
4.2.1 Limits of Conducted Emission Measurement	43
4.2.2 Test Instruments	43
4.2.3 Test Procedure	44
4.2.4 Deviation from Test Standard	44
4.2.5 Test Setup	44
4.2.6 EUT Operating Condition	44
4.2.7 Test Results	45
4.3 Transmit Power Measurement	47
4.3.1 Limits of Transmit Power Measurement	47
4.3.2 Test Setup	48
4.3.3 Test Instruments	48
4.3.4 Test Procedure	48
4.3.5 Deviation from Test Standard	48
4.3.6 EUT Operating Condition	48
4.3.7 Test Result	49
4.4 Occupied Bandwidth Measurement	51
4.4.1 Test Setup	51
4.4.2 Test Instruments	51
4.4.3 Test Procedure	51
4.4.4 Test Results	52
4.5 Peak Power Spectral Density Measurement	58
4.5.1 Limits of Peak Power Spectral Density Measurement	58
4.5.2 Test Setup	58
4.5.3 Test Instruments	58
4.5.4 Test Procedure	58
4.5.5 Deviation from Test Standard	58
4.5.6 EUT Operating Condition	58
4.5.7 Test Results	59
4.6 Frequency Stability Measurement	65
4.6.1 Limits of Frequency Stability Measurement	65

4.6.2	Test Setup.....	65
4.6.3	Test Instruments	65
4.6.4	Test Procedure	65
4.6.5	Deviation from Test Standard	65
4.6.6	EUT Operating Condition	65
4.6.7	Test Results	66
4.7	6dB Bandwidth Measurement	67
4.7.1	Limits of 6dB Bandwidth Measurement.....	67
4.7.2	Test Setup.....	67
4.7.3	Test Instruments	67
4.7.4	Test Procedure	67
4.7.5	Deviation from Test Standard	67
4.7.6	EUT Operating Condition	67
4.7.7	Test Results	68
5	Pictures of Test Arrangements.....	70
	Annex A- Radiated Out of Band Emission (OOBE) Measurement (For U-NII-3 band)	71
	Appendix – Information of the Testing Laboratories	74

Release Control Record

Issue No.	Description	Date Issued
RF190910E04-1	Original release.	Oct. 17, 2019

1 Certificate of Conformity

Product: Wifi module

Brand: Leonton

Test Model: TLP3-71300-5120-24-T

Sample Status: MASS-PRODUCTION

Applicant: Leonton Technologies Co., Ltd.

Test Date: Sep. 19 to 25, 2019

Standard: 47 CFR FCC Part 15, Subpart E (Section 15.407)
ANSI C63.10: 2013

The above equipment has been tested by **Bureau Veritas Consumer Products Services (H.K.) Ltd., Taoyuan Branch**, and found compliance with the requirement of the above standards. The test record, data evaluation & Equipment Under Test (EUT) configurations represented herein are true and accurate accounts of the measurements of the sample's EMC characteristics under the conditions specified in this report.

Prepared by : Wendy Wu , **Date:** Oct. 17, 2019
Wendy Wu / Specialist

Approved by : Clark Lin , **Date:** Oct. 17, 2019
Clark Lin / Technical Manager

2 Summary of Test Results

47 CFR FCC Part 15, Subpart E (Section 15.407)			
FCC Clause	Test Item	Result	Remarks
15.407(b)(6)	AC Power Conducted Emissions	PASS	Meet the requirement of limit. Minimum passing margin is -4.54dB at 0.54844MHz.
15.407(b) (1/2/3/4(i/ii)/6)	Radiated Emissions & Band Edge Measurement*	PASS	Meet the requirement of limit. Minimum passing margin is -0.2dB at 15540.00MHz, 15720.00MHz.
15.407(a)(1/2/3)	Max Average Transmit Power	PASS	Meet the requirement of limit.
---	Occupied Bandwidth Measurement	-	Reference only.
15.407(a)(1/2/3)	Peak Power Spectral Density	PASS	Meet the requirement of limit.
15.407(e)	6dB bandwidth	PASS	Meet the requirement of limit. (U-NII-3 Band only)
15.407(g)	Frequency Stability	PASS	Meet the requirement of limit.
15.203	Antenna Requirement	PASS	Antenna connector is R-SMA not a standard connector.

*For U-NII-3 band compliance with rule part 15.407(b)(4)(i), the OOB test plots were recorded in Annex A.

Note:

Determining compliance based on the results of the compliance measurement, not taking into account measurement instrumentation uncertainty.

2.1 Measurement Uncertainty

Where relevant, the following measurement uncertainty levels have been estimated for tests performed on the EUT as specified in CISPR 16-4-2:

Measurement	Frequency	Expanded Uncertainty (k=2) (±)
Conducted Emissions at mains ports	150kHz ~ 30MHz	1.8 dB
Radiated Emissions up to 1 GHz	9kHz ~ 30MHz	3.0 dB
	30MHz ~ 1GHz	4.9 dB
Radiated Emissions above 1 GHz	1GHz ~ 6GHz	5.1 dB
	6GHz ~ 18GHz	4.9 dB
	18GHz ~ 40GHz	5.2 dB

2.2 Modification Record

There were no modifications required for compliance.

3 General Information

3.1 General Description of EUT

Product	Wifi module
Brand	Leonton
Test Model	TLP3-71300-5120-24-T
Status of EUT	MASS-PRODUCTION
Power Supply Rating	3.3Vdc from host equipment
Modulation Type	CCK, DQPSK, DBPSK for DSSS 64QAM, 16QAM, QPSK, BPSK for OFDM 256QAM for OFDM in 11ac mode only
Modulation Technology	DSSS, OFDM
Transfer Rate	802.11b: up to 11Mbps 802.11a/g: up to 54Mbps 802.11n: up to 150Mbps 802.11ac: up to 433.3Mbps
Operating Frequency	2.4GHz: 2.412 ~ 2.462 GHz 5GHz: 5.18~ 5.24 GHz, 5.745 ~ 5.825 GHz
Number of Channel	2.4GHz: 802.11b, 802.11g, 802.11n (HT20): 11 802.11n (HT40): 7 5GHz: 802.11a, 802.11n (HT20), 802.11ac (VHT20): 9 802.11n (HT40), 802.11ac (VHT40): 4 802.11ac (VHT80): 2
Output Power	2.412 ~ 2.462GHz: 725.429 mW 5.18 ~ 5.24GHz: 101.224 mW 5.745 ~ 5.825GHz: 121.016 mW
Antenna Type	Refer to Note
Antenna Connector	Refer to Note
Accessory Device	NA
Data Cable Supplied	NA

Note:

- 2.4GHz & 5GHz technology can't transmit at same time.
- The antennas provided to the EUT, please refer to the following table:

Ant. No.	Chain No.	Antenna Gain (dBi)	Frequency Range (GHz)	Antenna Type	Connector Type
1	Chain 0	3	2.4~2.4835	Dipole	R-SMA
		5	5.15~5.85		
2	Chain 1	3	2.4~2.4835	Dipole	R-SMA
		5	5.15~5.85		

3. The EUT incorporates a MIMO function.

2.4GHz Band		
MODULATION MODE	TX & RX CONFIGURATION	
802.11b	1TX Diversity	1RX Diversity
802.11g	1TX Diversity	1RX Diversity
802.11n (HT20)	2TX	2RX
802.11n (HT40)	2TX	2RX
5GHz Band		
MODULATION MODE	TX & RX CONFIGURATION	
802.11a	1TX Diversity	1RX Diversity
802.11n (HT20)	2TX	2RX
802.11n (HT40)	2TX	2RX
802.11ac VHT20	2TX	2RX
802.11ac VHT40	2TX	2RX
802.11ac VHT80	2TX	2RX

4. The above EUT information is declared by manufacturer and for more detailed features description, please refers to the manufacturer's specifications or user's manual.

3.2 Description of Test Modes

FOR 5180 ~ 5240MHz

4 channels are provided for 802.11a, 802.11n (HT20), 802.11ac (VHT20):

Channel	Frequency	Channel	Frequency
36	5180 MHz	44	5220 MHz
40	5200 MHz	48	5240 MHz

2 channels are provided for 802.11n (HT40), 802.11ac (VHT40):

Channel	Frequency	Channel	Frequency
38	5190 MHz	46	5230 MHz

1 channel is provided for 802.11ac (VHT80):

Channel	Frequency
42	5210 MHz

FOR 5745 ~ 5825MHz:

5 channels are provided for 802.11a, 802.11n (HT20), 802.11ac (VHT20):

Channel	Frequency	Channel	Frequency
149	5745 MHz	161	5805 MHz
153	5765 MHz	165	5825 MHz
157	5785 MHz		

2 channels are provided for 802.11n (HT40), 802.11ac (VHT40):

Channel	Frequency	Channel	Frequency
151	5755 MHz	159	5795 MHz

1 channel is provided for 802.11ac (VHT80):

Channel	Frequency
155	5775 MHz

3.2.1 Test Mode Applicability and Tested Channel Detail

EUT Configure Mode	Applicable To				Description
	RE≥1G	RE<1G	PLC	APCM	
-	√	√	√	√	-

Where **RE≥1G**: Radiated Emission above 1GHz **RE<1G**: Radiated Emission below 1GHz
PLC: Power Line Conducted Emission **APCM**: Antenna Port Conducted Measurement

Radiated Emission Test (Above 1GHz):

- Pre-Scan has been conducted to determine the worst-case mode from all possible combinations between available modulations, data rates and antenna ports (if EUT with antenna diversity architecture).
- Following channel(s) was (were) selected for the final test as listed below.

Mode	FREQ. Band (MHz)	Available Channel	Tested Channel	Modulation Technology	Modulation Type	Data Rate (Mbps)
802.11a	5180-5240	36 to 48	36, 40, 48	OFDM	BPSK	6
802.11ac (VHT20)		36 to 48	36, 40, 48	OFDM	BPSK	6.5
802.11ac (VHT40)		38 to 46	38, 46	OFDM	BPSK	13.5
802.11ac (VHT80)		42	42	OFDM	BPSK	29.3
802.11a	5745-5825	149 to 165	149, 157, 165	OFDM	BPSK	6
802.11ac (VHT20)		149 to 165	149, 157, 165	OFDM	BPSK	6.5
802.11ac (VHT40)		151 to 159	151, 159	OFDM	BPSK	13.5
802.11ac (VHT80)		155	155	OFDM	BPSK	29.3

Radiated Emission Test (Below 1GHz):

- Pre-Scan has been conducted to determine the worst-case mode from all possible combinations between available modulations, data rates and antenna ports (if EUT with antenna diversity architecture).
- Following channel(s) was (were) selected for the final test as listed below.

Mode	FREQ. Band (MHz)	Available Channel	Tested Channel	Modulation Technology	Modulation Type	Data Rate (Mbps)
802.11ac (VHT40)	5180-5240 5745-5825	38 to 46 151 to 159	151	OFDM	BPSK	13.5

Power Line Conducted Emission Test:

- Pre-Scan has been conducted to determine the worst-case mode from all possible combinations between available modulations, data rates and antenna ports (if EUT with antenna diversity architecture).
- Following channel(s) was (were) selected for the final test as listed below.

Mode	FREQ. Band (MHz)	Available Channel	Tested Channel	Modulation Technology	Modulation Type	Data Rate (Mbps)
802.11ac (VHT40)	5180-5240 5745-5825	38 to 46 151 to 159	151	OFDM	BPSK	13.5

Antenna Port Conducted Measurement:

- This item includes all test value of each mode, but only includes spectrum plot of worst value of each mode.
- Pre-Scan has been conducted to determine the worst-case mode from all possible combinations between available modulations, data rates and antenna ports (if EUT with antenna diversity architecture).
- Following channel(s) was (were) selected for the final test as listed below.

Mode	FREQ. Band (MHz)	Available Channel	Tested Channel	Modulation Technology	Modulation Type	Data Rate (Mbps)
802.11a	5180-5240	36 to 48	36, 40, 48	OFDM	BPSK	6
802.11ac (VHT20)		36 to 48	36, 40, 48	OFDM	BPSK	6.5
802.11ac (VHT40)		38 to 46	38, 46	OFDM	BPSK	13.5
802.11ac (VHT80)		42	42	OFDM	BPSK	29.3
802.11a	5745-5825	149 to 165	149, 157, 165	OFDM	BPSK	6
802.11ac (VHT20)		149 to 165	149, 157, 165	OFDM	BPSK	6.5
802.11ac (VHT40)		151 to 159	151, 159	OFDM	BPSK	13.5
802.11ac (VHT80)		155	155	OFDM	BPSK	29.3

Test Condition:

Applicable To	Environmental Conditions	Input Power (System)	Tested By
RE \geq 1G	22deg. C, 72%RH	120Vac, 60Hz	Jeff Lee
RE<1G	22deg. C, 71%RH	120Vac, 60Hz	Jeff Lee
PLC	23deg. C, 76%RH	120Vac, 60Hz	Andy Ho
APCM	25deg. C, 60%RH	120Vac, 60Hz	Anderson Chen

3.3 Duty Cycle of Test Signal

Duty cycle of test signal is < 98 %, duty factor shall be considered.

802.11a: Duty cycle = 1.439/1.534 = 0.938, Duty factor = $10 \cdot \log(1/\text{Duty cycle}) = 0.28$

802.11ac (VHT20): Duty cycle = 1.36/1.434 = 0.948, Duty factor = $10 \cdot \log(1/\text{Duty cycle}) = 0.23$

802.11ac (VHT40): Duty cycle = 0.673/0.754 = 0.893, Duty factor = $10 \cdot \log(1/\text{Duty cycle}) = 0.49$

802.11ac (VHT80): Duty cycle = 0.335/0.436 = 0.768, Duty factor = $10 \cdot \log(1/\text{Duty cycle}) = 1.14$

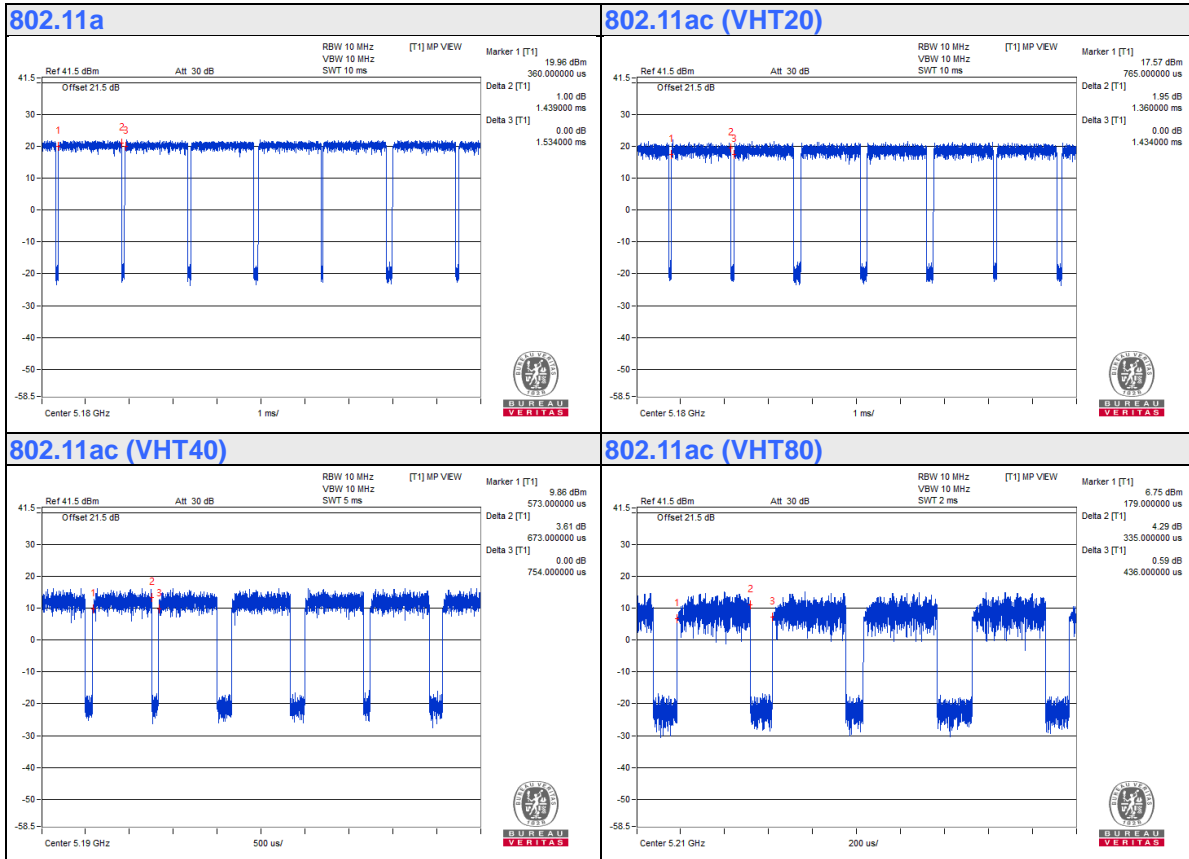

3.4 Description of Support Units

The EUT has been tested as an independent unit together with other necessary accessories or support units. The following support units or accessories were used to form a representative test configuration during the tests.

ID	Product	Brand	Model No.	Serial No.	FCC ID	Remarks
A.	Test Tool	Leonton Technologies Co., Ltd.	NA	NA	NA	Supplied by client
B.	Adapter	Powertron Electronics	PA1024-120IB200	NA	NA	Supplied by client

ID	Descriptions	Qty.	Length (m)	Shielding (Yes/No)	Cores (Qty.)	Remarks
1.	AC Cable	1	1.5	No	0	Supplied by client

3.4.1 Configuration of System under Test

For Conduction emission test:

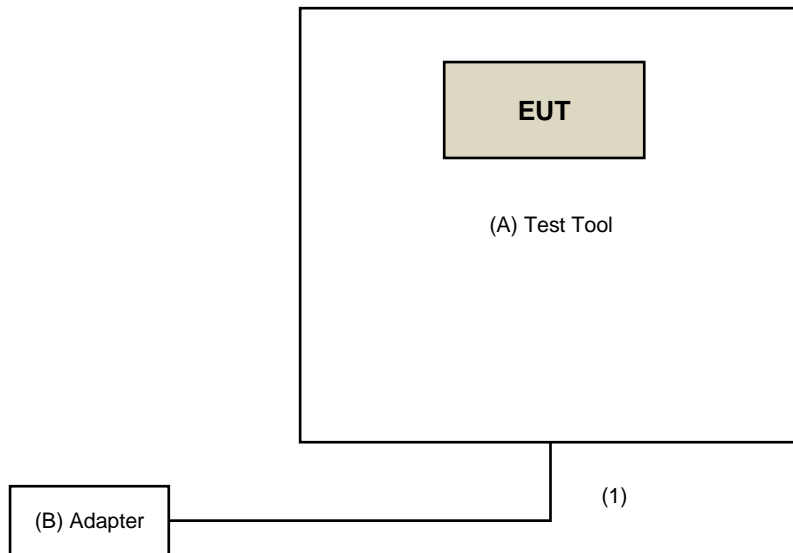

For other test:

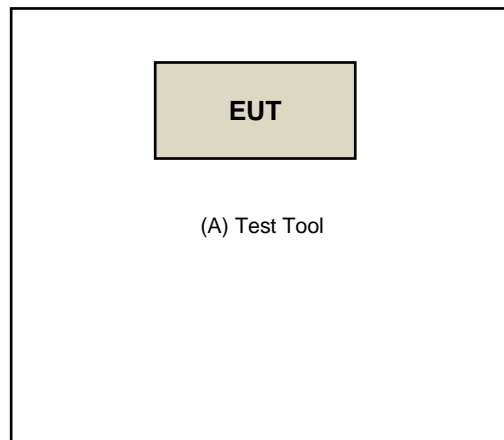

(1)



Under Table

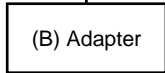

3.5 General Description of Applied Standard

The EUT is a RF Product. According to the specifications of the manufacturer, it must comply with the requirements of the following standards:

FCC Part 15, Subpart E (15.407)
KDB 789033 D02 General UNII Test Procedure New Rules v02r01
KDB 662911 D01 Multiple Transmitter Output v02r01
ANSI C63.10-2013

All test items have been performed and recorded as per the above standards.

4 Test Types and Results

4.1 Radiated Emission and Bandedge Measurement

4.1.1 Limits of Radiated Emission and Bandedge Measurement

Radiated emissions which fall in the restricted bands must comply with the radiated emission limits specified as below table.

Frequencies (MHz)	Field Strength (microvolts/meter)	Measurement Distance (meters)
0.009 ~ 0.490	2400/F(kHz)	300
0.490 ~ 1.705	24000/F(kHz)	30
1.705 ~ 30.0	30	30
30 ~ 88	100	3
88 ~ 216	150	3
216 ~ 960	200	3
Above 960	500	3

NOTE:

1. The lower limit shall apply at the transition frequencies.
2. Emission level (dBuV/m) = 20 log Emission level (uV/m).
3. For frequencies above 1000MHz, the field strength limits are based on average detector, however, the peak field strength of any emission shall not exceed the maximum permitted average limits, specified above by more than 20dB under any condition of modulation.

Limits of unwanted emission out of the restricted bands

Applicable To		Limit	
789033 D02 General UNII Test Procedure New Rules v02r01		Field Strength at 3m	
		PK:74 (dBµV/m)	AV:54 (dBµV/m)
Frequency Band	Applicable To	EIRP Limit	Equivalent Field Strength at 3m
5150~5250 MHz	15.407(b)(1)	PK:-27 (dBm/MHz)	PK:68.2(dBµV/m)
5250~5350 MHz	15.407(b)(2)		
5470~5725 MHz	15.407(b)(3)		
5725~5850 MHz	<input checked="" type="checkbox"/> 15.407(b)(4)(i)	PK:-27 (dBm/MHz) ^{*1} PK:10 (dBm/MHz) ^{*2} PK:15.6 (dBm/MHz) ^{*3} PK:27 (dBm/MHz) ^{*4}	PK: 68.2(dBµV/m) ^{*1} PK:105.2 (dBµV/m) ^{*2} PK: 110.8(dBµV/m) ^{*3} PK:122.2 (dBµV/m) ^{*4}
	<input type="checkbox"/> 15.407(b)(4)(ii)	Emission limits in section 15.247(d)	
^{*1} beyond 75 MHz or more above of the band edge. ^{*3} below the band edge increasing linearly to a level of 15.6 dBm/MHz at 5 MHz above.		^{*2} below the band edge increasing linearly to 10 dBm/MHz at 25 MHz above. ^{*4} from 5 MHz above or below the band edge increasing linearly to a level of 27 dBm/MHz at the band edge.	

Note:

The following formula is used to convert the equipment isotropic radiated power (eirp) to field strength:

$$E = \frac{1000000\sqrt{30P}}{3} \mu\text{V/m, where P is the eirp (Watts).}$$

4.1.2 Test Instruments

DESCRIPTION & MANUFACTURER	MODEL NO.	SERIAL NO.	CALIBRATED DATE	CALIBRATED UNTIL
Test Receiver ESR7 R&S	ESR7	102026	Apr. 24, 2019	Apr. 23, 2020
Spectrum Analyzer Keysight	N9030B	MY57141948	May 25, 2019	May 24, 2020
Pre-Amplifier EMCI	EMC001340	980142	May 30, 2019	May 29, 2020
Loop Antenna Electro-Metrics	EM-6879	264	Jan. 22, 2019	Jan. 21, 2020
RF Cable	NA	LOOPCAB-001	Jan. 14, 2019	Jan. 13, 2020
RF Cable	NA	LOOPCAB-002	Jan. 14, 2019	Jan. 13, 2020
Pre-Amplifier EMCI	EMC330N	980538	Apr. 30, 2019	Apr. 29, 2020
Trilog Broadband Antenna SCHWARZBECK	VULB9168	9168-0842	Nov. 21, 2018	Nov. 20, 2019
RF Cable	8D	966-5-1	May 03, 2019	May 02, 2020
RF Cable	8D	966-5-2	May 03, 2019	May 02, 2020
RF Cable	8D	966-5-3	May 03, 2019	May 02, 2020
Fixed attenuator Mini-Circuits	UNAT-5+	PAD-ATT5-02	Jan. 28, 2019	Jan. 27, 2020
Horn_Antenna SCHWARZBECK	BBHA 9120D	9120D-1819	Nov. 25, 2018	Nov. 24, 2019
Pre-Amplifier EMCI	EMC12630SE	980509	May 03, 2019	May 02, 2020
RF Cable EMCI	EMC104-SM-SM-1500	180503	May 03, 2019	May 02, 2020
RF Cable EMCI	EMC104-SM-SM-2000	180501	May 03, 2019	May 02, 2020
RF Cable EMCI	EMC104-SM-SM-6000	180505	May 03, 2019	May 02, 2020
Pre-Amplifier EMCI	EMC184045SE	980387	Jan. 28, 2019	Jan. 27, 2020
Horn_Antenna SCHWARZBECK	BBHA 9170	BBHA9170519	Nov. 25, 2018	Nov. 24, 2019
RF Cable	EMC102-KM-KM-1200	160924	Jan. 28, 2019	Jan. 27, 2020
RF Cable	EMC102-KM-KM-1200	160925	Jan. 28, 2019	Jan. 27, 2020
Software	ADT_Radiated_V8.7.08	NA	NA	NA
Boresight Antenna Tower & Turn Table Max-Full	MF-7802BS	MF780208530	NA	NA
DC Power Supply Topward	6603D	795558	NA	NA
Temperature & Humidity Chamber Giant Force	GTH-150-40-SP-AR	MAA0812-008	Jan. 09, 2019	Jan. 08, 2020
True RMS Clamp Meter FLUKE	325	31130711WS	May 21, 2019	May 20, 2020
Spectrum Analyzer R&S	FSV40	100964	June 04, 2019	June 03, 2020
Power meter Anritsu	ML2495A	1014008	May 13, 2019	May 12, 2020
Power sensor Anritsu	MA2411B	0917122	May 13, 2019	May 12, 2020

Note:

1. The calibration interval of the above test instruments is 12 months and the calibrations are traceable to NML/ROC and NIST/USA.
2. The test was performed in 966 Chamber No. 5.
3. Loop antenna was used for all emissions below 30 MHz.
4. Tested Date: Sep. 19 to 23, 2019

4.1.3 Test Procedure

For Radiated emission below 30MHz

- a. The EUT was placed on the top of a rotating table 0.8 meters above the ground at a 3 meter chamber room. The table was rotated 360 degrees to determine the position of the highest radiation.
- b. The EUT was set 3 meters away from the interference-receiving antenna, which was mounted on the top of a variable-height antenna tower.
- c. Parallel, perpendicular, and ground-parallel orientations of the antenna are set to make the measurement.
- d. For each suspected emission, the EUT was arranged to its worst case and the rotatable table was turned from 0 degrees to 360 degrees to find the maximum reading.
- e. The test-receiver system was set to Quasi-Peak Detect Function and Specified Bandwidth with Maximum Hold Mode.

NOTE:

1. The resolution bandwidth and video bandwidth of test receiver/spectrum analyzer is 9kHz at frequency below 30MHz.

For Radiated emission above 30MHz

- a. The EUT was placed on the top of a rotating table 0.8 meters (for 30MHz ~ 1GHz) / 1.5 meters (for above 1GHz) above the ground at 3 meter chamber room for test. The table was rotated 360 degrees to determine the position of the highest radiation.
- b. The EUT was set 3 meters away from the interference-receiving antenna, which was mounted on the top of a variable-height antenna tower.
- c. The height of antenna is varied from one meter to four meters above the ground to determine the maximum value of the field strength. Both horizontal and vertical polarizations of the antenna are set to make the measurement.
- d. For each suspected emission, the EUT was arranged to its worst case and then the antenna was tuned to heights from 1 meter to 4 meters and the rotatable table was turned from 0 degrees to 360 degrees to find the maximum reading.
- e. The test-receiver system was set to quasi-peak detect function and specified bandwidth with maximum hold mode when the test frequency is below 1 GHz.
- f. The test-receiver system was set to peak and average detects function and specified bandwidth with maximum hold mode when the test frequency is above 1 GHz. If the peak reading value also meets average limit, measurement with the average detector is unnecessary.

Note:

1. The resolution bandwidth and video bandwidth of test receiver/spectrum analyzer is 120kHz for Quasi-peak detection (QP) at frequency below 1GHz.
2. The resolution bandwidth of test receiver/spectrum analyzer is 1 MHz and the video bandwidth is 3 MHz for Peak detection (PK) at frequency above 1GHz.
3. The resolution bandwidth of test receiver/spectrum analyzer is 1MHz and the video bandwidth is $\geq 1/T$ (Duty cycle < 98%) or 10Hz (Duty cycle $\geq 98\%$) for Average detection (AV) at frequency above 1GHz.
4. All modes of operation were investigated and the worst-case emissions are reported.

4.1.4 Deviation from Test Standard

No deviation.

4.1.5 Test Setup

For Radiated emission below 30MHz

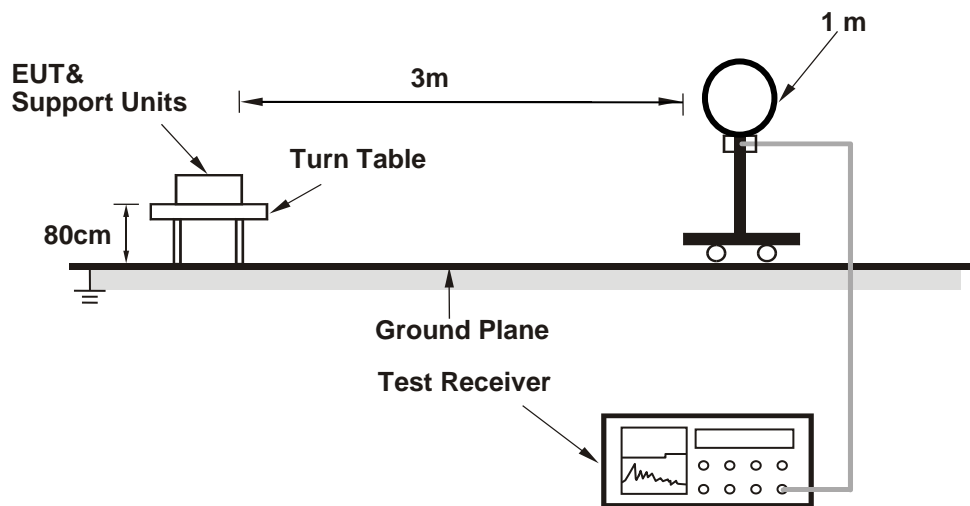

For Radiated emission 30MHz to 1GHz

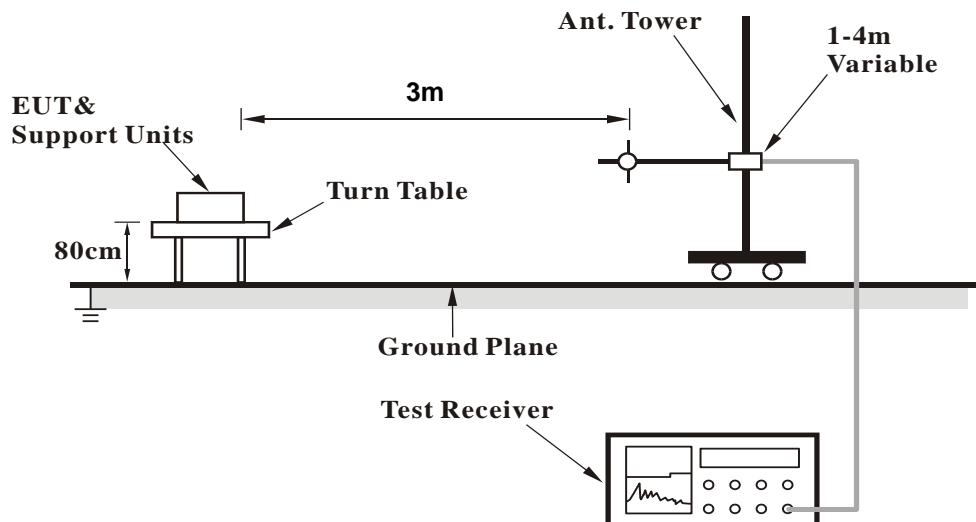

For Radiated emission above 1GHz

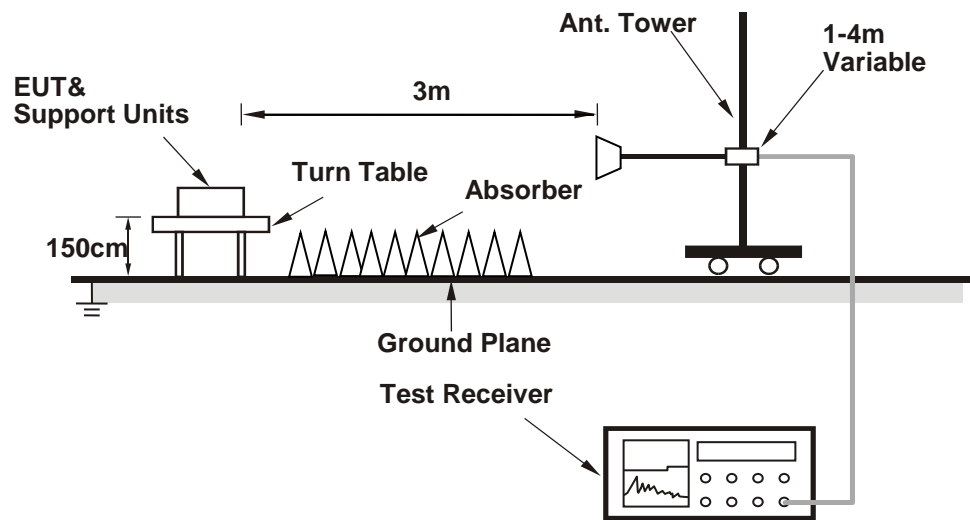

For the actual test configuration, please refer to the attached file (Test Setup Photo).

4.1.6 EUT Operating Condition

- a. Placed the EUT on the testing table.
- b. Controlling software (MT7612E_AP_QA_Tool_V1.0.3.4) has been activated to set the EUT under transmission condition continuously at specific channel frequency.

4.1.7 Test Results

Above 1GHz Data:

802.11a

CHANNEL	TX Channel 36	DETECTOR FUNCTION	Peak (PK)
FREQUENCY RANGE	1GHz ~ 40GHz		Average (AV)

ANTENNA POLARITY & TEST DISTANCE: HORIZONTAL AT 3 M

NO.	FREQ. (MHz)	EMISSION LEVEL (dBuV/m)	LIMIT (dBuV/m)	MARGIN (dB)	ANTENNA HEIGHT (m)	TABLE ANGLE (Degree)	RAW VALUE (dBuV)	CORRECTION FACTOR (dB/m)
1	5150.00	52.1 PK	74.0	-21.9	1.83 H	97	50.0	2.1
2	5150.00	39.5 AV	54.0	-14.5	1.83 H	97	37.4	2.1
3	*5180.00	93.6 PK			1.83 H	97	91.8	1.8
4	*5180.00	84.9 AV			1.83 H	97	83.1	1.8
5	#10360.00	55.0 PK	68.2	-13.2	3.66 H	189	42.9	12.1
6	15540.00	51.8 PK	74.0	-22.2	2.13 H	295	39.6	12.2
7	15540.00	40.0 AV	54.0	-14.0	2.13 H	295	27.8	12.2

ANTENNA POLARITY & TEST DISTANCE: VERTICAL AT 3 M

NO.	FREQ. (MHz)	EMISSION LEVEL (dBuV/m)	LIMIT (dBuV/m)	MARGIN (dB)	ANTENNA HEIGHT (m)	TABLE ANGLE (Degree)	RAW VALUE (dBuV)	CORRECTION FACTOR (dB/m)
1	5150.00	65.6 PK	74.0	-8.4	1.48 V	356	63.5	2.1
2	5150.00	50.8 AV	54.0	-3.2	1.48 V	356	48.7	2.1
3	*5180.00	110.5 PK			1.48 V	356	108.7	1.8
4	*5180.00	101.8 AV			1.48 V	356	100.0	1.8
5	#10360.00	61.5 PK	68.2	-6.7	3.14 V	174	49.4	12.1
6	15540.00	61.0 PK	74.0	-13.0	2.15 V	294	48.8	12.2
7	15540.00	48.9 AV	54.0	-5.1	2.15 V	294	36.7	12.2

REMARKS:

1. Emission Level(dBuV/m) = Raw Value(dBuV) + Correction Factor(dB/m)
2. Correction Factor(dB/m) = Antenna Factor(dB/m) + Cable Factor(dB) – Pre-Amplifier Factor(dB)
3. Margin value = Emission Level – Limit value
4. The other emission levels were very low against the limit.
5. " * ": Fundamental frequency.
6. " # ": The radiated frequency is out of the restricted band.

CHANNEL	TX Channel 40	DETECTOR FUNCTION	Peak (PK)
FREQUENCY RANGE	1GHz ~ 40GHz		Average (AV)

ANTENNA POLARITY & TEST DISTANCE: HORIZONTAL AT 3 M

NO.	FREQ. (MHz)	EMISSION LEVEL (dBuV/m)	LIMIT (dBuV/m)	MARGIN (dB)	ANTENNA HEIGHT (m)	TABLE ANGLE (Degree)	RAW VALUE (dBuV)	CORRECTION FACTOR (dB/m)
1	*5200.00	94.9 PK			2.70 H	322	93.2	1.7
2	*5200.00	86.3 AV			2.70 H	322	84.6	1.7
3	#10400.00	52.2 PK	68.2	-16.0	2.23 H	147	39.8	12.4
4	15600.00	51.0 PK	74.0	-23.0	3.11 H	138	39.0	12.0
5	15600.00	40.0 AV	54.0	-14.0	3.11 H	138	28.0	12.0

ANTENNA POLARITY & TEST DISTANCE: VERTICAL AT 3 M

NO.	FREQ. (MHz)	EMISSION LEVEL (dBuV/m)	LIMIT (dBuV/m)	MARGIN (dB)	ANTENNA HEIGHT (m)	TABLE ANGLE (Degree)	RAW VALUE (dBuV)	CORRECTION FACTOR (dB/m)
1	*5200.00	111.5 PK			1.50 V	12	109.8	1.7
2	*5200.00	102.4 AV			1.50 V	12	100.7	1.7
3	#10400.00	61.3 PK	68.2	-6.9	3.07 V	176	48.9	12.4
4	15600.00	60.9 PK	74.0	-13.1	2.19 V	286	48.9	12.0
5	15600.00	48.9 AV	54.0	-5.1	2.19 V	286	36.9	12.0

REMARKS:

1. Emission Level(dBuV/m) = Raw Value(dBuV) + Correction Factor(dB/m)
2. Correction Factor(dB/m) = Antenna Factor(dB/m) + Cable Factor(dB) – Pre-Amplifier Factor(dB)
3. Margin value = Emission Level – Limit value
4. The other emission levels were very low against the limit.
5. " * ": Fundamental frequency.
6. " # ": The radiated frequency is out of the restricted band.

CHANNEL	TX Channel 48	DETECTOR FUNCTION	Peak (PK)
FREQUENCY RANGE	1GHz ~ 40GHz		Average (AV)

ANTENNA POLARITY & TEST DISTANCE: HORIZONTAL AT 3 M

NO.	FREQ. (MHz)	EMISSION LEVEL (dBuV/m)	LIMIT (dBuV/m)	MARGIN (dB)	ANTENNA HEIGHT (m)	TABLE ANGLE (Degree)	RAW VALUE (dBuV)	CORRECTION FACTOR (dB/m)
1	*5240.00	98.2 PK			1.89 H	326	96.8	1.4
2	*5240.00	88.6 AV			1.89 H	326	87.2	1.4
3	5350.00	44.0 PK	74.0	-30.0	1.89 H	326	42.5	1.5
4	5350.00	34.2 AV	54.0	-19.8	1.89 H	326	32.7	1.5
5	#10480.00	52.6 PK	68.2	-15.6	2.28 H	134	39.8	12.8
6	15720.00	51.6 PK	74.0	-22.4	3.15 H	139	40.0	11.6
7	15720.00	39.7 AV	54.0	-14.3	3.15 H	139	28.1	11.6

ANTENNA POLARITY & TEST DISTANCE: VERTICAL AT 3 M

NO.	FREQ. (MHz)	EMISSION LEVEL (dBuV/m)	LIMIT (dBuV/m)	MARGIN (dB)	ANTENNA HEIGHT (m)	TABLE ANGLE (Degree)	RAW VALUE (dBuV)	CORRECTION FACTOR (dB/m)
1	*5240.00	111.0 PK			1.63 V	360	109.6	1.4
2	*5240.00	102.0 AV			1.63 V	360	100.6	1.4
3	5350.00	48.9 PK	74.0	-25.1	1.63 V	360	47.4	1.5
4	5350.00	37.9 AV	54.0	-16.1	1.63 V	360	36.4	1.5
5	#10480.00	61.1 PK	68.2	-7.1	3.11 V	169	48.3	12.8
6	15720.00	60.6 PK	74.0	-13.4	2.19 V	294	49.0	11.6
7	15720.00	48.5 AV	54.0	-5.5	2.19 V	294	36.9	11.6

REMARKS:

1. Emission Level(dBuV/m) = Raw Value(dBuV) + Correction Factor(dB/m)
2. Correction Factor(dB/m) = Antenna Factor(dB/m) + Cable Factor(dB) – Pre-Amplifier Factor(dB)
3. Margin value = Emission Level – Limit value
4. The other emission levels were very low against the limit.
5. " * ": Fundamental frequency.
6. " # ": The radiated frequency is out of the restricted band.

CHANNEL	TX Channel 149	DETECTOR FUNCTION	Peak (PK)
FREQUENCY RANGE	1GHz ~ 40GHz		Average (AV)

ANTENNA POLARITY & TEST DISTANCE: HORIZONTAL AT 3 M

NO.	FREQ. (MHz)	EMISSION LEVEL (dBuV/m)	LIMIT (dBuV/m)	MARGIN (dB)	ANTENNA HEIGHT (m)	TABLE ANGLE (Degree)	RAW VALUE (dBuV)	CORRECTION FACTOR (dB/m)
1	*5745.00	98.5 PK			1.91 H	314	96.2	2.3
2	*5745.00	89.0 AV			1.91 H	314	86.7	2.3
3	11490.00	58.3 PK	74.0	-15.7	2.29 H	146	44.2	14.1
4	11490.00	38.9 AV	54.0	-15.1	2.29 H	146	24.8	14.1
5	#17235.00	41.3 PK	68.2	-26.9	3.07 H	138	23.6	17.7

ANTENNA POLARITY & TEST DISTANCE: VERTICAL AT 3 M

NO.	FREQ. (MHz)	EMISSION LEVEL (dBuV/m)	LIMIT (dBuV/m)	MARGIN (dB)	ANTENNA HEIGHT (m)	TABLE ANGLE (Degree)	RAW VALUE (dBuV)	CORRECTION FACTOR (dB/m)
1	*5745.00	111.9 PK			1.88 V	64	109.6	2.3
2	*5745.00	102.9 AV			1.88 V	64	100.6	2.3
3	11490.00	56.9 PK	74.0	-17.1	2.46 V	213	42.8	14.1
4	11490.00	47.6 AV	54.0	-6.4	2.46 V	213	33.5	14.1
5	#17235.00	50.8 PK	68.2	-17.4	3.89 V	185	33.1	17.7

REMARKS:

1. Emission Level(dBuV/m) = Raw Value(dBuV) + Correction Factor(dB/m)
2. Correction Factor(dB/m) = Antenna Factor(dB/m) + Cable Factor(dB) – Pre-Amplifier Factor(dB)
3. Margin value = Emission Level – Limit value
4. The other emission levels were very low against the limit.
5. " * ": Fundamental frequency.
6. " # ": The radiated frequency is out of the restricted band.

CHANNEL	TX Channel 157	DETECTOR FUNCTION	Peak (PK)
FREQUENCY RANGE	1GHz ~ 40GHz		Average (AV)

ANTENNA POLARITY & TEST DISTANCE: HORIZONTAL AT 3 M

NO.	FREQ. (MHz)	EMISSION LEVEL (dBuV/m)	LIMIT (dBuV/m)	MARGIN (dB)	ANTENNA HEIGHT (m)	TABLE ANGLE (Degree)	RAW VALUE (dBuV)	CORRECTION FACTOR (dB/m)
1	*5785.00	97.5 PK			1.89 H	313	95.1	2.4
2	*5785.00	88.2 AV			1.89 H	313	85.8	2.4
3	11570.00	58.5 PK	74.0	-15.5	2.18 H	154	44.4	14.1
4	11570.00	38.9 AV	54.0	-15.1	2.18 H	154	24.8	14.1
5	#17355.00	41.4 PK	68.2	-26.8	3.06 H	147	23.1	18.3

ANTENNA POLARITY & TEST DISTANCE: VERTICAL AT 3 M

NO.	FREQ. (MHz)	EMISSION LEVEL (dBuV/m)	LIMIT (dBuV/m)	MARGIN (dB)	ANTENNA HEIGHT (m)	TABLE ANGLE (Degree)	RAW VALUE (dBuV)	CORRECTION FACTOR (dB/m)
1	*5785.00	111.1 PK			1.74 V	114	108.7	2.4
2	*5785.00	102.7 AV			1.74 V	114	100.3	2.4
3	11570.00	57.0 PK	74.0	-17.0	2.42 V	200	42.9	14.1
4	11570.00	47.5 AV	54.0	-6.5	2.42 V	200	33.4	14.1
5	#17355.00	51.3 PK	68.2	-16.9	3.93 V	192	33.0	18.3

REMARKS:

1. Emission Level(dBuV/m) = Raw Value(dBuV) + Correction Factor(dB/m)
2. Correction Factor(dB/m) = Antenna Factor(dB/m) + Cable Factor(dB) – Pre-Amplifier Factor(dB)
3. Margin value = Emission Level – Limit value
4. The other emission levels were very low against the limit.
5. " * ": Fundamental frequency.
6. " # ": The radiated frequency is out of the restricted band.

CHANNEL	TX Channel 165	DETECTOR FUNCTION	Peak (PK)
FREQUENCY RANGE	1GHz ~ 40GHz		Average (AV)

ANTENNA POLARITY & TEST DISTANCE: HORIZONTAL AT 3 M

NO.	FREQ. (MHz)	EMISSION LEVEL (dBuV/m)	LIMIT (dBuV/m)	MARGIN (dB)	ANTENNA HEIGHT (m)	TABLE ANGLE (Degree)	RAW VALUE (dBuV)	CORRECTION FACTOR (dB/m)
1	*5825.00	96.2 PK			1.84 H	313	93.7	2.5
2	*5825.00	87.0 AV			1.84 H	313	84.5	2.5
3	11650.00	58.7 PK	74.0	-15.3	2.24 H	131	44.8	13.9
4	11650.00	39.2 AV	54.0	-14.8	2.24 H	131	25.3	13.9
5	#17475.00	41.7 PK	68.2	-26.5	3.16 H	149	22.2	19.5

ANTENNA POLARITY & TEST DISTANCE: VERTICAL AT 3 M

NO.	FREQ. (MHz)	EMISSION LEVEL (dBuV/m)	LIMIT (dBuV/m)	MARGIN (dB)	ANTENNA HEIGHT (m)	TABLE ANGLE (Degree)	RAW VALUE (dBuV)	CORRECTION FACTOR (dB/m)
1	*5825.00	111.6 PK			1.87 V	111	109.1	2.5
2	*5825.00	102.1 AV			1.87 V	111	99.6	2.5
3	11650.00	56.5 PK	74.0	-17.5	2.46 V	204	42.6	13.9
4	11650.00	47.2 AV	54.0	-6.8	2.46 V	204	33.3	13.9
5	#17475.00	51.0 PK	68.2	-17.2	3.93 V	191	31.5	19.5

REMARKS:

1. Emission Level(dBuV/m) = Raw Value(dBuV) + Correction Factor(dB/m)
2. Correction Factor(dB/m) = Antenna Factor(dB/m) + Cable Factor(dB) – Pre-Amplifier Factor(dB)
3. Margin value = Emission Level – Limit value
4. The other emission levels were very low against the limit.
5. " * ": Fundamental frequency.
6. " # ": The radiated frequency is out of the restricted band.

802.11ac (VHT20)

CHANNEL	TX Channel 36	DETECTOR FUNCTION	Peak (PK)
FREQUENCY RANGE	1GHz ~ 40GHz		Average (AV)

ANTENNA POLARITY & TEST DISTANCE: HORIZONTAL AT 3 M								
NO.	FREQ. (MHz)	EMISSION LEVEL (dBuV/m)	LIMIT (dBuV/m)	MARGIN (dB)	ANTENNA HEIGHT (m)	TABLE ANGLE (Degree)	RAW VALUE (dBuV)	CORRECTION FACTOR (dB/m)
1	4691.00	47.4 PK	74.0	-26.6	1.50 H	33	46.2	1.2
2	4691.00	36.8 AV	54.0	-17.2	1.50 H	33	35.6	1.2
3	4708.00	46.9 PK	74.0	-27.1	1.50 H	33	45.7	1.2
4	4708.00	36.7 AV	54.0	-17.3	1.50 H	33	35.5	1.2
5	5150.00	47.6 PK	74.0	-26.4	1.50 H	33	45.5	2.1
6	5150.00	37.2 AV	54.0	-16.8	1.50 H	33	35.1	2.1
7	*5180.00	91.6 PK			1.50 H	33	89.8	1.8
8	*5180.00	83.2 AV			1.50 H	33	81.4	1.8
9	#10360.00	42.8 PK	68.2	-25.4	3.67 H	158	30.7	12.1
10	15540.00	46.0 PK	74.0	-28.0	1.99 H	165	33.8	12.2
11	15540.00	33.4 AV	54.0	-20.6	1.99 H	165	21.2	12.2

ANTENNA POLARITY & TEST DISTANCE: VERTICAL AT 3 M								
NO.	FREQ. (MHz)	EMISSION LEVEL (dBuV/m)	LIMIT (dBuV/m)	MARGIN (dB)	ANTENNA HEIGHT (m)	TABLE ANGLE (Degree)	RAW VALUE (dBuV)	CORRECTION FACTOR (dB/m)
1	4691.00	51.2 PK	74.0	-22.8	1.57 V	92	50.0	1.2
2	4691.00	40.1 AV	54.0	-13.9	1.57 V	92	38.9	1.2
3	4708.00	50.1 PK	74.0	-23.9	1.57 V	92	48.9	1.2
4	4708.00	39.9 AV	54.0	-14.1	1.57 V	92	38.7	1.2
5	5150.00	66.0 PK	74.0	-8.0	1.57 V	92	63.9	2.1
6	5150.00	51.5 AV	54.0	-2.5	1.57 V	92	49.4	2.1
7	*5180.00	112.7 PK			1.57 V	92	110.9	1.8
8	*5180.00	105.6 AV			1.57 V	92	103.8	1.8
9	#10360.00	49.0 PK	68.2	-19.2	1.80 V	117	36.9	12.1
10	15540.00	67.1 PK	74.0	-6.9	3.85 V	174	54.9	12.2
11	15540.00	53.8 AV	54.0	-0.2	3.85 V	174	41.6	12.2

REMARKS:

1. Emission Level(dBuV/m) = Raw Value(dBuV) + Correction Factor(dB/m)
2. Correction Factor(dB/m) = Antenna Factor(dB/m) + Cable Factor(dB) – Pre-Amplifier Factor(dB)
3. Margin value = Emission Level – Limit value
4. The other emission levels were very low against the limit.
5. " * ": Fundamental frequency.
6. " # ": The radiated frequency is out of the restricted band.

CHANNEL	TX Channel 40	DETECTOR FUNCTION	Peak (PK)
FREQUENCY RANGE	1GHz ~ 40GHz		Average (AV)

ANTENNA POLARITY & TEST DISTANCE: HORIZONTAL AT 3 M

NO.	FREQ. (MHz)	EMISSION LEVEL (dBuV/m)	LIMIT (dBuV/m)	MARGIN (dB)	ANTENNA HEIGHT (m)	TABLE ANGLE (Degree)	RAW VALUE (dBuV)	CORRECTION FACTOR (dB/m)
1	*5200.00	99.2 PK			1.94 H	301	97.5	1.7
2	*5200.00	89.7 AV			1.94 H	301	88.0	1.7
3	#10400.00	43.5 PK	68.2	-24.7	3.64 H	150	31.1	12.4
4	15600.00	45.3 PK	74.0	-28.7	1.96 H	169	33.3	12.0
5	15600.00	33.6 AV	54.0	-20.4	1.96 H	169	21.6	12.0

ANTENNA POLARITY & TEST DISTANCE: VERTICAL AT 3 M

NO.	FREQ. (MHz)	EMISSION LEVEL (dBuV/m)	LIMIT (dBuV/m)	MARGIN (dB)	ANTENNA HEIGHT (m)	TABLE ANGLE (Degree)	RAW VALUE (dBuV)	CORRECTION FACTOR (dB/m)
1	*5200.00	116.5 PK			1.76 V	90	114.8	1.7
2	*5200.00	107.3 AV			1.76 V	90	105.6	1.7
3	#10400.00	48.6 PK	68.2	-19.6	1.85 V	114	36.2	12.4
4	15600.00	65.7 PK	74.0	-8.3	3.85 V	174	53.7	12.0
5	15600.00	53.5 AV	54.0	-0.5	3.85 V	174	41.5	12.0

REMARKS:

1. Emission Level(dBuV/m) = Raw Value(dBuV) + Correction Factor(dB/m)
2. Correction Factor(dB/m) = Antenna Factor(dB/m) + Cable Factor(dB) – Pre-Amplifier Factor(dB)
3. Margin value = Emission Level – Limit value
4. The other emission levels were very low against the limit.
5. " * ": Fundamental frequency.
6. " # ": The radiated frequency is out of the restricted band.

CHANNEL	TX Channel 48	DETECTOR FUNCTION	Peak (PK)
FREQUENCY RANGE	1GHz ~ 40GHz		Average (AV)

ANTENNA POLARITY & TEST DISTANCE: HORIZONTAL AT 3 M

NO.	FREQ. (MHz)	EMISSION LEVEL (dBuV/m)	LIMIT (dBuV/m)	MARGIN (dB)	ANTENNA HEIGHT (m)	TABLE ANGLE (Degree)	RAW VALUE (dBuV)	CORRECTION FACTOR (dB/m)
1	*5240.00	116.3 PK			1.93 H	301	114.9	1.4
2	*5240.00	107.3 AV			1.93 H	301	105.9	1.4
3	5350.00	44.8 PK	74.0	-29.2	1.93 H	301	43.3	1.5
4	5350.00	34.3 AV	54.0	-19.7	1.93 H	301	32.8	1.5
5	#10480.00	43.0 PK	68.2	-25.2	2.25 H	161	30.2	12.8
6	15720.00	45.6 PK	74.0	-28.4	3.07 H	124	34.0	11.6
7	15720.00	33.2 AV	54.0	-20.8	3.07 H	124	21.6	11.6

ANTENNA POLARITY & TEST DISTANCE: VERTICAL AT 3 M

NO.	FREQ. (MHz)	EMISSION LEVEL (dBuV/m)	LIMIT (dBuV/m)	MARGIN (dB)	ANTENNA HEIGHT (m)	TABLE ANGLE (Degree)	RAW VALUE (dBuV)	CORRECTION FACTOR (dB/m)
1	*5240.00	116.3 PK			1.70 V	80	114.9	1.4
2	*5240.00	107.3 AV			1.70 V	80	105.9	1.4
3	5350.00	51.8 PK	74.0	-22.2	1.70 V	80	50.3	1.5
4	5350.00	41.0 AV	54.0	-13.0	1.70 V	80	39.5	1.5
5	#10480.00	48.3 PK	68.2	-19.9	1.90 V	119	35.5	12.8
6	15720.00	65.9 PK	74.0	-8.1	3.98 V	188	54.3	11.6
7	15720.00	53.8 AV	54.0	-0.2	3.98 V	188	42.2	11.6

REMARKS:

- Emission Level(dBuV/m) = Raw Value(dBuV) + Correction Factor(dB/m)
- Correction Factor(dB/m) = Antenna Factor(dB/m) + Cable Factor(dB) – Pre-Amplifier Factor(dB)
- Margin value = Emission Level – Limit value
- The other emission levels were very low against the limit.
- " * ": Fundamental frequency.
- " # ": The radiated frequency is out of the restricted band.

CHANNEL	TX Channel 149	DETECTOR FUNCTION	Peak (PK)
FREQUENCY RANGE	1GHz ~ 40GHz		Average (AV)

ANTENNA POLARITY & TEST DISTANCE: HORIZONTAL AT 3 M

NO.	FREQ. (MHz)	EMISSION LEVEL (dBuV/m)	LIMIT (dBuV/m)	MARGIN (dB)	ANTENNA HEIGHT (m)	TABLE ANGLE (Degree)	RAW VALUE (dBuV)	CORRECTION FACTOR (dB/m)
1	*5745.00	98.0 PK			1.90 H	313	95.7	2.3
2	*5745.00	88.7 AV			1.90 H	313	86.4	2.3
3	11490.00	40.5 PK	74.0	-33.5	2.25 H	150	26.4	14.1
4	11490.00	32.9 AV	54.0	-21.1	2.25 H	150	18.8	14.1
5	#17235.00	45.3 PK	68.2	-22.9	3.08 H	131	27.6	17.7

ANTENNA POLARITY & TEST DISTANCE: VERTICAL AT 3 M

NO.	FREQ. (MHz)	EMISSION LEVEL (dBuV/m)	LIMIT (dBuV/m)	MARGIN (dB)	ANTENNA HEIGHT (m)	TABLE ANGLE (Degree)	RAW VALUE (dBuV)	CORRECTION FACTOR (dB/m)
1	*5745.00	115.4 PK			1.88 V	113	113.1	2.3
2	*5745.00	105.9 AV			1.88 V	113	103.6	2.3
3	11490.00	40.0 PK	74.0	-34.0	1.96 V	118	25.9	14.1
4	11490.00	32.5 AV	54.0	-21.5	1.96 V	118	18.4	14.1
5	#17235.00	52.2 PK	68.2	-16.0	3.76 V	295	34.5	17.7

REMARKS:

1. Emission Level(dBuV/m) = Raw Value(dBuV) + Correction Factor(dB/m)
2. Correction Factor(dB/m) = Antenna Factor(dB/m) + Cable Factor(dB) – Pre-Amplifier Factor(dB)
3. Margin value = Emission Level – Limit value
4. The other emission levels were very low against the limit.
5. " * ": Fundamental frequency.
6. " # ": The radiated frequency is out of the restricted band.

CHANNEL	TX Channel 157	DETECTOR FUNCTION	Peak (PK)
FREQUENCY RANGE	1GHz ~ 40GHz		Average (AV)

ANTENNA POLARITY & TEST DISTANCE: HORIZONTAL AT 3 M

NO.	FREQ. (MHz)	EMISSION LEVEL (dBuV/m)	LIMIT (dBuV/m)	MARGIN (dB)	ANTENNA HEIGHT (m)	TABLE ANGLE (Degree)	RAW VALUE (dBuV)	CORRECTION FACTOR (dB/m)
1	*5785.00	98.0 PK			1.71 H	314	95.6	2.4
2	*5785.00	88.5 AV			1.71 H	314	86.1	2.4
3	11570.00	41.1 PK	74.0	-32.9	3.68 H	142	27.0	14.1
4	11570.00	33.2 AV	54.0	-20.8	3.68 H	142	19.1	14.1
5	#17355.00	46.0 PK	68.2	-22.2	1.99 H	150	27.7	18.3

ANTENNA POLARITY & TEST DISTANCE: VERTICAL AT 3 M

NO.	FREQ. (MHz)	EMISSION LEVEL (dBuV/m)	LIMIT (dBuV/m)	MARGIN (dB)	ANTENNA HEIGHT (m)	TABLE ANGLE (Degree)	RAW VALUE (dBuV)	CORRECTION FACTOR (dB/m)
1	*5785.00	115.3 PK			1.88 V	113	112.9	2.4
2	*5785.00	106.2 AV			1.88 V	113	103.8	2.4
3	11570.00	40.5 PK	74.0	-33.5	1.94 V	106	26.4	14.1
4	11570.00	32.8 AV	54.0	-21.2	1.94 V	106	18.7	14.1
5	#17355.00	52.1 PK	68.2	-16.1	1.96 V	192	33.8	18.3

REMARKS:

1. Emission Level(dBuV/m) = Raw Value(dBuV) + Correction Factor(dB/m)
2. Correction Factor(dB/m) = Antenna Factor(dB/m) + Cable Factor(dB) – Pre-Amplifier Factor(dB)
3. Margin value = Emission Level – Limit value
4. The other emission levels were very low against the limit.
5. " * ": Fundamental frequency.
6. " # ": The radiated frequency is out of the restricted band.

CHANNEL	TX Channel 165	DETECTOR FUNCTION	Peak (PK)
FREQUENCY RANGE	1GHz ~ 40GHz		Average (AV)

ANTENNA POLARITY & TEST DISTANCE: HORIZONTAL AT 3 M

NO.	FREQ. (MHz)	EMISSION LEVEL (dBuV/m)	LIMIT (dBuV/m)	MARGIN (dB)	ANTENNA HEIGHT (m)	TABLE ANGLE (Degree)	RAW VALUE (dBuV)	CORRECTION FACTOR (dB/m)
1	*5825.00	96.3 PK			2.01 H	313	93.8	2.5
2	*5825.00	87.0 AV			2.01 H	313	84.5	2.5
3	11650.00	40.6 PK	74.0	-33.4	3.70 H	143	26.7	13.9
4	11650.00	32.8 AV	54.0	-21.2	3.70 H	143	18.9	13.9
5	#17475.00	46.1 PK	68.2	-22.1	1.93 H	159	26.6	19.5

ANTENNA POLARITY & TEST DISTANCE: VERTICAL AT 3 M

NO.	FREQ. (MHz)	EMISSION LEVEL (dBuV/m)	LIMIT (dBuV/m)	MARGIN (dB)	ANTENNA HEIGHT (m)	TABLE ANGLE (Degree)	RAW VALUE (dBuV)	CORRECTION FACTOR (dB/m)
1	*5825.00	114.6 PK			1.88 V	117	112.1	2.5
2	*5825.00	105.6 AV			1.88 V	117	103.1	2.5
3	11650.00	40.5 PK	74.0	-33.5	1.92 V	130	26.6	13.9
4	11650.00	33.0 AV	54.0	-21.0	1.92 V	130	19.1	13.9
5	#17475.00	52.1 PK	68.2	-16.1	1.83 V	37	32.6	19.5

REMARKS:

1. Emission Level(dBuV/m) = Raw Value(dBuV) + Correction Factor(dB/m)
2. Correction Factor(dB/m) = Antenna Factor(dB/m) + Cable Factor(dB) – Pre-Amplifier Factor(dB)
3. Margin value = Emission Level – Limit value
4. The other emission levels were very low against the limit.
5. " * ": Fundamental frequency.
6. " # ": The radiated frequency is out of the restricted band.

802.11ac (VHT40)

CHANNEL	TX Channel 38	DETECTOR FUNCTION	Peak (PK)
FREQUENCY RANGE	1GHz ~ 40GHz		Average (AV)

ANTENNA POLARITY & TEST DISTANCE: HORIZONTAL AT 3 M								
NO.	FREQ. (MHz)	EMISSION LEVEL (dBuV/m)	LIMIT (dBuV/m)	MARGIN (dB)	ANTENNA HEIGHT (m)	TABLE ANGLE (Degree)	RAW VALUE (dBuV)	CORRECTION FACTOR (dB/m)
1	5150.00	49.1 PK	74.0	-24.9	2.10 H	296	47.0	2.1
2	5150.00	43.0 AV	54.0	-11.0	2.10 H	296	40.9	2.1
3	*5190.00	92.5 PK			2.10 H	296	90.7	1.8
4	*5190.00	82.2 AV			2.10 H	296	80.4	1.8
5	#10380.00	40.3 PK	68.2	-27.9	3.72 H	151	28.0	12.3
6	15570.00	44.0 PK	74.0	-30.0	2.05 H	168	31.8	12.2
7	15570.00	31.6 AV	54.0	-22.4	2.05 H	168	19.4	12.2

ANTENNA POLARITY & TEST DISTANCE: VERTICAL AT 3 M								
NO.	FREQ. (MHz)	EMISSION LEVEL (dBuV/m)	LIMIT (dBuV/m)	MARGIN (dB)	ANTENNA HEIGHT (m)	TABLE ANGLE (Degree)	RAW VALUE (dBuV)	CORRECTION FACTOR (dB/m)
1	5150.00	59.7 PK	74.0	-14.3	1.77 V	91	57.6	2.1
2	5150.00	53.5 AV	54.0	-0.5	1.77 V	91	51.4	2.1
3	*5190.00	108.7 PK			1.77 V	91	106.9	1.8
4	*5190.00	99.4 AV			1.77 V	91	97.6	1.8
5	#10380.00	41.2 PK	68.2	-27.0	1.89 V	115	28.9	12.3
6	15570.00	44.2 PK	74.0	-29.8	1.80 V	29	32.0	12.2
7	15570.00	31.6 AV	54.0	-22.4	1.80 V	29	19.4	12.2

REMARKS:

1. Emission Level(dBuV/m) = Raw Value(dBuV) + Correction Factor(dB/m)
2. Correction Factor(dB/m) = Antenna Factor(dB/m) + Cable Factor(dB) – Pre-Amplifier Factor(dB)
3. Margin value = Emission Level – Limit value
4. The other emission levels were very low against the limit.
5. " * ": Fundamental frequency.
6. " # ": The radiated frequency is out of the restricted band.

CHANNEL	TX Channel 46	DETECTOR FUNCTION	Peak (PK)
FREQUENCY RANGE	1GHz ~ 40GHz		Average (AV)

ANTENNA POLARITY & TEST DISTANCE: HORIZONTAL AT 3 M

NO.	FREQ. (MHz)	EMISSION LEVEL (dBuV/m)	LIMIT (dBuV/m)	MARGIN (dB)	ANTENNA HEIGHT (m)	TABLE ANGLE (Degree)	RAW VALUE (dBuV)	CORRECTION FACTOR (dB/m)
1	*5230.00	97.7 PK			2.12 H	321	96.2	1.5
2	*5230.00	87.6 AV			2.12 H	321	86.1	1.5
3	5350.00	50.1 PK	74.0	-23.9	2.12 H	321	48.6	1.5
4	5350.00	38.8 AV	54.0	-15.2	2.12 H	321	37.3	1.5
5	#10460.00	41.5 PK	68.2	-26.7	3.66 H	163	28.8	12.7
6	15690.00	43.8 PK	74.0	-30.2	2.02 H	159	32.2	11.6
7	15690.00	31.1 AV	54.0	-22.9	2.02 H	159	19.5	11.6

ANTENNA POLARITY & TEST DISTANCE: VERTICAL AT 3 M

NO.	FREQ. (MHz)	EMISSION LEVEL (dBuV/m)	LIMIT (dBuV/m)	MARGIN (dB)	ANTENNA HEIGHT (m)	TABLE ANGLE (Degree)	RAW VALUE (dBuV)	CORRECTION FACTOR (dB/m)
1	*5230.00	113.1 PK			1.89 V	92	111.6	1.5
2	*5230.00	105.3 AV			1.89 V	92	103.8	1.5
3	5350.00	60.0 PK	74.0	-14.0	1.89 V	92	58.5	1.5
4	5350.00	48.8 AV	54.0	-5.2	1.89 V	92	47.3	1.5
5	#10460.00	41.0 PK	68.2	-27.2	1.88 V	107	28.3	12.7
6	15690.00	52.7 PK	74.0	-21.3	1.82 V	34	41.1	11.6
7	15690.00	42.6 AV	54.0	-11.4	1.82 V	34	31.0	11.6

REMARKS:

1. Emission Level(dBuV/m) = Raw Value(dBuV) + Correction Factor(dB/m)
2. Correction Factor(dB/m) = Antenna Factor(dB/m) + Cable Factor(dB) – Pre-Amplifier Factor(dB)
3. Margin value = Emission Level – Limit value
4. The other emission levels were very low against the limit.
5. " * ": Fundamental frequency.
6. " # ": The radiated frequency is out of the restricted band.

CHANNEL	TX Channel 151	DETECTOR FUNCTION	Peak (PK)
FREQUENCY RANGE	1GHz ~ 40GHz		Average (AV)

ANTENNA POLARITY & TEST DISTANCE: HORIZONTAL AT 3 M

NO.	FREQ. (MHz)	EMISSION LEVEL (dBuV/m)	LIMIT (dBuV/m)	MARGIN (dB)	ANTENNA HEIGHT (m)	TABLE ANGLE (Degree)	RAW VALUE (dBuV)	CORRECTION FACTOR (dB/m)
1	*5755.00	95.6 PK			2.14 H	310	93.3	2.3
2	*5755.00	86.4 AV			2.14 H	310	84.1	2.3
3	11510.00	40.2 PK	74.0	-33.8	3.64 H	161	26.1	14.1
4	11510.00	32.7 AV	54.0	-21.3	3.64 H	161	18.6	14.1
5	#17265.00	42.8 PK	68.2	-25.4	2.05 H	151	25.0	17.8

ANTENNA POLARITY & TEST DISTANCE: VERTICAL AT 3 M

NO.	FREQ. (MHz)	EMISSION LEVEL (dBuV/m)	LIMIT (dBuV/m)	MARGIN (dB)	ANTENNA HEIGHT (m)	TABLE ANGLE (Degree)	RAW VALUE (dBuV)	CORRECTION FACTOR (dB/m)
1	*5755.00	112.8 PK			2.25 V	82	110.5	2.3
2	*5755.00	104.5 AV			2.25 V	82	102.2	2.3
3	11510.00	40.2 PK	74.0	-33.8	1.90 V	128	26.1	14.1
4	11510.00	32.6 AV	54.0	-21.4	1.90 V	128	18.5	14.1
5	#17265.00	42.3 PK	68.2	-25.9	1.85 V	41	24.5	17.8

REMARKS:

1. Emission Level(dBuV/m) = Raw Value(dBuV) + Correction Factor(dB/m)
2. Correction Factor(dB/m) = Antenna Factor(dB/m) + Cable Factor(dB) – Pre-Amplifier Factor(dB)
3. Margin value = Emission Level – Limit value
4. The other emission levels were very low against the limit.
5. " * ": Fundamental frequency.
6. " # ": The radiated frequency is out of the restricted band.

CHANNEL	TX Channel 159	DETECTOR FUNCTION	Peak (PK)
FREQUENCY RANGE	1GHz ~ 40GHz		Average (AV)

ANTENNA POLARITY & TEST DISTANCE: HORIZONTAL AT 3 M

NO.	FREQ. (MHz)	EMISSION LEVEL (dBuV/m)	LIMIT (dBuV/m)	MARGIN (dB)	ANTENNA HEIGHT (m)	TABLE ANGLE (Degree)	RAW VALUE (dBuV)	CORRECTION FACTOR (dB/m)
1	*5795.00	97.3 PK			2.17 H	230	94.8	2.5
2	*5795.00	89.2 AV			2.17 H	230	86.7	2.5
3	11590.00	40.2 PK	74.0	-33.8	3.68 H	158	26.1	14.1
4	11590.00	32.9 AV	54.0	-21.1	3.68 H	158	18.8	14.1
5	#17385.00	42.1 PK	68.2	-26.1	1.97 H	167	23.6	18.5

ANTENNA POLARITY & TEST DISTANCE: VERTICAL AT 3 M

NO.	FREQ. (MHz)	EMISSION LEVEL (dBuV/m)	LIMIT (dBuV/m)	MARGIN (dB)	ANTENNA HEIGHT (m)	TABLE ANGLE (Degree)	RAW VALUE (dBuV)	CORRECTION FACTOR (dB/m)
1	*5795.00	112.2 PK			2.26 V	91	109.7	2.5
2	*5795.00	102.7 AV			2.26 V	91	100.2	2.5
3	11590.00	40.3 PK	74.0	-33.7	1.87 V	138	26.2	14.1
4	11590.00	32.8 AV	54.0	-21.2	1.87 V	138	18.7	14.1
5	#17385.00	42.5 PK	68.2	-25.7	1.84 V	49	24.0	18.5

REMARKS:

1. Emission Level(dBuV/m) = Raw Value(dBuV) + Correction Factor(dB/m)
2. Correction Factor(dB/m) = Antenna Factor(dB/m) + Cable Factor(dB) – Pre-Amplifier Factor(dB)
3. Margin value = Emission Level – Limit value
4. The other emission levels were very low against the limit.
5. " * ": Fundamental frequency.
6. " # ": The radiated frequency is out of the restricted band.

802.11ac (VHT80)

CHANNEL	TX Channel 42	DETECTOR FUNCTION	Peak (PK)
FREQUENCY RANGE	1GHz ~ 40GHz		Average (AV)

ANTENNA POLARITY & TEST DISTANCE: HORIZONTAL AT 3 M								
NO.	FREQ. (MHz)	EMISSION LEVEL (dBuV/m)	LIMIT (dBuV/m)	MARGIN (dB)	ANTENNA HEIGHT (m)	TABLE ANGLE (Degree)	RAW VALUE (dBuV)	CORRECTION FACTOR (dB/m)
1	4694.00	41.9 PK	74.0	-32.1	2.12 H	320	40.7	1.2
2	4694.00	31.2 AV	54.0	-22.8	2.12 H	320	30.0	1.2
3	4766.00	42.1 PK	74.0	-31.9	2.12 H	320	40.9	1.2
4	4766.00	31.6 AV	54.0	-22.4	2.12 H	320	30.4	1.2
5	5150.00	52.1 PK	74.0	-21.9	2.12 H	320	50.0	2.1
6	5150.00	43.4 AV	54.0	-10.6	2.12 H	320	41.3	2.1
7	*5210.00	88.3 PK			2.12 H	320	86.7	1.6
8	*5210.00	78.9 AV			2.12 H	320	77.3	1.6
9	5350.00	42.1 PK	74.0	-31.9	2.12 H	320	40.6	1.5
10	5350.00	31.4 AV	54.0	-22.6	2.12 H	320	29.9	1.5
11	#10420.00	40.9 PK	68.2	-27.3	3.68 H	146	28.5	12.4
12	15630.00	53.3 PK	74.0	-20.7	2.00 H	176	41.5	11.8
13	15630.00	42.4 AV	54.0	-11.6	2.00 H	176	30.6	11.8

ANTENNA POLARITY & TEST DISTANCE: VERTICAL AT 3 M								
NO.	FREQ. (MHz)	EMISSION LEVEL (dBuV/m)	LIMIT (dBuV/m)	MARGIN (dB)	ANTENNA HEIGHT (m)	TABLE ANGLE (Degree)	RAW VALUE (dBuV)	CORRECTION FACTOR (dB/m)
1	4694.00	52.4 PK	74.0	-21.6	1.89 V	92	51.2	1.2
2	4694.00	41.5 AV	54.0	-12.5	1.89 V	92	40.3	1.2
3	4766.00	54.6 PK	74.0	-19.4	1.89 V	92	53.4	1.2
4	4766.00	45.0 AV	54.0	-9.0	1.89 V	92	43.8	1.2
5	5150.00	62.4 PK	74.0	-11.6	1.89 V	92	60.3	2.1
6	5150.00	53.5 AV	54.0	-0.5	1.89 V	92	51.4	2.1
7	*5210.00	103.7 PK			1.89 V	92	102.1	1.6
8	*5210.00	94.2 AV			1.89 V	92	92.6	1.6
9	5350.00	50.0 PK	74.0	-24.0	1.89 V	92	48.5	1.5
10	5350.00	40.4 AV	54.0	-13.6	1.89 V	92	38.9	1.5
11	#10420.00	41.5 PK	68.2	-26.7	1.85 V	121	29.1	12.4
12	15630.00	53.1 PK	74.0	-20.9	1.81 V	44	41.3	11.8
13	15630.00	42.2 AV	54.0	-11.8	1.81 V	44	30.4	11.8

REMARKS:

1. Emission Level(dBuV/m) = Raw Value(dBuV) + Correction Factor(dB/m)
2. Correction Factor(dB/m) = Antenna Factor(dB/m) + Cable Factor(dB) – Pre-Amplifier Factor(dB)
3. Margin value = Emission Level – Limit value
4. The other emission levels were very low against the limit.
5. " * ": Fundamental frequency.
6. " # ": The radiated frequency is out of the restricted band.

CHANNEL	TX Channel 155	DETECTOR FUNCTION	Peak (PK)
FREQUENCY RANGE	1GHz ~ 40GHz		Average (AV)

ANTENNA POLARITY & TEST DISTANCE: HORIZONTAL AT 3 M

NO.	FREQ. (MHz)	EMISSION LEVEL (dBuV/m)	LIMIT (dBuV/m)	MARGIN (dB)	ANTENNA HEIGHT (m)	TABLE ANGLE (Degree)	RAW VALUE (dBuV)	CORRECTION FACTOR (dB/m)
1	*5775.00	92.3 PK			2.14 H	307	89.9	2.4
2	*5775.00	82.0 AV			2.14 H	307	79.6	2.4
3	11550.00	40.6 PK	74.0	-33.4	3.68 H	143	26.4	14.2
4	11550.00	33.0 AV	54.0	-21.0	3.68 H	143	18.8	14.2
5	#17325.00	42.3 PK	68.2	-25.9	1.98 H	171	24.2	18.1

ANTENNA POLARITY & TEST DISTANCE: VERTICAL AT 3 M

NO.	FREQ. (MHz)	EMISSION LEVEL (dBuV/m)	LIMIT (dBuV/m)	MARGIN (dB)	ANTENNA HEIGHT (m)	TABLE ANGLE (Degree)	RAW VALUE (dBuV)	CORRECTION FACTOR (dB/m)
1	*5775.00	108.3 PK			1.95 V	91	105.9	2.4
2	*5775.00	98.0 AV			1.95 V	91	95.6	2.4
3	11550.00	39.8 PK	74.0	-34.2	1.95 V	143	25.6	14.2
4	11550.00	32.4 AV	54.0	-21.6	1.95 V	143	18.2	14.2
5	#17325.00	42.3 PK	68.2	-25.9	1.83 V	57	24.2	18.1

REMARKS:

1. Emission Level(dBuV/m) = Raw Value(dBuV) + Correction Factor(dB/m)
2. Correction Factor(dB/m) = Antenna Factor(dB/m) + Cable Factor(dB) – Pre-Amplifier Factor(dB)
3. Margin value = Emission Level – Limit value
4. The other emission levels were very low against the limit.
5. " * ": Fundamental frequency.
6. " # ": The radiated frequency is out of the restricted band.

Below 1GHz Data:

802.11ac (VHT40)

CHANNEL	TX Channel 151	DETECTOR FUNCTION	Quasi-Peak (QP)
FREQUENCY RANGE	9kHz ~ 1GHz		

ANTENNA POLARITY & TEST DISTANCE: HORIZONTAL AT 3 M

NO.	FREQ. (MHz)	EMISSION LEVEL (dBuV/m)	LIMIT (dBuV/m)	MARGIN (dB)	ANTENNA HEIGHT (m)	TABLE ANGLE (Degree)	RAW VALUE (dBuV)	CORRECTION FACTOR (dB/m)
1	30.92	28.0 QP	40.0	-12.0	1.00 H	128	42.5	-14.5
2	65.21	26.3 QP	40.0	-13.7	3.00 H	269	40.8	-14.5
3	99.36	31.3 QP	43.5	-12.2	2.00 H	257	48.6	-17.3
4	124.92	27.8 QP	43.5	-15.7	1.50 H	265	42.4	-14.6
5	217.95	28.4 QP	46.0	-17.6	1.50 H	138	43.9	-15.5
6	715.44	26.7 QP	46.0	-19.3	2.00 H	83	30.4	-3.7

REMARKS:

1. Emission Level(dBuV/m) = Raw Value(dBuV) + Correction Factor(dB/m)
2. Correction Factor(dB/m) = Antenna Factor(dB/m) + Cable Factor(dB) – Pre-Amplifier Factor(dB)
3. Margin value = Emission Level – Limit value
4. The other emission levels were very low against the limit of frequency range 30MHz~1000MHz.
5. The emission levels were very low against the limit of frequency range 9kHz~30MHz: the amplitude of spurious emissions attenuated more than 20 dB below the permissible value to be report.

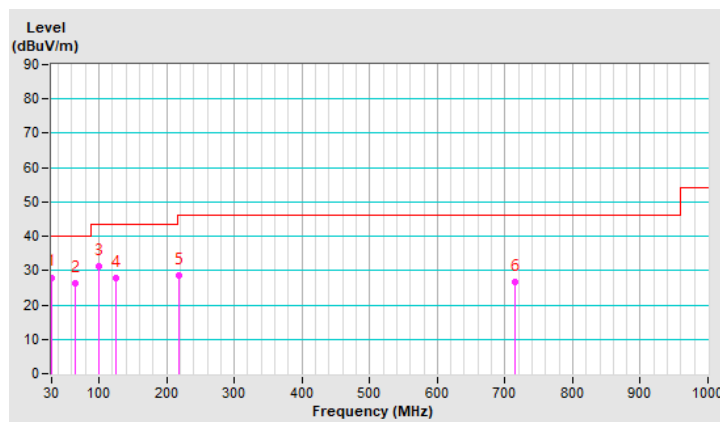

CHANNEL	TX Channel 151	DETECTOR FUNCTION	Quasi-Peak (QP)
FREQUENCY RANGE	9kHz ~ 1GHz		

ANTENNA POLARITY & TEST DISTANCE: VERTICAL AT 3 M

NO.	FREQ. (MHz)	EMISSION LEVEL (dBuV/m)	LIMIT (dBuV/m)	MARGIN (dB)	ANTENNA HEIGHT (m)	TABLE ANGLE (Degree)	RAW VALUE (dBuV)	CORRECTION FACTOR (dB/m)
1	36.26	36.0 QP	40.0	-4.0	1.00 V	360	49.9	-13.9
2	55.12	36.8 QP	40.0	-3.2	1.00 V	174	49.9	-13.1
3	80.78	31.5 QP	40.0	-8.5	1.50 V	170	49.5	-18.0
4	99.60	27.6 QP	43.5	-15.9	1.50 V	224	44.9	-17.3
5	160.57	26.0 QP	43.5	-17.5	1.00 V	198	39.0	-13.0
6	250.01	28.6 QP	46.0	-17.4	2.00 V	144	42.5	-13.9

REMARKS:

1. Emission Level(dBuV/m) = Raw Value(dBuV) + Correction Factor(dB/m)
2. Correction Factor(dB/m) = Antenna Factor(dB/m) + Cable Factor(dB) – Pre-Amplifier Factor(dB)
3. Margin value = Emission Level – Limit value
4. The other emission levels were very low against the limit of frequency range 30MHz~1000MHz.
5. The emission levels were very low against the limit of frequency range 9kHz~30MHz: the amplitude of spurious emissions attenuated more than 20 dB below the permissible value to be report.

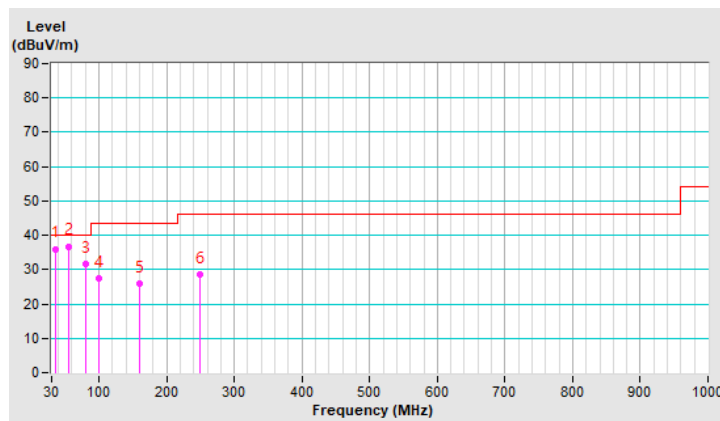

4.2 Conducted Emission Measurement

4.2.1 Limits of Conducted Emission Measurement

Frequency (MHz)	Conducted Limit (dBuV)	
	Quasi-peak	Average
0.15 - 0.5	66 - 56	56 - 46
0.50 - 5.0	56	46
5.0 - 30.0	60	50

Note: 1. The lower limit shall apply at the transition frequencies.

2. The limit decreases in line with the logarithm of the frequency in the range of 0.15 to 0.50MHz.

4.2.2 Test Instruments

DESCRIPTION & MANUFACTURER	MODEL NO.	SERIAL NO.	CALIBRATED DATE	CALIBRATED UNTIL
Test Receiver R&S	ESCS 30	847124/029	Oct. 24, 2018	Oct. 23, 2019
Line-Impedance Stabilization Network (for EUT) R&S	ESH3-Z5	848773/004	Oct. 22, 2018	Oct. 21, 2019
Line-Impedance Stabilization Network (for Peripheral) R&S	ESH3-Z5	835239/001	Mar. 17, 2019	Mar. 16, 2020
50 ohms Terminator	N/A	3	Oct. 22, 2018	Oct. 21, 2019
RF Cable	5D-FB	COCCAB-001	Sep. 28, 2018	Sep. 27, 2019
Fixed attenuator EMCI	STI02-2200-10	003	Mar. 14, 2019	Mar. 13, 2020
Software BVADT	BVADT_Cond_V7.3.7.4	NA	NA	NA

Note:

1. The calibration interval of the above test instruments are 12 months and the calibrations are traceable to NML/ROC and NIST/USA.
2. The test was performed in Conduction 1.
- 3 Tested Date: Sep. 25, 2019

4.2.3 Test Procedure

- The EUT was placed 0.4 meters from the conducting wall of the shielded room with EUT being connected to the power mains through a line impedance stabilization network (LISN). Other support units were connected to the power mains through another LISN. The two LISNs provide 50 ohm/ 50uH of coupling impedance for the measuring instrument.
- Both lines of the power mains connected to the EUT were checked for maximum conducted interference.
- The frequency range from 150kHz to 30MHz was searched. Emission levels under (Limit - 20dB) was not recorded.

NOTE: All modes of operation were investigated and the worst-case emissions are reported.

4.2.4 Deviation from Test Standard

No deviation.

4.2.5 Test Setup

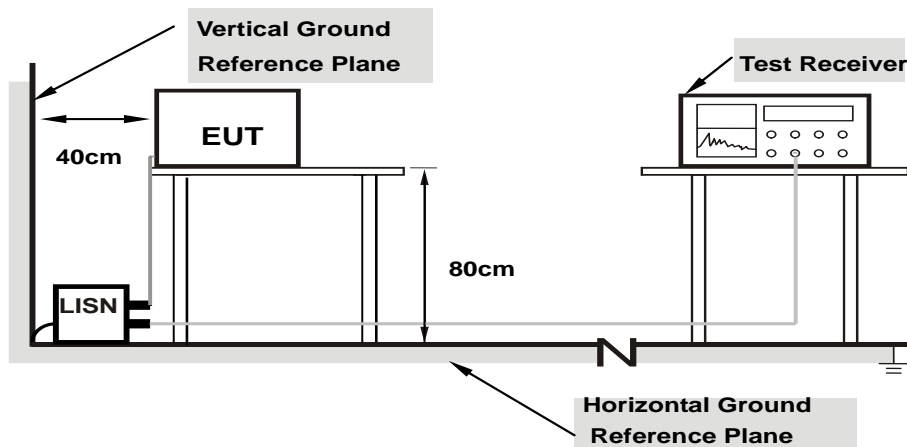

Note: 1.Support units were connected to second LISN.

For the actual test configuration, please refer to the attached file (Test Setup Photo).

4.2.6 EUT Operating Condition

Same as 4.1.6.

4.2.7 Test Results

Phase	Line (L)	Detector Function	Quasi-Peak (QP) / Average (AV)
-------	----------	-------------------	--------------------------------

No	Freq. [MHz]	Corr. Factor	Reading Value [dB (uV)]		Emission Level [dB (uV)]		Limit [dB (uV)]		Margin (dB)	
		(dB)	Q.P.	AV.	Q.P.	AV.	Q.P.	AV.	Q.P.	AV.
	1	0.15000	9.97	45.55	29.08	55.52	39.05	66.00	56.00	-10.48
2	0.23594	9.98	34.26	22.28	44.24	32.26	62.24	52.24	-18.00	-19.98
3	0.54453	10.00	32.38	26.59	42.38	36.59	56.00	46.00	-13.62	-9.41
4	12.09766	10.80	38.87	33.05	49.67	43.85	60.00	50.00	-10.33	-6.15
5	14.20703	10.95	31.95	27.02	42.90	37.97	60.00	50.00	-17.10	-12.03
6	29.49609	11.67	23.86	19.02	35.53	30.69	60.00	50.00	-24.47	-19.31

REMARKS:

1. Q.P. and AV. are abbreviations of quasi-peak and average individually.
2. The emission levels of other frequencies were very low against the limit.
3. Margin value = Emission level - Limit value
4. Correction factor = Insertion loss + Cable loss
5. Emission Level = Correction Factor + Reading Value.

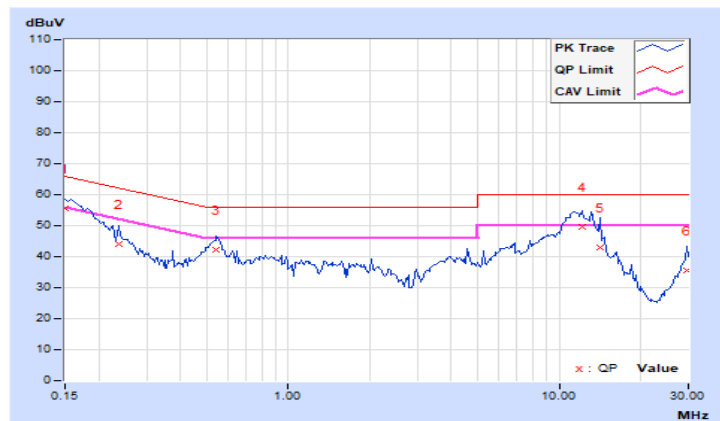

Phase	Neutral (N)	Detector Function	Quasi-Peak (QP) / Average (AV)
-------	-------------	-------------------	--------------------------------

No	Freq. [MHz]	Corr.	Reading Value		Emission Level		Limit		Margin	
		Factor	[dB (uV)]		[dB (uV)]		[dB (uV)]		(dB)	
	(dB)	Q.P.	AV.	Q.P.	AV.	Q.P.	AV.	Q.P.	AV.	
1	0.15000	9.95	46.43	30.48	56.38	40.43	66.00	56.00	-9.62	-15.57
2	0.16562	9.95	43.95	28.53	53.90	38.48	65.18	55.18	-11.28	-16.70
3	0.19297	9.96	40.51	28.38	50.47	38.34	63.91	53.91	-13.44	-15.57
4	0.54844	9.99	37.90	31.47	47.89	41.46	56.00	46.00	-8.11	-4.54
5	11.21875	10.63	38.40	33.59	49.03	44.22	60.00	50.00	-10.97	-5.78
6	13.20703	10.73	35.96	30.93	46.69	41.66	60.00	50.00	-13.31	-8.34

REMARKS:

1. Q.P. and AV. are abbreviations of quasi-peak and average individually.
2. The emission levels of other frequencies were very low against the limit.
3. Margin value = Emission level - Limit value
4. Correction factor = Insertion loss + Cable loss
5. Emission Level = Correction Factor + Reading Value.

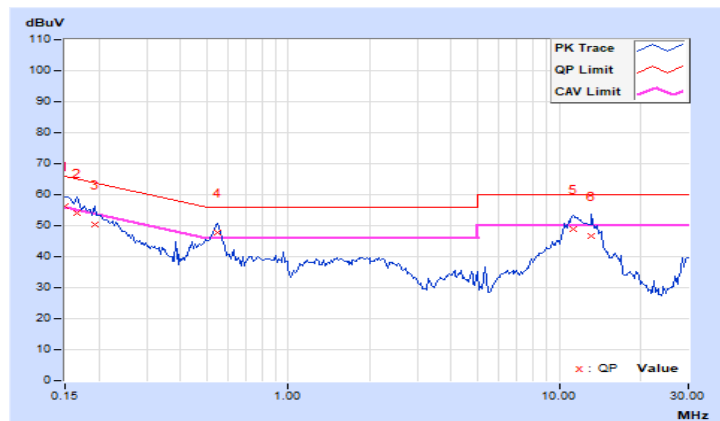

4.3 Transmit Power Measurement

4.3.1 Limits of Transmit Power Measurement

Operation Band	EUT Category		Limit
U-NII-1		Outdoor Access Point	1 Watt (30 dBm) (Max. e.i.r.p \leq 125mW(21 dBm) at any elevation angle above 30 degrees as measured from the horizon)
		Fixed point-to-point Access Point	1 Watt (30 dBm)
		Indoor Access Point	1 Watt (30 dBm)
	√	Client device	250mW (24 dBm)
U-NII-2A	---		250mW (24 dBm) or 11 dBm+10 log B*
U-NII-2C	---		250mW (24 dBm) or 11 dBm+10 log B*
U-NII-3	√		1 Watt (30 dBm)

*B is the 26 dB emission bandwidth in megahertz

Per KDB 662911 Method of conducted output power measurement on IEEE 802.11 devices,

Array Gain = 0 dB (i.e., no array gain) for $N_{ANT} \leq 4$;

Array Gain = 0 dB (i.e., no array gain) for channel widths ≥ 40 MHz for any N_{ANT} ;

Array Gain = $5 \log(N_{ANT}/N_{SS})$ dB or 3 dB, whichever is less for 20-MHz channel widths with $N_{ANT} \geq 5$.

For power measurements on all other devices: Array Gain = $10 \log(N_{ANT}/N_{SS})$ dB.

4.3.2 Test Setup

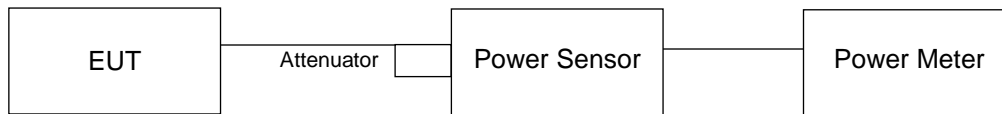

4.3.3 Test Instruments

Refer to section 4.1.2 to get information of above instrument.

4.3.4 Test Procedure

Method PM is used to perform output power measurement, trigger and gating function of wide band power meter is enabled to measure max output power of TX on burst. Duty factor is not added to measured value.

4.3.5 Deviation from Test Standard

No deviation.

4.3.6 EUT Operating Condition

The software provided by client to enable the EUT under transmission condition continuously at lowest, middle and highest channel frequencies individually.

4.3.7 Test Result

802.11a

Channel	Channel Frequency (MHz)	Maximum Conducted Power (mW)	Maximum Conducted Power (dBm)	Power Limit (dBm)	Pass/Fail
36	5180	56.885	17.55	24	Pass
40	5200	95.94	19.82	24	Pass
48	5240	65.013	18.13	24	Pass
149	5745	62.951	17.99	30	Pass
157	5785	63.096	18.00	30	Pass
165	5825	63.241	18.01	30	Pass

802.11ac (VHT20)

Chan.	Chan. Freq. (MHz)	Maximum Conducted Power (dBm)		Total Power (mW)	Total Power (dBm)	Limit (dBm)	Pass / Fail
		Chain 0	Chain 1				
36	5180	16.31	15.74	80.253	19.04	24	Pass
40	5200	16.78	16.53	92.621	19.67	24	Pass
48	5240	16.55	16.18	86.681	19.38	24	Pass
149	5745	17.90	17.40	116.614	20.67	30	Pass
157	5785	17.38	17.50	110.936	20.45	30	Pass
165	5825	17.74	17.59	116.841	20.68	30	Pass

802.11ac (VHT40)

Chan.	Chan. Freq. (MHz)	Maximum Conducted Power (dBm)		Total Power (mW)	Total Power (dBm)	Limit (dBm)	Pass / Fail
		Chain 0	Chain 1				
38	5190	11.90	11.44	29.42	14.69	24	Pass
46	5230	17.36	16.70	101.224	20.05	24	Pass
151	5755	17.65	17.98	121.016	20.83	30	Pass
159	5795	16.71	17.52	103.375	20.14	30	Pass

802.11ac (VHT80)

Chan.	Chan. Freq. (MHz)	Maximum Conducted Power (dBm)		Total Power (mW)	Total Power (dBm)	Limit (dBm)	Pass / Fail
		Chain 0	Chain 1				
42	5210	12.03	12.74	34.752	15.41	24	Pass
155	5775	14.92	15.60	67.354	18.28	30	Pass

4.4 Occupied Bandwidth Measurement

4.4.1 Test Setup



4.4.2 Test Instruments

Refer to section 4.1.2 to get information of above instrument.

4.4.3 Test Procedure

The transmitter output was connected to the spectrum analyzer through an attenuator. The bandwidth of the fundamental frequency was measured by spectrum analyzer with resolution bandwidth in the range of 1% to 5% of the anticipated emission bandwidth, and a video bandwidth at least 3x the resolution bandwidth and set the detector to SAMPLE. The width of a frequency band such that, below the lower and above the upper frequency limits, the mean powers emitted are each equal to a specified percentage 0.5% of the total mean power of a given emission.

4.4.4 Test Results

802.11a

Channel	Channel Frequency (MHz)	Occupied Bandwidth (MHz)
36	5180	20.76
40	5200	29.76
48	5240	19.92
149	5745	21.96
157	5785	23.40
165	5825	26.04

802.11ac (VHT20)

Channel	Channel Frequency (MHz)	Occupied Bandwidth (MHz)	
		Chain 0	Chain 1
36	5180	18.12	17.88
40	5200	18.24	18.12
48	5240	18.00	18.00
149	5745	25.80	29.57
157	5785	25.20	23.16
165	5825	28.20	23.28

802.11ac (VHT40)

Channel	Channel Frequency (MHz)	Occupied Bandwidth (MHz)	
		Chain 0	Chain 1
38	5190	36.24	36.48
46	5230	38.40	37.44
151	5755	51.12	55.92
159	5795	41.04	52.80

802.11ac (VHT80)

Channel	Channel Frequency (MHz)	Occupied Bandwidth (MHz)	
		Chain 0	Chain 1
42	5210	75.36	74.88
155	5775	75.84	77.76

Spectrum Plot of Max Value

802.11a_CH40

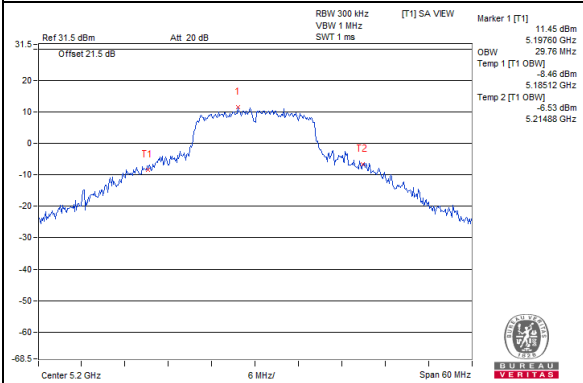

802.11ac (VHT20)_Chain1 / CH149

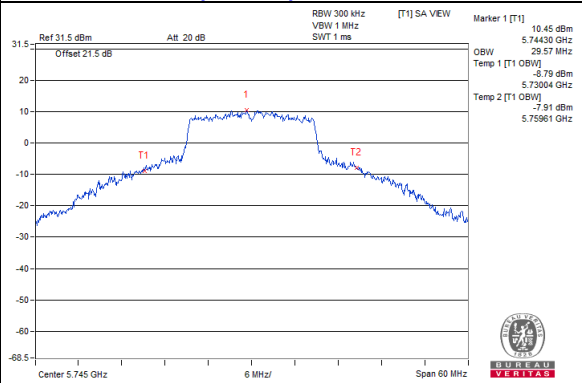

802.11ac (VHT40)_Chain1 / CH151

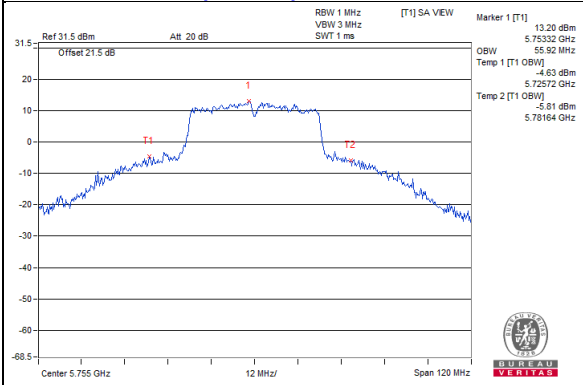

802.11ac (VHT80)_Chain1 / CH155

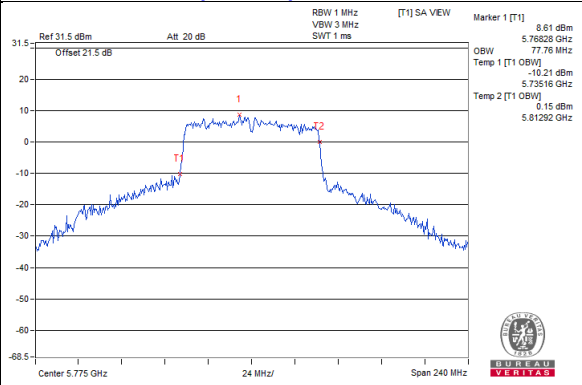

Spectrum Plot for near by DFS band (DFS is required, if 99% OCP straddle into U-NII-2A band)

802.11a_CH48

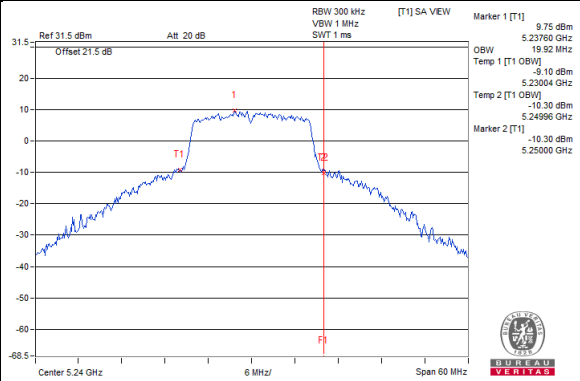

802.11ac(VHT20)_Chain0 / CH48

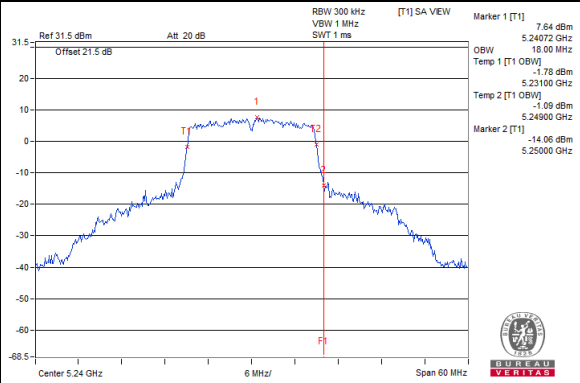

802.11ac(VHT20)_Chain1 / CH48

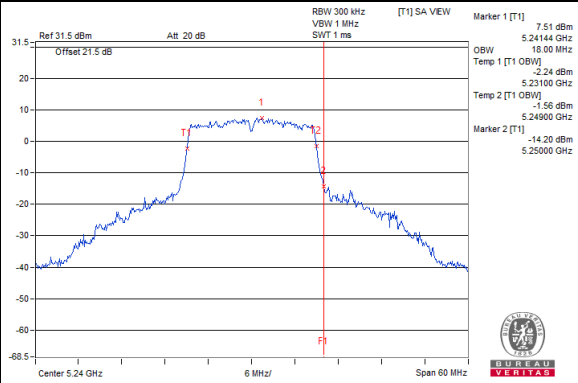

**Spectrum Plot for near by DFS band
(DFS is required, if 99% OCP straddle into U-NII-2A band)**

802.11ac(VHT40)_Chain0 / CH46

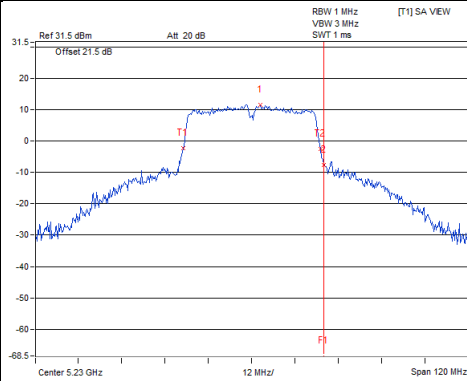

802.11ac(VHT40)_Chain1 / CH46

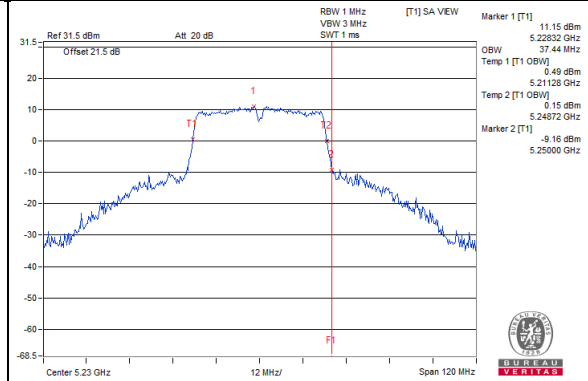

802.11ac(VHT80)_Chain0 / CH42

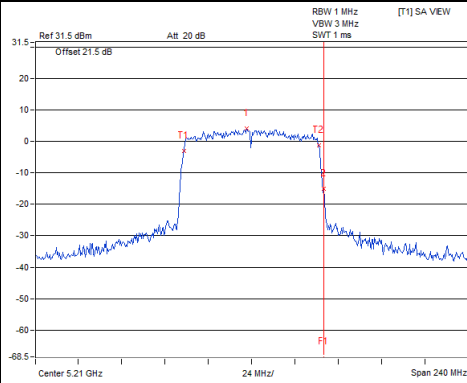

802.11ac(VHT80)_Chain1 / CH42

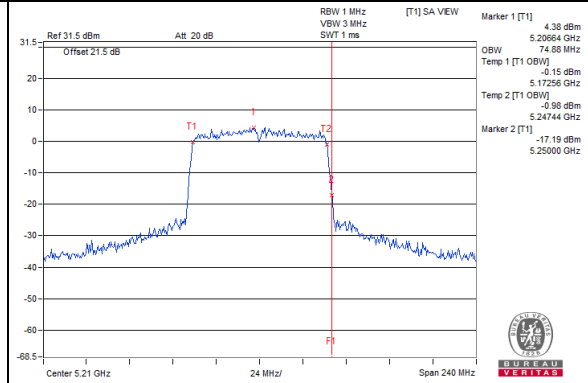

**Spectrum Plot for near by DFS band
(DFS is required, if 99% OCP straddle into U-NII-2C band)**

802.11a_Chain0 / CH149

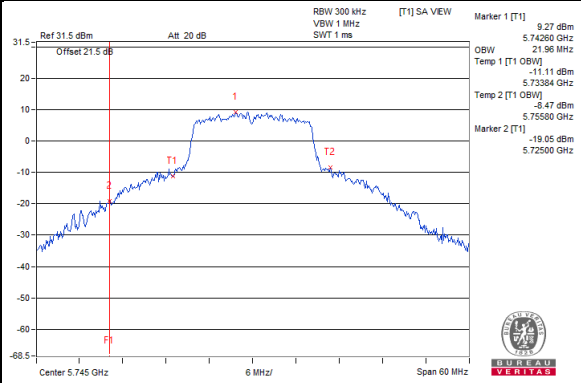

802.11ac(VHT20)_Chain0 / CH149

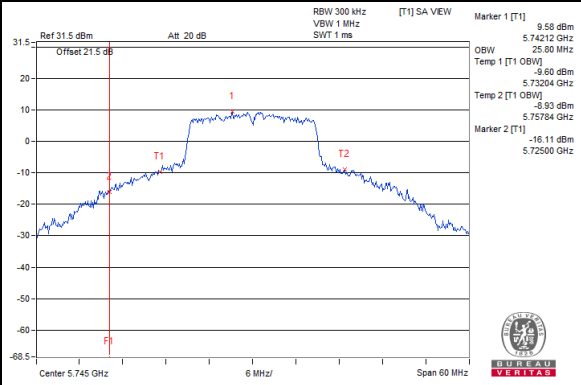

802.11ac(VHT20)_Chain1 / CH149

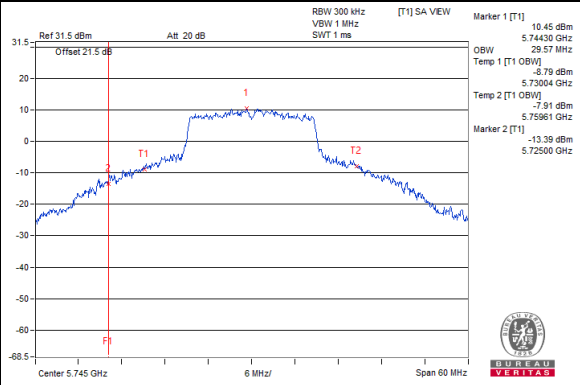

Spectrum Plot for near by DFS band (DFS is required, if 99% OCP straddle into U-NII-2C band)

802.11ac(VHT40)_Chain0 / CH151

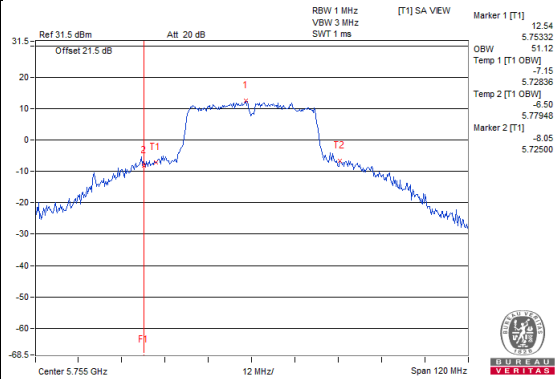

802.11ac(VHT40)_Chain1 / CH151

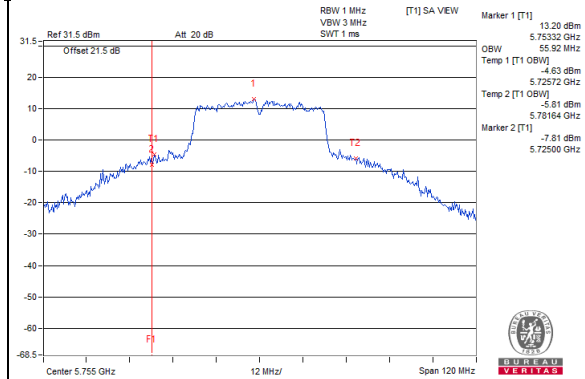

802.11ac(VHT80)_Chain0 / CH155

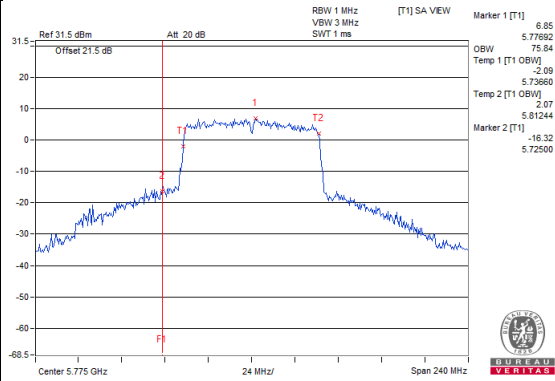

802.11ac(VHT80)_Chain1 / CH155

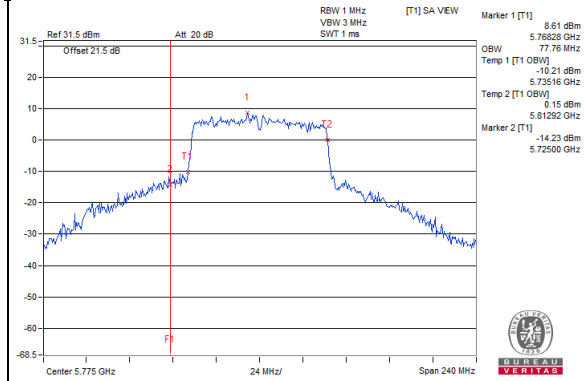

4.5 Peak Power Spectral Density Measurement

4.5.1 Limits of Peak Power Spectral Density Measurement

Operation Band	EUT Category		Limit
U-NII-1		Outdoor Access Point	17dBm/ MHz
		Fixed point-to-point Access Point	
		Indoor Access Point	
	√	Client device	11dBm/ MHz
U-NII-2A			11dBm/ MHz
U-NII-2C			11dBm/ MHz
U-NII-3		√	30dBm/ 500kHz

4.5.2 Test Setup

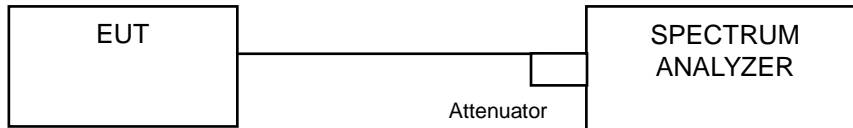

4.5.3 Test Instruments

Refer to section 4.1.2 to get information of above instrument.

4.5.4 Test Procedure

For U-NII-1:

Using method SA-2

1. Set span to encompass the entire emission bandwidth (EBW) of the signal.
2. Set RBW = 1 MHz, Set VBW ≥ 3 MHz, Detector = RMS
3. Sweep time = auto, trigger set to “free run”.
4. Trace average at least 100 traces in power averaging mode.
5. Record the max value and add 10 log (1/duty cycle)

For U-NII-3:

1. Set span to encompass the entire emission bandwidth (EBW) of the signal.
2. Set RBW = 300 kHz, Set VBW ≥ 1 MHz, Detector = RMS
3. Use the peak marker function to determine the maximum power level in any 300 kHz band segment within the fundamental EBW.
4. Scale the observed power level to an equivalent value in 500 kHz by adjusting (reducing) the measured power by a bandwidth correction factor (BWCF) where $BWCF = 10\log(500\text{ kHz}/300\text{kHz})$
5. Sweep time = auto, trigger set to “free run”.
6. Trace average at least 100 traces in power averaging mode.
7. Record the max value and add 10 log (1/duty cycle)

4.5.5 Deviation from Test Standard

No deviation.

4.5.6 EUT Operating Condition

Same as Item 4.3.6.

4.5.7 Test Results

For U-NII-1: 802.11a

Chan.	Chan. Freq. (MHz)	PSD W/O Duty Factor (dBm/MHz)	Duty Factor (dB)	Total PSD With Duty Factor (dBm/MHz)	MAX. Limit (dBm/MHz)	Pass / Fail
36	5180	5.42	0.28	5.70	11	Pass
40	5200	6.92	0.28	7.20	11	Pass
48	5240	4.73	0.28	5.01	11	Pass

Note: 1. Refer to section 3.3 for duty cycle spectrum plot.

802.11ac (VHT20)

Chan.	Chan. Freq. (MHz)	PSD W/O Duty Factor (dBm/MHz)		Duty Factor (dB)	Total PSD With Duty Factor (dBm/MHz)	MAX. Limit (dBm/MHz)	Pass / Fail
		Chain 0	Chain 1				
36	5180	2.96	2.29	0.23	5.88	8.99	Pass
40	5200	2.01	3.72	0.23	6.19	8.99	Pass
48	5240	1.75	2.29	0.23	5.27	8.99	Pass

Note: 1. Method a) of power density measurement of KDB 662911 is using for calculating total power density. Total power density is summing entire spectra across corresponding frequency bins on the various outputs by computer.

2. Directional gain = $5\text{dBi} + 10\log(2) = 8.01\text{dBi} > 6\text{dBi}$, so the power density limit shall be reduced to $11 - (8.01 - 6) = 8.99\text{dBm}$.

3. Refer to section 3.3 for duty cycle spectrum plot.

802.11ac (VHT40)

Chan.	Chan. Freq. (MHz)	PSD W/O Duty Factor (dBm/MHz)		Duty Factor (dB)	Total PSD With Duty Factor (dBm/MHz)	MAX. Limit (dBm/MHz)	Pass / Fail
		Chain 0	Chain 1				
38	5190	-6.24	-5.25	0.49	-2.22	8.99	Pass
46	5230	-0.27	-1.96	0.49	2.47	8.99	Pass

Note: 1. Method a) of power density measurement of KDB 662911 is using for calculating total power density. Total power density is summing entire spectra across corresponding frequency bins on the various outputs by computer.

2. Directional gain = $5\text{dBi} + 10\log(2) = 8.01\text{dBi} > 6\text{dBi}$, so the power density limit shall be reduced to $11 - (8.01 - 6) = 8.99\text{dBm}$.

3. Refer to section 3.3 for duty cycle spectrum plot.

802.11ac (VHT80)

Chan.	Chan. Freq. (MHz)	PSD W/O Duty Factor (dBm/MHz)		Duty Factor (dB)	Total PSD With Duty Factor (dBm/MHz)	MAX. Limit (dBm/MHz)	Pass / Fail
		Chain 0	Chain 1				
42	5210	-7.49	-6.76	1.14	-2.96	8.99	Pass

- Note:**
- Method a) of power density measurement of KDB 662911 is using for calculating total power density. Total power density is summing entire spectra across corresponding frequency bins on the various outputs by computer.
 - Directional gain = $5\text{dBi} + 10\log(2) = 8.01\text{dBi} > 6\text{dBi}$, so the power density limit shall be reduced to $11 - (8.01 - 6) = 8.99\text{dBm}$.
 - Refer to section 3.3 for duty cycle spectrum plot.

Spectrum Plot of Worst Value

802.11a_CH40

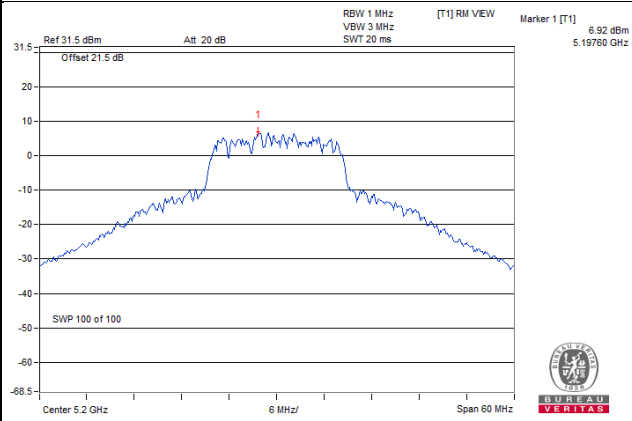

802.11ac (VHT20)_Chain 1 / CH40

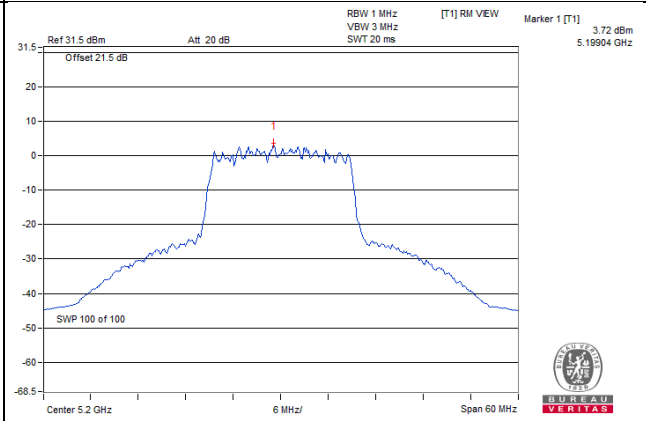

802.11ac (VHT40)_Chain 0 / CH46

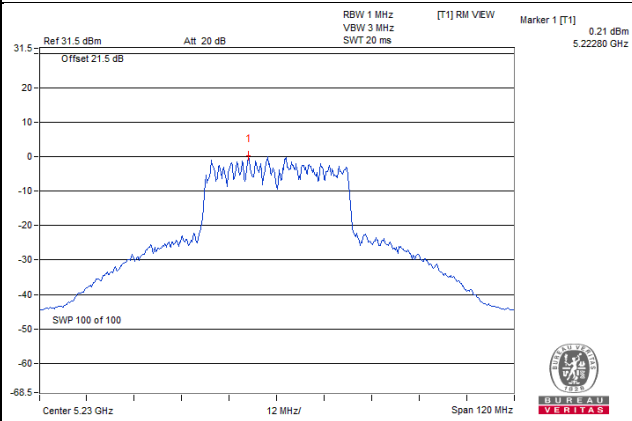

802.11ac (VHT80)_Chain 1 / CH42

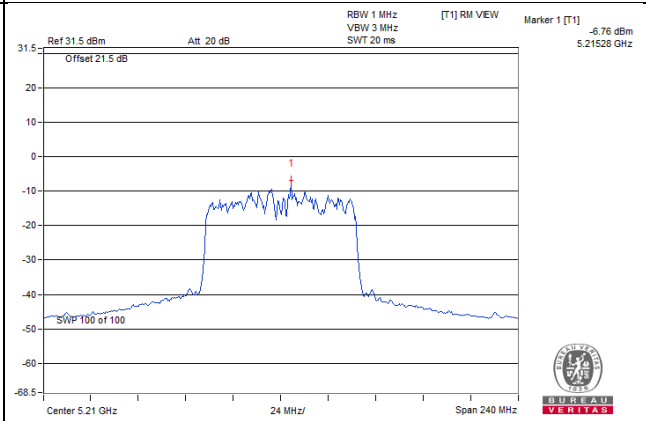

For U-NII-3:
802.11a

Chan.	Freq. (MHz)	PSD W/O Duty Factor (dBm/300kHz)	Duty Factor (dB)	PSD With Duty Factor (dBm/300kHz)	PSD (dBm/500kHz)	Limit (dBm/500kHz)	Pass /Fail
149	5745	-4.08	0.28	-3.80	-1.58	30	Pass
157	5785	-3.79	0.28	-3.51	-1.29	30	Pass
165	5825	-3.86	0.28	-3.58	-1.36	30	Pass

Note: 1. Refer to section 3.3 for duty cycle spectrum plot.

802.11ac (VHT20)

Chan.	Freq. (MHz)	PSD (dBm/300kHz)		Duty Factor (dB)	Total PSD		Total PSD (dBm/500kHz)	Limit (dBm/500kHz)	Pass /Fail
		Chain 0	Chain 1		mW/300kHz	dBm/300kHz			
149	5745	-3.99	-3.77	0.23	0.8633	-0.64	1.58	27.99	Pass
157	5785	-4.32	-6.59	0.23	0.6212	-2.07	0.15	27.99	Pass
165	5825	-4.87	-6.18	0.23	0.5977	-2.24	-0.02	27.99	Pass

- Note:**
- Method b) Measure and sum spectral maxima across the outputs of KDB 662911 is using for calculating total power density.
 - Directional gain = $5\text{dBi} + 10\log(2) = 8.01\text{dBi} > 6\text{dBi}$, so the power density limit shall be reduced to $30 - (8.01 - 6) = 27.99\text{dBm}$.
 - Refer to section 3.3 for duty cycle spectrum plot.

802.11ac (VHT40)

Chan.	Freq. (MHz)	PSD (dBm/300kHz)		Duty Factor (dB)	Total PSD		Total PSD (dBm/500kHz)	Limit (dBm/500kHz)	Pass /Fail
		Chain 0	Chain 1		mW/300kHz	dBm/300kHz			
151	5755	-8.29	-8.61	0.49	0.3204	-4.94	-2.72	27.99	Pass
159	5795	-9.04	-9.39	0.49	0.2687	-5.71	-3.49	27.99	Pass

- Note:**
- Method b) Measure and sum spectral maxima across the outputs of KDB 662911 is using for calculating total power density.
 - Directional gain = $5\text{dBi} + 10\log(2) = 8.01\text{dBi} > 6\text{dBi}$, so the power density limit shall be reduced to $30 - (8.01 - 6) = 27.99\text{dBm}$.
 - Refer to section 3.3 for duty cycle spectrum plot.

802.11ac (VHT80)

Chan.	Freq. (MHz)	PSD (dBm/300kHz)		Duty Factor (dB)	Total PSD		Total PSD (dBm/500kHz)	Limit (dBm/500kHz)	Pass /Fail
		Chain 0	Chain 1		mW/300kHz	dBm/300kHz			
155	5775	-14.11	-13.58	1.14	0.10759	-9.68	-7.46	27.99	Pass

- Note:**
- Method b) Measure and sum spectral maxima across the outputs of KDB 662911 is using for calculating total power density.
 - Directional gain = $5\text{dBi} + 10\log(2) = 8.01\text{dBi} > 6\text{dBi}$, so the power density limit shall be reduced to $30 - (8.01 - 6) = 27.99\text{dBm}$.
 - Refer to section 3.3 for duty cycle spectrum plot.

Spectrum Plot of Worst Value

802.11a_CH157

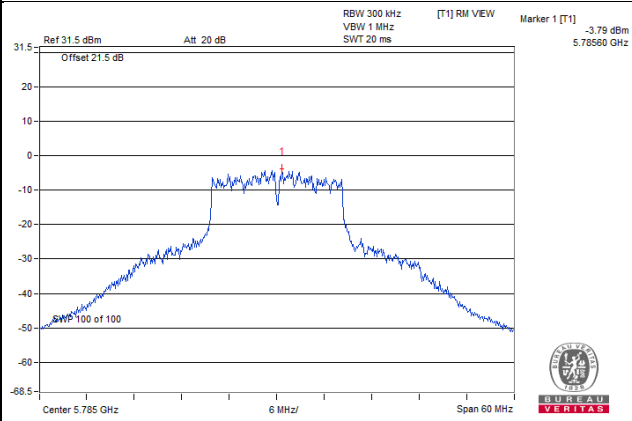

802.11ac (VHT20)_Chain 1 / CH149

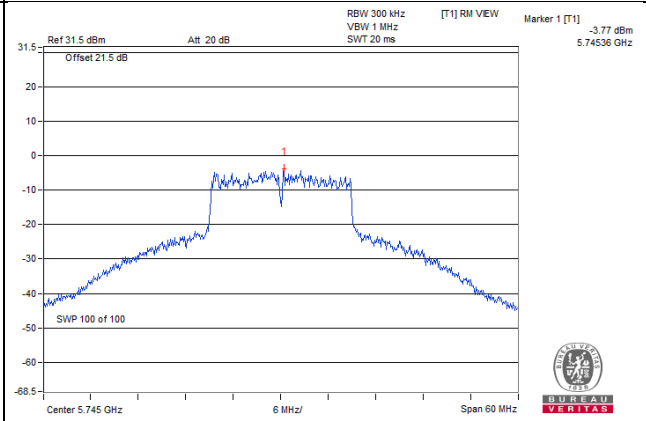

802.11ac (VHT40)_Chain 0 / CH151

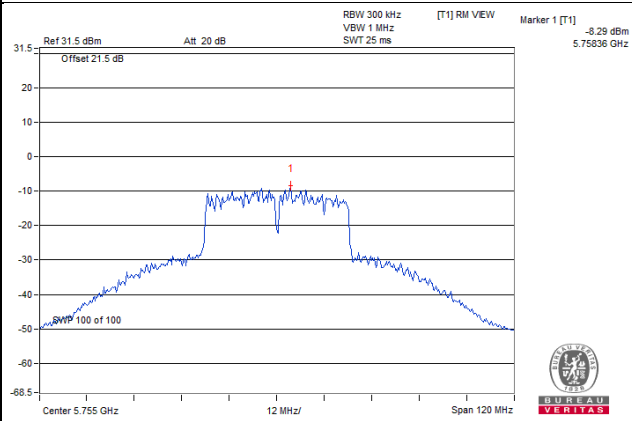

802.11ac (VHT80)_Chain 1 / CH155

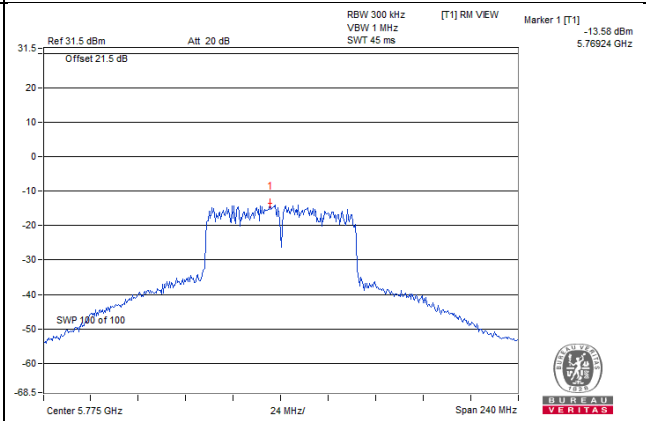

4.6 Frequency Stability Measurement

4.6.1 Limits of Frequency Stability Measurement

The frequency of the carrier signal shall be maintained within band of operation

4.6.2 Test Setup

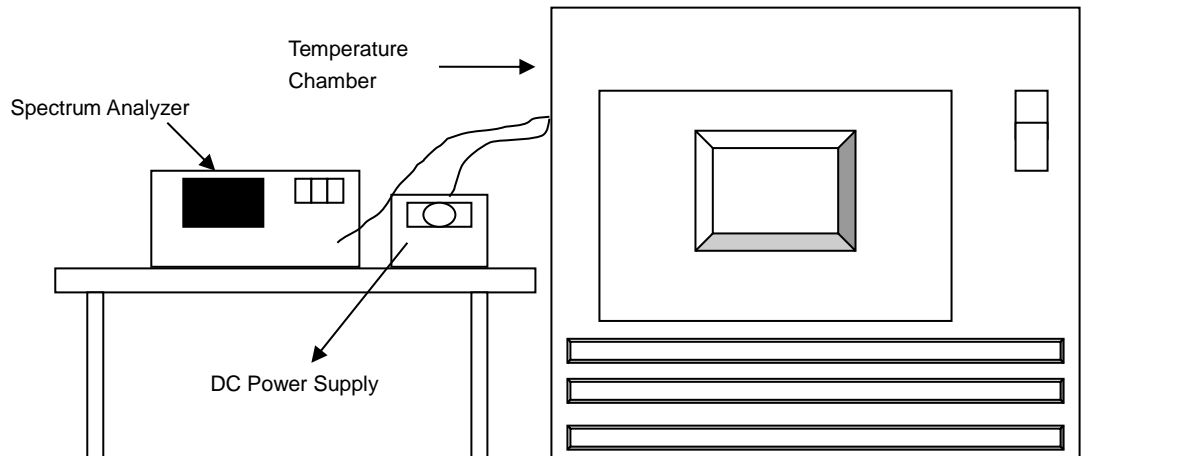

4.6.3 Test Instruments

Refer to section 4.1.2 to get information of above instrument.

4.6.4 Test Procedure

- The EUT was placed inside the environmental test chamber and powered by nominal DC voltage.
- Turn the EUT on and couple its output to a spectrum analyzer.
- Turn the EUT off and set the chamber to the highest temperature specified.
- Allow sufficient time (approximately 30 min) for the temperature of the chamber to stabilize, turn the EUT on and measure the operating frequency after 2, 5, and 10 Minutes.
- Repeat step (d) with the temperature chamber set to the next desired temperature until measurements down to the lowest specified temperature have been completed..
- The test chamber was allowed to stabilize at +20 degree C for a minimum of 30 Minutes. The supply voltage was then adjusted on the EUT from 85% to 115% and the frequency record.

4.6.5 Deviation from Test Standard

No deviation.

4.6.6 EUT Operating Condition

Set the EUT transmit at un-modulation mode to test frequency stability.

4.6.7 Test Results

Frequency Stability Versus Temp.									
Operating Frequency: 5180 MHz									
TEMP. (°C)	Power Supply (Vdc)	0 Minute		2 Minutes		5 Minutes		10 Minutes	
		Measured Frequency (MHz)	Pass/Fail	Measured Frequency (MHz)	Pass/Fail	Measured Frequency (MHz)	Pass/Fail	Measured Frequency (MHz)	Pass/Fail
70	3.3	5180.0238	Pass	5180.0207	Pass	5180.0217	Pass	5180.0212	Pass
60	3.3	5180.0245	Pass	5180.0201	Pass	5180.021	Pass	5180.0243	Pass
50	3.3	5180.016	Pass	5180.0129	Pass	5180.0135	Pass	5180.0126	Pass
40	3.3	5180.0106	Pass	5180.0114	Pass	5180.0103	Pass	5180.012	Pass
30	3.3	5179.9932	Pass	5179.9937	Pass	5179.9921	Pass	5179.9906	Pass
20	3.3	5180.0129	Pass	5180.0123	Pass	5180.0142	Pass	5180.0132	Pass
10	3.3	5179.994	Pass	5179.9957	Pass	5179.9946	Pass	5179.9924	Pass
0	3.3	5179.984	Pass	5179.9832	Pass	5179.9853	Pass	5179.9876	Pass
-10	3.3	5179.9904	Pass	5179.9894	Pass	5179.9868	Pass	5179.9887	Pass
-20	3.3	5180.0046	Pass	5180.0024	Pass	5180.0033	Pass	5180.0023	Pass
-30	3.3	5180.0238	Pass	5180.0217	Pass	5180.0253	Pass	5180.024	Pass

Frequency Stability Versus Voltage									
Operating Frequency: 5180 MHz									
TEMP. (°C)	Power Supply (Vdc)	0 Minute		2 Minutes		5 Minutes		10 Minutes	
		Measured Frequency (MHz)	Pass/Fail	Measured Frequency (MHz)	Pass/Fail	Measured Frequency (MHz)	Pass/Fail	Measured Frequency (MHz)	Pass/Fail
20	3.795	5180.0128	Pass	5180.0115	Pass	5180.0144	Pass	5180.0126	Pass
	3.3	5180.0129	Pass	5180.0123	Pass	5180.0142	Pass	5180.0132	Pass
	2.805	5180.0127	Pass	5180.0121	Pass	5180.0142	Pass	5180.0124	Pass

4.7 6dB Bandwidth Measurement

4.7.1 Limits of 6dB Bandwidth Measurement

The minimum of 6dB Bandwidth Measurement is 0.5MHz.

4.7.2 Test Setup

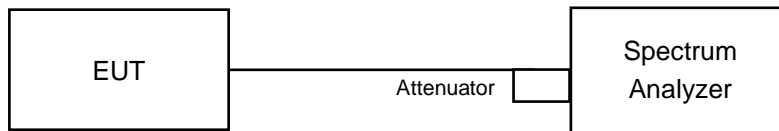

4.7.3 Test Instruments

Refer to section 4.1.2 to get information of above instrument.

4.7.4 Test Procedure

MEASUREMENT PROCEDURE REF

- a. Set resolution bandwidth (RBW) = 100kHz
- b. Set the video bandwidth (VBW) $\geq 3 \times$ RBW, Detector = Peak.
- c. Trace mode = max hold.
- d. Sweep = auto couple.
- e. Measure the maximum width of the emission that is constrained by the frequencies associated with the two amplitude points (upper and lower) that are attenuated by 6 dB relative to the maximum level measured in the fundamental emission

4.7.5 Deviation from Test Standard

No deviation.

4.7.6 EUT Operating Condition

The software provided by client to enable the EUT under transmission condition continuously at lowest, middle and highest channel frequencies individually.

4.7.7 Test Results

802.11a

Channel	Frequency (MHz)	6dB Bandwidth (MHz)	Minimum Limit (MHz)	Pass / Fail
149	5745	16.10	0.5	PASS
157	5785	16.07	0.5	PASS
165	5825	16.07	0.5	PASS

802.11ac (VHT20)

Channel	Frequency (MHz)	6dB Bandwidth (MHz)		Minimum Limit (MHz)	Pass / Fail
		Chain 0	Chain 1		
149	5745	16.97	17.56	0.5	PASS
157	5785	16.97	16.94	0.5	PASS
165	5825	16.93	16.95	0.5	PASS

802.11ac (VHT40)

Channel	Frequency (MHz)	6dB Bandwidth (MHz)		Minimum Limit (MHz)	Pass / Fail
		Chain 0	Chain 1		
151	5755	35.23	35.29	0.5	PASS
159	5795	35.32	35.29	0.5	PASS

802.11ac (VHT80)

Channel	Frequency (MHz)	6dB Bandwidth (MHz)		Minimum Limit (MHz)	Pass / Fail
		Chain 0	Chain 1		
155	5775	75.28	74.15	0.5	PASS

Spectrum Plot of Worst Value

802.11a_CH157

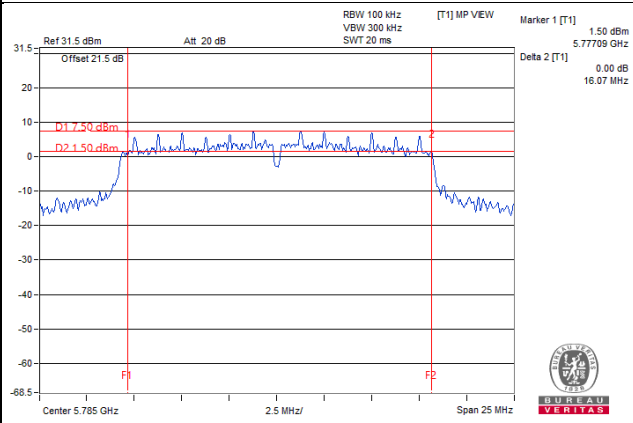

802.11ac (VHT20)_Chain 0 / CH165

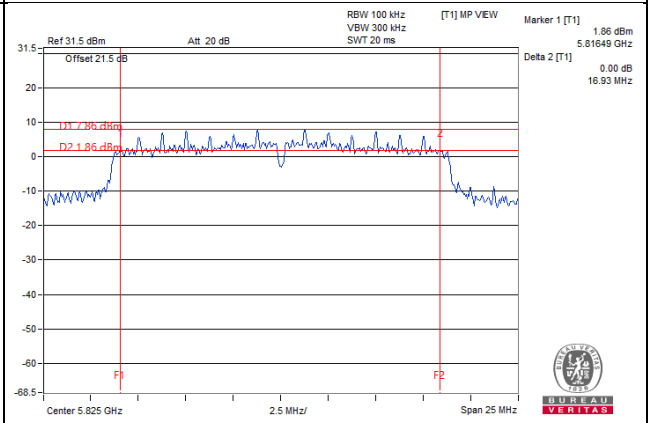

802.11ac (VHT40)_Chain 0 / CH151

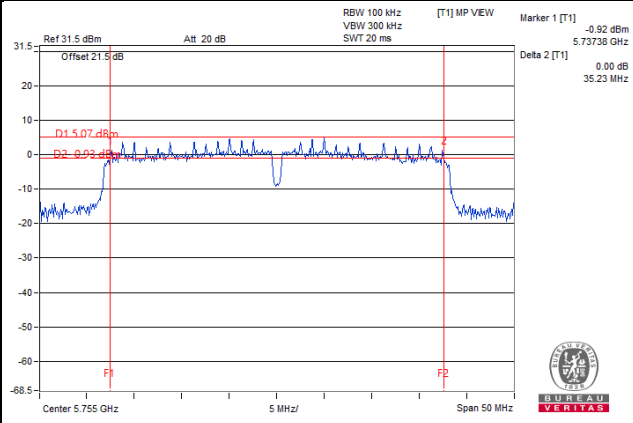

802.11ac (VHT80)_Chain 1 / CH155

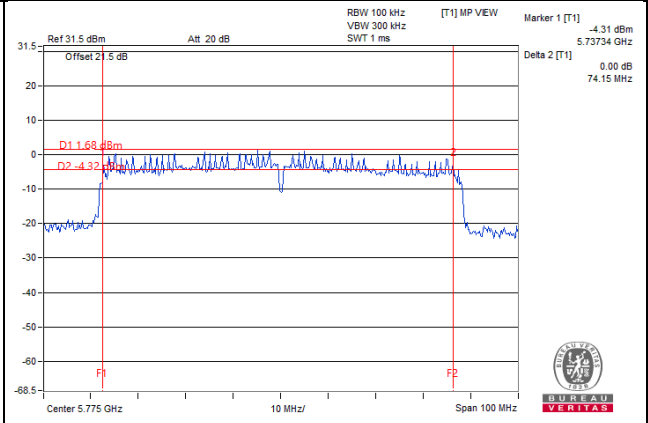

5 Pictures of Test Arrangements

Please refer to the attached file (Test Setup Photo).

Annex A- Radiated Out of Band Emission (OOBE) Measurement (For U-NII-3 band)

802.11a

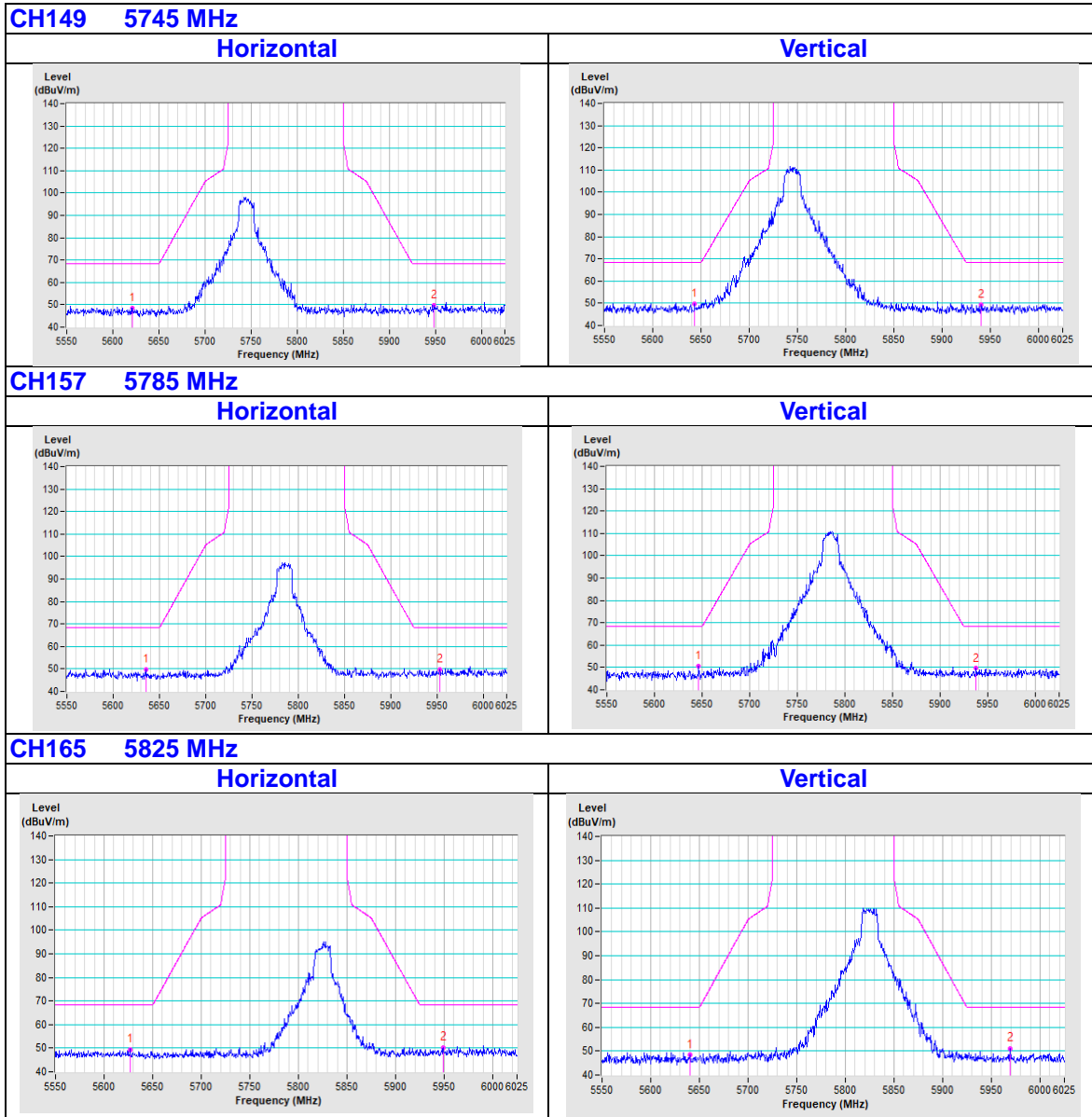

802.11ac (VHT20)

CH149 5745 MHz

Horizontal

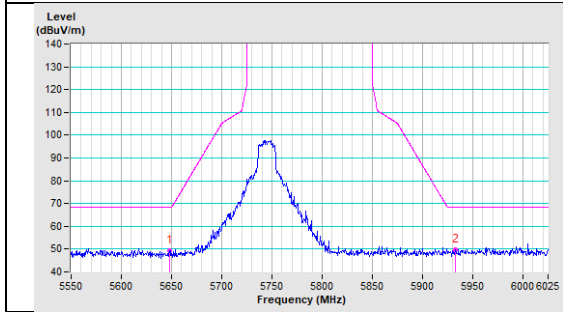

Vertical

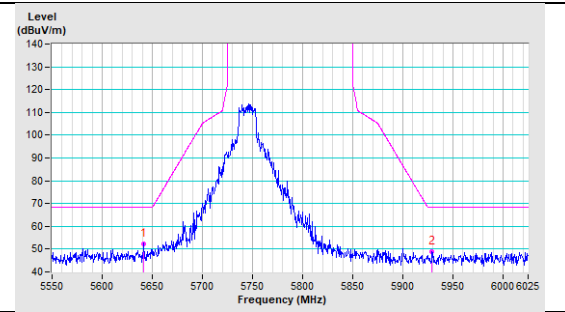

CH157 5785 MHz

Horizontal

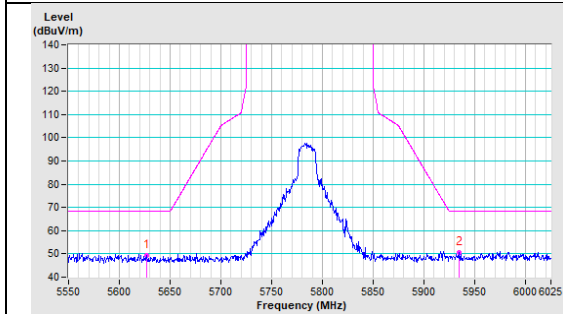

Vertical

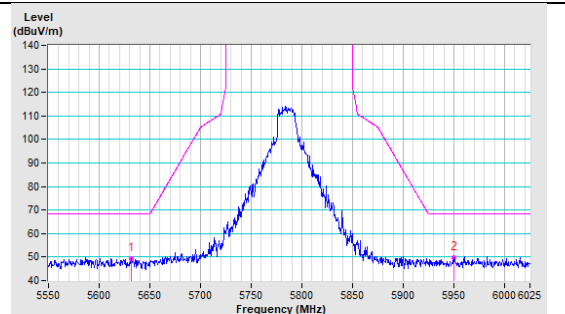

CH165 5825 MHz

Horizontal

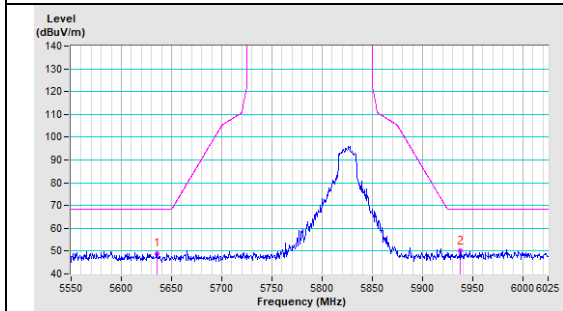

Vertical

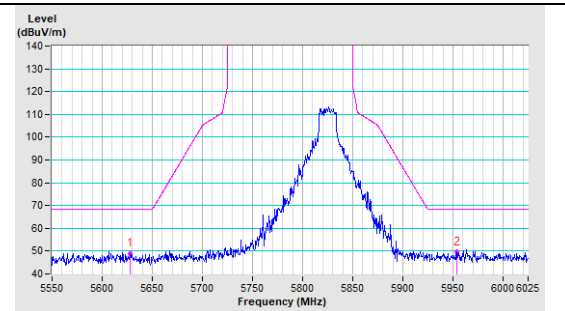

802.11ac (VHT40)

CH151 5755 MHz

Horizontal

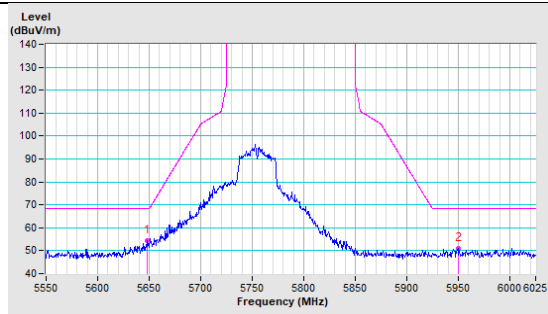

Vertical

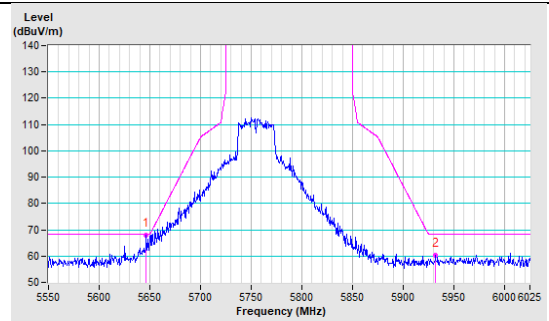

CH159 5795 MHz

Horizontal

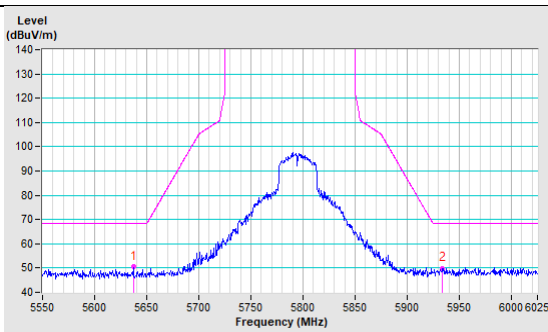

Vertical

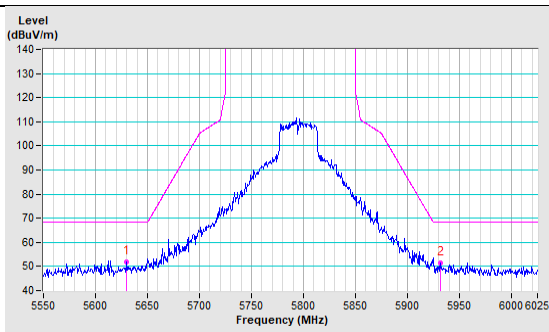

802.11ac (VHT80)

CH155 5775 MHz

Horizontal

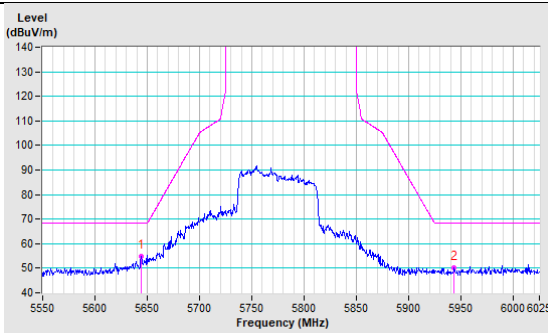

Vertical

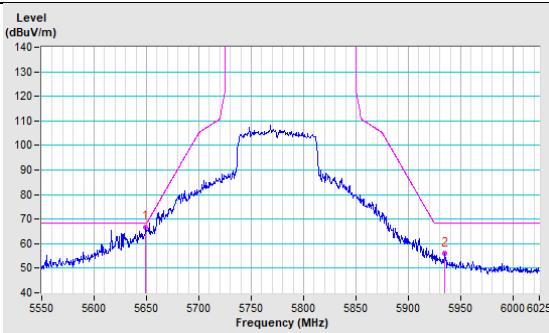

Appendix – Information of the Testing Laboratories

We, Bureau Veritas Consumer Products Services (H.K.) Ltd., Taoyuan Branch, were founded in 1988 to provide our best service in EMC, Radio, Telecom and Safety consultation. Our laboratories are FCC recognized accredited test firms and accredited according to ISO/IEC 17025.

If you have any comments, please feel free to contact us at the following:

Lin Kou EMC/RF Lab

Tel: 886-2-26052180

Fax: 886-2-26051924

Hsin Chu EMC/RF/Telecom Lab

Tel: 886-3-6668565

Fax: 886-3-6668323

Hwa Ya EMC/RF/Safety Lab

Tel: 886-3-3183232

Fax: 886-3-3270892

Email: service.adt@tw.bureauveritas.com

Web Site: www.bureauveritas-adt.com

The address and road map of all our labs can be found in our web site also.

--- END ---