Operator's Manual
Medium Duty

Contents

Safety	1
Emergency	2
Controls	3
Driving	4
Maintenance	5
Information	6

© 2023 PACCAR Inc. - All Rights Reserved

This manual illustrates and describes the operation of features or equipment which may be either standard or optional on this vehicle. This manual may also include a description of features and equipment which are no longer available or were not ordered on this vehicle. Please disregard any illustrations or descriptions relating to features or equipment which are not on this vehicle. PACCAR reserves the right to discontinue, change specifications, or change the design of its vehicles at any time without notice and without incurring any obligation. The information contained in this manual is proprietary to PACCAR. Reproduction, in whole or in part, by any means is strictly prohibited without prior written authorization from PACCAR Inc.

1

Chapter 1 | SAFETY

- What's New?..... 6
- Using this Manual..... 6
- Safety Messages and Notes..... 7
- Illustrations..... 8
- General Safety Instructions..... 8
- Data Recorder..... 11
- Environmental Protection Agency..... 11
- Repairs..... 11
- Additional Sources of Information..... 12
- Cab Access..... 13
- Deckplate Access..... 15
- How to Open the Hood..... 16
- Close the Hood..... 17
- Seat..... 18
- Vehicle Loading..... 24
- Visual Inspection While Approaching the Vehicle..... 25

Daily Checks..... 25
Weekly Checks..... 27
Systems Check..... 27

1

What's New?**Disposition: / Status:**

All altered/new topics will be marked with a pink box like this above them. Please keep an eye out for pink boxes as they provide important information to reviewers. These boxes and the "What's New?" topic will be removed from the manual before publication.

- Altered Topic - *How to Set Cruise Control Speed* on page 137
- Altered Topic - *Transmission, Failure* on page 79
- Altered Topic - *Ignition Key Switch* on page 95
- Altered Topic - *Upshifting and Downshifting* on page 105
- Altered Topic - *Brake System Malfunction* on page 73
- Altered Topic - *Automated Transmissions* on page 143
- Altered Topic - *Warning Lights and Indicators* on page 65
- Altered Topic - *Dash Switches* on page 83
- New Topic - *Transmission, Service* on page 79
- Altered Topic - *Engine Brake Indicator* on page 75
- Altered Topic - *Every 60,000 mi / 96,000 km / 6 mo* on page 204
- Altered Topic - *Every 120,000 miles / 193,000 km / 2 yr* on page 206
- New Topic - *Every 75,000 mi / 120,000 km* on page 206
- Altered Topic - *Every 750 mi / 1,207 km / 1 mo* on page 187
- Altered Topic - *Retarders* on page 153
- Altered Topic - *Steering Column Controls* on page 104
- Altered Topic - *Column Shifter (option)* on page 104
- Altered Topic - *How to Start the PTO* on page 133
- Altered Topic - *How to Stop the PTO* on page 134
- Altered Warning - *Fifth Wheel* on page 166
- New Topic - *Battery Telltale* on page 73
- Altered Topic - *Lights, Cab and Panel Dimmer Switch* on page 96
- Altered Topic - *Fuel Tank* on page 262
- Altered Topic - *Anti-Lock Brake Systems (ABS)* on page 175
- Altered Topic - *Transmission Mode* on page 104
- Altered Topic - *Power Take-off (PTO)* on page 101
- Altered Topic - *Menu Control Switch* on page 100
- Altered Topic - *Dash Switches* on page 83

Using this Manual

Please take the time to get acquainted with your vehicle by reading this Operator's Manual. We recommend that you read and understand this manual from beginning to end before you operate this equipment. This manual contains useful information for the safe and efficient operation of this equipment. It also provides service information, with an outline for performing safety checks and basic preventive maintenance inspections. We have tried to present the information you need to learn about functions, controls, and operation—and to present it as clearly as possible. We hope you will find this manual easy to use.

 NOTE

After you have read this manual, it should be stored in the cab for convenient reference and remain with this truck when sold.

Your vehicle may not have all the features or options mentioned in this manual. Therefore, you should pay careful attention to the instructions that pertain to just your vehicle. In addition, if your vehicle is equipped with special equipment or options not discussed in this manual, consult your dealer or the manufacturer of the equipment.

There are several tools built into this manual to help you find what you need quickly and easily; the first is the Quick Table of Contents. Located at the front of the manual, this table lists the main subjects covered and gives section numbers where you can find these subjects. Use the Quick Table of Contents to find information on a large subject and then use the detailed table of contents found on the first page of each chapter. Cross-referenced citations also help you get the information you need. If some other

part of the manual contains further information on the subject you are reading about, we will indicate that in a cross-reference like this: (See *Safety Messages and Notes* on page 7).

Finally, you will find a helpful Subject Index. It is in the back of the manual and alphabetically lists the subjects covered. All information contained in this manual is based on the latest production information available at the time of publication. Peterbilt Motors Company reserves the right to make changes at any time without notice.

Safety Messages and Notes

Read and follow ALL safety messages in this manual. When followed, injury to yourself and others, damage to equipment and/or property, or other unknown hazards are reduced. Both safety messages and notes are emphasized using a safety message symbol and one of three signal words: WARNING, CAUTION, or NOTE. **Do not** ignore any of these messages.

Warnings



Safety messages that follow this symbol and signal word provide a warning concerning operating procedures, actions, or a lack of action that could result in death or injury. An unheeded warning may also result in damage to equipment, property, or the environment. Warning messages will identify the hazard, how to avoid it, and the probable consequence of not avoiding the hazard.

Example:



WARNING

DO NOT change hot engine oil as you could be burned. Let the engine cool down before changing the engine oil. Failure to comply may result in death, personal injury, equipment damage, or property damage.

1

Cautions



Safety messages that follow this symbol and signal word provide a caution against operating procedures, actions, or a lack of action that could result in equipment, property, or environmental damage. Caution messages will identify the hazard, how to avoid it, and the probable consequence of not avoiding the hazard. Example:

	CAUTION
<p>DO NOT operate your vehicle with insufficient oil pressure as this will cause serious engine damage. Failure to comply may result in equipment or property damage.</p>	

Notes



Messages that follow this symbol and signal word provide important information

that, while not safety related, should still be followed. A note will provide information that may be useful to the reader: clarifying the topic, providing valuable insight into the topic or process, or saving the reader time and effort. Example:

	NOTE
<p>Pumping the accelerator pedal will not assist in starting the engine.</p>	

Illustrations

Some of the illustrations found in this manual are generic, and may not look exactly like the parts or assemblies you find installed on your vehicle. When an illustration differs from what you see physically present on your vehicle, the language describing the procedure will still be correct for your application.

General Safety Instructions



WARNING

Improper practices, carelessness, or ignoring safety messages – Warnings and Cautions – may cause death, personal injury, or equipment and property damage.

Before performing any repair, read and understand all of the safety precautions and warnings. The following is a list of general safety precautions that must be followed to provide personal safety. Failure to follow these instructions may cause death or injury. Special safety precautions are included in the procedures when they apply. Keep in mind that even a well-maintained vehicle must be operated within the range of its mechanical capabilities and the limits of its load ratings. See the Weight Ratings label on the driver's door edge. Every new vehicle is designed to conform to all Federal Motor Vehicle Safety Standards applicable at the time of

manufacture. Even with these safety features, continued safe and reliable operation depends upon regular vehicle maintenance. Follow the maintenance recommendations found in the Maintenance section. Following maintenance recommendations will help your vehicle maintain quality conditions. Make sure your vehicle is in top working condition before heading out on the road, it is the driver's duty to do so. Inspect the vehicle according to the Driver's Check List:

- Work areas should be dry, well lit, well ventilated; free from clutter, loose tools, parts, ignition sources, and hazardous substances.
- Wear protective glasses and protective shoes when working.
- Wear protective gloves when working with hot liquids or surfaces, and when working with components that have sharp edges.
- DO NOT wear loose-fitting or torn clothing. Tie back and/or tuck in long hair. Remove all jewelry when working.
- Before beginning any repair, disconnect the battery (negative [-]

cable) and discharge any capacitors.

- Put a "DO NOT OPERATE" tag in the operator's compartment or on the controls.
- Allow the engine to cool before slowly loosening the coolant fill cap to relieve the pressure from the cooling system.

**WARNING**

Removing the fill cap on a hot engine can cause scalding coolant to spray out and burn you badly. If the engine has been in operation within the previous 30 minutes, be very careful in removing the fill cap. Protect face, hands, and arms against escaping fluid and steam by covering the cap with a large, thick rag. DO NOT try to remove it until the surge tank cools down or if you see any steam or coolant escaping. Always remove the cap very slowly and carefully. Be ready to back off if any steam or coolant begins to escape. Failure to comply may result in death, personal injury, equipment or property damage.

- Always use wheel chocks or proper jack stands to support the vehicle or vehicle components before performing any service work. DO NOT work on anything that is supported only by lifting jacks or a hoist. Before resting a vehicle on jack stands, be sure the stands are rated for the load you will be placing on them.
- Before removing or disconnecting any lines, fittings, or related items, relieve all pressure in the air, oil, fuel, and cooling systems. Remain alert for possible pressure when disconnecting any device from a system that contains pressure. High-pressure oil or fuel can cause death or personal injury.
- Always wear protective clothing when working on any refrigerant lines and make sure that the workplace is well ventilated. Inhalation of fumes can cause death or personal injury. To protect the environment, liquid refrigerant systems must be properly emptied and filled using equipment that prevents the release of refrigerant gas. Federal law requires capturing and recycling refrigerant.

1

- When moving or lifting any heavy equipment or parts, make sure to use proper techniques and assistance. Ensure all lifting devices such as chains, hooks, or slings are in good condition and are rated for the correct load capacity. Make sure all lifting devices are positioned correctly.
- Corrosion inhibitors and lubricating oils may contain alkali. DO NOT get the substance in eyes and avoid prolonged or repeated contact with skin. DO NOT swallow. If ingested, seek immediate medical attention. DO NOT induce vomiting. In case of contact, immediately wash skin with soap and water. In case of harmful contact, immediately contact a physician. Always keep any chemicals OUT OF REACH OF CHILDREN.
- When working on the vehicle, be alert for hot parts on systems that have just been turned off, exhaust gas flow, and hot fluids in lines, tubes, and compartments. Contact with any hot surface may cause burns.
- Always use tools that are in good condition. Make sure you have the proper understanding of how to use the tools before performing any service work. Use only genuine replacement parts from PACCAR.
- Always use the same fastener part number (or equivalent) when replacing items. DO NOT use a fastener of lesser quality if replacements are necessary. (e.g., DO NOT replace a Metric 10.9 grade with 8.8 grade fastener).
- Always torque fasteners and fuel connections to the required specifications. Overtightening or under-tightening can allow leakage.
- Close the manual fuel valves prior to performing maintenance and repairs, and when storing the vehicle inside.
- DO NOT perform any repair when impaired, tired, fatigued, or after consuming alcohol or drugs that can impair your functioning.
- Some state and federal agencies in the United States of America have determined that used engine oil can be carcinogenic and can cause reproductive toxicity. Avoid

- inhalation of vapors, ingestion, and prolonged contact with used engine oil.
- Coolant is toxic. If not reused, dispose of coolant in accordance with local environmental regulations.

 CAUTION
Corrosive chemicals can damage the engine. DO NOT use corrosive chemicals on the engine. Failure to comply may result in equipment or property damage.

California Proposition 65 Warning

- Diesel engine exhaust and some of its constituents are known to the State of California to cause cancer, birth defects, and other reproductive harm.
- The catalyst substrate located in the Diesel Particulate Filter (DPF) contains vanadium pentoxide, which has been determined by the State of California to cause cancer. Always wear protective clothing and eye protection when handling the catalyst assembly. Dispose of

the catalyst in accordance with local regulations. If catalyst material gets into the eyes, immediately flood eyes with water for a minimum of 15 minutes. Avoid prolonged contact with skin. In case of contact, immediately wash skin with soap and water. In case of harmful contact, immediately contact a physician.

- Other chemicals in this vehicle are also known to the State of California to cause cancer, birth defects, or other reproductive harm.
- Battery posts, terminals, and related accessories contain lead and lead compounds, chemicals known to the State of California to cause cancer and reproductive harm. Wash hands after handling.

Data Recorder

California Vehicle Code - Section 9951 - Disclosure of Recording Device
Your vehicle may be equipped with one or more recording devices commonly referred to as "event data recorders" (EDR) or "sensing and diagnostic modules" (SDM).

If you are involved in an accident, the device(s) may have the ability to record vehicle data that occurred just prior to and/or during the accident. For additional information on your rights associated with the use of this data, contact:

- The California Department of Motor Vehicles - Licensing Operations Division
- <http://www.dmv.ca.gov/>

Environmental Protection Agency

Some of the ingredients in engine oil, hydraulic oil, transmission and axle oil, engine coolant, diesel fuel, air conditioning refrigerant (R12, R134a, and PAG oil), batteries, etc., may contaminate the environment if spilled or not disposed of properly.



WARNING

Diesel engine exhaust and some of its constituents are known to the State of California to cause cancer, birth defects, and other reproductive harm.

Other chemicals in this vehicle are also known to the State of California to cause cancer, birth defects or other reproductive harm. This warning requirement is mandated by California law (Proposition 65) and does not result from any change in the manner in which vehicles are manufactured.

Contact your local government agency for information concerning proper disposal.

Repairs



WARNING

DO NOT attempt maintenance or repair work without sufficient training, proper tools, and up-to-date service instructions. Perform only those tasks you are fully qualified to do. Failure to comply could place personnel at risk or make the vehicle unsafe, which may result in death, personal injury, equipment damage or property damage.

1

 **WARNING**

Modifying your vehicle can make it unsafe. Some modifications can affect your vehicle's electrical system, stability control system, or other important functions. Before modifying your vehicle, check with your dealer to make sure it can be done safely. Failure to comply may result in death, personal injury, equipment damage, or property damage.

 **CAUTION**

The installation of electronic devices to the On-board Diagnostics (OBD) connector, the vehicle Controller Area Network (CAN), or their associated wiring is not permitted. Doing so can adversely affect vehicle performance and/or cause fault codes to be recorded. The OBD connector is provided for temporary connection of service tools and for diagnostic purposes only.

Your dealer's service center is the best place to have your vehicle repaired. You

can find dealers all over the country with the equipment and trained personnel to get you back on the road quickly—and keep you there.

Your vehicle is a complex machine. Anyone attempting repairs on it needs proper mechanical training and the proper tools. However, all warranty repairs must be performed by an authorized service facility. If you aren't an experienced technician, or don't have the right equipment, please leave all repairs to an authorized service facility. They are the ones best equipped to do the job safely and correctly.

Maintenance Manuals

If you do decide to do any complex repair work, you will need the maintenance manuals. Order them from your authorized dealer. Please provide your Chassis Serial Number when you order, to be sure you get the correct manuals for your vehicle. Allow about four weeks for delivery. There will be a charge for these manuals.

Final Chassis Bill of Material

A complete, non-illustrated computer printout listing of the parts used to custom-build your vehicle is available through the

dealer from whom you purchased your vehicle.

Additional Sources of Information

Major component suppliers also supply operation manuals specific to their products. Additional manuals and other pieces of literature are included in the glove box literature package. Look for information on products such as the engine, driver's seat, transmission, axles, wheels, tires, anti-lock braking system/ electronic stability control (ABS/ESC), radio, fifth wheel, lane departure, and adaptive cruise control. If you are missing these pieces of literature, ask your dealer for copies.

Another place to learn more about trucking is from local truck driving schools. Contact one near you to learn about the courses they offer. Federal and state agencies, such as the Department of Licensing, also have information.

Cab Access

The following cab and frame entry/exit procedure recommendations were prepared with personal safety foremost in mind.



WARNING

Disposition: / Status:
Altered Warning. Please Review.

Always face toward the vehicle and DO NOT jump when entering or exiting the cab. Use the steps, handles, and anti-skid surfaces provided instead of components not designed for entry or exit. Always maintain at least three points of contact between your hands, feet, and the vehicle. Failure to comply may lead to a slip or fall resulting in death, personal injury, equipment damage, or property damage.

To help avoid personal injury due to a slip or fall

- Always face the vehicle when accessing or leaving the cab or frame access area.

- Use three points of contact (two feet one hand or one foot two hands) to grip the steps or handholds whenever possible and look where you are going.
- Use even more care when steps and handholds (or footwear) are wet, coated with ice, snow, mud, oil, fuel, or grease.



WARNING

Disposition: / Status:
New Warning. Please review.

Use care when entering, exiting, or climbing onto the vehicle when the steps, handholds, or footwear are wet, muddy, or coated with ice or snow. Failure to comply may lead to a slip or fall resulting in death, personal injury, equipment damage, or property damage.

- Do not step onto the surface of a fuel tank. A fuel tank is not a step. The tank surface can get very slippery, and you might not be able to prevent a fall. Use only the steps and handholds provided, and not the chain hooks, quarter fenders,

or other components not designed for that purpose.

- Do not climb onto and off the deckplate; use the steps and grab handle provided. If there is no deckplate, or if proper steps and grab handles are not provided, do not climb onto the area behind the cab.
- Keep the steps clean. Clean any fuel, oil, or grease off the steps before entering the cab.



WARNING

Clean any fuel, oil, or grease off of vehicle steps and handles before entering, exiting, or climbing onto the vehicle. Keep vehicle steps and handles clean! Failure to comply may lead to a slip or fall resulting in death, personal injury, equipment damage, or property damage.

1



WARNING

Always reinstall the battery compartment cover (step) before entering the cab. Without the battery cover in place, you could slip and fall, resulting in possible injury to yourself.



NOTE

Any alteration (adding bulkheads, headache racks, tool boxes, etc.) behind the cab that affects the utilization of installed grab handles, deckplates, or frame access steps should comply with Federal Motor Carrier Safety Regulation 399.

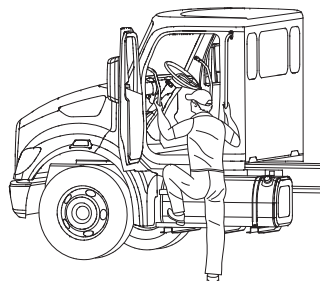

How to Lock and Unlock the Cab Doors

The vehicle has one key for both the cab doors and the ignition. Frame-mounted tool box locks and locking fuel tank caps each have separate, individual keys.



WARNING

To help lessen the chance and/or severity of death or personal injury in case of an accident, always lock the doors while driving. Along with using the lap shoulder belts properly, locking the doors helps prevent the doors from inadvertently opening and occupants from being ejected from the vehicle.

To lock or unlock the doors from outside the cab:

- To lock, rotate the key toward the rear of the vehicle (clockwise).
- To unlock, rotate the key toward the front of the vehicle (counter clockwise).

Operate Door Locks using Remote Keyless Entry

Disposition: / Status:

Deletion of radio sources listing (television, radio, and cell phone transmitters) in the description, per SME request. Please review.

Open doors will not lock using the key fob. The key fob should be within 30 feet (9 meters) of the vehicle and should not be in proximity of other radio frequency sources. To unlock the cab doors:

1. Press the **UNLOCK** button once. The driver's door will unlock and the parking lights will come on for 40 seconds.
2. Quickly press the **UNLOCK** button a second time within 5 seconds to unlock the passenger door.
3. Press the **LOCK** button. The doors will lock and the parking lights will come on for 2 seconds.

Deckplate Access



WARNING

Always reinstall steps before entering the cab or accessing the deckplate. Without steps you could slip and fall.

Failure to comply may result in personal injury or death.



WARNING

Clean any fuel, oil, or grease off of vehicle steps and handles before entering, exiting, or climbing onto the vehicle. Keep vehicle steps and handles clean! Failure to comply may lead to a slip or fall resulting in death, personal injury, equipment damage, or property damage.



WARNING

When you are climbing onto and off the deckplate, maintain at least three points of contact with your hands on the grab handles and your feet on the steps. Always face toward the vehicle when entering or exiting the cab and look where you are going. Failure to comply may result in death or personal injury.

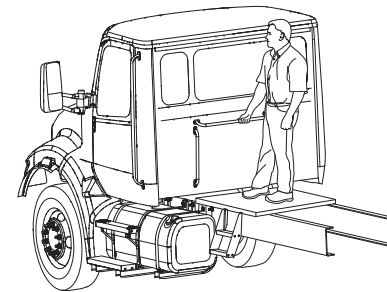
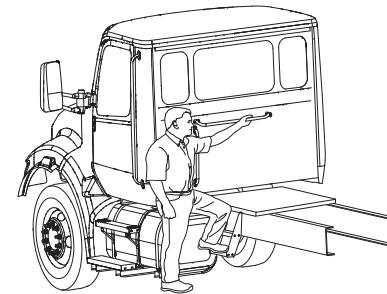

1

WARNING

When stepping onto a surface to enter the cab or access the deckplate, only use the steps and grab handles installed and designed for that purpose. Failure to use the proper steps and grab handles could cause a fall which may result in death or personal injury.

NOTE

Any alteration (adding bulkheads, headache racks, tool boxes, etc.) behind the cab that affects the utilization of installed grab handles, deckplates, or frame access steps should comply with Federal Motor Carrier Safety Regulation 399.

How to Open the Hood

WARNING

Always open the hood with both feet planted firmly on the ground and one

or both hands on the hood. If you lose your footing, the hood may open or close uncontrollably. Failure to comply may result in death, personal injury, equipment damage, or property damage.

WARNING

Always ensure the hood lock has engaged whenever the hood is opened. Failure to lock the hood open may result in the hood closing uncontrollably, which may result in death, personal injury, equipment damage, or property damage.

CAUTION

A hood not latched securely could open during operation and cause vehicle damage. Be sure to latch the hood securely.

Access the engine by opening the hood. The hood is held in the closed position by two latches called hold-downs. The hold-

downs are mounted on either side of the vehicle hood.

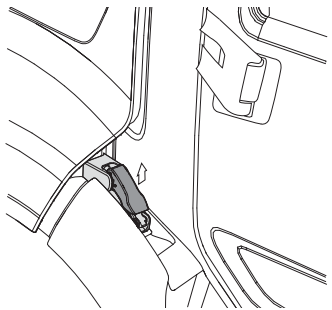

1. Release the hood hold-downs.



2. Place one or both hands at top of hood front, and tilt hood forward by pulling hood. Keep both feet on the ground for stability.

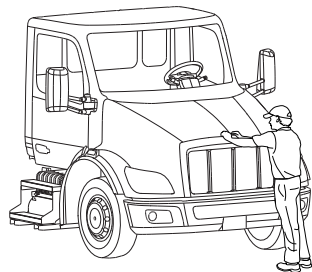

*Tilt hood forward until it stops.
When fully opened, the hood lock
engages automatically.*

- 3. Ensure hood lock is engaged.¹

Hood Lock

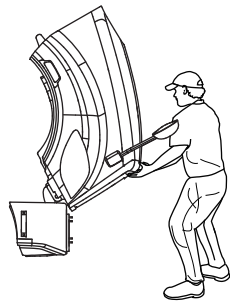
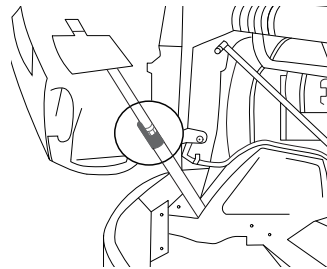

Hood Lock - Engaged

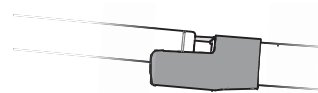

Hood Lock - NOT Engaged

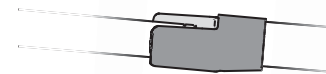

A hood that closes uncontrollably may result in personal injury.

Close the Hood



WARNING

Disposition: / Status:

Changed Warning, please review.
Combined two warnings into one.

Before closing the hood, look and ensure no objects are in the way. Close the hood in a controlled manner and DO NOT let go with hands firmly grasping the hood and feet on a stable, non-slip surface. Failure to comply may result in death, personal injury, equipment damage, or property damage.

¹ When hood lock is engaged, the strut is visible above the lock.

1

WARNING

Before closing the hood, be sure the area is clear—no people or objects are in the way. Failure to do so may result in death or personal injury.

The hood lock will only be engaged if the vehicle hood is fully open. Once it is fully open, the latch will automatically engage and will need to be disengaged by the operator. The release lever for the hood lock is located near the front hinge of the hood.

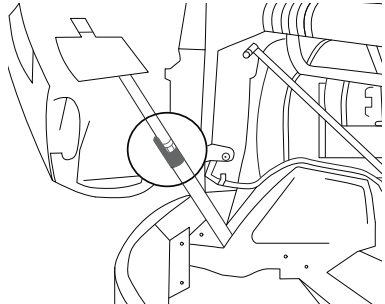

To disengage the hood lock, press the collar toward the strut until a snap is felt and the collar surrounds the strut bar.

When the hood lock is disengaged, the strut will no longer be visible above the hood lock collar.

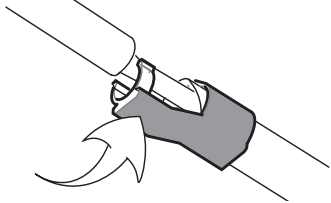

When closing the hood, be sure that you maintain the same point of contact (top of hood) to control the movement of the hood as it closes. Gently lower the hood into place to avoid damage to the hood or cab.

Seat

This section covers the operation and safe use of your vehicle's seats. For further information on features and adjustment of the seat, see the manufacturer's service and operator's manuals, included with the vehicle.

Seat Adjustment

WARNING

DO NOT adjust the driver's seat while the vehicle is moving. The seat could move suddenly and unexpectedly and can cause the driver to lose control of the vehicle. Make all adjustments to the seat while the vehicle is stopped. After adjusting the seat and before driving off, always check to ensure that the seat is firmly latched in position. Failure to comply may result in property damage, personal injury, or death.

Standard Driver's Seat

The standard driver's seat can be adjusted forward and rearward as well as up and down. The seat back angle can also be adjusted. These three movements are each controlled by levers located either beneath or at the sides of the seat.

Reclining Seats

Raise the seat all the way up so that the seat will tilt back and completely clear objects behind you.

**WARNING**

DO NOT drive or ride with your seat back in the reclined position. You could be injured by sliding under the seat belts in a collision. Failure to comply may result in personal injury or death.

Safety Restraint Belts

Disposition: / Status:
Revised topic. Please review.

Safety restraints have proven to be the single most effective means available for reducing the potential for either death or personal injury in motor vehicle accidents. Seat belts have a locking mechanism. The system adjusts automatically to a person's size and movements as long as the pull on the belt is slow. Hard braking or a collision locks the belt. The belt will also lock when driving up or down a steep hill or in a sharp curve.

Unbelted riders could be thrown into the windshield or other parts of the cab or could be thrown out of the cab. They could strike another person. Injuries can be much worse when riders are unbelted. Always

observe user warnings pertaining to safety restraints. Your vehicle is equipped with a seat belt indicator lamp located on the dash.

**WARNING**

Disposition: / Status:
Revised warning. Please review.

DO NOT drive the vehicle without your seat belt and any passengers' belts properly fastened. Failure to comply may result in death or personal injury.

**WARNING**

DO NOT use the swivel function while a passenger is in the seat and the vehicle is in motion. The seat belt will not provide proper protection if the passenger is not facing forward and the vehicle is in an accident. Failure to comply may result in death or personal injury.

Correct Seat Belt Use

Correct Placement of Lap Belt



Correct Placement of Shoulder Belt



1

Incorrect Seat Belt Use

Lap Belt Too High on the Hip



Shoulder Belt Incorrectly Under the Arm



Seat Belt Twisted



Seat Belt Use During Pregnancy

Pregnant women should always wear seat belts. The lap belt portion must be worn snugly and as low as possible across the pelvis. To avoid pressure on the abdomen, the belt must never pass over the waist. A properly worn seat belt may significantly reduce the risks to woman and baby in the event of a crash.



Safety Restraint Protocol

- DO NOT wear a seat belt over rigid or breakable objects in or on your clothing, such as eye glasses, pens, keys, etc., as these may cause injury in an accident.
- Any authorized person sleeping in your vehicle while it is moving should use the sleeper bunk restraint.
- Any authorized person sitting in the sleeper area on the sofa bed (if equipped) while it is moving should use a seat belt.
- A responsible operator makes sure that everyone in the vehicle rides or sleeps safely. The operator is responsible to inform any

passengers or co-drivers how to properly use the seat belts and sleeper bunk restraints in the vehicle.

- DO NOT strap in more than one person with each belt.
- Keep seat belt and sleeper bunk restraint buckles free of any obstruction that may prevent secure locking.
- Damaged or worn belts in the cab or sleeper subjected to excessive stretch forces from normal wear, must be replaced. They may not protect you if you are in an accident.
- Any safety restraints (seat belt or sleeper bunk restraint) that have been subjected to an accident should be inspected for any loose (attaching) hardware or damaged buckles.
- Belts that show damage to any part of the assembly (such as webbing, bindings, buckles, or retractors) should be replaced.
- DO NOT allow safety restraints (seat belt or sleeper bunk restraint) to get caught in the door, bunk, or seat hardware, or rub against

sharp objects. This can damage the safety restraint.

- All safety restraints must be kept clean or the retractors may not work properly.
- Keep safety restraints clean by following the care label on the belts. Let them dry completely before allowing them to retract or be stowed away. Do not use bleach or dye to clean since chemicals can weaken them.
- When a safety restraint is not in use, make sure it is fully wound up on its retractor or is stowed. Put the belt or restraint tongue in its properly stowed position. This reduces the possibility of the tongue becoming a striking object in case of a sudden stop.
- DO NOT modify or disassemble the safety restraints in your vehicle, or they will not be able to keep you and your passengers safe.
- If any safety restraint is not working properly, see an authorized dealer for repair or replacement.

How to Use a Seat Belt

Disposition: / Status:

Revised topic IAW seat belt terminology updates. Please review.

Follow these steps to fasten your seat belt. Make sure that anyone riding with you does the same.



WARNING

Disposition: / Status:

Revised warning IAW seat belt terminology updates

Proper seat belt adjustment and use is important to maximize occupant safety. Failure to wear or adjust the seat belt properly may result in death or personal injury.

To fasten the belt:

1. Grasp the belt tongue.
2. Pull belt in a continuous slow motion across your chest and lap.
3. Insert belt tongue into buckle on inboard side of seat.
4. Push down until the tongue is securely locked with an audible click.
5. Pull belt to check for proper fastening and adjustment.

1

- a. Pull shoulder belt to make sure belt fits snugly across the chest and pelvis.
- b. There should be less than one inch (25 mm) gap between the body and the belt.
- c. The shoulder restraint must always be positioned over the shoulder. Never allow a shoulder belt to rest against the neck or be worn under the arm.
- d. Make sure that any slack is wound up on the retractor and that the belt is not twisted.

If the belt is locked, lean back to remove any tension in the belt. After releasing the belt, allow the belt to retract completely by guiding the belt tongue until the belt comes to a stop.

Disposition: / Status:
Updated content. Please review.

To unfasten the belt, push the release button on the buckle. The seat belt indicator lamp will turn on when the driver's seat belt is unfastened.

Disposition: / Status:
Seat belt graphic's style updated per SME request.

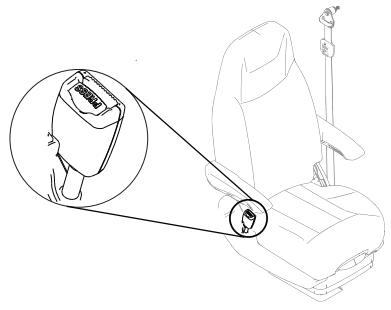

Tether Belts

Make sure that the tether belt is attached to the cab floor and seat frame. It should be routed through the buckle on each side. Often the attachments are made using a split-type hook. Make sure both halves of the hook are around the anchor bracket.

! WARNING

DO NOT remove, modify, or replace the tether belt system with a different tether system. A failed or missing tether belt could allow the seat base to fully extend in the event of an accident. Failure to comply may result in death or personal injury.

! WARNING

Failure to adjust external tether belts properly can cause excessive movement of the seat in an accident. Tether belts should be adjusted so that they are taut when the seat is in its most upward and forward position. Failure to comply may result in death or personal injury.

Adjust an external tether by either lengthening or shortening the strap. To lengthen it:

1. Turn the buckle to a right angle to the webbing.
2. Then pull the buckle.
3. To shorten the tether, pull on the strap.

Komfort Latch Feature

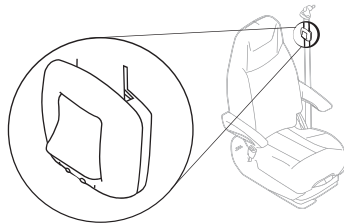

WARNING

DO NOT set the Komfort Latch with too much slack. Too much slack may reduce the effectiveness of the seat

belt. Failure to comply may result in death or personal injury.

To eliminate cinching, simply activate the Komfort Latch device located on the seat belt webbing at the appropriate time:

1. Adjust the seat to its proper driving position.
2. Latch the seat belt.
3. If available, adjust the seat belt height adjuster to a comfortable driving position.
4. While seated appropriately, push the "on" button to engage the Komfort Latch.
5. Lean forward in the seat until you hear a "click."
6. Return to normal driving position, and the Komfort Latch maintains the preset amount of tension relief.

Disposition: / Status:

Xref (web link) added per SME request.
Please review.

More information and video tutorials can be found at: <https://www.imminet.com/resources/click-tug-snug/>

To disengage the mechanism unbuckle the seat belt and then press the **OFF** button of

the Komfort Latch or tug on the shoulder strap.



Safety Restraint Damage and Repair

Damaged safety restraints in the cab must be replaced. Safety restraints that have been stretched, cut, or worn out may not protect you in an accident. If any safety restraint is not working properly, see an Authorized Service Center for repair or replacement.

For further information on safety restraint and safety restraint maintenance, see [Safety Restraint System - Inspection](#) on page 232.

1

Vehicle Loading

WARNING

DO NOT exceed the specified load rating. Overloading can result in loss of vehicle control, either by causing component failures or by affecting vehicle handling. Exceeding load ratings can also shorten the service life of the vehicle. Failure to comply may result in death, personal injury, equipment damage, or property damage.

WARNING

An unevenly distributed load or excessive load over one axle can adversely affect the braking and handling of your vehicle, which could result in an accident. Even if your load is under the legal limits, be sure it is distributed evenly. Failure to comply may result in death, personal injury, equipment or property damage.

The Gross Vehicle Weight Rating (GVWR) or the maximum front and rear Gross Axle

Weight Ratings are determined by the components installed from the factory on to the vehicle and their designed specifications. (Axle weight ratings are listed on certification label on the driver's door jamb.)

GVWR Gross Vehicle Weight Rating. This is the MAXIMUM WEIGHT your vehicle is allowed to carry, including the weight of the empty vehicle, loading platform, occupants, fuel, and any load. Never exceed the GVWR of your vehicle.

GCW Gross Combination Weight (GCW). This is the actual combined weight of your vehicle and its load: vehicle, plus trailer(s), plus cargo.

GAWR Gross Axle Weight Rating. This is the total weight that one axle is designed to transmit to the ground. You will find this number listed on the driver's door edge.

Load Distribution Be sure any load you carry is distributed so that no axle has to support more than its GAWR.

Weight Distribution Example

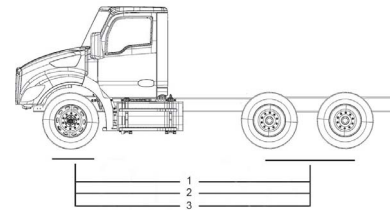

1. Axle Weight
2. Payload Distribution
3. Maximum Load Rating

Front Axle Example

(1)	7,880 lb	(3,574 kg)
(2)	+ 4,120 lb	(1,869 kg)
(3)	= 12,000 lb	(5,443 kg)

Rear Axles Example

(1)		7,540 lb	(3,420 kg)
<hr/>			
(2)	+	24,348 lb	(11,061 kg)
<hr/>			
(3)	=	31,925 lb	(14,481 kg)

Be sure that the load on the vehicle is distributed evenly across each axle so that no axle has to support more than its rated GAWR. In total, the vehicle and its load should not exceed the GAWR for each axle and must not exceed the GCW.

Visual Inspection While Approaching the Vehicle

While approaching the vehicle, inspect the general appearance of the vehicle and its surroundings for any signs of needed attention.

**WARNING**

If equipped with a three-piece roof fairing, DO NOT DRIVE WITH ROOF FAIRING FOLDED DOWN, since the marker lamps will not be effective in that position. Failure to comply may result in death, personal injury, equipment damage, or property damage.

Perform these basic inspection steps before operating the vehicle.

1. Check the overall appearance and condition. Are windows, mirrors, and lights clean and unobstructed?
2. Is the air-intake opening clear of obstructions?
3. Check beneath the vehicle. Are there signs of fuel, oil, or water leaks?
4. Check for damaged, loose, or missing parts. Are there parts showing signs of excessive wear or lack of lubrication? Have a qualified technician examine any questionable items and repair them without delay.
5. Check your load. Is it secured properly?

Daily Checks**NOTE**

These checks are in addition to, not in place of, Federal Motor Carrier Safety Regulations. These regulations may be purchased by writing to: Superintendent of Documents U.S. Government Printing Office Bookstore 710 N. Capitol St. N.W. Washington, DC 20402, or [ContactCenter@gpo.gov](mailto>ContactCenter@gpo.gov).

Engine

- Engine oil
- Engine coolant
- Power steering fluid
- Engine belt
- Fuel filter (water separator) [Fuel System](#) on page 260
- Windshield washer fluid
- Battery cables - check the condition of the battery and alternator cables for signs of chafing or rubbing. Make sure that all clamps (straps) holding the

1

- cables are present and in good working order.
- Hood latch
- Brake lines and hoses
- Steering components - (pitman arm, drag link, tie rod, steering shaft, power steering hoses, etc.).
- Hydraulic clutch fluid
- Brake fluid (trucks with hydraulic brakes)

Chassis and Cab Exterior

- Lights – are any exterior lights cracked or damaged? Perform an Exterior Lights Self Test (ELST) using the dash mounted rotary switch, next to the steering wheel (See *ELST*).

i NOTE
 On certain vehicles equipped with LED technology, tail lights may emit a faint glow when the door is open and the dome light is illuminated.

- Window and mirrors - clean and adjusted?

- Tires, wheels and hubs *Tires* on page 278 *Wheels* on page 281
- Suspension components - check for loose or missing fasteners. Check damage to springs or other suspension parts such as cracks, gouges, distortions, bulges or chafing.
- Brake lines and hoses - check lines, linkages, chambers, parking and service brake operation.
- Air system - *Air System* on page 213
- Steps and grab handles.
- Frame mounted tanks (fuel, diesel exhaust fluid, etc) - check underneath the vehicle for signs of fluid leaks. If any are found, correct before operating the vehicle. Is the tank fill cap secure? Are the tank straps tight? Is the strap webbing in place?
- Trailer connections - are they secure and the lines clear? If they are not being used, are they stored properly? Is the trailer spare wheel secure and inflated? Is the landing gear up and the handle secured?
- Fifth wheel - Is the kingpin or the sliding fifth wheel locked?

Cab Interior

- Seat - adjust the seat for easy reach of controls and visibility.
- Seat belts - fasten and adjust safety restraint belts (which may include restraints in the sleeper).
- Steering column - adjust for easy reach and visibility.
- Mirrors - check and readjust mirrors if necessary.
- Lamps - turn ignition key to the ON position to allow the bulb check and systems check to run. Resolve any issues. Perform an ELST to check the operation of exterior lights.
- Instruments - check all instruments. See *Systems Check* on page 27.
- Windshield - check operation of windshield wipers and washers.
- Horn - check operation of horn.
- Fuel - check vehicle's fuel level. Is there enough fuel?
- Diesel exhaust fluid - check level. Is there enough fluid?
- Air conditioning filters in the cab.

Weekly Checks

NOTE

These checks are in addition to, not in place of, Federal Motor Carrier Safety Regulations. These regulations may be purchased by writing to: Superintendent of Documents U.S. Government Printing Office Bookstore 710 N. Capitol St. N.W. Washington, DC 20402, or ContactCenter@gpo.gov.

Engine

- Belts
- Hoses
- Clamps
- Radiator
- Air filter and its housing
- Engine Aftertreatment system components
- Exhaust pipes
- Engine air pre-cleaner (option) - For vocational vehicles with optional engine air pre-cleaner, check the purge valve at the bottom of the hood mounted

engine air pre-cleaner for any obstructions. Make sure the purge valve will open and close as needed to purge dirt and water from the engine intake air.

Chassis and Cab Exterior

- Battery - check battery and terminals.
- Wheel cap nuts - are they all in place and torqued properly - tighten if necessary. [Wheels](#) on page 281
- Controls and wiring - check for condition and adjustment
- Steering components - check pitman arm, drag link, intermediate shaft U-joint pinch bolt, tie rod, steering shaft and power steering hoses, etc., for loose, broken, or missing parts.
- Cab air conditioner fresh air filter - check for condition and cleanliness.
- PACCAR FX-20 Front Axle Kingpin Joint Grease/Tie Rod Ends (option) (VOCATIONAL USE) - For vocational vehicles with this axle, grease with Heavy-Duty Multipurpose Lithium Based: #1 or

#2 grade, every 50 hours. (Refer to [Front Axle and Suspension](#) on page 263 for maintenance instructions.)

Transmission

- Automatic transmission fluid (where applicable) - Check level, after the engine has warmed up to operating temperature.

Systems Check

Disposition: / Status:
Researching updates to this topic per request.

Systems Check evaluates each monitored system and displays its progress for the operator. The Systems Check can be viewed in the Notifications sub-menu. The Systems Check will also appear when the

SAFETY - Systems Check

1

Exterior Lighting Self-Test (ELST) is activated.

Systems Check Display

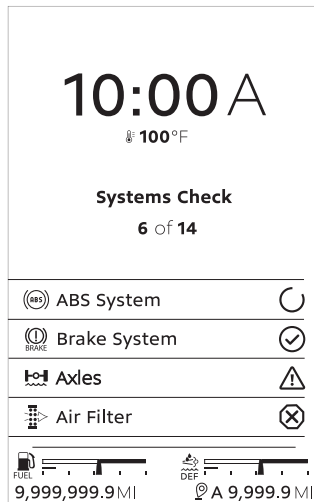

This Systems Check example illustrates the following conditions:

- ABS System – Check in process
- Brake System – Ok (no issues)
- Axles – Non-critical issue
- Air Filter – Critical issue

Other systems may also be checked depending on features installed. Systems Check can be interrupted at any time by:

- Pressing **Select**
- Switching the exterior lights OFF
- Turning the ignition key to OFF or ACC
- Releasing the Parking Brake

Once the Systems Check has completed, the results will display in a summary. A detailed explanation of this summary can be viewed by accessing the Menu after a Systems Check has completed.

2

Chapter 2 | EMERGENCY

Roadside Assistance.....	31
Low Air Actions.....	31
Stop Engine.....	32
Low Oil Pressure.....	32
Service Indicator Turns On.....	32
Engine is Overheating.....	32
How to Inspect and Replace a Fuse.....	34
Where are the Fuses Located?.....	36
How to Jump Start a Battery.....	36
How to Recover a Vehicle.....	38

Roadside Assistance

Call toll-free to talk to someone at the PACCAR Customer Center.



Total Customer Support

1-800-4Peterbilt (1-800-473-8372)

The Customer Call Center is open 24/7-365 days a year and staffed with trained personnel (English and other languages if necessary), free of charge, to provide total roadside assistance. Their custom-mapping system can locate the nearest authorized dealers and Independent Service Providers (ISPs) based on the vehicle's location. In addition, the customer center can dispatch services for jump and pull starts, tires, trailers, fines and permits, chains, towing, hazardous clean-up, out of fuel (roadside), mechanical repairs, and preventive maintenance services. If they cannot answer a specific question, they can direct you to a representative who can.

Low Air Actions

Disposition: / Status:
Altered Topic. Please review before publication.



WARNING

If the air pressure falls below 60 psi (414 kPa), the spring brakes may abruptly stop the vehicle. Monitor air-pressure gauges. If the air-pressure alert is activated, **DO NOT DRIVE** the vehicle until it is serviced. Failure to comply may result in death or personal injury.



NOTE

The instrument cluster gauges may appear (if hidden from view), change brightness and change color to bring attention to a particular system.



2

If either of these warning lights appear, perform the following actions:

1. Slow down carefully.
2. Move a safe distance off the road and stop.
3. Place the transmission in neutral (park with an automatic transmission, if equipped). Set the parking brake.
4. Turn OFF the engine.
5. Turn ON the emergency flasher. Also use other warning devices to alert other motorists if you have them (reflective triangles, portable lights).

If the warning lights appear, or audible alarm sounds, **DO NOT** switch off at start-up. **DO NOT** attempt to drive the vehicle. Contact the nearest authorized dealer to have the problem corrected.

2

Stop Engine



This warning light appears with an audible alarm tone when a major engine system problem exists.

WARNING

If the stop engine warning light turns on, a serious engine system problem has occurred. Safely stop the vehicle and turn OFF the ignition. Do not drive the vehicle until the vehicle has been serviced. Failure to comply may result in death, personal injury, equipment damage or property damage.

Low Oil Pressure



CAUTION

DO NOT operate your vehicle with insufficient oil pressure as this will cause serious engine damage. Failure to comply may result in equipment or property damage.

It is important to maintain oil pressure within acceptable limits. If oil pressure drops below the minimum psi (kPa) the oil pressure gauge will illuminate and change color. Additionally, the Stop Engine Lamp will turn red.

1. Slow down carefully.
2. Move a safe distance off the road and stop.
3. Place the transmission in neutral (park with automatic transmissions, if equipped) and set the parking brake.
4. Turn OFF the engine.
5. Turn ON the emergency flasher and use other warning devices to alert other motorists.
6. Wait a few minutes to allow oil to drain into the engine oil pan, and then check the oil level.

7. Add oil if necessary. If the problem persists, contact an authorized dealer as soon as possible.

Service Indicator Turns On



Vehicle should be serviced to correct the problem, but the situation should not be considered an emergency. The vehicle can still be safely driven.

Engine is Overheating



 **CAUTION**

The cooling system may overheat if the engine coolant is at the minimum level. A sudden loss of coolant, caused by a split hose or broken hose clamp could also lead to an overheat condition. Always inspect to ensure hoses and clamps are not cracked, worn, or loose. Failure to comply may result in equipment or property damage.

 **NOTE**

The system may also temporarily overheat during severe operating conditions such as:

- Climbing a hill on a hot day
- Stopping after high-speed/high-load driving
- Debris blocking air flow through the cooling module (radiator)

If the engine coolant temperature warning lamp comes on and the audible alarm sounds indicating an overheat condition, or if you have any other reason to suspect the

engine may be overheating, DO NOT TURN OFF THE ENGINE unless a low water warning device indicates a loss of coolant.

Follow these steps if the engine coolant temperature is rising, or the temperature is already above normal, and there are no other warning alarms displayed in the instrument cluster.

1. Reduce engine speed, or stop. When stopped, place the transmission in neutral (N) and set the parking brake. Keep the engine running.

 **WARNING**

To reduce the chance of personal injury, vehicle damage and/or death from overheated engines, which can result in a fire, never leave the engine idling without an alert driver present. If the engine should overheat, as indicated by the engine coolant temperature light, immediate action is required to correct the condition. Continued unattended operation of the engine, even for a short time, may result in serious engine damage or a fire. Failure to

comply may result in death, personal injury, equipment or property damage.

 **WARNING**

Removing the fill cap on a hot engine can cause scalding coolant to spray out and burn you badly. If the engine has been in operation within the previous 30 minutes, be very careful in removing the fill cap. Protect face, hands, and arms against escaping fluid and steam by covering the cap with a large, thick rag. DO NOT try to remove it until the surge tank cools down or if you see any steam or coolant escaping. Always remove the cap very slowly and carefully. Be ready to back off if any steam or coolant begins to escape. Failure to comply may result in death, personal injury, equipment or property damage.

Disposition: / Status:
 Step 3 "(if equipped)" added since the Engine Fan Switch is optional. Please review before publication.

2

 NOTE

Keep the engine running at idle speed unless a warning icon turns on that requires the engine to be shut off.

2. Check to ensure the Oil Pressure Gauge reads normal.
3. Make sure the engine fan is turning by switching the **Engine Fan Switch** (if equipped) from AUTO to MAN (Manual).
4. Idle the engine to see if this reduces the coolant temperature. If the temperature does not begin to drop, shut off the engine and contact your nearest authorized dealer.
5. If the temperature begins to return to normal, allow the engine to idle 3 to 5 minutes before shutting it off. This allows the engine to cool gradually and uniformly.
6. If overheating came from severe operating conditions, the temperature should have cooled by this time. If it has not, stop the engine and let it cool before checking to see if the coolant is low.

7. Be sure the vehicle is parked on level ground or the readings may be incorrect. Check the coolant level at the coolant surge tank.

Check the coolant level after each trip when the engine has cooled. The coolant level should be visible within the surge tank. Add coolant if necessary.

How to Inspect and Replace a Fuse

Turn the ignition off and turn all lights off. Locate the fuses in either the cab, sleeper, or main power fuse box. All the electrical circuits have fuses to protect them from a short circuit or overload. If an electrical component on your chassis stops working, the first thing you should check for is a blown fuse.

 WARNING

DO NOT replace a fuse with a fuse of a higher rating. Doing so may damage the electrical system and cause a fire. Failure to comply may result in property damage, personal injury, or death.

 WARNING

Disposition: / Status:
Altered Warning. Please review before Publication.

Never patch fuses with aluminum foil or wire. This may cause serious damage elsewhere in the electrical circuit, and it may cause a fire. Failure to comply may result in death, personal injury, equipment damage, or property damage.

 CAUTION

If a circuit keeps blowing fuses, have the electrical system inspected for a short circuit or overload by an authorized dealer as soon as possible. Failure to do so could cause serious damage to the electrical system and/or vehicle.

CAUTION

Before replacing a fuse, turn OFF all lights and accessories and remove the ignition key to avoid damaging the electrical system. Failure to comply may result in equipment or property damage.

1. Turn off all lights and accessories and remove the ignition key to avoid damaging the electrical system.
2. Determine from the chart on the fuse panel which fuse controls that component.
 - If the circuit has a fuse, remove that fuse and see if it is blown.
 - If the circuit has a polyswitch, have your electrical system inspected by an authorized dealer.

Blown Fuse

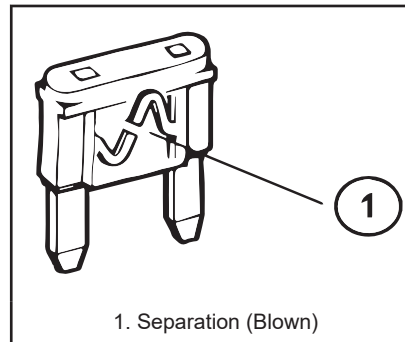

3. If it is blown, replace it with a fuse of the same rating. If a fuse of the same rating is not available, a fuse of a lower rating may be temporarily substituted. You can also use a fuse from a circuit you can do temporarily without (for example an accessory circuit or radio).

CAUTION

When replacing a failed polyswitch (circuit breaker), always use an approved polyswitch (circuit breaker) with a current rating equal to or less than the polyswitch (circuit breaker) being replaced. Only use the approved Type II modified reset polyswitch (circuit breaker). NEVER use a Type I (automatic reset) or Type III (manual reset) polyswitch (circuit breaker). A fuse with a current rating equal to or less than the polyswitch (circuit breaker) being replaced can also be used.

CAUTION

Always close and latch the engine compartment fuse box cover. A latched cover ensures a watertight seal which can prevent damage to electrical components. Failure to comply may result in equipment or property damage.

2

Where are the Fuses Located?

Fuses for the cab are located in the fuse panel behind the drivers side kick panel.

Disposition: / Status:
New graphic. Please review.

Fuse Panel Access

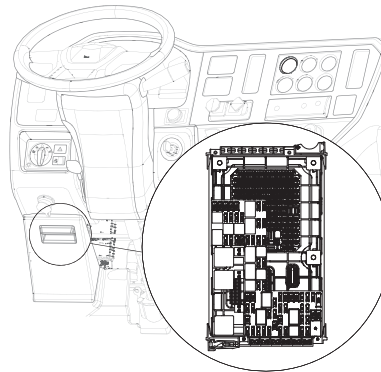

Main power relays are located on the power distribution center, in the engine compartment, mounted to the front wall of the cab.

How to Jump Start a Battery

Jump starting a vehicle is not a recommended practice due to the various battery installations and electrical options. However, if the vehicle battery is discharged (dead), the vehicle may be jump started (using energy from a good battery in another vehicle).



WARNING

Batteries contain acid that can burn and gases that can explode. Ignoring safety procedures may result in death, personal injury, equipment or property damage.

WARNING

Never jump start a battery near fire, flames, or electrical sparks. Batteries generate explosive gases that could explode. Keep sparks, flames, and lighted cigarettes away from batteries. Failure to comply may result in death, personal injury, equipment damage, and property damage.

WARNING

Never remove or tamper with battery caps. Ignoring this could allow battery acid to contact eyes, skin, fabrics, or painted surfaces. Failure to comply may result in property damage, personal injury, or death.

WARNING

To avoid short circuits and damage to yourself or the vehicle, never place metal tools or jumper cables on the battery or nearby. Metal that accidentally comes in contact with the positive

battery terminal or any other metal on the vehicle (that's in contact with the positive terminal), could cause a short circuit or an explosion.

WARNING

Always wear eye protection, remove metal jewelry and avoid leaning over the battery.

WARNING

When jump starting using a battery charger/booster, verify that the battery charger/booster is set to the same jump start voltage and amperage specifications as the vehicle electrical system and batteries (i.e., if the vehicle electrical system is a 12 volt system, the jump start voltage on the battery charger/booster shall be set at no higher than a 12 volt setting). Failure to comply may cause an explosion and/or fire resulting in death, personal injury, and/or equipment or property damage.

WARNING

Heed all warnings and instructions of the jumper cable manufacturer. Failure to comply may result in death, personal injury, equipment or property damage.

CAUTION

Applying a higher voltage booster battery will cause expensive damage to sensitive electronic components, such as relays and the radio. Failure to comply may result in equipment damage.

CAUTION

Improper hook-up of jumper cables or not following these procedures can damage the alternator or cause serious damage to both vehicles.

1. Remove any jewelry that may come in contact with the battery terminals.

2

2. Select a jumper cable that is long enough to attach to both vehicles in a way that ensures neither vehicle touches each other.
3. Position the two vehicles together, but do not allow them to touch.
4. Turn OFF all lights, heater, radio, and any other accessory on both vehicles.
5. Set the parking brake.
6. Shift the transmission into park position or neutral for manual transmissions.
7. If either vehicle is equipped with battery disconnects ensure they are in the OFF position prior to connecting the two vehicles.
8. Attach one end of a jumper cable to the positive (+) terminal of the discharged (dead) battery. This will have a large red + or P on the battery case, post, or clamp.
9. Attach the other end of the same cable to the positive (+) terminal of the good (booster) battery.
10. Attach the remaining jumper cable FIRST to the negative (-) terminal (black or N) of the good battery.

11. Attach the other end of the negative cable to a bare metal part not bolted to the engine block.



NOTE

Always connect positive (+) to positive (+) and negative (-) to negative (-).

12. If either vehicle is equipped with battery disconnects, ensure that they are in the ON position.
13. Start the vehicle that has the good battery first. Let it run for 5 minutes.
14. Start the vehicle that has the discharged (dead) battery.

The engine should start. If the engine fails to start, do not continue to crank the starter. Instead, contact the nearest authorized dealer.



WARNING

When disconnecting jumper cables, make sure they do not get caught in any moving parts in the engine compartment. Failure to comply may result in death, personal injury, equipment or property damage.

Reverse the above procedure exactly when removing the jumper cables. With engine running, disconnect jumper cables from both vehicles in the exact reverse order, making sure to first remove the negative cable from the vehicle with the discharged battery.

How to Recover a Vehicle



CAUTION

Remove the drive axle shafts or lift the driving wheels off the ground before towing the vehicle. Towing the vehicle with either the wheels on the ground or the axle shafts in the axles will cause damage to the axle gears.

**CAUTION**

If your vehicle has a Meritor axle with a driver-controlled main differential lock, install the caging bolt before removing the axles for towing. Installing the caging bolt prevents damage by locking internal axle components in position.

**CAUTION**

Connect recovery rigging only to hitches intended for that purpose. **DO NOT** attach to bumpers or brackets. Use only equipment designed for this purpose. Failure to comply may result in equipment damage.

**WARNING**

Before towing a vehicle, test your air brakes to ensure that you have properly connected and inspected the recovery vehicle's brake system. Failure to do so could lead to a loss of vehicle

control which may result in an accident involving death or personal injury.

All lubricating and clutch application oil pressure is provided by an engine-driven pump, which will not work when the engine is stopped. You could seriously damage your vehicle by towing it with the driveline connected and the drive wheels on the ground. When vehicles are towed, either by wrecker or piggyback, the lubricant in the top front of the drive axle will drain to the rear and will leave the top components dry. The resulting friction may damage them. Always remove the main drive axle shafts before towing your vehicle.

1. Review and understand all the cautions and warnings of this section.
2. Disconnect the drive axle shafts and cover the open hubs. This is necessary because no lubricant will reach the gears and bearings if the transmission is driven by the driveshaft (rear wheels on the ground), causing damage to the transmission.

See [Preparing the Axles for Towing](#) on page 42.

3. Connect the towing chain or cable using best recovery practices.

See [Best Practices for Recovery Rigging](#) on page 44.

4. Make sure the recovered vehicle's parking brake is released.

See [Manually Release the Parking Brake](#) on page 40.

5. If you desire to use the recovered vehicle's brake, ensure that the vehicle's air system is connected to that of the recovery vehicle. Ensure that any air line that has been removed from a driver-controlled main differential lock is firmly capped to prevent loss of air pressure from the recovery vehicle if it is supplying air pressure. If you don't desire to use the recovered vehicle's brake, ensure that you cage the spring brakes before attempting to move the vehicle.

See [Manually Locking a Differential](#) on page 43.

6. Follow state/provincial and local laws that apply to vehicles in tow.
7. Do not tow vehicles at speeds in excess of 55 mph (90 km/h).

2

For additional information concerning heavy duty truck recovery, refer to the following Technology & Maintenance Council (TMC) literature.

- Recommended Practice #602-A — “Front Towing Devices For Trucks and Tractors”
- Recommended Practice #602-B — “Recovery Attachment Points For Trucks, Tractors, and Combination Vehicles”
- Recommended Practice #626 — “Heavy Duty Truck Towing Procedures”

Copies of this literature can be obtained from the following address: Technology & Maintenance Council 950 N. Glebe Road Arlington, VA 22203 Phone: (703) 838-1763 Email: tmc@trucking.org Website: https://tmc.trucking.org/

Manually Release the Parking Brake

Disposition: / Status:
Researching updates to this topic per request.

There may be times when there is not enough air pressure, or the engine’s air compressor is not able to produce enough pressure to release the parking brake. In

such cases, the parking brake (or Spring Brake) can be manually released.

 **WARNING**

DO NOT drive vehicle with malfunctioning brakes. If one of the brake circuits becomes inoperative, braking distances will increase substantially and handling characteristics while braking will be affected. You could lose control of your vehicle or cause an accident. Have it towed to the nearest dealer or qualified repair facility for repair. Failure to comply may result in death, personal injury, equipment damage, or property damage.

 **WARNING**

DO NOT operate a vehicle when the spring brakes have been manually released. Driving a vehicle after its spring brakes are manually released is extremely dangerous. The brakes may not function. Failure to comply may result in death, personal injury, equipment or property damage.

 **WARNING**

DO NOT disassemble a spring brake chamber. These chambers contain a powerful spring that is compressed. Sudden release of this spring may result in death or personal injury.

 **WARNING**

Releasing the spring brakes on an unsecured vehicle could lead to an accident. The vehicle could roll, which may result in death, personal injury, equipment or property damage. Always secure the vehicle with wheel chocks, chains, or other safe means to prevent rolling before manually releasing the spring brakes.

To move a vehicle immobilized by the spring brakes due to loss of air pressure in the brake system, perform the following procedure:

1. Remove the cap from the spring chamber.

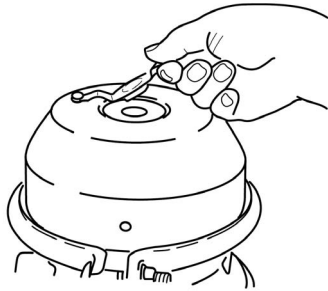

- Remove the release stud assembly from the side pocket, and remove the release nut and washer from the release stud.

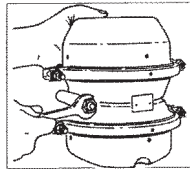

- Slide out the release stud.

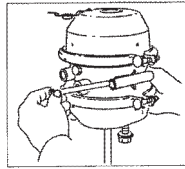

- Insert the release stud through the opening in the spring chamber where the cap was removed. Insert it into the pressure plate. Turn the release stud 1/4 turn clockwise in the pressure plate. This secures the cross pin into the cross pin area of the pressure plate and locks it into the manual release position.

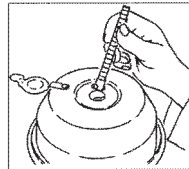

- Assemble the release stud washer and nut on the release stud.

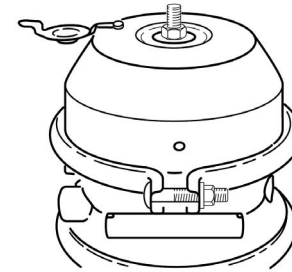

- With a wrench, turn the release stud assembly nut until the compression spring is 90-95 percent caged. While doing this, make sure that the pushrod (adapter pushrod, or service pushrod) is retracting. DO NOT over-torque the release stud assembly. (S-cam-type maximum: 50 lb-ft (68 N·m), Wedge-type maximum: 30 lb-ft (41 N·m)). The spring brake is now mechanically released.

2

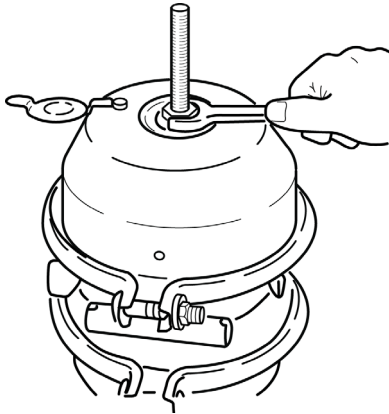

Preparing the Axles for Towing

If the vehicle is going to be towed from the front axle and using the rear axle for support, then the axle shafts should be prepared so that minimal damage is made to the differential during the towing process.

Ensure that the recovered vehicle does not have an open air line. An open air line on the recovered vehicle will cause a leak in the air system of the recovery vehicle if both vehicles' brake systems are connected. This could cause a loss of

system air, which can cause the service brakes not to function, resulting in the sudden application of the spring brakes causing wheel lock-up, loss of control, or overtake by following vehicles.

WARNING

An open air line on the recovered vehicle will cause a leak in the air system of the recovery vehicle if both vehicles' brake systems are connected. This could cause a loss of system air, which can cause the service brakes not to function, resulting in the sudden application of the spring brakes causing wheel lock-up, loss of control, or overtake by following vehicles. You could be in an accident involving personal injury or death. Ensure that any air line that has been removed from a driver-controlled main differential lock is firmly capped to prevent loss of air pressure from the recovery vehicle if it is supplying air pressure.

1. Lift driving wheels off the ground or remove the driveline and axle shafts before towing the vehicle.

CAUTION

Failure to lift the driving wheels off the ground or remove the driveline and axle shafts before towing the vehicle could seriously damage your vehicle. All lubricating and clutch application oil pressure is provided by an engine-driven pump, which does not work when the engine is stopped. When vehicles are towed either by wrecker or piggyback, lubricant in the top front of the drive axle will drain to the rear. This will leave the top components dry, resulting in friction that will seriously damage these components.

2. If the vehicle has driver controlled differential lock, then manually lock the differential.
3. Remove drive axle shafts.
4. Cover the open ends of the hubs to prevent dirt and debris from entering the axle.

CAUTION

Water, dirt, and other material can enter an open hub or axle. This can contaminate the axle fluid and cause possible damage to components. Ensure that the hubs are covered with plastic whenever a drive axle shaft is removed.

Manually Locking a Differential

Follow these procedures if the vehicle has a driver controlled differential lock.

Always lock the differential when the axles are being removed to aid in re-installation. This procedure should be done before the axle shafts are removed.

CAUTION

Failure to install the caging bolt when towing vehicles with driver-control main differential lock can result in damage by failing to lock internal components in position.

WARNING

An open air line on the recovered vehicle will cause a leak in the air system of the recovery vehicle if both vehicles' brake systems are connected. This could cause a loss of system air, which can cause the service brakes not to function, resulting in the sudden application of the spring brakes causing wheel lock-up, loss of control, or overtake by following vehicles. You could be in an accident involving personal injury or death. Ensure that any air line that has been removed from a driver-controlled main differential lock is firmly capped to prevent loss of air pressure from the recovery vehicle if it is supplying air pressure.

CAUTION

A recovered vehicle will have no operational brake system. Additionally, the rear axle spring brakes will probably be applied.

- If you desire to use the recovered vehicle's brakes, ensure that the vehicle's air system is connected to that of the recovery vehicle. Also ensure that any air line that has been removed from a driver-controlled main differential lock is firmly capped to prevent loss of air pressure from the recovery vehicle.
- If you don't want to use the recovered vehicle's brakes, ensure that you cage the spring brakes before attempting to move the vehicle.

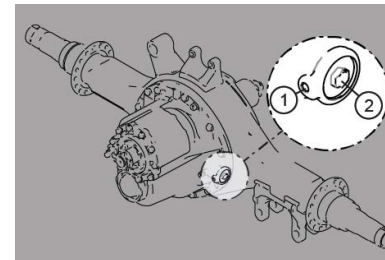

1. Remove the air line and firmly cap the air line from the vehicle. (2)
2. Remove the caging bolt from its storage hole. (1)
3. Screw the caging bolt into the air line hole. (2)

2

2

- When fully engaged, a 0.25-0.5 in. (6.35-12.7 mm) space will remain between the air cylinder and the bolt head. This action will lock the differential by pushing a piston into a "lock" position.

Best Practices for Recovery Rigging

CAUTION

Recovery pull maximums assume the tow rigging evenly distributes the load between both recovery hitches. See examples in Recovery Rigging for details. Serious damage to the vehicle may occur if rigging is not connected properly.

CAUTION

When recovering ditched or bogged vehicles, stay well below maximum capacities. Even at loads below maximum, the physical strain of recovering a vehicle could damage axles, suspensions, fifth wheels, etc.

Recovery Rigging Options

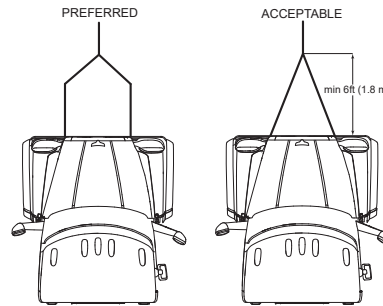

Use a double chain or cable setup that distributes the load equally to both hitches (see either example in Recovery Rigging Options illustration):

- Never loop a single chain or cable through both hitches, also known as reeving (not shown).
- Use a spreader or equalizer bar to distribute the load on both hitches (preferred), or
- If no spreader bar is available, connect the main tow chain or

cable no closer than 6 ft. (1.8 m) from the vehicle: (acceptable).

- Secure the towed vehicle using two additional chains or cables (see *Safety Chains*) (not shown).

Returning to Service After Recovering

Once the vehicle is recovered, the axles must have oil added to prevent gear damage during operation.

- Into the pinion cage, add 1 pt (.47 L) of lubricant or into the interaxle differential, add 2 pt (.94 L) of approved lubricant.
- After adding the specified type and amount of lubricant, drive the vehicle. It must be unloaded. Drive 1 mi to 2 mi (1.5 km to 3 km) at a speed lower than 25 mph (40 km/h). This will thoroughly circulate the lubricant through the assembly.
- If the parking brake is manually released, they must be modified back to their normal operating condition.
- If the differential lock was manually locked, then the caging bolt must be put back in its storage location and the differential lock air line

must be re-installed in its normal position.

Add lubricant back to the axles after recovering the vehicle and before putting it back into service.

What to do if the Vehicle is Stuck in Sand, Mud, Snow, or Ice



WARNING

DO NOT spin the wheels faster than 35 mph (55 km/h). Spinning a tire at speedometer readings faster than 35 mph (55 km/h) can be dangerous. Tires can explode from spinning too fast. Under some conditions, a tire may be spinning at a speed twice that shown on the speedometer. Any resulting tire explosion could cause injury or death to a bystander or passenger, as well as extensive vehicle damage: including tire, transmission, and/or rear axle malfunction.

These suggestions are provided to improve the ability to free a vehicle if the vehicle gets stuck in sand, mud, snow, or ice:

- Move the gearshift lever or selector from first gear to reverse.

- Apply light pressure on the accelerator pedal while the transmission is in gear.
- Remove your foot from the accelerator while shifting.
- Do not race the engine.
- For best traction and safety, avoid spinning the wheels.

Follow these practices to avoid transmission damage:

- Always start vehicle in motion with the shift lever in first gear.
- Be sure that transmission is fully engaged in gear before releasing the clutch pedal (manual only).
- Do not shift into reverse while the vehicle is moving.
- If the vehicle needs to be recovered from being stuck, do not permit the vehicle to be towed for long distances without removing the driveshaft.

If tire chains are needed, make sure they are installed on both sides of the driving axle. Installing chains on only one side of the axle can cause equipment damage.



CAUTION

Chains on the tires of only one tandem axle can damage the driveline U-joints and the inter-axle differential. Repairs could be costly and time-consuming. Failure to comply may result in equipment damage.

2

Towing the Vehicle

A dealer or commercial towing service will have the necessary equipment to safely tow the vehicle and should be able to make arrangements to limit any damage to the vehicle. The towing service and the dealer should be aware of towing regulations and safety precautions.

The towing service will ensure that the following precautions are taken:

- Use of a safety chain system
- Abide by all local towing regulations
- Ensure that the towing device does not contact any surfaces that could be damaged while in transit

EMERGENCY - How to Recover a Vehicle

2

- If towing from the front, ensure that the rear axles are prepared for towing
- If towing from the rear, ensure that all body components such as roof, side, and chassis fairings are secured properly to avoid damage while in transit



WARNING

Secure the roof, side, and chassis fairings while towing from the rear. An unsecured fairing may come off of the vehicle during transit. Failure to secure the fairings while towing may cause an injurious accident resulting in death or personal injury.

Chapter 3 | CONTROLS

3

Instrument Panel.....	49
Instrument Cluster.....	51
Peterbilt Digital Display.....	52
Display Notifications.....	57
Views.....	58
Menu.....	62
Post Trip.....	65
Warning Lights and Indicators.....	65
Steering Wheel Controls (Option).....	80
Dash Switches.....	83
Steering Column Controls.....	104
Door Mounted Mirror Controls.....	110
Introduction.....	112
Heating and Air Conditioning.....	112
Cab Accessories.....	119

Instrument Panel

Disposition: / Status:

Graphic below updated (Instrument Cluster alteration). Please review before publication.

3

CONTROLS - Instrument Panel

3

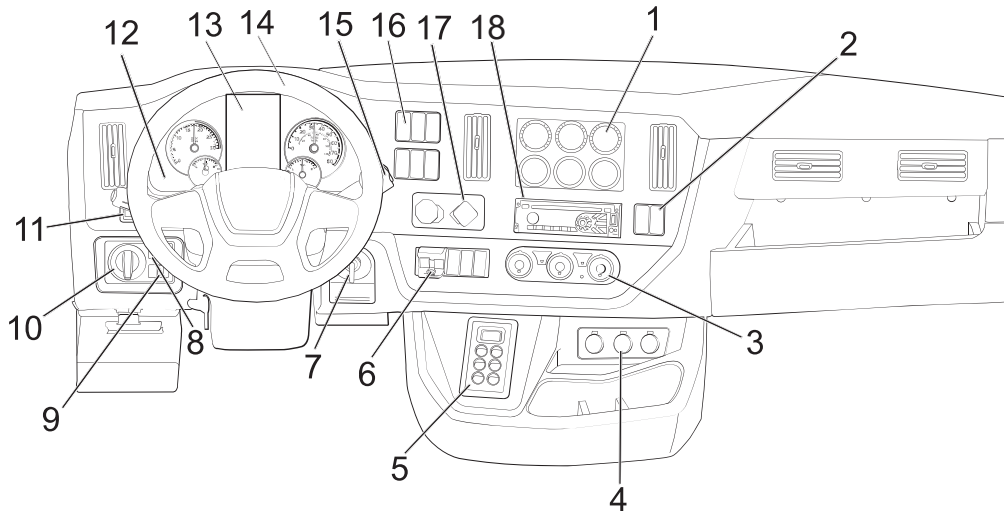

1. Optional Gauges
2. Dash Switches
3. A/C Controls
4. 12 V Outlets
5. Shifter (push button shifter shown)
6. Compact Trailer Valve
7. Ignition
8. Hazard Switch
9. Dimmer Switch
10. Exterior Lights Switch (ELS)
11. Signal Stalk
12. Instrument Cluster
13. *Peterbilt Digital Display*
14. Steering Wheel
15. Column Shifter (option)
16. Dash Switches
17. Parking Brake (air operated)
18. Radio Stereo System

Instrument Cluster

Disposition: / Status:
Graphic, title, and list updated (item 5 added). Please review before publication.

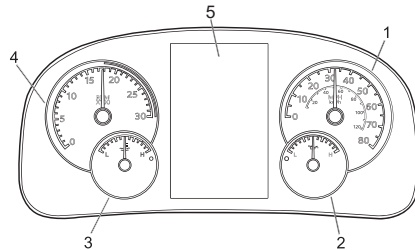

1. Speedometer
2. Engine Oil Pressure
3. Engine Coolant Temperature

4. Tachometer
5. *Peterbilt Digital Display*

Speedometer

The speedometer (1) is located on the right side of the main instrument cluster. A digital speedometer is shown on the digital display (5) while driving. The speedometer indicates the vehicle speed in miles per hour (mph) or in kilometers per hour (KM/h). The scale of mph or KM/h on the speedometer (1) depends on where the vehicle was sold. You can change digital speedometer units on the digital display (5) by updating the "units".

Engine Oil Pressure



CAUTION

DO NOT operate your vehicle with insufficient oil pressure as this will cause serious engine damage. Failure to comply may result in equipment or property damage.

The Engine Oil Pressure gauge monitors the oil pressure to the Engine. It is important to maintain oil pressure within

acceptable limits. If oil pressure drops below the minimum PSI/kPa, the Stop Engine warning light will illuminate, a notification will appear (see [Notifications](#) on page 57), and an audible alarm will sound.

If the oil pressure fails to rise within 10 seconds of starting the engine, stop the engine and determine the cause. Check the engine manufacturer's manual for the correct oil pressure ranges for your vehicle's engine. If the oil pressure suddenly drops, or the audible alarm and engine oil pressure telltale (see [Low Oil Pressure](#) on page 32) come on while driving, safely stop the engine and address the issue. For further information on engine gauges and operating your engine properly, see [Engine Maintenance](#) on page 253.

Engine Coolant Temperature

The Engine Coolant Temperature gauge indicates the temperature of the engine coolant.

If the coolant temperature exceeds the maximum limits, a red warning lamp in the gauge will turn on and an audible warning will sound. If the coolant temperature continues to rise, the Check Engine and/or Stop Engine lights will also come on.

3

 **CAUTION**

This should be considered an emergency. You should stop the vehicle as safely as possible and turn OFF the ignition. The vehicle must be serviced and the problem corrected before driving again. Failure to do so may cause severe transmission damage.

Under normal operating conditions, the water temperature gauge should register between 165° and 205° F (74° and 90° C). Under certain conditions, somewhat higher temperatures may be acceptable. The maximum allowable temperature is 220° F (104° C) with the cooling system pressurized, except for certain engines. Check the engine manual to be sure.

Tachometer

Disposition: / Status:
Description modified. Please review before publication.

Disposition: / Status:
Paragraph revised. Please review.

The tachometer is a useful gauge when attempting to drive efficiently. It will let you match driving speed and gear selection to the operating range of your engine. If the engine speed gets too high, you can select a higher gear to lower the rpm. If the engine speed drops too low, you can select a lower gear to raise the rpm. To avoid engine damage, do not let the pointer exceed maximum governed engine speed. (See your Engine Operation and Maintenance Manual for rpm recommendations.) During optional PTO operations, an additional tachometer view appears on the Digital Display.

Optional Gauges

Optional physical gauges can be located in a separate panel to the right of the main instrument cluster.

Peterbilt Digital Display

Disposition: / Status:

Sentence modified. A new introduction was added. Please review before publication.

The Digital Display is located on the main instrument cluster and shows multiple cards via the menu control switch. The Digital Display is visible during all driving situations and in some parked situations. When the parking brake is set and the truck key is in, the following actions will wake the display, making it visible:

Disposition: / Status:
New bullet added (Using the Menu Control Switch). Please review before publication.

- Tapping the brake
- Opening (or keeping open) the cab doors
- Turning the ignition switch to **ON**, **ACC**, or **START**
- Starting the engine
- Activating exterior lamps (see *Lights, Exterior Lights Switch (ELS)* on page 97)
- Using steering wheel switches²
- Using the Menu Control Switch

² This requires the steering wheel controls option.

If after 20 seconds, none of these actions are taken, the display will darken to conserve power, but will awaken when any wake action is performed. If the Anti-Theft option is active and you attempt to start the engine, a passcode prompt will appear. The engine cannot be started until the correct passcode is entered (see *Anti-Theft* on page 56).

Digital Gauges

Disposition: / Status:
 Researching updates to this topic per request.

Disposition: / Status:
 First sentence modified. Please review before publication.

If a gauge has a red zone (representing a gauge region outside of a component's normal operating range), it is indicated by a horizontal red line. If a gauge that goes into a warning state is not present on the currently shown view, then the gauge shows up in the lower part of the display.



Gauges that enter a red zone will enlarge and turn red. If the gauge value rises into this zone, this boundary will indicate with a white line, if it lowers, it indicates with a red line.



Gauges that stop receiving input from the systems they monitor, will display the text "Data Error" and turn gray, with critical gauges instead, turning red. Gauges displaying "Data Error" will stop presenting values reflecting the systems they monitor.

Vehicle Air Pressure

The Primary Air Pressure gauge indicates pressure in the rear braking system. The Secondary gauge indicates pressure in the front braking system. Each gauge indicates the amount of air pressure in each system in pounds per square inch (psi). On vehicles equipped with metric air pressure gauges, the gauge face plate includes a kPa (major) scale and psi (minor) scale.

WARNING

If the air pressure falls below 60 psi (414 kPa), the spring brakes may abruptly stop the vehicle. Monitor air-

pressure gauges. If the air-pressure alert is activated, DO NOT DRIVE the vehicle until it is serviced. Failure to comply may result in death or personal injury.

WARNING

The air pressure gauge may appear and change color along with an audible alarm tone to indicate a dangerous situation: there is not enough air pressure in the air tanks for repeated braking and the brake system has failed. Without the use of your service brakes your spring brakes could suddenly apply causing a wheel lockup, loss of control, or overtake by following vehicles. This may cause an accident resulting in personal injury or death. Bring the vehicle to a safe stop right away, while you still have control of the vehicle.

3

 **CAUTION**

DO NOT attempt to move the vehicle before air system pressure reaches 100 psi (689 kPa). The wheels may still be locked by the spring brakes, resulting in unnecessary brake wear or damage. Failure to comply may result in equipment damage or property damage.

Fuel Level



In addition to indicating empty and full, the gauge(s) also indicate the fuel level in graduated increments. When the fuel level for the tank is below 1/4 full, a red warning lamp in the gauge will come on.

 **WARNING**

DO NOT carry additional fuel containers in your vehicle. Fuel containers, either full or empty, may leak, explode,

and cause or feed a fire. Failure to comply may result in death or personal injury.

 **WARNING**

Diesel fuel in the presence of an ignition source could cause an explosion. A mixture of gasoline or alcohol with diesel fuel increases this risk of explosion. DO NOT remove a fuel tank cap near an open flame. Use only the fuel and/or additives recommended for your engine. Failure to comply may result in death, personal injury, equipment or property damage.

 **CAUTION**

Disposition: / Status:
 Changed Caution. Please Review. Removed content split into this Caution and two Notes (twa1699548331962.xml) and (xvm1699548525531.xml).

Use only Ultra Low Sulfur Diesel (ULSD) Fuel, as recommended by engine manufacturers. High-sulfur diesel

fuel will damage the aftertreatment system and impact the engine emissions which will result in the engine not meeting emission regulations. Failure to comply may result in equipment or property damage.

 **NOTE**

Disposition: / Status:
 New Note. Please review. Content extracted from existing Caution. NO NEW CONTENT.

For more information on fuel specifications, consult the engine operator's manual.

i NOTE

This vehicle may be manufactured with different fuel systems and different draw tube locations. Because of this and the amount of road crown, it is recommended that you do not operate your vehicle with less than one-quarter of your truck's fuel capacity. Allowing the fuel level to go below one-quarter of capacity could result in the lack of fuel to keep the engine running. In addition, you will want to keep the fuel tanks at least half-full to reduce condensation of moisture in the tanks. This moisture can damage the engine.

Diesel Exhaust Fluid (DEF)

The diesel exhaust fluid gauge shows the approximate amount of DEF fluid in the DEF tank.

DEF Level Gauge



CAUTION

Only use Diesel Exhaust Fluid (DEF). Failure to do so may damage components of the diesel particulate filter (DPF).

Besides empty and full, the gauge also indicates 1/4, 1/2, and 3/4 of total capacity. DEF fluid is required to meet certain emission requirements. A warning icon and notification message will appear when the DEF level is low. Do not allow your DEF tank to remain empty. Please refer to your emission supplemental manual for more details about DEF fluid.

i NOTE

The instrument cluster gauges may appear (if hidden from view), change brightness and change color to bring attention to a particular system.

Digital Display Features

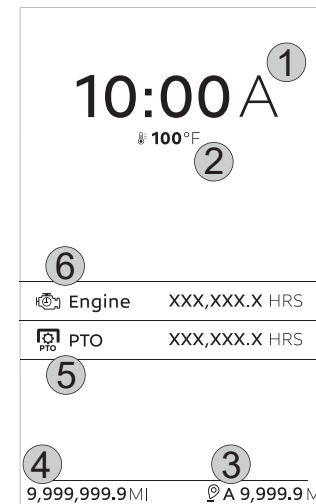

3

3

1. Time
2. Outside Air Temperature (OAT)
3. Trip (Sub-trip)
4. Odometer
5. Power Take-Off (PTO) (option)
6. Engine Hours

Adaptive Cruise Control Notification (option)



Disposition: / Status:
 Change of terminology (truck by vehicle)
 per SME request. Please review.

This indication at vehicle start means it is equipped with Adaptive Cruise Control (ACC) and Collision Mitigation. These features work together to improve driver safety and enhance the driving experience.

When Cruise Control is active, ACC will accelerate and slow the vehicle to maintain a chosen distance from a detected forward vehicle. Collision Mitigation will attempt to prevent a forward collision when advancing at speeds greater than 15 mph (24 kph). Please review the ACC section of this manual, and the manufacturer's manual, prior to driving this vehicle.

Anti-Theft

Anti-Theft prevents starting the engine unless the Anti-Theft passcode is entered.³ If Anti-Theft does not show in the settings sub-menu, see your authorized dealer to install Anti-Theft.

If Anti-Theft is enabled, turning the ignition switch to **START** prompts the operator to enter the passcode. Once the correct passcode is entered, you have five minutes to start the engine or the passcode must be entered again.⁴

To enable or disable Anti-Theft, change Anti-Theft (ON/OFF) in the settings sub-menu, and then enter the current passcode.

³ Anti-Theft also prevents accessing the settings sub-menu.
⁴ Timer can be postponed in one minute intervals using any steering wheel switch.

How to Enter the Passcode

The ignition key and the current passcode are required. The default passcode is set to 0000 at the factory. Please see an authorized dealer if a custom passcode is needed. The operator will not need a passcode to start the engine when the anti-theft feature is turned off.

1. Using the **Scroll**, scroll to the first number in the code then press **Select**.

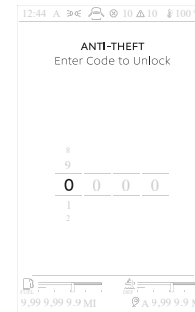

The next digit will be selected.

2. **Scroll** to the number you want for this digit and press **Select**.

- The next digit will be selected.
- Continue this process until all four digits have been chosen.
- The display will read "Turn Key to Start Engine."

Display Notifications

The digital display communicates vehicle information using digital warning lights (also called Telltales), gauge states, notifications, indicators, and audible alarms. Some conditions are communicated for informational purposes only while others may require an operator response.

Notifications

A notification communicates vehicle information. Notifications can be red, amber or white. Red and amber notifications are totaled in the Active Warnings Indicator at the top of the display. Notifications' characteristics (color, brilliance, and whether it flashes or has an

audible alarm) depend on the condition that generated the notification.



- Stack Size – The lower number indicates how many notifications are in the stack (suppressible and non-suppressible), and the upper, which notification is being viewed.
- Title – Notification.
- Suppressibility – Indicates if the current notification is suppressible.⁵
- Instructions – Contains instructions or elaborating information.

When multiple notifications are present, each is assigned a priority and placed in a stack. Higher priority notifications are placed towards the front of the stack. The **Select** button cycles through the active notifications, allowing each notification in the stack to be viewed.

Some notifications, once viewed, are removed from the stack; these notifications are called suppressible. Suppressible notifications show an "X" below the **Select** icon and typically don't require an immediate response. Suppress these notifications using the **Back/Cancel** button (or the **Select** button when the parking brake is set). Non-suppressible notifications cannot be removed from the stack until the parking brake is set.

	NOTE
The menu is not accessible until all notifications have been suppressed. ⁶	

Active Warnings

Red and amber notifications will generate an active warning. Active warnings provide an additional reminder of the new and ongoing conditions which have generated a notification (both suppressed and unsuppressed). An active warnings count is presented in the

⁵ The **Select** icon shown is for vehicles equipped with a Menu Control Switch (MCS); steering wheel switches indicate differently.

⁶ All notifications become suppressible when the parking brake is set.

CONTROLS - Views

3

- Systems Check
- Notifications sub-menu
- Post-trip
- Active Warnings indicator.

The active warnings count may change without user interaction if individual warnings are intermittent, time based, self correcting, or the situation is rectified.

Views

A view presents a specific set of gauges and/or indications on the display. The operator can cycle through the available views using the **Scroll**. When a view is shown, its position in the view sequence is indicated on the right. Some views monitor optional systems, appearing only if those systems are installed and/or active. The menu is also positioned in the view sequence. When the parking brake is set, some views provide additional options and information. Use the **Select** button to access these options. All views present the following indications:

Standard Indications

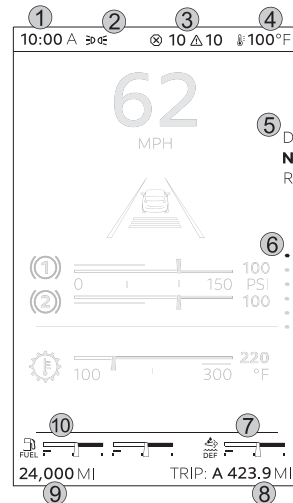

Disposition: / Status:
"Aux Lights" changed to "Headlights" and
"Transmission Gear Display" changed to
"Transmission Mode" per SME feedback.
Please review before publication.

1. Time
2. Headlights
3. Active Warnings (see [Active Warnings](#) on page 57).

4. Outside Air Temperature (OAT)
5. Transmission Mode
6. View Indicator
7. Diesel Exhaust Fluid (DEF) level.
8. Trip Information (see [Trip Info](#) on page 61).
9. Odometer
10. Fuel Gauge

When the parking brake is released, the display will show useful driving information, minimizing the currently selected view.

Gauge Views

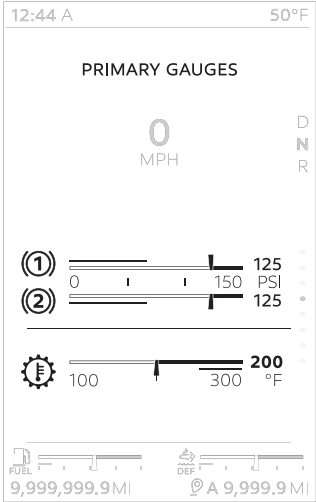

A gauge view presents the standard and optional virtual gauges monitoring your truck systems. Two single or two compound gauges can be shown per view. Gauges not shown in the first gauge view are shown in additional gauge views until all monitored systems are represented:

- Primary Gauges – The highest priority gauges. For vehicles with air brakes this will include the

primary and secondary air tank pressures.

- Secondary Gauges – The second most important gauges.
- Additional Gauges – Any additional gauges not represented by the primary and secondary gauge views.

WARNING

DO NOT look at the Digital Display for prolonged periods while the vehicle is moving. The Digital Display should be referenced only briefly and should not be used as a substitute for observing actual road and traffic conditions. Failure to pay attention to the vehicle's road position or situation can lead to an accident. Failure to comply may result in death, personal injury, equipment damage, or property damage.

Custom Gauge View (option)

Disposition: / Status:
 Topic title changed. Please review before publication.

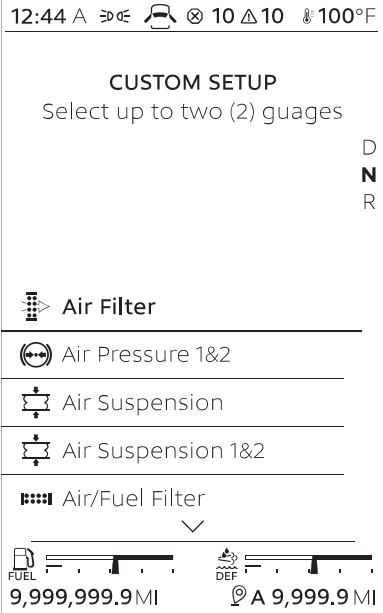

Vehicles with this option provide a view which can contain up to four operator-selected gauges. If the custom view has not been configured, scrolling to the custom view allows the operator to enter the custom view setup (See Custom

3

Setup).⁷ The custom view can also be changed in the menu.

Custom Setup

Disposition: / Status:
Researching possible rewrites.

Creates a customized view containing up to four gauges, and places that view in the view cycle. Once two single gauges or compound gauges have been selected, the remaining gauge selections will fade indicating that no further selections can be made.

1. If the custom view already contains gauges
 - Select **Clear All** to remove those gauges, or
 - Keep the current gauge or compound gauge.
2. **Scroll** to the desired gauge or compound gauge.
3. **Select** to choose that gauge. The gauge name will turn white and a check mark will appear beside the name.



NOTE

A gauge, once selected, can be removed by selecting that gauge again, clearing the check mark.

4. If another gauge or compound gauge is desired, repeat steps 2 and 3.
5. **Scroll to Save Configuration** and press **Select**.

The custom view will now show the selected gauges.

Tire Pressure Monitoring System (option)

Disposition: / Status:
Researching possible rewrites.

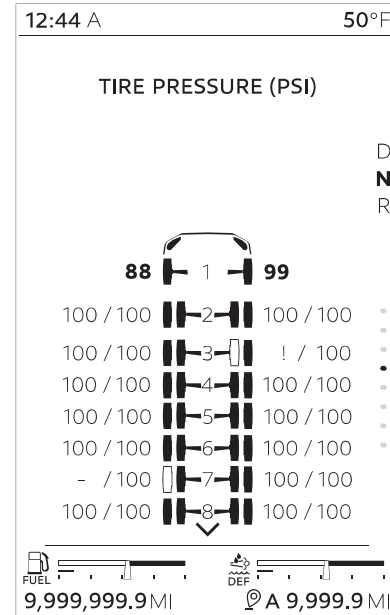

The Tire Pressure Monitoring System (TPMS) is an optional feature combining tire data with the chassis axle layout, displayed graphically. The TPMS can be viewed only while the parking brake is set.

⁷ To change the custom view configuration the parking brake must be set.

TPMS displays individual tire pressures and tire locations, using color to indicate the tire pressure condition:

- Gray – Normal
- Amber – Low (generates a notification)
- Red – Very Low (generates a notification)
- White – High (generates a notification)

A Tire High Temperature condition also generates a notification.

Trip Info

Disposition: / Status:
Researching possible rewrites.

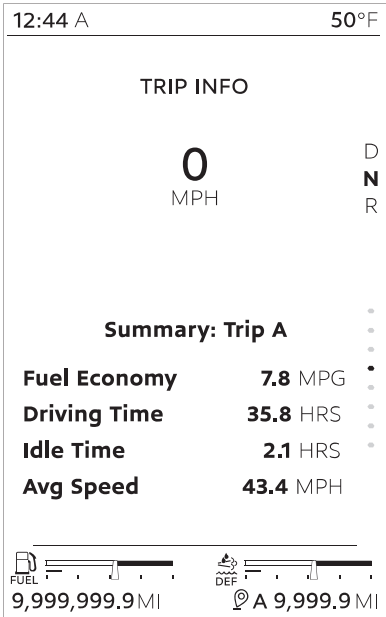

Presents information concerning truck use during the current trip. These details will be collected until the trip is reset, or the max trip distance (99,999.9 miles for main, 9,999.9 for sub-trips) is reached. For detailed trip information see Trip Summary located in the menu.

Adaptive Cruise (option)

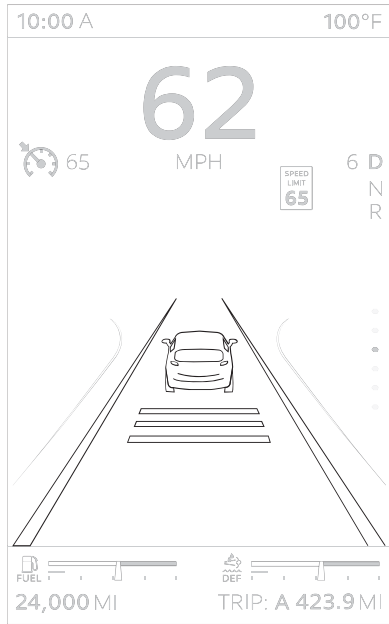

Disposition: / Status:
Researching possible rewrites.

The Adaptive Cruise view contains optional features designed to improve the driving experience:

CONTROLS - Menu

3

- Adaptive Cruise Control (ACC) – see [Adaptive Cruise Control](#)
- Lane Departure Warning (LDW) – see [Lane Departure Warning \(Option\)](#) on page 139

PTO (option)

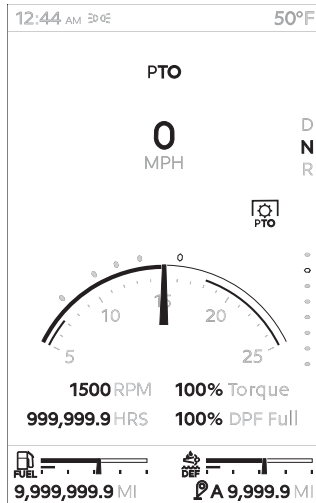

This truck may be equipped with Power Take-Off (PTO). PTO operation is enabled by using the dash mounted PTO switch in conjunction with the Cruise Control controls. For information on PTO operation, see [PTO Operations \(option\)](#) on page 133.

Menu

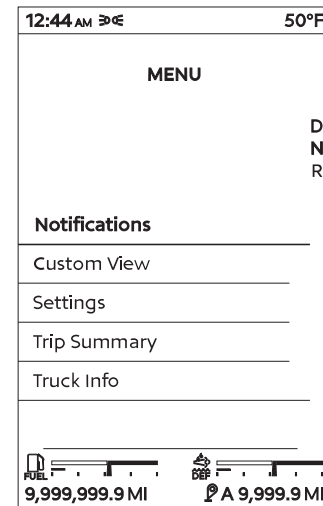

The menu allows the operator to view active warnings, truck performance, activate and customize vehicle features, and access trip information. The menu can only be accessed when the parking brake is set.⁸ Use the **Scroll** to choose the menu

⁸ All notifications become suppressible when the parking brake is set.

view and then press **Select** to access the menu. The menu contains sub-menus:

- Notifications – Shows active warnings and components monitored by a systems check.
- Custom View – Configures the custom gauge view:
 - Custom View ON/OFF – Enables the custom view.
 - Edit – Changes the gauges shown in the custom view (see [Custom Setup](#) on page 60).
 - Reset – Returns custom view to its default configuration.
- Settings – Customizes the display and enables functionality (see [Settings](#) on page 63).
- Trip Info – Shows information concerning truck use between trips (see [Trip Summary](#) on page 63).
- Truck Info – Truck information stores data about the vehicle (see [Truck Information](#) on page 64).

First sentence modified, per SME feedback. Please review before publication.

Trip Summary is the location to view accumulated truck usage data. This information is collected into the total trip (called the Full Trip) and optionally, several sub-trips (each identified with a letter). Trip Summary collects and totals data until the **Trip** has been reset or the max total distance is reached, at which point no further trip information will be added. The max total distance for the main trip is 99,999.9 and 9,999.9 for a sub-trip. Each trip can be scrolled to and selected by turning the **Scroll** and then pressing **Select**.

Each trip contains the following categories:

- Distance – Shows the distance traveled during the sub-trip or the total distance traveled during all trips.
- Trip Info – Shows information about fuel use, trip time, cruise control usage, and engine load.

- Time Stamp – Shows the start and stop times, and the dates for the selected trip.
- Idle – Shows the fuel usage and time spent when idling.
- PTO (option) – Shows information about PTO specific usage during the trip.

The information contained in these categories can be viewed by scrolling within that specific trip sub-menu.

Settings

Settings allows the operator to customize the display:⁹ Selections are made by navigating to the desired setting with the **Scroll** and pressing **Select** to change the setting. Press **Back/Cancel** to return to the previous menu.

Date & Time

- Format – Changes the clock to a 12-hour or 24-hour format.
- Automatic Time (option) – When active, automatically sets time and date based on location.
- Set Time – Sets the clock.¹⁰

Trip Summary

Disposition: / Status:

⁹ If Anti-Theft is enabled, settings will not be accessible until the correct passcode is entered.

¹⁰ Not available if automatic time is active.

CONTROLS - Menu

3

- Set Date – Sets the date.¹¹



Units & Language

- Unit Standard/Metric – Changes the numerical readout to Standard, Metric or Metric with PSI units.
- Language – Changes the language to English, Spanish, or French.

Features

- Anti-Theft – Turns Anti-Theft On/Off (see [Anti-Theft](#) on page 56).
- Dark Cabin – Turns Dark Cabin On/Off; this prevents cab interior lights from turning on when a cab door is opened.
- Trailer Detect – Turns Trailer Detect On/Off .
- LVD Setup – Sets the Low Voltage Disconnect setting (see [Low Voltage Disconnect \(LVD\) \(option\)](#) on page 243).

Truck Information

12:44 AM ☼	50°F
MENU TRUCK INFO	
	D N R
Chassis	
Engine	
ABS	
Transmission	
Cruise Control	
GHG Vehicle Speed	
 FUEL  DEP	
9,999,999.9 MI	PA 9,999.9 MI

Truck Information stores specifications and data about the vehicle:

- Chassis
- Engine
- ABS
- Transmission (option)
- Adaptive Cruise (option)

- Predictive Cruise (PACCAR Engines Only)
- GHG Speed Limiter (option)
- Tire Pressure Monitor (option)
- Digital Vision System (option)
- Lane Departure Warning (option)
- Lane Change Assist (option)
- Lane Keeping Assist (option)
- Other Software
- PTO (option)

Detailed information for listed components or features can be shown by scrolling (using the **Scroll**) to the item and then pressing **Select**.

¹¹ Not available if automatic time is active.

Post Trip

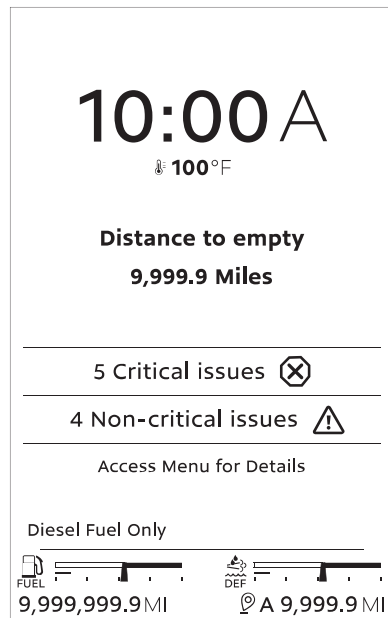

Post Trip presents information the driver might require for the next time the vehicle is operated, such as active warnings and

the distance to empty. Post trip is shown when the ignition switch is turned to OFF. During Post Trip, the menu can be accessed by pressing **Select**.

Warning Lights and Indicators

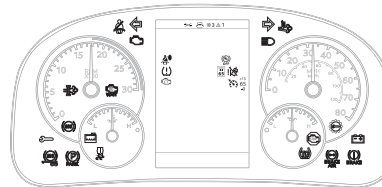

The instrument panel communicates many vehicle conditions using warning lights (also called telltales), indicators, and audible alarms and tones. Alarms and tones are sometimes accompanied by an indicator or warning light. Some indications are communicated for informational purposes only – indicators – while warning lights often require an operator response and are frequently accompanied with a notification (see *Notifications* on page 57). Warning lights, indicators, and audible alarms and tones may indicate a system malfunction or attempt to draw attention to

the component it monitors, so they should be checked frequently and responded to promptly. These indications could save you from a serious accident.

Some of these indications also present an associated notification, providing additional information (see *Notifications* on page 57). Red and amber notifications are tallied at the top of the display and can be viewed in the notifications sub-menu when the parking brake is set. Additionally, gauges may become visible on the Digital Display and may change color or brightness to bring the gauge to the operator's attention.



WARNING

Do not ignore any type of tone or lights. These signals tell you that something is malfunctioning on your vehicle and provide you an indication of what system is affected. It could be a failure of an important system, such as the brakes, which could lead to an accident. Failure to comply may result in death, personal injury, equipment damage, or property damage.

Some warnings can be managed by the operator while others may require an authorized dealer repair. The following

CONTROLS - Warning Lights and Indicators



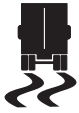

table lists the warning lights and indicators that appear on the instrument cluster. Each indication in this table has a unique name,







symbol, and lists the illuminated color or colors. The table also lists whether the indication is standard (Std) or optional

(Opt). Optional indications require the vehicle to have a specific component installed.

Indicators







3

Title	Symbol	Color	Std	Opt
<i>Antilock Brake System (ABS)</i> on page 70		Amber	•	
<i>Anti-Lock Brake System (ABS), Trailer</i> on page 71		Amber	•	
<i>Battery Telltale</i> on page 73		Red	•	
<i>Stability Control (Option)</i> on page 72		Amber	•	
<i>Traction Control</i> on page 73		Amber	•	





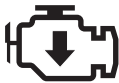

Title	Symbol	Color	Std	Opt
<i>Brake System Malfunction</i> on page 73		Red	•	
<i>Transmission, Failure</i> on page 79		Red		•
<i>Diesel Particulate Filter (DPF)</i> on page 74		Amber	•	
<i>Engine BrakeSaver or Transmission Retarder</i> on page 75		Amber		•
<i>Engine, Check Engine</i> on page 75		Amber	•	
<i>Engine Brake Indicator</i> on page 156		Green		•

CONTROLS - Warning Lights and Indicators

3





Title	Symbol	Color	Std	Opt
<i>Engine, Low Coolant Level</i> on page 76		Amber	•	
<i>Engine, Overspeed</i> on page 76		Red	•	
<i>Stop Engine</i> on page 32		Red	•	
<i>Engine Wait-to-Start Light</i> on page 76		Amber		•
<i>Fast Idle Control</i> on page 77		White/Green		•
<i>Emissions, High Exhaust System Temperature</i> on page 77		Amber	•	
<i>Emissions, Engine Derate</i> on page 77		Amber	•	

CONTROLS - Warning Lights and Indicators

Title	Symbol	Color	Std	Opt
<i>Hill Start Aid (HSA) Disabled Warning Light (option)</i> on page 78		Amber		•
<i>Lane Departure Warning (LDW)</i> on page 78		Amber		•
<i>Lights, High Beam</i> on page 78		Blue	•	
<i>Malfunction Indicator Lamp (MIL)</i> on page 78		Amber	•	
<i>Park Brake</i> on page 79		Red	•	
<i>Seat Belt, Fasten</i> on page 79		Red	•	
<i>Transmission, Service</i> on page 79		Amber		•

CONTROLS - Warning Lights and Indicators

3

Title	Symbol	Color	Std	Opt
<i>Transmission, Failure</i> on page 79		Red		•
<i>Transmission, Oil Temperature High</i> on page 79		Amber		•
<i>Turn Signal, Left</i> on page 80		Green	•	
<i>Turn Signal, Right</i> on page 80		Green	•	

Antilock Brake System (ABS)



Illuminates during the Bulb Check (see [Bulb Check](#) on page 129). Have the ABS checked by an authorized dealer if the ABS warning lamp stays on for more than 3 s?

- Illuminates during normal operating conditions to indicate a problem with the ABS.
- Illuminates when a problem exists with Automatic Traction Control (ATC).

See also Automatic Traction Control on page 4-33.

i NOTE

After servicing the ABS, the lamp stays on after the power-on self-test. This indicates that the ABS wheel sensors have not been checked by the ABS. As soon as the vehicle is driven at speeds above 4 mph (6 km/h) the lamp turns off, indicating that the wheel sensors have been checked by the ABS.

turned ON, regardless of whether you have Trailer ABS. When the bulb self-test detects functioning Trailer ABS, the lamp turns off.

⚠ CAUTION

If the ABS warning light does not illuminate when the ignition is first turned on, there is a problem with the bulb or wiring. Have this inspected as soon as possible. Failure to comply may result in property or equipment damage.

a system problem. This should be **checked by an authorized dealer** as soon as possible. Power on self-test for the *trailer* ABS is controlled by the cluster and occurs under *all* conditions.

i NOTE

If the Trailer ABS Warning Lamp does switch on during the power-on self-test, there may be a problem with the light or wiring. You should have this checked as soon as possible.

3

**Anti-Lock Brake System (ABS),
Trailer**



1. The ABS, Trailer indicator illuminates during the power-on self-test when the ignition is turned ON. It turns off after a few seconds if no system problems are detected. The bulb self-test is performed whenever the ignition is

If the ABS warning light turns on at any other time, it is indicating that a problem exists with the Power Line Communication (PLC) trailer ABS. This should be checked by an authorized dealer as soon as possible. (Refer to "Trailer ABS" in the Operator's Manual for more information.)

3. If your tractor and trailer have the, "Special Trailer ABS (Without PLC) Option," refer to "Special Trailer ABS (Without PLC) Option" in the Operator's Manual. This lamp will switch on when the trailer ABS has

3

i NOTE

Disposition: / Status:
Indicator color updated from yellow to amber. Please review.

Tractors/Trucks and trailers built after 03/01/2001 must be able to turn on an In-Cab Trailer ABS Warning Light (per U.S. FMVSS121). The industry chose Power Line Communication (PLC) as the standard method to turn it on. On trailers built prior to 03/01/2001, verify trailer ABS system status via the required external warning light mounted on the trailer. The indicator light on the trailer should be amber and identified with the letters ABS.

i NOTE

The Trailer ABS Warning Lamp will not turn on when connected to trailers with ABS (but without PLC) powered through the primary 7-way trailer light line. Use the lamp on the driver's side of the trailer to identify trailer ABS problems.

i NOTE

For doubles or triples, the lamp does not distinguish between trailers. An ABS problem in any of the trailers will activate the Trailer ABS Warning Lamp.

Stability Control (Option)



Calculates the driver's intended path of travel from wheel speed and steering angle sensors, then compares calculations to the actual direction of travel. The system uses individual wheel brakes to re-adjust the path of the vehicle.

- The Stability Control Icon (ESC or Electronic Stability Control) illuminates during the Bulb Check when the ignition is switched ON. The lamp switches off after a few seconds if no system problems are detected. If a problem is detected,

- the ESC Warning Lamp will switch on and stay on.
- Illuminates when the ESC system is regulating individual wheel brakes to correct the vehicle's direction of travel. (Refer to Advanced ABS with Stability Control for more information.)

! WARNING

If this chassis is equipped with an Electronic Stability Control (ESC) and is modified (e.g. adding or removing an axle, converting from a truck to a tractor, converting from a tractor to a truck, changing the body, lengthening of the wheelbase and/or frame, relocating frame components, or modifying pneumatic or electrical ABS/ESC harnesses) the ESC must be evaluated by a qualified technician. If you have any questions, contact your authorized dealer. Failure to comply may result in death, personal injury, equipment damage, or property damage.

i NOTE

For more information about the stability control system installed on your vehicle, please refer to additional material supplied with this operator manual, included in your glove box informational packet.

- continues, the ATC warning light will switch on, and stay on.
- Illuminates when the ATC is regulating wheel spin and switches off after the traction control event has ended.
- Flashes continuously when the ATC/Deep Snow & Mud switch is placed in the on position, indicating that this feature is active.

i NOTE

For more information about the stability control system installed on your vehicle, please refer to additional material supplied with this operator manual, included in your glove box informational packet.

3

Traction Control



Monitors wheel speed for poor traction. If a wheel begins to slip due to poor traction, Traction Control will reduce engine power, and or apply brakes in an effort to regain traction.

- Illuminates during the Bulb Check when the ignition is switched ON. The lamp switches off after a few seconds if no system problems are detected. If an ATC problem

! WARNING

If this chassis is equipped with an Electronic Stability Control (ESC) and is modified (e.g. adding or removing an axle, converting from a truck to a tractor, converting from a tractor to a truck, changing the body, lengthening of the wheelbase and/or frame, relocating frame components, or modifying pneumatic or electrical ABS/ESC harnesses) the ESC must be evaluated by a qualified technician. If you have any questions, contact your authorized dealer. Failure to comply may result in death, personal injury, equipment damage, or property damage.

Battery Telltale

Disposition: / Status:
New topic. Please review before publication.



This indicator presents either to warn about a low battery condition or is associated with a gauge indicating battery charge. This indication will be red under low voltage conditions.

Brake System Malfunction

Disposition: / Status:

3

Altered topic. Please review before publication.



One of these indicators appear when a failure has occurred with the brake system. This can result from the following:

- Loss of primary or secondary air
- Loss of air in the trailer brake system
- Fault signal generated in the trailer brake system

This situation should be considered an emergency. Perform actions for *Low Air Actions* on page 31.

Diesel Particulate Filter (DPF)



This warning means that the DPF needs to be regenerated and will appear when soot

in the DPF exceeds an acceptable amount or a significant amount of hydrocarbons (HC) are detected. This warning may also appear if the system is attempting to regenerate automatically while the vehicle is in Power Take-off (PTO) mode. For more information about this warning, consult the Engine Aftertreatment System operator's manual.

i NOTE

This manual describes only the most basic aftertreatment information essential for a driver to operate the vehicle safely. A more thorough explanation of your emissions system can be found in the video linked to the QR code below or in the Engine Aftertreatment Systems Operator's Manual.



Differential, Inter-Axle Lock



Illuminates when the inter-axle differential switch is ON thus locking the inter-axle differential. This powers the forward rear and the rear rear differentials equally. When the switch is turned off (inter-axle differential unlocked) the engine power is allowed to flow to any of the four drive tires based on the differential effect (mostly to the forward rear differential). This feature is standard on all tandem axles.

i NOTE

Disposition: / Status:
Indicator color updated from yellow to amber. Please review.

Tractors/Trucks and trailers built after 03/01/2001 must be able to turn on an In-Cab Trailer ABS Warning Light (per U.S. FMVSS121). The industry chose Power Line Communication (PLC) as the standard method to turn it on. On trailers built prior to 03/01/2001, verify trailer ABS system status via the required external warning light mounted on the trailer. The indicator light on the trailer should be amber and identified with the letters ABS.

Dump Truck, Body Up



Illuminates when Truck Dump Body is up.

Dump Truck, Trailer Body Up



Illuminates when Trailer Dump body is up.

Engine BrakeSaver or Transmission Retarder



Illuminates when BrakeSaver (export only) or Transmission Retarder is active.

Engine Brake Indicator

Disposition: / Status:
Altered topic. Please review before publication.



This indicator appears when engine braking (compression brake or exhaust brake) is enabled. Vehicles capable of

changing the amount of engine braking show available engine braking levels near the indicator, with the selected braking level highlighted:



When actively engine braking, the engine brake indicator turns green. Active engine braking can be overridden when the operator (or a vehicle feature, such as Adaptive Cruise Control (ACC)) provides acceleration.

Engine, Check Engine



Illuminates when a problem exists, but the vehicle can still be safely driven. Vehicle should be serviced to correct the problem, but the situation should not be considered an emergency.

The Check Engine Lamp will activate for several reasons including, but not limited to, Water in Fuel, No-Idle Shutdown alert screens, High Exhaust Temperature, Diesel Particulate Filter (DPF), and Diesel Exhaust Fluid (DEF) warning lights. Refer

to your Engine Operator's Manual for additional information.

3

i NOTE
Only for engines equipped with emissions aftertreatment.

Engine, Low Coolant Level



Illuminates with an audible alarm indicating critically low coolant level. The vehicle must be serviced to correct the problem but the situation should not be considered an emergency.

Engine, Overspeed



Illuminates when engine RPM is exceeded (Allison Transmissions).

Stop Engine



This warning light appears with an audible alarm tone when a major engine system problem exists.

! WARNING
If the stop engine warning light turns on, a serious engine system problem has occurred. Safely stop the vehicle and turn OFF the ignition. Do not drive the vehicle until the vehicle has been serviced. Failure to comply may result in death, personal injury, equipment damage or property damage.

Engine Wait-to-Start Light

This warning icon will appear when the system needs some time before attempting to start the engine. The light will illuminate at key ON, and will stay on for a period of up to 30 seconds.



i NOTE
The length of time the 'Wait-To-Start' lamp remains illuminated depends on the ambient temperature. The lower the ambient temperature, the longer the lamp will be illuminated.

Once the Wait-to-Start light turns off, turn the key to the starting position to start the engine. You may see this appear if the system has detected a situation where the starter is too hot and needs to cool down. Alternatively, you may see it when the engine grid heater is on and needs some time to warm up.

i NOTE

Some engines are equipped with an engine starting motor protection feature. If the starting motor is engaged for 30 or more seconds, without the engine starting, the starter will be locked out from operating, allowing for proper cooling of the starting motor. During this time, the 'Wait-To-Start' lamp will flash for 2 minutes. Once the lamp stops flashing, the starting motor will be allowed to function.

Fast Idle Control

Disposition: / Status:
New Topic. Please review before publication.



Illuminates white when Fast Idle Control is enabled.
Illuminates green when Fast Idle Control is activated.

Emissions, Engine Derate



Illuminates when a derate is active.

Emissions, High Exhaust System Temperature



Illuminates when the exhaust gas temperature and exhaust components become extremely hot.

jury to bystanders and may result in property or equipment damage.

! WARNING

If the High Exhaust System Temperature (HEST) warning light is on, do not park near people. The heat generated by the engine aftertreatment system (EAS) may cause serious burns if EAS components are contacted. Failure to do so may result in property damage, personal injury, or death.

! WARNING

If the High Exhaust System Temperature (HEST) warning light is on, do not park near combustible vapors or materials. You must keep combustibles at least 5 ft. (1.5 m) away from the exhaust (outlet) stream as it exits the tail pipe while the HEST light is illuminated. Failure to do so could ignite an explosion and cause death or serious in-

3

WARNING

When the High Exhaust System Temperature (HEST) warning light is on, the temperature of the tailpipe, exhaust pipes, diesel particulate filter (DPF)/selective catalytic reduction (SCR) device, and surrounding components (including enclosures and steps) becomes elevated and can cause serious burns to the skin. Allow adequate cooling time before approaching, or working on or near, any part of the exhaust system or surrounding components. Failure to comply may result in death, personal injury, equipment damage or property damage.

Hill Start Aid (HSA) Disabled Warning Light (option)



This warning means that the Hill Start Aid (HSA) feature is disabled. This may be

from use of the Hill Start Aid Disable switch (see Hill Start Aid Disable Switch) or a fault with the HSA feature.

Lane Departure Warning (LDW)



Illuminates when LDW system is not able to track the vehicle's position within the lane.

i NOTE

For vehicles equipped with Lane Departure Warning, please refer to Lane Departure Warning Driver's Guide for additional information.

Lights, High Beam



Illuminates when the high beams are on. This icon will flash with an audible alarm if the headlights are left ON when the door is opened and the key switch is OFF.

In addition, this icon will flash, but without an audible alarm, if there is a problem with the low beam headlights or the low beam headlight wiring. In such event, the high beam headlights will turn on at 50% normal brightness.

Malfunction Indicator Lamp (MIL)



Illuminates when an engine emissions failure has occurred. The vehicle can be safely driven but should be serviced to correct the problem. The situation should not be considered an emergency. In some cases, the Malfunction Indicator Lamp will activate in conjunction with the High Exhaust Temperature, Diesel Particulate Filter (DPF) and Diesel Exhaust Fluid (DEF) Warning Lights.

i NOTE

Only for engines equipped with emissions aftertreatment.

Message Waiting (Option)



Illuminates with telematic-equipped messaging.

Park Brake



Illuminates when parking brake is applied. The Park Brake lamp will flash and the warning tone will sound anytime the Park Brake is not set and the driver's door is open.

Audible alarm will sound if the park brake is set and speed is greater than 5 miles per hour.

Seat Belt, Fasten



Illuminates for 5 seconds whenever the ignition key is turned on, then it turns off.¹²

Transmission, Failure

Disposition: / Status:
Altered title, please review before publication.



Indicates a fault with the transmission. Refer to transmission manual.

Transmission, Oil Temperature High



Illuminates when transmission lubricant temperature is too high.

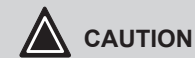

This should be considered an emergency. You should stop the vehicle as safely as possible and turn OFF the ignition. The vehicle must be serviced and the problem corrected before driving again. Failure to do so may cause severe transmission damage.

Transmission, Service

Disposition: / Status:
New topic. Please review before publication.



Indicates that the transmission needs service. Symbol may differ based on transmission optioning. Refer to

3

¹² The warning lamp may also come on if the driver's seat belt is not fastened (if the vehicle was ordered with a seat belt warning light option).

transmission operator's manual for more information.

Turn Signal, Left

3



Blinks when the left turn signal or the hazard light function is operating.

Turn Signal, Right



Blinks when the right turn signal or the hazard light function is operating.

Steering Wheel Controls (Option)

 CAUTION
Under no circumstances should you attempt to service the steering wheel, clockspring, or any of the electrical wiring in the multiplex system, or any steering components (steering column, steering driveline or steering gear). Tampering with these components may result in an inoperable multiplex system.

The steering wheel may provide controls for commonly used functions, so that their use does not require the operator to take their hands off of the steering wheel. These controls are also used to interface with the display.

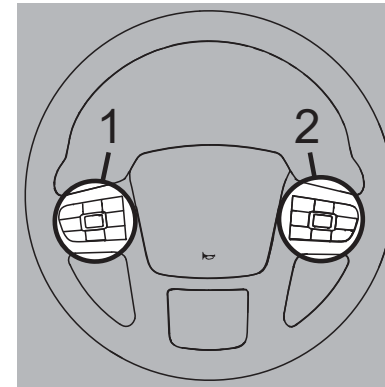

- 1. Left switch pod
- 2. Right switch pod

The switches on the left side of the horn pad, including the toggle switch, manage vehicle speed functions including cruise control and optional features such as variable road speed limiter and adaptive cruise control (see [Left Switch Pod](#)). Switches on the right side control infotainment ([Radio Stereo System](#)) and navigate and configure the digital display (see [Right Switch Pod](#) on page 81).

City Horn

Depressing the horn pad in the center of the steering wheel activates the city horn.

Left Switch Pod

The left switch pod on the steering wheel contains buttons for the trip and cruise control features. See *Cruise Control* on page 136.

Disposition: / Status:
Illustration and callouts list formatting adjusted.

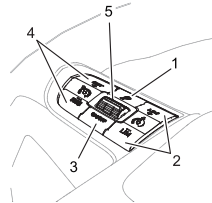

1. Trip
2. Variable Road Speed Limiter (VRSL) **LIM+** and **LIM-** (option)
3. Cruise Control **ON/OFF**
4. Cruise Control (CC) **SET+** and **RES-**

5. **Toggle**

Trip

Starts a trip or sub-trip. A long press will clear all trip data.

Variable Road Speed Limiter (VRSL) LIM+ and LIM- (option)

Disposition: / Status:
New sections added per SME comments. Please review.

This feature allows the operator to set an upper-limit speed for the vehicle and do not exceed this chosen speed limit. The speed can be changed while driving by using the LIM+ and LIM- buttons. VRSL cancels the Cruise Control (CC) when active.

Cruise Control ON/OFF

By pressing the ON/OFF buttons the Cruise Control is activated or deactivated.

Cruise Control (CC) SET+ and RES-

The SET+ button sets the Cruise Control speed. The RES- button resumes the previously set speed. Also, these buttons increase or decrease the Cruise Control (CC) set speed by holding down the SET+

or RES- while accelerating or decelerating the vehicle.

Toggle

This switch is optional for vehicles equipped with Adaptive Cruise Control (ACC) or Predictive Cruise Control (PCC). The toggle has toggle up, toggle down, and toggle press functionality to adjust the ACC or PCC features in the Digital Display (DD).

Right Switch Pod

The controls located on the right pod of the steering wheel are used to select the View, navigate, and select items in the Menu, and view notifications.

Disposition: / Status:
Illustration and callouts list formatting adjusted.

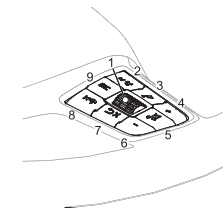

CONTROLS - Steering Wheel Controls (Option)

3

1. **Scroll Wheel**
2. **Next/Accept**
3. Not used
4. **Volume Increase**
5. **Mute**
6. **Volume Decrease**
7. **Back/Cancel**
8. **Previous/Cancel**
9. **Media Source**

Scroll Wheel

Disposition: / Status:
Grammar error fixed per SME request; "by rotatinf it up and down" added for precision. Please review.

Use the scroll wheel to navigate through menus. The scroll wheel is bidirectional and is also a button. Press down on the scroll wheel to select menu options, to change settings when in the menu, and to switch between Views.

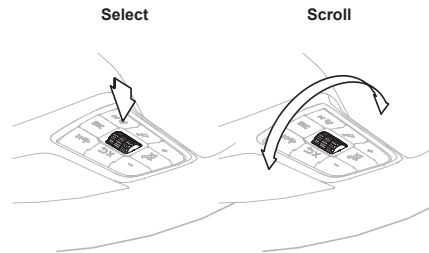

For example, vehicle time can be set using the Scroll Wheel.
Press down (**Select**) to open the menu:

Menu Example: Main

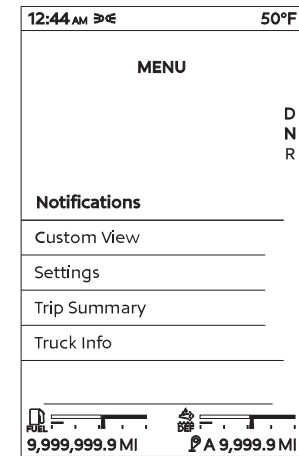

Scroll to Settings and then **(Select)** again to choose the Settings sub-menu: Then **Scroll** to Set Time and press **Select**.

Menu Example: Time

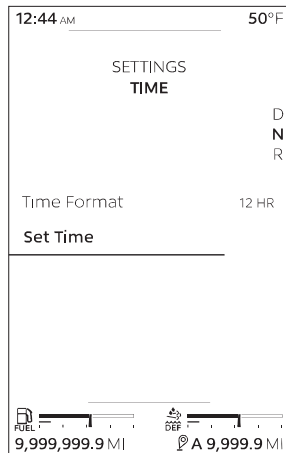

Finally, **Scroll** through the values and press **Select** to set the time.

Menu Example Set Function

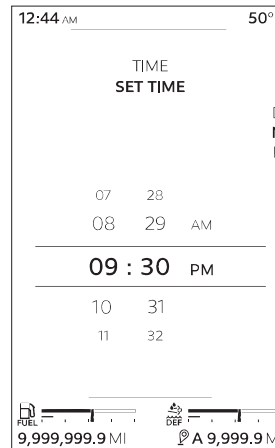

The display indicates that the Scroll Wheel can be used to **Select** with this icon:

Select



Back/Cancel

Use the **Back/Cancel** button to return to the previous menu, suppress a notification,

or cancel a selection. See [Notifications](#) on page 57.







Dash Switches







Disposition: / Status:
Table switches altered/updated per Steve Jahns' feedback. **Please review before publication.**

This custom vehicle will have a wide variety of switch-controlled equipment. However, this particular vehicle may not have every switch identified in this section of the operator manual. Some air device switches on the dash may require that the vehicle either be at a specific speed, have park brakes set, or another device to be on or off for the air device to operate. The instrument display will show information regarding what needs to change in order for the air device to operate as expected. The following table provides a complete list of icons that may be found on the switch.

CONTROLS - Dash Switches







3

Title	Symbol	Color	Stnd	Opt
<i>Axle, Automatic Traction Control</i> on page 91		None	•	
<i>Axle, Diff. Lock - Dual</i> on page 91		Green		•
<i>Axle, Diff-Lock - Forward Rear</i> on page 91		Green		•
<i>Axle, Diff-Lock - Steer</i> on page 91		Green		•
<i>Axle, Diff-Lock - Rear Rear</i> on page 91		Green		•
<i>Axle, Diff-Lock - Single Rear</i> on page 91		Green		•







Title	Symbol	Color	Std	Opt
<i>Axle, Inter-Axle Differential Locked (Tandem)</i> on page 92		Green		•
<i>Axle, Two Speed</i> on page 92		Green		•
<i>Brakes, ABS Off-Road</i> on page 92		Green		•
<i>Brake, Parking Brake Valve</i> on page 92		Yellow	•	
<i>Brake, Trailer Hand</i> on page 92		None		•
<i>Dump Truck Gate</i> on page 93		Red		•

CONTROLS - Dash Switches

3

Title	Symbol	Color	Std	Opt
<i>Engine, Brake Level</i> on page 93		None		•
<i>Engine, Brake On/Off</i> on page 93		Green		•
<i>Engine, Cruise Control On/Off</i> on page 93		Green	•	•
<i>Engine, Cruise Control Set/Resume</i> on page 93		None	•	•
<i>Engine Fan Override</i> on page 93		Green		•
<i>Regeneration Control (Diesel Particulate Filter - DPF)</i> on page 102		None		•
<i>Fifth Wheel Slide</i> on page 94		Red		•







CONTROLS - Dash Switches





Title	Symbol	Color	Std	Opt
<i>Fuel Heater</i> on page 94		Green		•
<i>Accessory Air (up to 4)</i> on page 90	 	Green		•
<i>Accessory – Spare(s)</i> on page 91	SPARE 	Green		•
<i>Ignition Key Switch</i> on page 95		None	•	
<i>Kingpin Release</i> on page 95		Red		•

3

CONTROLS - Dash Switches

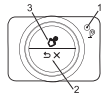



3

Title	Symbol	Color	Std	Opt
<i>Lights, Beacon</i> on page 96		Green		•
<i>Lights, Daytime Running (Override)</i> on page 96		Green		•
<i>Lights, Work</i> on page 100		Green		•
<i>Lights, Fog</i> on page 100		Green		•
<i>Lights, Footwell (option)</i> on page 100		Green		•
<i>Lights, Exterior Lights Switch (ELS)</i> on page 97		Green	•	

Title	Symbol	Color	Std	Opt
<i>Lights, Spot</i> on page 100		Green		•
<i>Menu Control Switch</i> on page 100		None	•	
<i>Power Take-off (PTO)</i> on page 101		Green		•
<i>Lift Axles – Pushers (up to 3)</i> on page 96		Green		•
<i>Suspension, Axle, Tag</i> on page 102		Green		•

CONTROLS - Dash Switches

3

Title	Symbol	Color	Stnd	Opt
<i>Vehicle/Trailer Air Supply Valve</i> on page 147		Red	•	
<i>Belly Dump Trailer Gates (Fwd., Center, and Rear)</i> on page 92		Red		•
<i>Trailer, Dump Gate</i> on page 103		Red		•
<i>Trailer, Suspension Air Dump</i> on page 103		Green		•
<i>Winch Clutch</i> on page 103		Red		•

Accessory Air (up to 4)

Disposition: / Status:

New topic based on the standard xya1688135894079. Please review.



Provides accessory air at the frame mounted solenoid bank. Air hose plumbing will need to be added to the solenoid bank to connect to the accessory that is intended to control with air accessory switch. Up to four Accessory Air switches can be optioned and they are sequentially numbered after 1.

Accessory – Spare(s)

Disposition: / Status:
 New topic based on the standard bil1438106773032. Please review.

SPARE through **SPARE**
A **L**

Turn switch on to power customer installed accessory. There are multiple switches possible: Peterbilt uses numbered (1 through 5) and lettered (A through L) sequences while Kenworth uses only numbers (1 through 5).

Axle, Automatic Traction Control



Briefly push switch in to engage Deep Mud and Snow Traction Control. See Deep Snow and Mud Switch on page 4-34.

Axle, Diff. Lock - Dual



Turn switch on to engage Front and Rear Axle Diff Lock.

Axle, Diff-Lock - Forward Rear



Turn switch on to engage Forward Rear Axle Diff Lock.

Axle, Diff-Lock - Steer



Turn switch on to engage Front Axle Diff Lock.

Axle, Diff-Lock - Rear Rear



Turn switch on to engage Rear Rear Axle Diff Lock.

Axle, Diff-Lock - Single Rear



Turn switch on to engage Single Rear Axle Diff Lock.

3

Axle, Inter-Axle Differential Locked (Tandem)



Turn switch on to engage Inter-Axle Differential Lock.

Axle, Two Speed



If equipped, the two speed axle switch allows you to select axle high and low ranges. The low range (Off) provides maximum torque for operating off-highway. The high range (On) is a faster ratio for highway speeds.

Back Up Alarm Mute



Turn switch on to mute Back Up Alarm.

	<p>NOTE</p> <p>The mute function use is discouraged. Only use mute when legally required.</p>
---	--

Belly Dump Trailer Gates (Fwd., Center, and Rear)

Disposition: / Status:
 New topic based on the following topic: bil1438106779335, bil1438106779693, and bil1438106780052) per SME request. Please review.



Turn switch on to open belly dump trailer gates, either forward, center, or rear gates. Peterbilt offers two switches, forward and rear. Kenworth offers all three in Electric Over Air (EOA) configuration, but only forward and rear switches in electrical configuration—like Peterbilt.

Brakes, ABS Off-Road



Turn switch on to engage ABS Off-Road mode. See [Antilock Brake System \(ABS\)](#) on page 70.

Brake, Parking Brake Valve



Pull yellow knob to activate parking brake.

Brake, Trailer Hand



This dash mounted switch provides air pressure to apply the trailer brake only. It operates independently of the foot treadle valve.

Dump Truck Gate



Turn switch on to open Dump Truck Gate.

Engine, Brake Level



If the engine brake is on, the up position will provide 100% engine braking, the middle position 60%, and the down position 33% engine braking when engine braking is active.

For more information on when and how to use the engine brake in your vehicle, see the engine brake owner's manual for additional engine brake information.

Engine, Brake On/Off



Turn switch **ON** to activate Engine Brake system. This symbol is also used for an exhaust brake. Vehicles equipped with an engine brake will not also have an exhaust brake. For more information on when and how to use the engine brake in your vehicle, see the engine brake owner's manual for additional engine brake information.

Engine, Cruise Control On/Off



Turn switch on to activate Cruise Control System.

Engine, Cruise Control Set/Resume



The Cruise Control Set/Resume switch allows you to **SET** the desired speed or **RESUME** the desired speed after the cruise control function has been interrupted.

Engine Fan Override



The engine fan switch allows you to control the engine fan manually or automatically. With the ignition key switch ON and the fan switch in the MANUAL position, the engine fan will be on regardless of engine temperature. With the engine fan switch in the AUTOMATIC position, the engine fan will automatically turn on when the engine coolant reaches a temperature of about 200°F (93°C) or when the air conditioning system has reached set point pressure. With an electronic engine, the fan may also be activated by air intake temperature, oil temperature and compression brake usage.

3

⚠ WARNING

DO NOT work on or near the fan with the engine running. Anyone near the engine fan when it turns on could be injured. If it is set at MANUAL, the fan will turn on any time the ignition key switch is turned to the ON position. In AUTO, it could engage suddenly without warning. Before turning on the ignition or switching from AUTO to MANUAL, be sure no workers are near the fan. Failure to comply may result in death or personal injury.

⚠ CAUTION

The fan or equipment near it could be damaged if the fan turns on suddenly when you do not expect it. Keep all tools and equipment away from the fan. Failure to comply may result in equipment or property damage.

⚠ CAUTION

DO NOT operate the engine fan in the MANUAL position for extended periods of time. The fan hub was designed for intermittent operation. Sustained operation will shorten the fan hub's service life as well as reduce fuel economy. Failure to comply may result in equipment or property damage.

Fifth Wheel Slide



Turn switch on to unlock Fifth Wheel Slide mechanism. The switch is guarded to protect you from accidentally activating or releasing the lock.

⚠ WARNING

DO NOT move the fifth wheel while the tractor-trailer is in motion. Your load could shift suddenly, causing you to lose control of the vehicle. Never

operate the vehicle with the switch in the UNLOCK position. Always inspect the fifth wheel after you lock the switch to be sure the fifth wheel slide lock is engaged. Failure to comply may result in death, personal injury, equipment or property damage.

i NOTE

Vehicles having an air slide fifth wheel have a fifth wheel slider lock controlled by a switch on the instrument panel. By placing the switch in the unlock position you can slide the fifth wheel to various positions to adjust weight distribution.

Fuel Heater



Turn switch on to activate Fuel Heater.

Hill Start Aid (HSA) Disable Switch (option)

Two-position Switch



Positions:

- **OFF** (temporary position)
- **ON** (center, resting position)

OFF Pressing the switch up temporarily disables the Hill Start Aid feature. Disabling Hill Start Aid presents both a notification and a warning light (see [Hill Start Aid \(HSA\) Disabled Warning Light \(option\)](#) on page 78).

Hill Start Aid is automatically re-enabled after the first successful launch.

Ignition Key Switch

The ignition key switch located to the right of the steering column has four positions: ACC (Accessories), OFF, ON, and START.

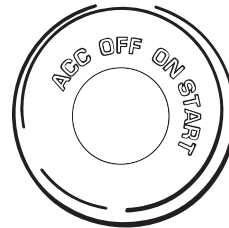

OFF: In this position all accessories are OFF (except those listed below) and you can remove the key.

The following lights and accessories have power when the key is in the OFF position:

- Brake Lights
- Emergency Hazard Flasher
- Dome and Courtesy Lamps (on doors)
- City Horn
- Cigarette Lighter
- Tail Lights
- Marker Lamps
- Headlights
- Radio Station Memory
- Instrument Lights
- Auxiliary Power

- Instrument Panel Memory Settings

ACC (Accessory): With the key in this position you can play the radio, defrost mirrors (if equipped with mirror heat) or use other accessories.

ON: In the ON position all circuits are energized. Panel warning lights will light and the buzzer will sound until (1) the engine is started, (2) normal oil operating pressure is reached, and (3) air brake system pressure is above 65 psi (441 kPa). In this position, the ignition key cannot be removed.

START: Turn the key to this position to start your engine. Release the key after the engine has started.

Kingpin Release



Push and hold switch to unlock the fifth wheel, releasing the kingpin. The switch is guarded to protect you from accidentally releasing the lock. See [Releasing the Kingpin Remotely \(option\)](#) on page 167.

3

Lane Departure Warning Disable



Vehicles equipped with this optional switch will disable the audible and visual Lane Departure Warning for 15 minutes after which time, or upon key cycle, the feature will re-enable. The feature may also be re-enabled by toggling the switch again while disabled. The switch will not affect any of the Adaptive Cruise Control warnings.

Lift Axles – Pushers (up to 3)

Disposition: / Status:
 New topic based on the standard bil1438106777619. Please review before publication.



to



Turn switch on to lower Single or Forward Pusher Axle. These switches are

numbered sequentially going forward from the drive axles. Medium Duty models allow up to three.

Lights, Beacon

Disposition: / Status:
 Altered topic per SME request. Please review before publication.



Turn switch on for Beacon Light(s). In Medium Duty two types of switches are optioned: a traditional rocker switch and a push button over on the left panel.

Lights, Cab and Panel Dimmer Switch

Disposition: / Status:
 Altered topic. Please review before publication.



This switch alters the brightness of the instrument panel lights and ambient lighting. It also controls the cab overhead.

i NOTE
 The Headlight Switch is an ON or OFF switch. The panel lights are on full intensity during the day and dim when headlights are on.

Lights, Daytime Running (Override)



This switch overrides the normal operation of the Day Time Running Light (DRL) system. During normal operation, the DRL will turn on lights when the headlights are turned off, engine is on, and the park brakes are disengaged. The override switch will turn the DRL off in these instances. The DRL is also turned off when the headlights are turned ON.

WARNING

DO NOT use daytime running lights (DRL) during periods of darkness or reduced visibility. DO NOT use DRL as a substitute for headlights or other lights during operations that require lighting of your vehicle. Failure to comply may result in personal injury, property damage or death.

If the headlight switch is turned OFF, the DRL system engages automatically after the engine starts and you release the parking brake. If the headlight switch is ON, the DRL system is overridden, and headlights operate normally. Also, the DRL is temporarily turned off during engine cranking.

Lights, Exterior Lights Switch (ELS)

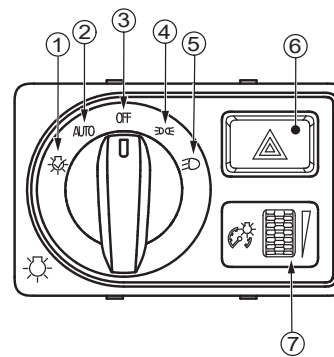

1. ELST
2. AUTO
3. OFF
4. AUX
5. Headlights
6. Hazard Lights
7. Cab and Panel Dimmer Switch

ELST

Starts an Exterior Lights Self Test (ELST). See [Exterior Lighting Self-Test \(ELST\)](#) on page 99).

AUTO (Automatic Headlights)

Automatic Headlights turns on the vehicle exterior lights when a low-light condition is detected and turns off those lights when lighting conditions brighten. When enabled, *Automatic Headlights* turns on the following lights during a low-light condition:

- Low beam headlights
- Parking
- Clearance and Identification (tractor and trailer)
- Marker lights (tractor and trailer)
- Tail (tractor and trailer)
- License plate (tractor and trailer)

OFF

Turns off all exterior lights. DRL may still be active (see [Lights, Daytime Running \(Override\)](#) on page 96).

3

AUX (Auxiliary Lights)

Turns on marker lights¹³ or parking and marker lights based on parking brake position:

- Parking brake set - parking, marker, tail, and license lights.
- Parking brake released - marker, tail, and license lights.

Headlights

Turns on low beam headlights, tail, license, and marker lights¹⁴. High beam headlights are activated using the turn signal lever (see *High Beam Operation* on page 107).

	<p>NOTE</p>
<p>Disposition: / Status: Note revised. Please review.</p>	
<p>The high beams and flash-to-warn activation methods use the same action. To activate the high beams, turn the low beams ON. To activate flash-to-warn, turn the low beams OFF.</p>	

 <p>WARNING</p>
<p>Disposition: / Status: Warning revised. Please review.</p>
<p>If the vehicle's low beam wiring circuit does not function correctly, pull completely off the road and call the nearest dealer for assistance. DO NOT drive the vehicle using the high beams, as high beam glare can blind other drivers and increase the risk of an accident. Failure to comply may result in death, personal injury, equipment damage, or property damage.</p>

Hazard Lights

This button operates the hazard lights. When pressed, all four turn signals (front and rear) will continuously flash. Press the button again to turn off the hazard lights. Hazard lights work independent of the ignition switch position. You should always use the emergency hazard lights if the vehicle is disabled or parked under emergency conditions.

 <p>WARNING</p>
<p>Disposition: / Status: Warning revised. Please review.</p>
<p>Be aware of all governing Hazard Warning Light laws and keep all necessary emergency signals in the vehicle per FMCSR 392.22. During unusual or emergency situations, use all relevant lights and signals since hard-to-see vehicles can increase the risk of accidents. Failure to comply may result in death, personal injury, equipment damage, or property damage.</p>

Cab and Panel Dimmer Switch

This switch is used to alter the brightness of the instrument panel lights, ambient lights, and cab overhead lights.

¹³ Marker lights consist of side markers, clearance, ID roof markers, and mud flap (optional) lights.
¹⁴ Marker lights consist of tail, side marker, clearance, ID roof marker, and mud flap (optional) lights.

**NOTE**

The Headlight Switch is an ON or OFF switch. The panel lights are on full intensity during the day and dim when headlights are on.

Exterior Lighting Self-Test (ELST)

The Exterior Lighting Self-Test (ELST) allows the operator to examine all exterior lights as part of a pre-trip inspection. An ELST can be activated via the dash switch or the key fob. A full ELST can only be activated with the ignition switch in the ON position; otherwise, a limited ELST is performed.

The ELST will run for fifteen minutes. Exterior light functionality can be verified by watching the lights from outside the vehicle and by reading the instrument cluster for displayed faults. The operator may interrupt the test by turning the vehicle off or activating the switch a second time while the test is running. The ELST will

also start the system check ([Systems Check](#) on page 27).

Full ELST

When a full ELST is activated, it will alternately turn on and then off the following lights:

- Park lights
- License plate lights
- Hazard/turn signals
- Low beam headlights
- High beam headlights
- First set of fog/driving lights
- Tail lights
- Stop lights
- Reverse lights
- Fog lights (option)
- Driving lights (option)
- Daytime Running Lights (option)

The following lights stay on during the duration of a full test:

- Clearance lights
- Identification lights
- Side Marker lights
- Beacon/Strobe (option)
- Work/Load lights (option)
- Sign light (option)

Limited ELST

A limited ELST will alternately turn on and then off the following lights:

- Hazard/turn signals
- Low beam headlights
- High beam headlights
- Park lights
- Daytime running lights (option)
- License plate lights
- Tail lights
- Stop lights

The following lights will stay on during the duration of a limited test:

- Clearance lights
- Identification lights
- Side marker lights

Test the Exterior Lights

For a full ELST, the parking brake must be set and the ignition switch must be in the ON position. For a limited ELST, the ignition switch must be in the ACC or OFF position.

A full ELST will test all exterior lights (also checking the mirror and headlight heaters if the engine is on). A limited ELST will test only the legal driving lights.

3

1. Turn the **Exterior Lighting Switch (ELS)** to the momentary ELST position and release the switch, or



The ELST icon will illuminate.

2. Press the **ELST button** on the key fob.

A full ELST will continue until the parking brake is released or the ignition switch is turned to OFF. Both the full and limited ELST will stop if either the dash or key fob ELST buttons are pressed, or the fifteen minute test duration has elapsed.

Lights, Work

Disposition: / Status:
 Altered topic per SME request.
 Please review before publication.



Turn switch on for cab mounted Flood Lights. Switches 1 and 2 are push buttons, but 3 is a rocker switch.

Lights, Flood ISO 3732 Spare



Turn switch on for trailer mounted Flood Lights.

Lights, Fog



Turn switch on for Fog Lights.

i NOTE
 Fog lights should be used in the presence of fog, rain, dust, snow, or smoke. Do not use during general operation because this is illegal in some locations.

i NOTE
 Across the U.S.A. and Canada, State/ Provincial requirements vary as to

when high beams and fog lights can and cannot be used together. Some states allow only four lights to be used together, while some allow more. How your lights are arranged will affect whether you can operate headlights and fog lights concurrently always comply with the state or provincial requirements where you are driving.

Lights, Footwell (option)



Two position switch that illuminates both the driver and passenger side foot space.

Lights, Spot



Turn switch on for Spot Light.

Menu Control Switch

Disposition: / Status:

Altered Topic. Please review before publication.

The Menu Control Switch (MCS) is a dial with buttons.

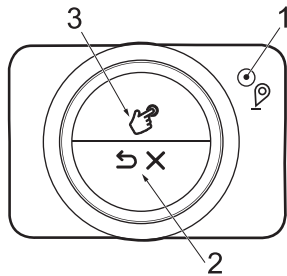

1. **Waypoint Marker** – Tracks time of trip. A long press will clear all trip data.
2. **Back/Cancel** – Withdraws from changing a setting, returns to the previous menu, or suppresses a warning.
3. **Select** – Chooses menu selections, acknowledges warnings (called suppressing), and activates some drive views.

The display indicates when **Select** may be used with this icon:



Pintle Hook

Disposition: / Status:
Altered topic. Please review before publication.



Turn switch on to remove the slack from the hook. For Kenworth this is a rocket launcher switch.

Power Take-off (PTO)

Disposition: / Status:
Altered Topic. Please review before publication.



This vehicle may be equipped with a dash-mounted switch that controls PTO engagement/disengagement. When the operator activates the switch for the PTO, the status indicator light (located on the switch) will immediately illuminate even though PTO engagement may not have occurred. If the PTO is engaged and the operator turns the switch **OFF**, the PTO status indicator light (located on the switch) will turn off immediately even though PTO disengagement may not have occurred.

CAUTION

Increasing engine rpm before the PTO is engaged can prevent the PTO from engaging and/or cause PTO damage.

NOTE

Disposition: / Status:
Altered note. Please review before publication.

Actual PTO engagement/disengagement can be momentarily delayed.

3

3

i NOTE

i NOTE

Disposition: / Status:
 New note. Please review before publication.

Actual PTO status may be indicated on dash display depending on vehicle configuration.

Regeneration Control (Diesel Particulate Filter - DPF)

Disposition: / Status:
 New topic based on the standard bil1438106772252. Please review.



Manually controls the diesel particulate filter (DPF) regeneration process. In Medium Duty models, two different configurations are possible; the switch

above forces a regeneration but does not allow disablement.



The Disable DPF switch can both force a regeneration and allow disablement. The Peterbilt switch lights up green when activated. Kenworth also offers this switch but it lights up amber. Refer to Engine Aftertreatment Controls Operator's Manual for additional information.

Suspension, Air Retention

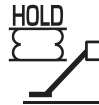

The Air Retention Switch keeps the air suspension bags from losing air pressure when used with vehicle outriggers. Depress the Air Retention Switch prior to deploying the outriggers. While outriggers are deployed, axle stability is maintained.

Suspension, Axle, Tag

Disposition: / Status:

Contact SME and consider replacing with snk1536867270085.xml

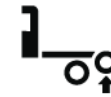

Turn switch on to lower tag axle.

Suspension, Dump



Turn switch on to deflate suspension air bags. The switch is guarded to protect you from accidentally deflating the suspension.



WARNING

DO NOT operate the Air Suspension Deflate Switch (Dump Valve) while driving. Sudden deflation while your vehicle is moving can affect handling and control and could lead to an accident. Use this switch only when your vehicle is not moving. Failure to comply may result in death, personal injury, property damage, or equipment damage.



CAUTION

Operating a vehicle with air suspension bags either overinflated or underinflated may cause damage to drive-line components. If a vehicle must be operated under such conditions, do not exceed 5 mph (8 km/h). Failure to comply may result in equipment damage.

Suspension, Lift

Disposition: / Status:

New topic to map. Please review.

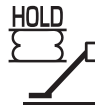

Turn switch on to over-inflate suspension air bags. Turn switch off for normal suspension height.



CAUTION

Operating a vehicle with air suspension bags either overinflated or underinflated may cause damage to drive-line components. If a vehicle must be operated under such conditions, do not exceed 5 mph (8 km/h). Failure to comply may result in equipment damage.

Trailer Air Supply



The red octagonal knob controls the air supply to the trailer.

Trailer, Dump Gate

Disposition: / Status:
Check this graphic against PTC-265a to determine accuracy.



Turn switch on to open Trailer Dump Gate.

Trailer, Suspension Air Dump

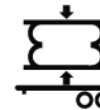

Turn switch on to deflate trailer air suspension.

Winch Clutch



Turn switch on to engage winch clutch.

3

3

Steering Column Controls

Disposition: / Status:
Altered topic. Please review before publication.

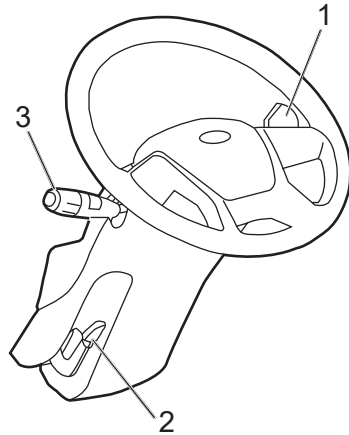

- 1. Column Shifter (option)
- 2. Tilt/telescope lever
- 3. Turn signal/wiper/lights

The turn signal lever is mounted on the left side of the steering column. The lever controls several functions: turn signal, high

beam, and windshield wiper control. The turn signals will only operate when the key is in the ignition in the ACC or ON position.

Tilt/Telescoping Steering Wheel

Disposition: / Status:
Altered description below. Please review.

The vehicle is equipped with a steering column that allows adjustment in the angle, height, and distance of the steering wheel away from the driver. A release handle is present on the left side of the steering column.

WARNING

Make all adjustments to the steering mechanism while the vehicle is stopped. Adjusting the Tilt Telescoping Steering Wheel while the vehicle is in motion could cause loss of control and may lead to an accident resulting in death or personal injury. Failure to comply may result in death, personal injury, equipment damage, or property damage.

Column Shifter

Column Shifter (option)

Disposition: / Status:
Altered Topic. Please review before Publication.

This vehicle may be equipped with a column shifter located on the right-hand side of the steering column. The column shifter can perform the following transmission functions:

Disposition: / Status:
"Engine Brake" added to the list below, per SME request. Please review.

- Transmission Mode selection (**D - N - R** or **D - N - R - P**)
- Manual and Automatic Mode selection
- Upshifting and Downshifting (includes **Low** Mode)
- Engine Brake

Transmission Mode

Disposition: / Status:
Altered topic. Please review before publication.

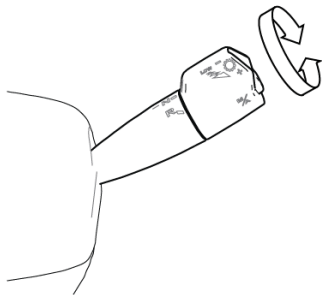

The Digital Display will indicate the corresponding mode.

i NOTE
Vehicles without a Park (P) mode must be in Neutral (N) to start the truck.

Manual and Automatic Mode

The transmission mode is selected by rotating the lever outer knob. There is a position for Drive (D), Neutral (N), and Reverse (R) and for some vehicles Park (P). Rotating the knob to the Park (P) or Reverse (R) position while the vehicle is moving forward, or to the Park (P) or Drive (D) position while the vehicle is moving backward, will not change the transmission mode to those selections or will drop the transmission to Neutral (N) if vehicle speed is not slow enough to execute the requested change depending on transmission configuration.

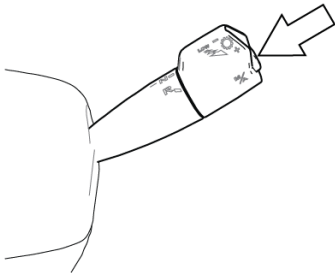

This button will put the transmission into manual mode. Manual mode will allow the operator to select the gear (See Upshifting and Downshifting).

To activate, put the gear selector in the D (drive) mode and then depress the M/A button. When Manual Mode is selected, a M is shown in the Transmission Gear Display ([Transmission Gear Display](#) on page 141).

Upshifting and Downshifting

Disposition: / Status:
Altered Topic. Please review before publication.

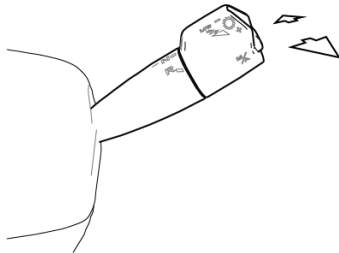

Manually upshifting and downshifting selects the transmission gear in order to accommodate the driving needs of the operator. The Transmission Mode must be

3

in Drive (D) for the transmission to acknowledge an upshift or downshifting request from the column shifter. When in Manual mode, the transmission gears can be manually selected by pushing or pulling on the column shifter. Pulling the column shifter towards the driver will upshift the transmission (+). Pushing the column shifter forward will downshift (-). Pushing and holding the column shifter forward will engage the LOW gear range. When in Automatic mode, pushing or pulling the column shifter will briefly upshift or downshift the transmission gear respectively; after which, the transmission will return to the ideal gearing for the current vehicle speed and engine use. The selected gear will appear beside the transmission mode on Transmission Gear Display (*Transmission Gear Display* on page 141).

Tilt/Steering Lever

Turn Signal Lever

Stop/Turn Signal Lamp Operation

Your vehicle uses combined stop/turn signal lamps at the rear of the vehicle, using the same lamp to perform both functions. This means a single lamp is

used for the brake lamp as well as the turn signal lamp. This lamp will burn steadily with the brakes applied. The same lamp will flash with the turn signal activated, even with the brakes applied.

How to Use the Turn Signal

The lever-action turn signal/high beam switch is located on the left side of the steering column. The ignition key must be turned to ON for the signal/switch to operate.

	NOTE
<p>If the vehicle turn signals and turn signal indicators in the dash gauge cluster ever begin flashing at an accelerated rate (115 cycles per minute) when the turn signal lever is in the OFF (center) position, or when a Right/Left turn has been selected, the problem may be related to a failed turn signal switch or turn signal module. In either case, the problem is not a failed bulb. Contact your nearest authorized dealer to have the problem corrected as soon as possible.</p>	

1. Push the **Signal stalk** lever up to engage the RIGHT turn signal and down to engage the LEFT turn signal.

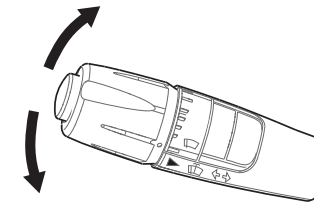

2. Release the signal stalk.
3. The turn signal will cancel when the turn is complete.

An audible beep is associated with each time a turn indicator is activated.

	WARNING
<p>After you complete a turn, shut the system off by returning the lever to the "OFF" (center) position. Failure to shut off a turn signal could confuse other drivers and result in an accident. An indicator light in the instrument panel will flash until the turn signal is turned off.</p>	

High Beam Operation

Disposition: / Status:
Topic revised. Please review.

WARNING

DO NOT use high beams in the presence of oncoming traffic. High beam glare can blind other drivers which increases the risk of an accident. Failure to comply may result in death, personal injury, equipment, or property damage.

NOTE

Disposition: / Status:
Note revised. Please review.

The high beams and flash-to-warn activation methods use the same action. To activate the high beams, turn the low beams ON. To activate flash-to-warn, turn the low beams OFF.

High beams are operated using the turn signal lever:

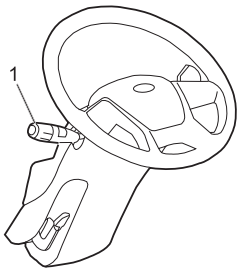

1. Turn signal lever

1. Pull the **Turn Signal** lever toward the operator to turn on high beams.

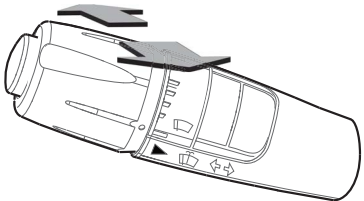

2. Release the **Turn Signal** lever to the original position.

The blue high beams indicator light on the instrument panel will turn on at the same time. Repeat the process to return to low beams.

Flash-to-Warn

Disposition: / Status:
Topic revised. Please review.

WARNING

DO NOT use high beams in the presence of oncoming traffic. High beam glare can blind other drivers which increases the risk of an accident. Failure to comply may result in death, personal injury, equipment, or property damage.

NOTE

Disposition: / Status:
Note revised. Please review.

The high beams and flash-to-warn activation methods use the same action. To activate the high beams, turn the low beams ON. To activate flash-to-warn, turn the low beams OFF.

3

Flash-to-warn, or “high beams flash”, allows the operator to warn other drivers by briefly flashing the high beam headlights.

To activate flash-to-warn:

1. Pull the turn signal lever toward the operator to turn on high beams.

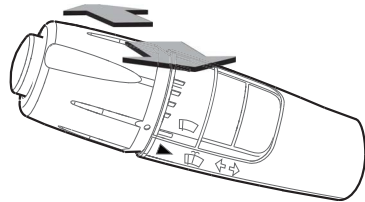

2. Release the turn signal lever to the original position to turn off high beams.

The blue high beams indicator light on the instrument panel will momentarily turn on while the high beams are active.

WARNING

Disposition: / Status:
New warning. Please review.

DO NOT hold the turn signal lever longer than necessary when activating flash-to-warn. The high beams could

blind other drivers and increase the risk of an accident. Failure to comply may result in death, personal injury, equipment, or property damage

Flash-to-Pass

Disposition: / Status:
Topic revised. Please review.

Flash-to-pass, sometimes called “low beams flash”, allows the operator to signal other drivers. The flash looks different depending on the vehicle’s headlight type. Halogen headlamps act one of three ways based on the headlight’s initial state:

- If the low beam headlights are on, the flash-to-pass operation will momentarily dim the headlights.
- If the low beam headlights are off, the flash-to-pass will turn on and then flash the low beam headlights.
- If the high beam headlights are on, the flash-to-pass will turn off the high beams and flash the low beams.

For LED (option) and HID headlamps, the flash-to-pass operation will flash the high beams. The high beams will turn off immediately after the operation is

complete. Flash-to-pass does not affect the state of HID and LED low beams. Regardless of the headlamp type, if the vehicle is using high beams, flash-to-pass will immediately deactivate the high beams. The high beams must be reactivated again after flash-to-pass is complete.

To activate flash-to-pass:

1. Push the turn signal lever away from the steering wheel..

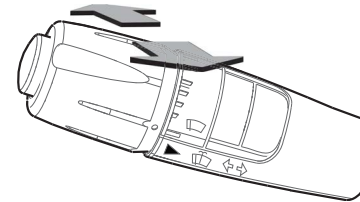

2. Release the turn signal lever to the original position.

Flash-to-Thank

Disposition: / Status:
Topic revised. Please review.

Flash-to-thank, or “marker lights flash”, allows the operator to signal other drivers by changing the state of the marker lights.

To activate flash-to-thank:

- Press the button at the end of the turn signal lever to invert the state of the marker lights

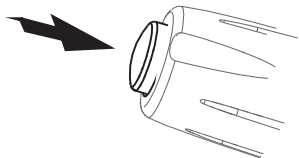

- Release the button to return to the original state of the marker lights.

Operate the Windshield Wipers

Disposition: / Status:
Researching updates to this topic per request.

This vehicle is equipped with a two speed, intermittent windshield wiper system. The windshield wiper system is integrated with the exterior lights so that the low beam headlights will turn on when the windshield wipers turn on.

WARNING

Clean blades regularly with a damp cloth to remove road film and wax

buildup. DO NOT drive with worn or dirty wiper blades. They can reduce visibility, making driving hazardous which may lead to an accident. Failure to comply may result in death, personal injury, equipment damage, or property damage.

CAUTION

DO NOT use antifreeze or engine coolant in the windshield washer reservoir, damage to seals and other components will result.

To override this function, turn the headlights on and then off again. Permanently overriding this functionality is attainable via the Settings Menu in the instrument cluster display. Go to **Settings > Wiper Interlock** and turn this value to OFF. Avoid running the wiper blades over a dry windshield to prevent scratching the glass. Spray on washer fluid first. A scratched windshield will reduce visibility. A seven-position rotary wiper switch (located on the turn signal lever) operates

the windshield wipers and washer. If you need to use the windshield wipers:

1. Rotate the end of the turn signal lever to change the wiper mode from off to on.
2. Rotate the outer knob of the turn stalk lever to adjust the wiper speed.

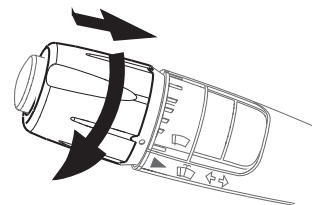

- Four levels of intermittent speeds
- Low wiper speed
- High wiper speed

How to Spray Windshield Washer Fluid

This vehicle is equipped with a function to wash the windshield and simultaneously engage the wipers.

3



CAUTION

If the electric pump is operated for a long period (more than 15 seconds) with a dry reservoir, the pump motor may be damaged.

If you need to use the windshield washer:

1. Push the **Turn Signal Lever Outer Knob** in.

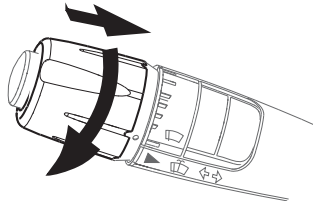

- Press and hold will activate the washer fluid and wipers.
- Instant press and release will activate the washer fluid only.

Door Mounted Mirror Controls

Disposition: / Status:

Topic was cloned from "bil1438106784498" for the removal of a note that was not applicable to MD. Please review.

If your vehicle is equipped with power mirrors, the mirror controls will be located on the driver-side door pad. Mirrors can be adjusted in four directions. To provide good visibility, adjust the mirror so the side of your vehicle appears in the inboard part of the mirror.

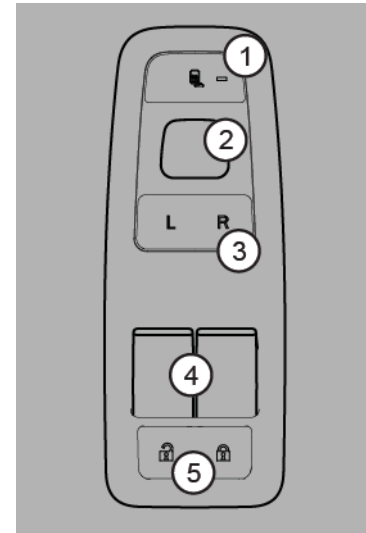

1. Mirror heat
2. Mirror adjust
3. Left or right mirror adjust selector
4. Window controls
5. Door lock control

Mirror Heat Switch

Your vehicle may be equipped with optional heated mirrors. Mirror heat is

controlled by the mirror heat switch button. If the vehicle has optional hood-mounted heated mirrors, this switch will also activate heat to those mirrors.

Power Mirror Switch

If your vehicle is equipped with power mirrors, the directional controls for both mirrors are located near the top of the driver-side door trim pad.

Power Door Lock Switch

Power door lock rocker switches are located on the door pads. To lock or unlock both cab doors as well as a sleeper door, depress any door lock switch at the end that displays a closed or open padlock symbol, respectively, on the switch face.

Power Window Switch

Power window rocker switches are located on the door pads. Depress the switch to open the window or pull up on the switch to close the window. Release the switch to stop window movement. The driver-side window has an express down feature. Pushing on the switch all the way down until the switch bumps will activate the express down feature. Release the button and the window will continue to open until it is completely open.

Introduction

Your vehicle comes equipped with two outside rear view mirrors that enable you to see to the sides and behind your vehicle. Be sure both mirrors are adjusted properly before you begin driving.

 **WARNING**

Adjust all mirrors before driving. Adjusting the mirrors while driving can cause you to take your eyes off the road, which could result in an accident. Failure to comply may result in death, personal injury, equipment damage, or property damage.

To provide good visibility, adjust the mirror so the side of your vehicle appears in the inboard part of the mirror.

 **WARNING**

Convex mirrors can distort images and make objects appear smaller and farther away than they really are. You could have an accident if you are too close to another vehicle or other object. Keep plenty of space between

your vehicle and others when you turn or change lanes. Remember that other objects are closer than they may appear.

How to Use Power Mirror Adjustment Switches

 **WARNING**

Adjust all mirrors before driving. Adjusting the mirrors while driving can cause you to take your eyes off the road, which could result in an accident. Failure to comply may result in death, personal injury, equipment damage, or property damage.

3

 **WARNING**

Convex mirrors can distort images and make objects appear smaller and farther away than they really are. You could have an accident if you are too close to another vehicle or other object. Keep plenty of space between your vehicle and others when you turn or change lanes. Remember that other objects are closer than they may appear.

1. Move the **Mirror Selector** switch (3) to the right or left from the neutral center position to select the desired mirror for adjustment.
2. Depress the **Mirror Directional Control** pad (2) in one of its four arrow directions to adjust the mirror in/out or up/down.
3. To provide good visibility, adjust the mirror so the side of your vehicle appears in the inboard part of the mirror.
4. After mirror adjustments have been completed, return the **Mirror Selector** switch back (3) to the center (neutral) position to prevent

unintentional adjustments to the mirrors.

Introduction

Your vehicle comes equipped with two outside rear view mirrors that enable you to see to the sides and behind your vehicle. Be sure both mirrors are adjusted properly before you begin driving.

 **WARNING**

Adjust all mirrors before driving. Adjusting the mirrors while driving can cause you to take your eyes off the road, which could result in an accident. Failure to comply may result in death, personal injury, equipment damage, or property damage.

To provide good visibility, adjust the mirror so the side of your vehicle appears in the inboard part of the mirror.

 **WARNING**

Convex mirrors can distort images and make objects appear smaller and farther away than they really are. You could have an accident if you are too close to another vehicle or other object. Keep plenty of space between your vehicle and others when you turn or change lanes. Remember that other objects are closer than they may appear.

Heating and Air Conditioning

This vehicle's heating and air conditioning system operates in four distinct modes: manual, automatic, semi-automatic, and maximum defrost. Each mode provides the driver with the greatest level of comfort and convenience.

The recommended mode for all conditions that do not require windshield defrosting is the automatic mode. This mode is capable of maintaining cab comfort under various driving conditions without driver interaction.

The cab heater and air conditioner controls are located together in the center of the dash just to the right of the steering column. The sleeper heater and air conditioner controls are located in the sleeper control panel.

 **WARNING**

DO NOT drive with visibility reduced by condensation or frost on the windshield. Your view may be obscured, which may result in property damage, personal injury, or death. For clear visibility and safe driving it is extremely important for you to follow the instructions pertaining to the function and use of the ventilation/heating and defogging/defrosting system. If in doubt, consult your dealer. Maximum heating output and fast defrosting can be obtained only after the engine has reached operating temperature. Failure to comply may result in death, personal injury, equipment damage, or property damage.

 **WARNING**

Exhaust fumes from the engine contain carbon monoxide, a colorless and odorless gas. DO NOT breathe the engine exhaust gas. A poorly maintained, damaged, or corroded exhaust system can allow carbon monoxide to enter the cab. Entry of carbon monoxide into the cab is also possible from other vehicles nearby. Failure to properly maintain your vehicle could cause carbon monoxide to enter the cab, resulting in personal injury or death.

 **WARNING**

Never idle your vehicle for prolonged periods of time if you sense that exhaust fumes are entering the cab. Investigate the cause of the fumes and correct it as soon as possible. If the vehicle must be driven under these conditions, drive only with the windows open. Failure to repair the source of the exhaust fumes may result in death, personal injury, equipment or property damage.

 **CAUTION**

DO NOT stay in the vehicle with the engine running or idling for more than 10 minutes with the vehicle's Heater and A/C ventilation system in RECIRC or at LOW FAN SPEED. Even with the ventilation system on, running the engine while parked or stopped for prolonged periods of time is not recommended.

 **NOTE**

Keep the engine exhaust system and the vehicle's cab ventilation system properly maintained. It is recommended that the vehicle's exhaust system and cab be inspected (1) By a competent technician every 15,000 miles (24,140 km); (2) Whenever a change is noticed in the sound of the exhaust system; or (3) Whenever the exhaust system, underbody, or cab is damaged.

CONTROLS - Heating and Air Conditioning

3

i NOTE

If you are required to idle your vehicle for long periods of time, install an auxiliary heater or automatic idle control.

These auxiliary devices can reduce fuel consumption and save you money.

i NOTE

If you are parked next to idling vehicles, move your vehicle or do not stay

in your vehicle for prolonged periods of time.

Air Conditioner Controls

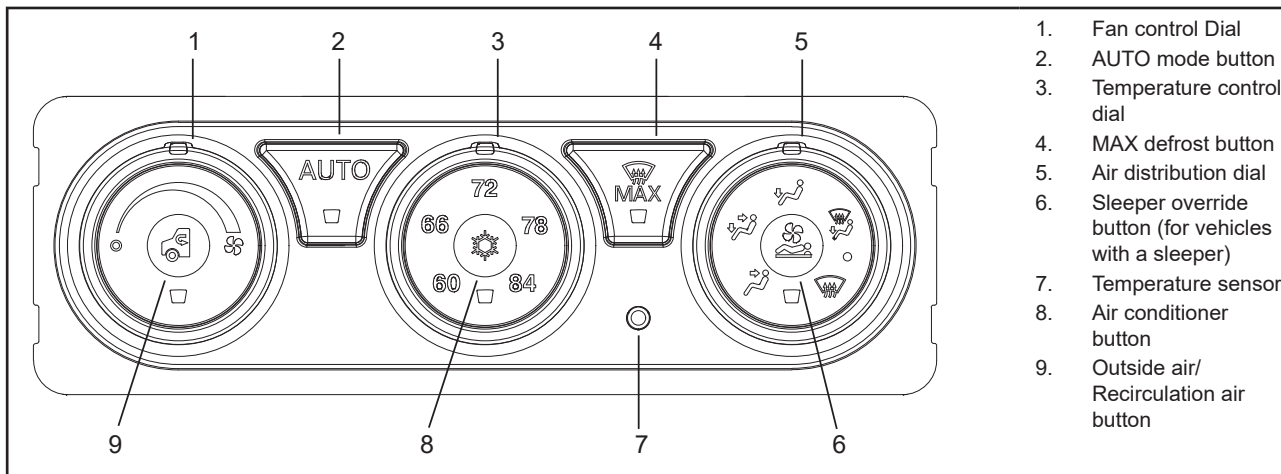

1. Fan control Dial
2. AUTO mode button
3. Temperature control dial
4. MAX defrost button
5. Air distribution dial
6. Sleeper override button (for vehicles with a sleeper)
7. Temperature sensor
8. Air conditioner button
9. Outside air/Recirculation air button

Air Conditioning Functions

Symbols for the air conditioning control panel

Image	Function
	The source of air entering the cab can be set to either outside air or recirculation air using the button inside the fan speed control dial. Recirculated air is automatically selected in defrost modes.
	The fan speed is adjusted by rotating the dial clockwise to increase speed or counterclockwise to decrease speed.
AUTO	Automatic air conditioner function
	The button inside the temperature control dial engages the A/C compressor. When

Image	Function
	activated the indicator on the button will illuminate. During AUTO mode, the A/C button indicator will remain illuminated at all times even though the compressor may be cycling.
	Max defrost function
	Power to the sleeper HVAC unit can be toggled using the button inside the air distribution dial. When activated, the indicator on the button illuminates. The sleeper HVAC unit will function to the settings of the sleeper control.
	Floor Vents
	Defrost Vents (and Fresh air intake)

Image	Function
	Panel and Floor Vents
	Panel Vents
	Floor and Defrost Vents (and Fresh air intake)

How to Manually Control the Cab Air Conditioner

Disposition: / Status:
Grammar mistakes fixed.

Temperature Control Set Point	The cab temperature is set using the temperature control dial. The operating range is 60°F (16°C) and 84°F (28°C). Adjustments are made in two degree Fahrenheit increments.
Air Conditioner	The button inside the temperature control dial engages the A/C compressor. When activated the indicator on the button will illuminate. During AUTO mode, the A/C button indicator will remain illuminated at all times even though the compressor may be cycling.

3

i NOTE
 Fan Control Dial must also be in the ON position for A/C to be on. A/C engages automatically in AUTO, defrost, and floor/defrost.

The air conditioner defaults to Manual mode when turned on. The fan speed, air temperature, and air outlets are selected using the dials on the controller.

1. To adjust the fan speed, turn the **Fan Control** dial clockwise to increase speed or counterclockwise to decrease speed.
2. To adjust the temperature setting, turn the **Temperature Control** dial to the desired temperature. The system automatically adjusts the outlet air temperature to achieve the desired cab temperature.
3. Push the **Air Conditioner** button if the air temperature needs to be colder, this button will manually turn on the compressor.



4. To adjust the air distribution, turn the **Air Distribution** dial to distribute cab air as indicated by the dial graphics.
5. Press the **Recirculation** button to use cab air instead of outside air.



The temperature of the air from the vents will fluctuate as the vehicle works to achieve the chosen cab temperature. When idling for short periods of time, keep the fan ON and turn OFF **recirculation**. For vehicles with a sleeper, the cab control can be used to activate/deactivate the sleeper HVAC using the button inside the mode dial.

Auto Mode for the Air Conditioner

The Auto Mode will manipulate the air distribution, air temperature, fan speed, A/C compressor, and cab air recirculation to achieve the comfort level selected on the temperature dial. Depending on the specific environmental conditions, the air temperature can be slightly higher or lower than the set point. This is a normal function of the AUTO mode and is not to be mistaken for a malfunctioning system. The

button that enables automatic mode is labeled **AUTO**.

AUTO

Disposition: / Status:
 "driver adjusts both the fan speed and air distribution dials on the control" added, per SME request. Please review.

Adjust the temperature knob, and the system will respond to obtain the selected comfort level as quickly as possible.

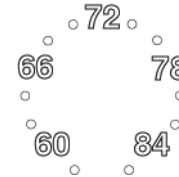

The cab temperature is set using the temperature control dial. The operating range is 60°F (16°C) and 84°F (28°C). Adjustments are made in two degree increments.

The AUTO function uses a sunlight sensor to measure the amount of sunlight entering the cab. This sensor is located at the base of the windshield on the driver's side of the instrument panel. Do not block this sensor.

The system will remain in automatic mode until the driver adjusts both the fan speed and air distribution dials on the control.

Semi-Automatic Mode

During AUTO mode, the operator may override any setting and operate in a semi-automatic mode. This can be done via the dials and/or buttons on the HVAC control. In Semi-automatic mode, the AUTO button indicator will cease to be illuminated. Instead, the indicator of the adjusted setting will illuminate. For example, if the driver adjusts the fan dial while in AUTO mode, the fan dial indicator will illuminate and fan speed will adjust to the setting of the dial. However, the temperature and air outlet settings will continue to function automatically. Similarly, if user adjusts the air distribution setting while in AUTO mode, the air distribution dial indicator will illuminate and the distribution will adjust to the setting of the dial. The fan and temperature settings will continue to function automatically.

Economy Function

An economy function is also available in Semi-automatic mode. In this mode, the system will operate in AUTO mode without the use of the A/C compressor. The

operator may select economy by initiating AUTO mode and then pressing the A/C button to disengage the compressor. The indicators for A/C compressor and AUTO mode do not illuminate while operating in economy mode.

How to Operate Automatic Cab Air Conditioner

Follow these steps to activate the Auto Mode:

1. Press the **AUTO** button.
2. Rotate the **Temperature Control** dial to the desired temperature.

The system will achieve the comfort level associated with the temperature selected. Cab temperature can be slightly higher or lower than the selected temperature, which is a normal when in **AUTO** mode and should not be mistaken for a system malfunction.

MAX Defrost Mode

The heating and air conditioning system provides for one touch windshield defrosting. Certain driving conditions will cause fog or ice to form on the windshield. By pressing the **MAX** defrost button, the system will automatically adjust the blower

speed, recirculation, air temperature, and air outlet distribution to maximize clearing of the windshield. The system will remain in this mode until the driver presses the button again or adjusts the dials.



Disposition: / Status:
Additional information added to last sentence. Please review.

The air temperature in MAX defrost mode will be set to the warmest temperature setting. This setting helps to clear the windshield of ice and fog more quickly. Outside air mode and the air conditioner compressor are also active to maximize performance. The A/C compressor and recirculation switches are disabled in MAX Defrost, and the lights on those switches will blink if pressed.

Air Conditioner Operating Tips



CAUTION

During extreme cold weather, DO NOT blow hot defroster air onto cold windshields. This could crack the glass. Turn the Air Flow Control Dial to Defrost and adjust the fan speed accordingly while the engine warms. If the engine is already warm, move the Temperature Control Dial to "cool," then gradually increase the temperature when you see that the windshield is starting to warm up. Failure to comply may result in equipment damage.

Defrosting and Defogging the Windshield

The cab windshield and side windows can be cleared of ice and fog in two ways. The first is to use the **MAX** defrost mode. The second is to manually adjust the air distribution dial to the defrost position. The manual defrost/defogging mode differs from the **MAX** defrost mode by allowing the driver to select an air temperature other than full heat. This allows the driver to maintain a constant cab temperature while

defrosting the windshield. However, note that performance may be reduced.

- Adjust the fan speed to high by rotating the fan control dial clockwise.
- Set the air distribution dial to the defrost mode setting. This automatically engages the outside air and the air conditioner compressor.
- Adjust the temperature dial to add heat as needed.

For maximum performance, adjust the temperature to maximum heat by rotating the temperature dial clockwise. The driver may also use the floor/defrost setting on the air control

For Maximum Cooling

- Adjust the fan speed to high by rotating the fan control dial clockwise.
- Set the air distribution dial to the panel setting.
- Adjust the air temperature to maximum cool by rotating the temperature dial counterclockwise.
- Engage the air conditioner compressor by pressing the air conditioner button.

- Set the air source to recirculation mode by pressing the outside air/recirculation air button. The button indicator light should be illuminated.

For Maximum Heating

- Adjust the fan speed to high by rotating the fan control dial clockwise.
- Set the air distribution dial to the floor setting.
- Adjust the air temperature to maximum heat by rotating the temperature dial clockwise.



NOTE

The engine must be at operating temperature for maximum heating. If operating in AUTO mode, heating airflow is not allowed until the engine warms sufficiently to provide required coolant temperatures.

Air Dehumidification

The air conditioner system can be used to reduce the humidity level of the cab and clear fog from the windshield.

- Adjust fan speed to the desired airflow setting.
- Engage the air conditioner compressor by pressing the air conditioner button.
- Set the air source to outside air mode by pressing the outside air/recirculation air button. The button indicator light should NOT be illuminated.

i NOTE
The A/C compressor may not engage when the outside temperature is below 34°F (1°C).

Cab Air Distribution

Equal distribution of air is important in maintaining a constant cab interior temperature. For best performance, all vents should remain open to allow AUTO mode to function properly. To maintain the selected cab temperature, AUTO mode may provide an air temperature from the vents that differs from the temperature set point. To ensure proper operation, it is recommended that the driver redirects the air instead of adjusting the temperature set point or closing the vent. The system may

have difficulties in obtaining the desired cabin temperature if the temperature setting is repeatedly changed. The mode of air distribution inside the cab is set using the air distribution dial. Five icons on the dial indicate the primary mode options. The driver may also select a secondary mode in between the primary modes indicated by points on the dial. Airflow is provided to the side windows in all modes.

Outside Air/Recirculation Air

Selecting air recirculation mode completely isolates the cab interior from the outside air. This mode is helpful in preventing dust, pollen, and odors from entering the cab. Additionally, recirculation mode can reduce the amount of time needed to cool down the vehicle while in maximum cool down. Note that the mode may increase fogging on the windshield. A coarse air filter is provided for recirculation air and is located under the instrument panel. The outside air mode provides for 100% outside air into the cab. This mode is helpful with windshield defogging. A pleated air filter located under hood provides filtration for dust, pollen, and debris. If equipped, your vehicle may also provide for ember filtration or fine particulate filtration.

Cab Accessories

i NOTE
The 12V accessory power port will operate with the ignition key in either the OFF, ACC (accessory), or ON position.

This vehicle comes standard with two cupholders and power ports located in the center of the dashboard. This vehicle may contain a variety of optional cab accessories. Electrically powered cab accessories, such as the stereo system, can be used when the ignition switch is in the ACC position and can be affected by the Low Voltage Disconnect (see Low Voltage Disconnect).

Radio Stereo System (option)

Your vehicle has one of two stereo systems. An AM/FM Stereo Receiver is standard equipment and may have a combination of CD, Satellite Radio, USB media, or Bluetooth. A stereo system integrated with GPS navigation and telematics is also available (option). For instructions on how to operate your

3

particular radio, see the supplemental operating manual for those units. Controls for the infotainment system are located on the Right Switch Pod of the steering wheel.

Air Horn (Option)

Your vehicle may be equipped with optional air horns. To operate, pull on the lanyard extending from the overheard panel on the driver's side.

Dual USB Charger

This vehicle comes standard with dual USB 5V charging ports. Both USB ports are 5V, USB-A type connections.

Cigarette Lighter and Ashtray (Option)

This vehicle may have the optional ashtray insert (for the cupholder) and the optional cigarette lighter instead of a power port. To operate, push in on the knob end of the lighter. After a few moments, the lighter will automatically pop out, glowing hot and ready to use. After use, insert the lighter back into the socket without pushing all the way in. The socket of the cigarette lighter may be used to operate 12V, 15 amp

appliances, such as a hand spotlight or small vacuum cleaner.

 **WARNING**

Do not attempt to operate a cigarette lighter using the 12V power port receptacle. A cigarette lighter inserted into the 12V power port will heat up and be expelled into the cab, potentially causing fire. Failure to comply may result in death, personal injury, equipment damage, or property damage.

 **WARNING**

DO NOT place paper or other combustible substances in an ashtray, it could cause a fire. Keep all burnable materials, besides smoking materials, out of the ashtray. Failure to comply may result in death, personal injury, equipment or property damage.

 **WARNING**

DO NOT exceed the voltage/ampere capacity of the accessory power

port. It could result in a fire. Follow all warnings and instructions in the operator's manual for the appliance you are using. Failure to comply may result in death, personal injury, equipment or property damage.

Glove Box

A glove box is provided to store important documents, the vehicle literature set (including this Operator's Manual), and other related materials. You can choose from a variety of other interior storage options to store your personal supplies or small tools:

- Center console
- Map pocket on the door
- Overhead storage compartments

 **WARNING**

DO NOT drive with the glove box open, it can be dangerous. In an accident or sudden stop, you or a passenger could be thrown against the cover and be injured. To reduce the risk of personal injury during an accident or sudden stop, keep the glove box closed when the vehicle is in motion.

 **WARNING**

DO NOT carry loose objects in your cab, it can be dangerous. In a sudden stop, or even going over a bump in the road, they could fly through the air and strike you or a passenger. You could be injured or even killed. Secure all loose objects in the cab before moving the vehicle. Carry any heavy objects such as luggage in the exterior storage compartment and close it securely.

Dome Light

Interior cab lighting is controlled using the three-position, overhead, dome light switch:

- On – Turns on the center, overhead dome light and both the left and right map lights.
- Center Position – Turns on the overhead dome light when either cab door is open, or when the doors are unlocked using the key fob.
- Off – Turns off the center, overhead cab light and disables both the left and right map lights.

The wash down, ambient lighting is controlled using the dimmer switch (see [Lights, Cab and Panel Dimmer Switch](#) on page 96).

Appliances

If your vehicle is equipped with a television or other appliance, be sure they are compatible with your vehicle's electrical system. Secure them in the cab so they cannot come loose during a sudden stop.

 **WARNING**

In a sudden stop or collision a heavy object in your cab could strike you or anyone with you. You could be injured or even killed. Secure any appliance (such as a radio, or TV) you add to your sleeper or cab.

Vehicle Telematic System

Your vehicle may be equipped with an onboard telematics system. This system is a Global Positioning Satellite (GPS)-linked computer. It receives input from multiple sources to locate your vehicle. Read and understand the Supplemental Telematics and Navigation System Owner's Manual and observe the Warnings, Cautions, and Notes that follow before using the system.

3

 **WARNING**

Verify legal weight and height restrictions for the route suggested by the telematic system. Failure to verify height restrictions could lead to causing death, personal injury or property damage. Failure to verify weight restrictions could result in a traffic infraction.

 **WARNING**

Only glance at the system monitor while driving. Prolonged periods of viewing while driving could result in an accident involving death or personal injury.

 **WARNING**

DO NOT program the telematic system while driving. Always stop your vehicle when programming or changing the settings on the telematic system. Programming the system while driving can cause you to take your eyes off

the road, which could result in an accident involving death, personal injury or equipment damage.

 **WARNING**

Regardless of how and where the navigation system directs you, it is your responsibility to operate the vehicle in a safe and legal manner. Failure to comply may result in death, personal injury, equipment or property damage.

 **WARNING**

Ensure the volume level of all audio devices is set to a level that still allows you to hear outside traffic and emergency vehicles. Failure to comply may result in death, personal injury, equipment or property damage.

 **CAUTION**

DO NOT rely on the telematic system to route you to the closest emergency

services. Not all emergency services are in the database.

 **NOTE**

The map database is the most current available at the time of production. The database is designed to provide you with route suggestions and does not take into account the relative safety of a suggested route or of factors that may affect the time required to reach your destination. See the Supplemental Navigation System Owner's Manual for more information.

Using the Telematic System

Screen Display On/Off

1. Press and hold the **POWER/LIGHT** button for approximately 1 second.
2. After the display has been turned on, the following Warning/Informational screen will appear.

Warning/Informational Screen

<p>WARNING</p>  <p>DO NOT let this device distract you while driving. Always concentrate on your driving. Distractions could cause an accident resulting in injuries to you or others.</p>
<p>IMPORTANT</p>
<p>Disclaimer: Map data may be inaccurate and navigation routes may not be available for larger size vehicles. Regardless of how and where the navigation system directs you, it is your responsibility to operate the vehicle in a safe and legal manner. Note: Before using this system, read the Owner's Manual and learn how it operates. Some functions of this system will not</p>

<p>WARNING</p>  <p>DO NOT let this device distract you while driving. Always concentrate on your driving. Distractions could cause an accident resulting in injuries to you or others.</p>
<p>operate when the truck is moving.</p>

3. After reading the information, touch the **T** in the upper right corner of the screen with your finger indicating you acknowledge and understand the information. The **MENU** screen will automatically appear next.
4. To turn the system off, press and hold the **POWER/LIGHT** button for 3 seconds.
Disclaimer: The vehicle manufacturer is not responsible for erroneous map data, misrouting or any downtime or other damages associated with or arising out of the use of the Navigation System.

Chapter 4 | DRIVING

4

Starting and Operating.....	125
Lighting Controls.....	131
Engine Operations.....	133
Transmission.....	140
Air Brake System (option).....	144
Brake Safety and Emergency.....	150
Retarders.....	153
Axle and Suspension.....	156
Fifth Wheel.....	166
Driving Tips and Techniques.....	171
Stopping the Vehicle.....	173
Anti-Lock Brake Systems (ABS).....	175

Starting and Operating

For detailed information on starting and operating the engine, refer to the Engine Operation and Maintenance Manual provided with your vehicle.

Since each vehicle is custom-equipped, all engine operation instructions in this manual are general. You will want to consult the manual for your engine to find out details about your specific engine's needs. You may need to use a slightly different procedure from the one outlined here.

Also, read the American Trucking Association's (ATA) Truck Driver's Handbook. It will give you tips on starting, shifting, and driving your vehicle.

This section includes instructions for both Normal Temperature starting and Cold Weather starting. The engine type (brand) and size determines what type of cold weather starting aid is installed in your vehicle. Refer to your Engine Operation and Maintenance Manual to learn what precautions you should take before starting the engine. Many new electronic engines cannot use ether or other starting fluids. These engines are equipped with a resistive grid heating system. See *Tips to*

Remember When Starting Vehicle in Cold Weather on page 126.



WARNING

Disposition: / Status:
Updated Warning.

Using starter fluid to start the engine may result in fire or explosion. Do not use starter fluid. Failure to comply may result in death, personal injury, equipment damage, or property damage.



WARNING

NEVER start or let the engine run in an enclosed, unventilated area. Engine exhaust fumes contain carbon monoxide, a colorless and odorless gas. Carbon monoxide can be fatal if inhaled. Failure to comply may result in property damage, personal injury, or death.



WARNING

Disposition: / Status:

Altered Warning. Please review before publication.

Do not park or operate the vehicle in areas where the hot exhaust system may come in contact with dry grass, brush, spilled fuel, or other material that can cause a fire. Failure to comply may result in death, personal injury, equipment damage, or property damage.

How to Start Vehicle in Normal Weather



CAUTION

Never operate the starter motor while the engine is running. The starter and flywheel gears could clash or jam, severely damaging them.

4

i NOTE
Some starters are equipped with over-crank protection. Check the Engine Operation and Maintenance Manual for details.

When the outside temperature is above 50°F (10°C), you can use the following procedure. If Anti-Theft is enabled, the first time you turn the ignition switch to START, you will need to enter the Passcode.

1. Set the parking brake.
2. Put your main transmission in Neutral.
3. Disengage (depress) the clutch (with manual transmission).
4. Turn the ignition switch to START.

i NOTE
If Anti-Theft is enabled, you will need to enter the Passcode in order to start the engine (see [Anti-Theft](#) on page 56).

5. If the engine does not start within 30 seconds, release the ignition switch. To avoid overtaxing the

starter motor or the batteries, don't use the starter for more than 30 seconds. Let the starter motor cool and the batteries recover for two minutes before trying again. If the engine still won't start after a couple of tries, check the fuel lines for possible fuel starvation or air leaks. Starting failure may mean fuel is not reaching the injectors.

6. As soon as the engine starts, begin to watch the oil pressure gauge. Check your engine manufacturer's manual for the right pressure for your engine. If the oil pressure doesn't rise within a few seconds, stop the engine. Find out what is wrong before restarting the engine.
7. Slowly engage (release) the clutch after the engine has started.
8. Wait for the oil pressure gauge to reach normal operating pressure before operating the vehicle or idling faster than 1,000 rpm.

Tips to Remember When Starting Vehicle in Cold Weather

If you follow a few simple guidelines, you will extend the service life of your engine:

- Keep the electrical system in top condition.
- Use the best quality fuel of the recommended grade.
- Use recommended engine lubricating oil.
- For manual transmissions and auxiliary transmissions, leave the transmission in neutral and allow the transmission lubricating oil to warm up (approximately 3-5 minutes) before operating vehicle.

Engine Block Heater (Option)

PACCAR has many variants of block heater harnesses. If needed, work with your dealer if you require assistance identifying the block heater equipment. The on-vehicle connection port configuration also helps identify voltage, current, and usage requirements. To preheat the engine before starting, plug the engine block heater into a properly grounded AC electrical source. **DO NOT** start the engine with the heater plugged in.

 **WARNING**

Engine block heaters can cause fires which may result in property damage, personal injury, or death if not properly maintained and operated. Regularly inspect the engine block heater wiring and connector for damaged or frayed wires. DO NOT use the heater if there are any signs of problems. Contact your authorized dealer or the manufacturer of the heater if you are in need of repairs or information.

 **CAUTION**

Always unplug heater before starting the engine. Damage to the cooling system could occur if the heater is not turned OFF (unplugged).

 **CAUTION**

Always unplug heater before starting the engine. Damage to the cooling system could occur if the heater is not turned OFF (unplugged).

Disposition: / Status:
Do all Warning and Caution statements need to be conrefs?

 **WARNING**

Ensure all components of the shore connection (cord, outlet, power source, timer, hookup panel, fuses, etc.) meet or exceed the load requirements of the engine block heater (element and harness). Failure to comply may result in equipment damage, bodily injury, or death.

Consider the length of cord required to connect the block heater to shore power. Longer runs require heavier gauge cords. It is recommended to use a 10-AWG cord for up to 100 ft. Connect the cord to the block heater first, then plug the cord into the supply outlet. If a longer cord is needed, consult your local electrical codes, and use the recommended AWG cord for a 20-amp load. PACCAR uses both 110 and 220 volt engine block heaters. Make sure to reference the correct voltage if you need a longer cord.

Safe practice tips:

- Know your truck's requirements
- Ensure all components of shore power connection meet requirements
- Use a thermostat or timer to limit overuse
- Allow sufficient time for warmup
- Safely route cord and position as a reminder to disconnect if possible
- Always disconnect the block heater from shore power before starting the engine

4

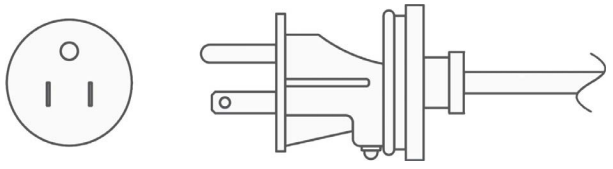
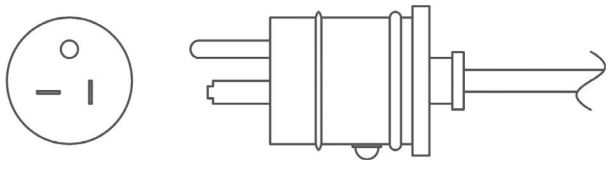
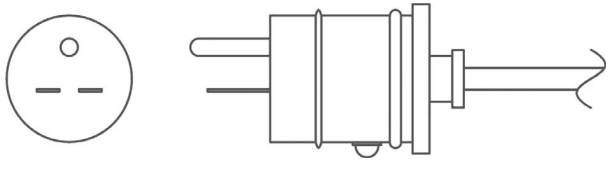
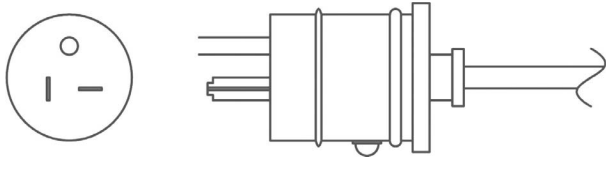
Configuration	Voltage	Amperage	Wattage
	120	15	0-1700
	120	20	1701-2400
	240	15	0-3300
	240	20	3301-4800

Engine, Under Hood Air Intake

This switch opens a door in the engine air filter housing so that the air is taken from under the hood instead of outside air. This switch can be useful when starting the vehicle in cold weather conditions.



CAUTION

Only operate the under hood intake air switch when outside temperatures are below 32°F (0°C). Engaging the under hood air intake while temperatures are above freezing may result in engine damage.

Bulb Check

When the ignition switch is turned ON multiple warning icons will be displayed in a sequence to test each warning light indicator. The total sequence should take no more than 10 seconds to complete. Have your instrumentation system checked

by a qualified service technician if it does not successfully complete.

Audible Alarm

The audible alarm will sound in conjunction with most warning lights. These events include but are not limited to headlight on, fifth wheel, stop engine, primary/secondary air, and driver door open warnings.

Optional Icons

Additional icons may be operational depending on individual vehicle specifications.

NOTE

Some optional lights may illuminate even though your vehicle is not equipped with that particular feature.

Engine Warm Up

Engine warm-up allows oil film to be established between pistons and liners, shafts and bearings while your engine gradually reaches operating temperature.

1. After you've started your engine, idle it at approximately 600 rpm while you check:
 - Oil pressure
 - Air pressure
 - Alternator output
2. After a few minutes of idling at 600 rpm, increase your idle speed to 900 or 1,000 rpm. Continue your warm-up. This procedure allows oil to warm and flow freely while pistons, liners, shafts, and bearings expand slowly and evenly. In extremely cold temperatures, you may have to increase idle speed.

NOTE

In colder climates where the temperature is often below freezing, the warm-up for turbocharged engines is especially important. Chilled external oil lines leading to the turbocharger will slow the oil flow until the oil warms, reducing oil available for the bearings. Watch the engine oil temperature or pressure gauge for a warming trend before increasing engine idle speed (rpm).

4

- Continue the engine warm-up until the coolant temperature reaches at least 130°F (54°C). At this temperature, you can use partial throttle. Wait until the coolant temperature is at least 160°F (71°C) before operating at full throttle.

i **NOTE**

Under most circumstances, idling your engine for long periods merely wastes fuel. In severe arctic weather conditions, however, you may need longer idling to be sure all parts of your engine are fully lubricated.

! WARNING

Exhaust fumes from the engine contain carbon monoxide, a colorless and odorless gas. DO NOT breathe the engine exhaust gas. A poorly maintained, damaged, or corroded exhaust system can allow carbon monoxide to enter the cab. Entry of carbon monoxide into the cab is also possible from other vehicles nearby. Failure to properly main-

tain your vehicle could cause carbon monoxide to enter the cab, resulting in personal injury or death.

! WARNING

Never idle your vehicle for prolonged periods of time if you sense that exhaust fumes are entering the cab. Investigate the cause of the fumes and correct it as soon as possible. If the vehicle must be driven under these conditions, drive only with the windows open. Failure to repair the source of the exhaust fumes may result in death, personal injury, equipment or property damage.

! WARNING

To reduce the chance of personal injury, vehicle damage and/or death from overheated engines, which can result in a fire, never leave the engine idling without an alert driver present. If the engine should overheat, as indicated by the engine coolant temperature light, immediate action is required to correct the condition. Continued unat-

tended operation of the engine, even for a short time, may result in serious engine damage or a fire. Failure to comply may result in death, personal injury, equipment or property damage.

! CAUTION

The use of a winterfront can result in excessive coolant, engine oil, and intake air temperatures, which may lead to overheating and possible engine damage.

! CAUTION

DO NOT allow your engine to idle, at low rpm (400-600 rpm), longer than five minutes. Long periods of idling after the engine has reached operating temperatures can decrease engine temperature and cause gummed piston rings, clogged injectors, and possible engine damage from lack of lubrication. The normal torsional vibrations generated can also cause transmission wear.

i NOTE

Keep the engine exhaust system and the vehicle's cab ventilation system properly maintained. It is recommended that the vehicle's exhaust system and cab be inspected (1) By a competent technician every 15,000 miles (24,140 km); (2) Whenever a change is noticed in the sound of the exhaust system; or (3) Whenever the exhaust system, underbody, or cab is damaged.

i NOTE

If you are parked next to idling vehicles, move your vehicle or do not stay

in your vehicle for prolonged periods of time.

How to Warm Up the Transmission

In cold weather (below 32°F (0°C)), you may find shifting sluggish when you first start up. Transmission warm-up is especially important at this time, but it is always a good idea to warm-up your transmission before starting out on the road.

To warm-up the transmission lubricating oil during engine warm-up, with a single transmission (manual and automatic):

1. Put the transmission in Neutral.
2. Release the clutch pedal (manual only) and operate the transmission in neutral for 3 to 5 minutes prior to

operating the transmission in either forward or reverse range.

3. If you have a two-transmission combination:
 - a. Put the main transmission in gear.
 - b. Put the auxiliary transmission in Neutral. This will allow the transmission countershaft to turn, agitating the oil and warming it.

Lighting Controls

Lighting Switches

4

Exterior Lights Switch (ELS)

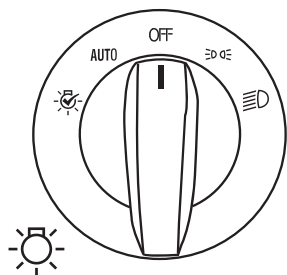

Hazard Warning

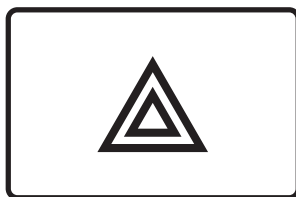

Cab and Panel Dimmer

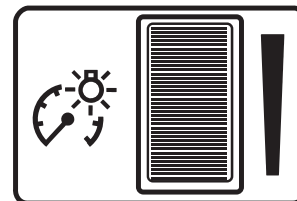

Cab and Panel Dimmer

Changes the brightness of the instrument panel lights. See [Lights, Cab and Panel Dimmer Switch](#) on page 96).

Exterior Lights Switch (ELS)

Five-position rotary switch that controls which exterior lights are active and can also start an Exterior Lights Self Test (ELST). See Exterior Lights Switch.

Hazard Lights

Turns on Hazard Warning Lights. See [Lights, Hazard](#).

Optional Lighting Switches



[Lights, Beacon](#) on page 96.



Lights, Daytime Running (Override) on page 96.



Lights, Fog on page 100.



Lights, Spot on page 100.



Lights, Work on page 100.

Headlight flashing

Disposition: / Status:

Revised section. Please review.

- **Flash-to-Warn** (or High Beams Flash) - Warn other drivers by briefly activating high beam headlights. See *Flash-to-Warn* on page 107.
- **Flash-to-Pass** (sometimes called Low Beams Flash) - Signal other

drivers by briefly changing headlight intensity. See *Flash-to-Pass* on page 108.

- **Flash-to-Thank** (or Marker Lights Flash) - Signals other drivers by briefly flashing the marker lights. See *Flash-to-Thank* on page 108.

Engine Operations

PTO Operations (option)

This truck may be equipped with Power Take-Off (PTO). PTO operation is enabled by using the dash mounted PTO switch in conjunction with the cruise control feature. When enabled, the tachometer will represent PTO operation, and may display the following additional PTO related information:

- Engine RPM – indicated near the tachometer as well as on the scale line.
- PTO hours – shows engine hours used during PTO activity.
- DPF Status – shows Diesel Particulate Filter usage as a percentage.

- Engine Torque – shows the percentage of max engine torque being exerted.

Dependent on your engine these modes can be read inside the tachometer. For more information on PTO operation see *How to Start the PTO* on page 133, *How to Stop the PTO* on page 134, and/or consult your PTO manufacturer's operating instructions.

How to Start the PTO

Disposition: / Status:

Researching updates to this topic per request.

The PTO operation can be enabled and activated in many different ways. Refer to your PTO manufacturer's Operating Instructions for specific guidance on how to operate the PTO. The information below provides the basic process of enabling and activating PTO and what the operator should observe during this process; however, defer to your PTO manufacturer's Operating Instructions in all cases where there is a disagreement in instruction.

4

 **CAUTION**
 Increasing engine rpm before the PTO is engaged can prevent the PTO from engaging and/or cause PTO damage.

 **NOTE**
Disposition: / Status:
 Altered note. Please review before publication.
 Actual PTO engagement/disengagement can be momentarily delayed.

 **NOTE**
Disposition: / Status:
 New Note. Please review before publication.
 Individual PTO activation and operation depends largely on the power source of the PTO as well as the transmission or engine configuration. Seek out appropriate transmission or engine operator's manual for additional information.

1. Toggle the **PTO ON/OFF** switch to the ON position. Text indicating PTO engagement will appear at the center of the display. Depending on configurations, some Vehicles with PACCAR transmissions will display the letters **AN** in the transmission gear indicator.
2. Press the Cruise Control (CC) **ON/OFF** button to enable PTO speed control operations. A white speed control enabled icon will appear
3. Press the **SET +** and **RES –** Cruise Control (CC) buttons to command a desired engine speed. PTO Speed Control is now active.
4. To increase or decrease PTO engine speed use a combination of short and long presses of the **SET +** and **RES –** Cruise Control (CC) buttons.

PTO speed indicates on the digital tachometer and below it, as a numerical readout.

How to Stop the PTO

Disposition: / Status:
 Altered topic. Please review before publication.

When PTO Speed Control is active, there are many ways to disable it depending on how the vehicle is configured.

- Tap the service brake
- Engage the clutch
- Turn Cruise Control Off
- Release the Parking Brake - (This is applicable only if PTO was activated while the truck was stationary.)
- Toggling the **PTO switch** to OFF

In some PTO configurations, Cruise Control switches will continue to control engine speed even after the PTO switch is turned off. It is not advised to stop the PTO when engine speed is above the default setting. Remember, to quit PTO operations fully, toggle the **PTO switch** to OFF.

Engine Fan Control

The engine fan switch on the dash has a manual and an automatic mode. In the manual mode, the engine fan will engage until the switch is back into automatic mode. In automatic mode, the engine fan operation is controlled by the engine computer.

 **WARNING**

DO NOT work on or near the fan with the engine running. Anyone near the engine fan when it turns on could be injured. If it is set at MANUAL, the fan will turn on any time the ignition key switch is turned to the ON position. In AUTO, it could engage suddenly without warning. Before turning on the ignition or switching from AUTO to MANUAL, be sure no workers are near the fan. Failure to comply may result in death or personal injury.

 **CAUTION**

DO NOT operate the engine fan in the MANUAL position for extended periods of time. The fan hub was designed for intermittent operation. Sustained operation will shorten the fan hub's service life as well as reduce fuel economy. Failure to comply may result in equipment or property damage.

 **CAUTION**

The fan or equipment near it could be damaged if the fan turns on suddenly when you do not expect it. Keep all tools and equipment away from the fan. Failure to comply may result in equipment or property damage.

Using a Winterfront

 **CAUTION**

The use of a winterfront can result in excessive coolant, engine oil, and intake air temperatures, which may lead to overheating and possible engine damage.

 **CAUTION**

A winterfront should only be used at temperatures below 40°F (4°C). Use of a winterfront above 40°F (4°C) can decrease life of cooling module components. Remove winterfront as soon

as the ambient temp reaches 41°F (5°C). The use of a winterfront above 40°F (4°C) can result in excessive coolant, engine oil, and intake air temperatures, which may lead to overheating and possible engine or coolant module damage and emissions non-compliance.

The winterfront is designed to minimize the temperature differences across the radiator and reduce the possibility of cooling module damage. Aftermarket winterfronts may not provide the proper airflow distribution and could cause cooling module damage.

Engine Aftertreatment System

This vehicle has an engine aftertreatment system (EAS) to control vehicle exhaust emissions. The EAS consists of the following:

- Diesel Particulate Filter (DPF)
- Selective Catalytic Reduction (SCR)
- Diesel Exhaust Fluid (DEF) filter
- DEF coolant filter
- DPF switch
- Warning lights

4

The DPF will trap soot from the engine exhaust gases. The SCR uses Diesel Exhaust Fluid (DEF) to reduce the levels of Nitrogen Oxides (NOx) in the engine exhaust. The EAS will periodically clean (regenerate) the DPF. Please refer to the Engine Aftertreatment System Supplement provided with the vehicle for a more detailed description of functionality and warnings.

Cruise Control

Disposition: / Status:
Researching updates to this topic per request.

 **WARNING**

Disposition: / Status:
Changed Warning. Please Review.

DO NOT use a retarder (engine brake, exhaust brake, or transmission retarder) when operating on road surfaces with poor traction (such as wet, icy, or snow covered roads, or gravel). Retarders can cause the wheels to skid on a slippery surface. You could lose control of the vehicle or jackknife if the wheels begin to skid, resulting in an

accident. Failure to comply may result in death, personal injury, equipment damage, or property damage.

 **WARNING**

DO NOT use a retarder (engine brake, exhaust brake, or transmission retarder) in heavy traffic. Most retarders slow the truck without activating the brake lights, which would not alert a closely-following vehicle that the truck is slowing. This could result in a rear end collision resulting in death, personal injury, equipment damage, or property damage.

Disposition: / Status:
TX-18 transmission was removed. Also, "dashboard" location was added since that is the standard location for MD. Please review before publication.

Cruise control functions and features may vary depending upon which engine you have. For a specific explanation of your cruise control, see the cruise control or engine manual included with your vehicle. This vehicle's electronic system will perform a 'rationality check' every time the

vehicle is started. This check is to ensure that the service brakes are working before allowing cruise control to function. This safety feature is designed to ensure that a driver is able to cancel the cruise set speed by using the service brake pedal. The system will not allow cruise control operation if it does not pass the 'rationality check.' The display will prompt you to press the service brake pedal if it has not been pressed since the vehicle has been started. In vehicles with PACCAR TX-12 or Eaton Endurant transmission, the cruise control switches may be located on the dashboard or on the shift control knob.

The left switch pod on the steering wheel contains buttons for the cruise control.

Left Switch Pod

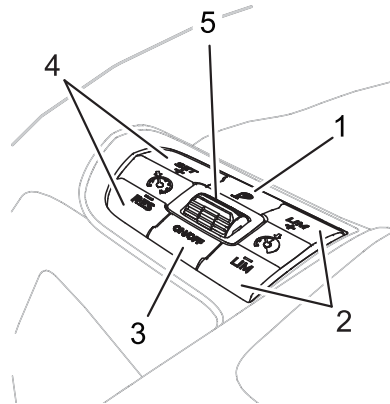

1. **Trip**
2. Variable Road Speed Limiter (VRSL) **LIM+** and **LIM-** (option)
3. Cruise Control **ON/OFF**
4. Cruise Control (CC) **SET+** and **RES-**
5. **Toggle**

The switches on the left side of horn pad manage vehicle speed functions like cruise control and variable road speed limiter

(option). If the vehicle has adaptive cruise control (option), predictive cruise control (option), etc., the toggle switch is also used to operate that system.

How to Set Cruise Control Speed

Disposition: / Status:
Altered topic. Please review before publication

The vehicle speed must be greater than 10 mph (16 kph) for PACCAR powered vehicles or 30 mph (49 kph) for Cummins powered vehicles for cruise control to be engaged. The cruise speed cannot exceed the maximum cruise speed (default 64 mph (103 kph)). The minimum cruise speed and maximum cruise speed are parameters which may be set by a certified dealership. This vehicle may have Cruise Control buttons located on the steering wheel instead of the switches on the dash.

1. Turn on the cruise function using Cruise Control **ON/OFF** switch. The Cruise Control indicator appears on the display.



2. Accelerate the vehicle using the accelerator pedal to the desired cruise speed.
3. Press **SET** to set the cruise speed.

i NOTE

Cruise Control may not hold the set speed going down hills. If the speed increases going down a hill, use the brakes to slow down. This will cancel Cruise Control.

The Cruise Control indicator turns green (indicating a cruise speed has been set) with the cruise speed in white appearing beside it.

4

i NOTE

Disposition: / Status:
New note. Please review before publication.

If the Cruise Control indicator is white and the cruise speed is gray, this means that a resume speed is being retained by the system and the Resume button must be pressed to re-engage the Cruise Control.

- How to Change Cruise Set Speed**
The vehicle cruise control must be on and the cruise speed engaged.
1. To increase speed:
 - Press the "+" button on the Right Steering wheel pod if available, or
 - Press the **SET** portion of the **SET/RESUME** switch on the dash
 2. To decrease speed:
 - Press the "-" button on the Right Steering wheel pod if available, or

- Press the **RESUME** portion of the **SET/RESUME** switch on the dash

Canceling and Resuming Cruise Control

Disposition: / Status:
Foot note added. Please review.

This vehicle may have Cruise Control buttons located on the steering wheel instead of the switches on the dash. There are three ways to cancel the set speed in Cruise Control:

1. Tap the brake pedal
2. Tap the clutch pedal
3. Turn the Cruise Control system OFF (using Cruise Control **ON/OFF**)¹⁵



Using the brake or clutch pedal to cancel set speed allows the operator to use the **RESUME** feature. Pressing **RESUME** will resume the vehicle speed previously set.

When turning the system off, the previous set speed is removed from memory. The operator will have to manually reset the cruise speed.

Adaptive Cruise Control (Option)

! WARNING

Disposition: / Status:
Altered Warning. Please Review

The Adaptive Cruise Control system in this vehicle is not autonomous and requires human interaction. The driver must remain alert, monitor the driving environment, and be prepared to intervene to maintain safe vehicle control. Failure to comply may result in death, personal injury, equipment damage, or property damage.

This vehicle may be equipped with Adaptive Cruise Control (ACC) to enhance standard cruise control. With a forward radar and camera to detect objects in front of the vehicle, ACC will adjust the speed of the truck to maintain a set following distance when the Cruise Control is active.

¹⁵ The first press will pause this feature and the second press will turn it OFF.

Following Distance Alerts

The display will be white when a tracked vehicle is at a proper following distance. If the following distance decreases (less than 1.5 seconds), the following distance bars will turn amber. When the following distance decrease more (0.5 seconds), the following distance bars will turn red.¹⁶

Collision Alerts Driver Screens

The digital display will show the **BRAKE** graphic and produce a fast, audible alert if the system detects a collision either from approaching speed or because of a stationary object.



Some vehicles may present the **OBJECT DETECTED** graphic to the driver, which will also produce a fast, audible alert. This is an optional icon and may vary depending on the specifications of the truck.



Both of these conditions can occur when Cruise Control and Adaptive Cruise Control are not active, providing the vehicle is moving faster than 15 mph / 24 kph.

Set ACC Following Distance

The ACC following distance can only be adjusted for those vehicles equipped with the optional, steering wheel controls. Vehicles equipped with the Menu Control Switch (MCS) use a standard, three bar, following distance.

1. Press the **Toggle** until the following distance bars illuminate in the view.

If the vehicle has Predictive Cruise Control, you may have to press the Toggle multiple times until the following distance bars are selected.

2. Deflect the **Toggle** up or down to choose the number of following distance bars.
3. Press the **Toggle** again to set the new following distance.

Lane Departure Warning (Option)

A visual and audible alert will occur when a lane marking is unintentionally crossed. The operator can mute the Lane Departure Warning (LDW) audible alarm by using the **Lane Departure/ Electric Steer Assist** switch.



Air Filter Restriction Indicator (Option)

Disposition: / Status:
Grammar corrections made per SME feedback. Please review.

An Air Filter Restriction Indicator may be installed on the air filter housing or air induction piping for access to clean, filtered air.

As the filter plugs and restriction increases, a red indicator will appear in a window on the indicator. When the indicator turns on, the air filter should be replaced. The

¹⁶ Following distance value may differ based on vehicle option codes.

indicator can be reset by pressing the button at the end of the indicator.

4

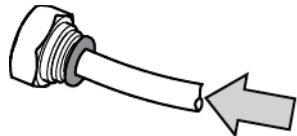
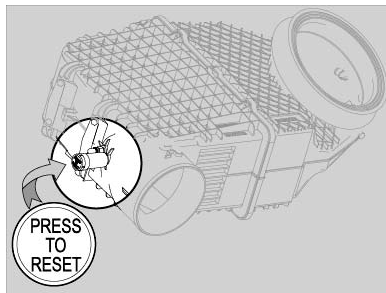

PUSH
(EMPUJAR;
POUSSER)

Transmission

Transmission Tips

Riding the Clutch

The clutch is not a footrest. DO NOT drive with your foot resting on the clutch pedal. It will allow your clutch to slip, causing excessive heat and wear, damage could result.

Release Bearing Wear

When you must idle your engine for any period of time, shift your transmission to neutral and disengage the clutch (take your foot OFF of the pedal). This helps prevent unnecessary wear to your clutch release bearing, and is less tiring for you, too.

More Tips

- Always use the clutch when making upshifts or downshifts.
- Always select a starting gear that will provide sufficient gear reduction for the load and terrain.
- Never downshift when the vehicle is moving too fast.

- Never slam or jerk the shift lever to complete gear engagement.
- Never coast with the transmission in neutral and the clutch disengaged. To provide smooth gear engagements while shifting, use proper coordination between shift lever and clutch.
- Double clutching is a very effective means to increase the service life of your transmission. Double clutching refers to a technique where the clutch pedal is used twice per shift instead of once. It also requires that you adjust the engine rpm in the middle of the shift which ultimately synchronizes the gears during shifting. Synchronizing reduces wear on the gears.

Transmission Oil Temperature Gauge



The Transmission Temperature Gauge indicates the temperature of the oil in the transmission. Watch this gauge to know when the transmission is overheating. If so,

have it checked by an authorized service representative.

Transmission Gear Display

Disposition: / Status:
 Added TX-8. Please review.

Disposition: / Status:
 "Transmission mode" changed to "Selected Transmission mode" in 1. Please review.

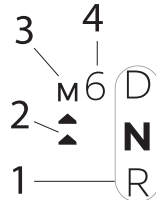

1. Selected Transmission mode (Neutral shown)
2. Gear Shift Assist (option)
3. Drive mode (Manual shown)
4. Current gear

Vehicles with the PACCAR TX-8/TX-12 transmission will show the transmission mode, current gear, and diagnostic information associated with the

transmission. This display does not apply for vehicles with Allison transmissions.

Operating Manual Transmissions

The transmission shift pattern for your vehicle may be located on the shift control knob. In addition to understanding the shift pattern and its location, you should read the transmission manufacturer's manual provided with your vehicle before operating the vehicle. After making sure the vehicle's oil and air pressure are correct and all other parts and systems are in proper working condition:

1. For vehicles with a clutch pedal, locate the clutch pedal and engage the clutch brake.
2. Shift into a low gear.

CAUTION

Always use first gear or a low speed range to start the vehicle in motion. The use of a higher gear or speed range forces undue strain on the engine, clutch, and other transmission components, and may cause damage.

3. Evaluate the road surface conditions and terrain your vehicle

is on. Select a gear low enough to let your vehicle start forward with the throttle at idle.

4. Push the parking brake valve handle (yellow) against the dash panel to release the brake.
5. Release the clutch pedal (manual only), then gradually accelerate to permit smooth starting.
6. DO NOT allow your vehicle to roll (even a little) in the opposite direction during clutch engagement. If you need to start up on an incline, apply your service brakes before you release the parking brake. Then release your service brake as you engage the clutch and apply throttle.

For further instructions on operating your transmission, see the transmission manufacturer's Driver/Operator's Instruction Manual.

If you want to shift directly into any gear other than first or reverse, depress the clutch pedal only far enough to release the clutch. Fully depressing the pedal applies the clutch brake and could cause gear hang-up.

If you have a misaligned gear condition in your vehicle's transmission and cannot start, gradually release the clutch, allowing

4

the drive gear teeth to line up properly. Then the drive gear can roll enough to allow the teeth to line up properly and complete the shift. The best engine performance and maximum economy is obtained if gears are properly selected. This efficiency is achieved by always selecting gears within optimum engine rpm, which is where maximum torque and power are obtained. Shift carefully in a new vehicle. The transmission may be a little stiff at first. Avoid gear clashing, by closely following these procedures. When you are operating a new vehicle or one that has been exposed to cold weather, you want the transmission lubricant (fluid) to circulate and coat the contacting surfaces of the gears. Metal contacting metal in moving parts may seriously damage your transmission, do not drive in one gear for long periods of time until the transmission lubricant has a chance to coat all contacting surfaces.

- Always select a starting gear that will provide sufficient gear reduction for the load and terrain.
- Never downshift when the vehicle is moving too fast.
- Never slam or jerk the shift lever to complete gear engagement.

- Never coast with the transmission in neutral and the clutch disengaged.

How to Use the Hydraulic Clutch

 **CAUTION**

Be careful not to apply the clutch brake while the vehicle is moving. The purpose of the clutch brake is to stop the transmission so that you can shift into a starting gear without grinding gears. Applying the clutch brake when the vehicle is moving causes a braking effect on the drivetrain and shortens the service life of the clutch brake.

 **CAUTION**

DO NOT push the clutch pedal completely to the floor when shifting while the vehicle is in motion. using the clutch brake while shifting a vehicle in motion will damage the clutch brake. A non functioning clutch brake will make shifting very difficult when the vehicle is stationary.

1. Depress the clutch pedal past the first 1/2 in. (13 mm) for approximately 5 1/2 in. (139.7 mm) of total pedal travel.
2. Depress the clutch pedal another 1/2 in. (13 mm) to engage the clutch brake.

The clutch brake is used for stopping transmission gears, allowing you to easily shift into first gear or reverse without grinding gears. The clutch brake is not necessary when shifting into other gears while in motion.

If the clutch pedal is pressed completely to the floor and the transmission is not shifting, then it is time to have the clutch adjusted or serviced.

If the transmission has a butt-tooth condition and you cannot engage a gear, gradually release the clutch. Then the drive gear can roll enough to allow the teeth to line up properly and complete the shift. The clutch is not a footrest. Do not drive with your foot resting on the clutch pedal. It will allow your clutch to slip, causing excessive heat and wear, damage could result.

When you must idle your engine for any period of time, shift your transmission to neutral and disengage the clutch (take your foot OFF of the pedal). This helps prevent

unnecessary wear to your clutch release bearing, and it is less tiring for you, too.

- Always use the clutch when making upshifts or downshifts.
- Never coast with the transmission in neutral and the clutch disengaged.
- To provide smooth gear engagements while shifting, use proper coordination between shift lever and clutch.

How to Shift Using Double Clutch Method

Double clutching is easier on the transmission and on the engine, helping match your vehicle's engine speed with driveline speed to achieve clash-free shifts. The manual transmission in your vehicle is not equipped with gear synchronizers. Whether you are upshifting or downshifting, it is best to double clutch. To double clutch:

1. Push the clutch pedal down to disengage the clutch.
2. Move the gear shift lever to neutral.
3. Release the pedal to engage the clutch. This lets you control the rpm of the transmission mainshaft gears, allowing you to match the

rpm of the mainshaft gears to those of the output shaft.

- Upshifts: let the engine and gears slow down to the rpm required for the next gear.
 - Downshifts: press accelerator, increase engine and gear speed to the rpm required in the lower gear.
4. Now quickly press the pedal to disengage the clutch and move the gear shift lever to the next gear speed position.
 5. Release the pedal to engage the clutch.

Automatic Transmissions

An automatic transmission makes shifting much easier. It remains important to completely understand how to operate the transmission to optimize its efficiency. Please read the manual for your automatic transmission included with your vehicle.

 WARNING
Disposition: / Status:

Change of terminology (truck by vehicle) per SME request. Please review.
DO NOT leave the cab of your vehicle without applying the parking brake. The vehicle could roll and cause an accident resulting in death or personal injury. Always apply the parking brake before you leave the cab.

Automated Transmissions

Disposition: / Status: Altered topic. Please review before publication.

Please read the transmission operator manual included with your vehicle to completely understand how to operate the transmission to optimize its efficiency. Not all automated transmissions have a "park" position, so you will need to apply the parking brake before leaving the cab.

4

 **WARNING**

If your vehicle has an automated transmission, the vehicle can roll backwards when stopped or started on a hill or grade. To prevent rolling, observe the following guidelines:

- When stopped on a hill or grade, press the brake pedal.
- When starting from a stop on a hill or grade, quickly remove your foot from the brake pedal and firmly press on the accelerator pedal.

Failure to comply may result in death, personal injury, equipment damage, or property damage.

 **WARNING**

Disposition: / Status:
Change of terminology (truck by vehicle) per SME request. Please review.

DO NOT leave the cab of your vehicle without applying the parking brake. The vehicle could roll and cause an accident resulting in death or personal

injury. Always apply the parking brake before you leave the cab.

Shift Configuration

Some transmissions are equipped with more than one shifting configuration to match various operating conditions. Please read the automated transmission manual included with your vehicle for instructions on how to change shift configurations.

Auxiliary Transmission

If you have an auxiliary transmission, see your transmission manufacturer's manual for its proper operation.

Steerable Drive Axle

Disposition: / Status:
Information modified. Please review.

 **NOTE**

The customer cannot change axle ratios or tires without first obtaining approval from PACCAR. Contact your nearest dealer.

If you have a Steerable Drive Axle installed on your vehicle, refer to the Axle Operator's Manual to learn how operate correctly.

Air Brake System (option)

This vehicle's braking system and many vehicle accessories may depend on the storage and application of a high-pressure air supply. For vehicles equipped with an air brake system, the service brake, parking brake, and trailer brake will utilize this supply. Vehicles equipped with an air brake system are of the dual circuit type: it has a circuit for the front wheels, a separate circuit for the rear wheels, and one for the trailer. The system is supplied by an engine-driven compressor. The vehicle's compressor takes outside air and compresses it, usually to 100-130 psi (689-896 kPa). The compressor air then goes to the air tanks to be stored until needed. When you operate your air brakes, the stored compressed air flows into the chambers where it is used to apply your vehicle and trailer brakes. That is why, when you push down on the brake pedal, you do not feel the same amount of

pressure on the pedal that you do when you apply the brakes on your car. All you are doing on your truck is opening an air valve to allow air to flow into the brake chambers.



WARNING

Disposition: / Status:
 Altered Warning. Please review before publication.

The anti-lock brake system is a critical vehicle safety system. For the safety of you and others around you, have the vehicle submitted for periodic preventive maintenance checks as well as having any suspected problems immediately checked by an authorized dealer. Failure to properly maintain your brake system can lead to serious accidents. Failure to comply may result in death, personal injury, equipment damage, or property damage.



WARNING

Never drive your vehicle with the parking brake applied. Always release the parking brake prior to moving the vehi-

cle. Failure to disengage the parking brake prior to moving your vehicle could result in excessive heat buildup in the brake system, resulting in premature failure of the braking system and/or a fire. Failure to comply may result in death, personal injury, equipment damage, or property damage.



NOTE

Today's diesel engines have significant torque and startability power at low rpm. Combinations of engine speed and available torque may over-power the vehicle's parking brake.

Front Brake System

Disposition: / Status:
 Change of terminology (truck by vehicle) per SME request. Please review.

When the brake pedal is depressed, the front circuit portion of the treadle valve delivers air from the front service air tank to the front axle brake chambers via a quick-release valve. Simultaneously (on full vehicle configurations), air is also supplied to the

modulating valve control port. In the event of a rear service circuit failure, the modulating valve will exhaust air from the spring brake chambers, applying the spring brakes in proportion to the front circuit application.

Rear Brake System

When the brake pedal is depressed, the rear circuit portion of the treadle valve delivers air from the rear service air tank to the service brake relay valve control port. The relay valve then delivers air directly from the rear service air tank to the rear brake chambers in proportion to the treadle pressure.

Using the Parking Brake

The yellow diamond-shaped knob on the dash controls the vehicle parking brake. These are spring brakes that you activate by releasing air pressure from their chambers. When they are not in use, air pressure compresses the springs and releases the brakes. Pulling the valve OUT applies the parking brake, which exhausts air from the chambers and allows the springs to extend and apply the brakes.

4

WARNING

Disposition: / Status:
Change of terminology (truck by vehicle) per SME request. Please review.

DO NOT leave the cab of your vehicle without applying the parking brake. The vehicle could roll and cause an accident resulting in death or personal injury. Always apply the parking brake before you leave the cab.

Combination (Vehicle/Trailer) Parking Brake Control Valves

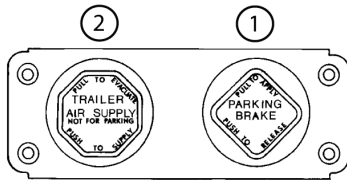

1. Parking Brake Control (Yellow)
2. Trailer Air Supply Control (Red)

Before You Leave the Cab

1. Apply all parking brakes. Pull out the **Yellow** Parking Brake Control

knob (1) located on the dash. The **Red** (octagon-shaped) Trailer Air Supply Control knob will automatically pop out. (A dash warning light will indicate when the brake is ON.)

2. **Disposition: / Status:**
Fixed misspelling error in the bullet list. Please review.

Shift the transmission into PARK position:

- Manual transmission, select First or Reverse gear.
 - Automatic transmission, select Neutral.
3. Turn the key to OFF.
 4. Remove the key.

WARNING

Do not pull out the parking brake valve while the vehicle is moving. Stopping with the parking brake controls can cause a sudden wheel lockup, loss of control, or over-take by following vehicles. Failure to comply may result in property damage personal injury, or death.

The parking brake acts on the rear wheels only. They are spring-applied, with air pressure used to release them. Release air is supplied by both the front and rear circuit air tanks through a double check valve.

To Release the Vehicle Parking Brake ONLY

- Push IN the **Yellow** knob on the dash. Your trailer will remain parked.
- Below 60 psi (414 kPa) the **Yellow** parking brake valve remains OUT (ON position). If air pressure is not restored above 60 psi (414 kPa), the knob will automatically return to the OUT position if you attempt to push it in. Check the Primary and Secondary Air Pressures in the Primary Gauges gauge view.

To Release the Trailer Brake ONLY

- Push IN the **Red** knob on the dash. The vehicle will remain parked.

To Release the Full Combination of Brakes

- Push IN **BOTH** knobs on the dash.
- In the event that air pressure is reduced below a safe level: the low

air warning light will come on first; if air pressure continues to drop, the parking brake valve will pop OUT, automatically applying the spring brakes.



WARNING

If the air pressure falls below 60 psi (414 kPa), the spring brakes may abruptly stop the vehicle. Monitor air-pressure gauges. If the air-pressure alert is activated, DO NOT DRIVE the vehicle until it is serviced. Failure to comply may result in death or personal injury.



WARNING

DO NOT use the service brake or trailer hand brake to hold a parked vehicle. Because these brakes rely on air pressure, a loss of pressure could loosen the brakes and cause the vehicle to roll, resulting in an accident. Always set the parking brake. Failure to comply may result in property damage, personal injury, or death.



CAUTION

DO NOT attempt to move the vehicle before air system pressure reaches 100 psi (689 kPa). The wheels may still be locked by the spring brakes, resulting in unnecessary brake wear or damage. Failure to comply may result in equipment damage or property damage.

Vehicle/Trailer Air Supply Valve

Initial Charge

The red octagon knob controls the air supply to the trailer. With the system completely discharged, both the **Red** (trailer air supply) and the **Yellow** (parking brake) knobs are OUT; thus, vehicle and the trailer parking (spring) brakes are applied.

To supply air to the trailer system and release the trailer parking brake:

1. Allow the vehicle air system pressure to build up to operating level.

2. When system pressure reaches 50 psi (345 kPa) the **Red** knob may be pushed IN.
3. Hold the **Red** knob IN by hand until the trailer air pressure builds to a pre-set level, about 45 psi (310 kPa). At this point it will remain in, charging the trailer system and releasing only the trailer brakes.
4. The **Yellow** knob will remain OUT (vehicle brakes ON).

4

Normal Run Position

- The **Yellow** knob (system park) may now be pushed IN, which will supply air to the vehicle spring brakes, releasing them.

4

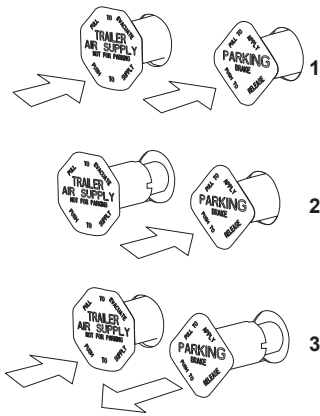

1. Normal Run Position
2. Trailer Park with Vehicle Released
3. System Park or Trailer Charge with Vehicle Parked

Trailer Park or Emergency Brake Application Only

If you ever have a failure or disconnect the air supply hose to the trailer, the trailer parking brake will set. The **Red knob** will automatically pop OUT and seal off the vehicle air tanks to protect the vehicle air system pressure.

To apply the trailer brakes only: Pull OUT the **Red knob**. This will exhaust air from the trailer supply line, causing the vehicle protection valve to close and the trailer spring brakes to apply. The trailer is now in emergency or park. This mode would be used to uncouple from the trailer (running without a trailer connected).

 <p>WARNING</p>
<p>DO NOT use the service brake or trailer hand brake to hold a parked vehicle. Because these brakes rely on air pressure, a loss of pressure could loosen the brakes and cause the vehicle to roll, resulting in an accident. Always set the parking brake. Failure to comply may result in property damage, personal injury, or death.</p>

System Park

With both knobs pushed in for normal operating modes, the parking brakes of both the vehicle and the trailer may be applied by pulling the **Yellow knob** OUT. This will exhaust the air from the vehicle spring brakes, and simultaneously cause the **Red knob** to pop OUT, which will apply the trailer brakes. This complies with the

Federal Motor Vehicle Safety Standards (FMVSS) 121 requirement that one control should apply all the parking brakes on the vehicle.

Trailer Charge

To recharge the trailer when both knobs are OUT (combination vehicle is parked), push in the **Red knob**. This will repressurize the trailer supply line. The vehicle will remain parked. For more information on air supply pressure requirements, see *Initial Charge* on page 147.

Trailer Brake Hand Valve

This hand valve provides air pressure to apply the trailer brakes only. It operates independently of the foot treadle valve. To operate the trailer brake hand valve:

- Pull down on the lever under the right side of the steering wheel.
- The valve is self-returning. When pressure is removed from the valve lever, it will return to the OFF position.



CAUTION

Disposition: / Status:
 Altered Caution. Please review before publication.

The trailer brake is not to be used as a substitute for the service brakes. Using this brake frequently, instead of using the foot brake, will cause the trailer brakes to wear out sooner. Failure to comply may result in equipment or property damage.



WARNING

DO NOT use the service brake or trailer hand brake to hold a parked vehicle. Because these brakes rely on air pressure, a loss of pressure could loosen the brakes and cause the vehicle to roll, resulting in an accident. Always set the parking brake. Failure to comply may result in property damage, personal injury, or death.

Brake Components

The following is a brief description of the air/brake system.

- Compressor** Supplies air to the system. System pressure is controlled by the governor.
- Governor** Controls the air pressure in the system by actuating the compressor discharge mechanism. Its cut-out pressure is 115 to 125 psi (793 to 862 kPa). Its preset cut-in pressure is set to between 13 to 25 psi (90 to 172 kPa) below the cut-out pressure setting (cut-out and cut-in interval is not adjustable).
- Safety Valve** Installed on the supply air tank outlet. It should vent off at 150 psi (1034 kPa) permitting air to escape.
- Air Dryer** Collects and removes moisture and contaminants from the air as it travels from the compressor to the wet tank.
- Compressed Air Tanks** The wet tank receives air from the air dryer and cools it somewhat, allowing moisture to condense for draining. Relatively dry air is then supplied to the two service air tanks for distribution to their respective brake circuits. The service air tanks are isolated from each other by check valves.
- Dual Service Brake Treadle Valve** Delivers air to the two service brake circuits.
- Double Check Valve** Directs the higher air pressure from either the rear (primary) or front (secondary) service air tank to the modulating valve.
 - * Limits spring brake hold-off air pressure delivered to the spring brake chambers.
 - * Provides a quick release of air pressure from the spring brake chambers to speed spring brake application.
 - * Modulates spring brake application in proportion to front service application in the event of a rear service failure.
 - * Prevents compounding of service and spring applications..
- Modulating Valve (SR-1)** Used only on full trucks, not tractors, performs four functions:
- Quick-Release Valve** Speeds the release of air from the brake chambers. When air is released, the air in the brake chambers is exhausted at the quick-release valve, rather than exhausting back through the treadle valve.
- Single Check Valve** Allows air flow in one direction only.
- Parking Brake Valve** Yellow diamond-shaped knob. It controls the application and release of the parking (spring) brakes of the vehicle or of the vehicle-trailer combinations. If the air system is being charged from zero pressure, the parking brake valve will not hold in the release position until the system pressure exceeds 60 psi (414

4

Trailer Supply Valve

kPa), which is the pressure required to override the load of this valve's plunger return spring.

The Red octagonal-shaped knob protects the vehicle system; it functions in conjunction with the parking brake valve (yellow). The trailer supply valve is responsible for synchronizing the vehicle and trailer parking and emergency brakes. If the air system is being charged from zero pressure, the trailer supply valve will not hold in the applied position until the system pressure exceeds 50 psi (345 kPa). It automatically pops out and exhausts air if supply air pressure drops below 60 psi (414 kPa).

Vehicle Protection Valve

The functions of this valve are to (1) receive all pneumatic signals pertinent to the operation of the trailer brake system, (2) transmit these signals to the trailer, and (3) protect the vehicle air supply in case of separation of the air lines connecting the vehicle to the trailer.

Brake Safety and Emergency

 **WARNING**

Do not operate the vehicle in the event of a malfunction in any air circuit. The vehicle should not be operated until the system is repaired and both braking circuits, including all pneumatic and mechanical components, are working properly. Loss of system air can cause the service brakes to not function resulting in the sudden application of the spring brakes causing wheel lock-up, loss of control, or overtake by following vehicles. Failure to comply may result in property damage, personal injury, or death.

- If pressure is lost in the vehicle front or rear circuit, the "check" valves isolate the unaffected circuit, allowing this circuit to continue normal operation. The trailer brakes are still functional.
- If air pressure is lost in the trailer supply/park circuit, and the

pressure drops below 60 psi (414 kPa), the trailer spring brakes are automatically applied, and the vehicle air pressure circuits are unaffected.

- If air pressure is lost in the trailer brake service circuit, and the pressure in the vehicle front and rear circuits drops below 60 psi (414 kPa), the vehicle and trailer spring brakes are automatically applied.

ABS Warning Lamp

The ABS warning lamp will come on briefly, then go off, when the key switch is first turned on. If the lamp remains ON until a speed of 4 mph (6 km/h) is reached, then goes OFF, there may be a stored fault code. If the lamp remains ON when a speed in excess of 4 mph (6 km/h) is reached, there may be an active fault in the ABS system.