

DFS TEST REPORT

Product Name : Android Tv Box
Trade mark : Eon Samrt Box
Model No. : SDOTT0202
FCC ID : 2AUWA-ATV4K85198
Report Number : BLA-EMC-202107-A7506
Date of sample receipt : 2021/7/19
Date of Test : 2021/7/19 to 2021/8/18
Date of Issue : 2021/8/18
Test standard : FCC CFR Title 47 Part 15 Subpart
E Section 15.407
Test result : PASS

Prepared for:

Shenzhen SDMC Technology Co.,Ltd.
7/F, W2-A, Hi-Tech, Industrial Park, Nanshan District

Prepared by:

BlueAsia of Technical Services(Shenzhen) Co., Ltd.
Building C, No. 107, Shihuan Road, Shiyuan Sub-District, Baoan District,
Shenzhen, Guangdong Province, China
TEL: +86-755-23059481

Compiled by: *Sven*

Review by: *Sueels*

Approved by: *Blue Zheng*

Date: 2021/8/18



BlueAsia of Technical Services(Shenzhen) Co., Ltd.

Add: Building C, No. 107, Shihuan Road, Shiyuan Sub-District, Baoan District, Shenzhen,
Guangdong Province, China

Tel: +86-755-23059481 Email: marketing@cblueasia.com www.cblueasia.com



2 Version

Version No.	Date	Description
00	2021/8/18	Original

BlueAsia

3 Contents

	Page
.....	1
2 VERSION	2
3 CONTENTS	3
4 TEST SUMMARY	4
5 GENERAL INFORMATION	5
5.1 CLIENT INFORMATION	5
5.2 GENERAL DESCRIPTION OF E.U.T	5
5.3 DESCRIPTION OF SUPPORT UNITS	5
5.4 LABORATORY FACILITY	6
5.5 LABORATORY LOCATION	6
5.6 TEST INSTRUMENTS LIST	6
5.7 TEST ENVIRONMENT	7
6 DFS TECHNICAL REQUIREMENTS	8
6.1 DFS PARAMETERS	8
6.2 DFS TECHNICAL REQUIREMENTS	10
6.3 DFS THRESHOLD LEVEL	10
6.4 TEST SETUP BLOCK	10
6.5 EUT CONFIGURATION FOR DFS TEST	11
7 TEST RESULT	12
7.1 NON-OCCUPANCY PERIOD	12
7.2 CHANNEL MOVE TIME AND CHANNEL CLOSING TRANSMISSION TIME	13
8 EUT CONSTRUCTIONAL DETAILS	14

4 Test Summary

Test Items	Limit	Result
Channel Availability Check	> 60 seconds	N/A
UNII DetectionBandwidth	> 100% of the UNII 99% transmission power bandwidth	N/A
Statistical Performance Check	Radar type 1,2,3,4 \geq 60% Aggregate Radar type 1~4 and 5 \geq 80% Radar type 6 \geq 70%	N/A
Channel Move Time	< 10 seconds	Pass
Channel Closing Transmission Time	< 20ms + aggregate of 60ms over remaining 10 second period	Pass
Non-Occupancy Period	> 30 minutes	Pass
Note: "Pass" means meet the requirements, "N/A" means not applicable		

5 General Information

5.1 Client Information

Applicant:	Shenzhen SDMC Technology Co.,Ltd.
Address:	7/F,W2-A,Hi-Tech,Industrial Park,Nanshan District
Manufacturer	Shenzhen SDMC Technology Co.,Ltd.
Address:	7/F,W2-A,Hi-Tech,Industrial Park,Nanshan District

5.2 General Description of E.U.T.

Product Name:	Android Tv Box
Model No.:	SDOTT0202
Transmitter frequency range:	5150MHz~5250MHz, 5250MHz~5350MHz 5470MHz~5725MHz, 5725MHz~5825MHz
Modulation type:	OFDM
WLAN Function:	802.11a/802.11n/802.11ac
Bandwidth:	20MHz/40MHz/80MHz
Antenna Type:	Internal Antenna
Antenna Gain:	ANT1 3.14dBi, ANT2 3.69dBi(Provided by the applicant)
DFS Operation Type:	<input type="checkbox"/> Master Device <input type="checkbox"/> Slaver Device with Radar detection function <input checked="" type="checkbox"/> Slaver Device without Radar detection function
Power supply:	DC12V

5.3 Description of Support Units

Manufacturer	Description	Model	Serial Number
LENOVO	Laptop	SL510	2847A65
ASUS	WiFi Router	GT-AXE11000	M3IAJF201052

Information about the WiFi router is as follows :

Supported frequencies:

5150MHz~5250MHz, 5250MHz~5350MHz

5470MHz~5725MHz, 5725MHz~5825MHz

FCC ID:MSQ-RTAXJF00



5.4 Laboratory Facility

The test facility is recognized, certified, or accredited by the following organizations:

- FCC — Designation No.: CN1252
 BlueAsia of Technical Services(Shenzhen) Co., Ltd has been registered and fully described in a report filed with the (FCC) Federal Communications Commission. The acceptance letter from the FCC is maintained in files. Designation CN1252.
- ISED — CAB identifier No.: CN0028
 BlueAsia of Technical Services(Shenzhen) Co., Ltd has been registered by Certification and Engineering Bureau of ISED for radio equipment testing with CAB identifier CN0028

5.5 Laboratory Location

All tests were performed at:
 BlueAsia of Technical Services(Shenzhen) Co., Ltd.
 Building C, No. 107, Shihuan Road, Shiyuan Sub-District, Baoan District, Shenzhen, Guangdong Province, China
 Telephone: TEL: +86-755-28682673 FAX: +86-755-28682673
 No tests were sub-contracted.

5.6 Test Instruments list

Conducted method:					
Test Equipment	Manufacturer	Model No.	Serial No.	Cal.Date	Cal.Due
Spectrum Analyzer	Agilent	N9020A	MY49100060	2020/10/12	2021/10/11
Universal Radio	Rohde & Schwarz	CMW500	1201-002K50	2020/10/12	2021/10/11

Communication Tester					
Vector Signal Generator	Agilent	E4438C	MY45092582	2020/10/12	2021/10/11
Signal Generator	Agilent	E8257D	MY44320250	2020/10/12	2021/10/11
Power Sensor	D.A.R.E	RPR3006W	17I00015SNO27	2020/10/12	2021/10/11
Power Sensor	D.A.R.E	RPR3006W	17I00015SNO28	2020/10/12	2021/10/11
DC Power Supply	LODESTAR	LP305DE	N/A	2020/10/12	2021/10/11
Temperature Humidity Chamber	Mingle	TH101B	N/A	2020/10/12	2021/10/11
DFS Test Software	Tonscend	N/A	N/A	N/A	N/A

5.7 Test Environment

Temperature:	20 ~ 25 °C
Humidity:	60% ~ 65%
Atmospheric pressure:	1010 kPa

6 DFS Technical Requirements

6.1 DFS Parameters

Table D.1: Applicability of DFS Requirements Prior to Use of a Channel			
Requirement	Operational Mode		
	Master	Client Without Radar Detection	Client With Radar Detection
Non-Occupancy period	Yes	Not required	Yes
DFS Detection Threshold	Yes	Not required	Yes
Channel Availability Check Time	Yes	Not required	Not required
U-NII Detection Bandwidth	Yes	Not required	Yes

Table D.2: Applicability of DFS requirements during normal operation		
Requirement	Operational Mode	
	Master	Client Without Radar Detection
DFS Detection Threshold	Yes	Not required
Channel Closing Transmission Time	Yes	Yes
Channel Move Time	Yes	Yes
U-NII Detection Bandwidth	Yes	Not required

Additional requirements for devices with multiple bandwidth modes	Operational Mode	
	Master Device or Client with Radar Detection	Client Without Radar Detection
U-NII Detection Bandwidth and Statistical Performance Check	All BW modes must be tested	Not required
Channel Move Time and Channel Closing Transmission Time	Test using widest BW mode available	Test using the widest BW mode available for the link
All other tests	Any single BW mode	Not required

Note: Frequencies selected for statistical performance check (Section 7.8.4) should include several frequencies within the radar detection bandwidth and frequencies near the edge of the radar detection bandwidth. For 802.11 devices it is suggested to select frequencies in each of the bonded 20 MHz channels and the channel center frequency.

Table D.3: DFS Detection Thresholds	
Maximum Transmit Power	Value (See Notes 1,2, and 3)
EIRP \geq 200 mW	-64 dBm
EIRP < 200 mW and power spectral density < 10 dBm/MHz	-62 dBm
EIRP < 200 mW that do not meet the power spectral density requirement	-64 dBm

Note 1: This is the level at the input of the receiver assuming a 0 dBi receive antenna.
 Note 2: Throughout these test procedures an additional 1 dB has been added to the amplitude of the test transmission waveforms to account for variations in measurement equipment. This will ensure that the test signal is at or above the detection threshold level to trigger a DFS response.
 Note3: EIRP is based on the highest antenna gain. For MIMO devices refer to KDB Publication 662911 D01.

Table D.4: DFS requirement values	
Parameter	Value
Non-occupancy period	Minimum 30 minutes
Channel Availability Check Time	60 seconds
Channel Move Time	10 seconds (See Note 1)
Channel Closing Transmission Time	200 ms + an aggregate of 60ms over remaining 10 second period (See Notes 1 and 2)
U-NII Detection Bandwidth	Minimum 100% of the UNII 99% transmission power bandwidth (See Note 3)

Note 1: Channel Move Time and the Channel Closing Transmission Time should be performed with Radar Type 0. The measurement timing begins at the end of the Radar Type 0 burst.

Note 2: The Channel Closing Transmission Time is comprised of 200 milliseconds starting at the beginning of the Channel Move Time plus any additional intermittent control signals required to facilitate a Channel move (an aggregate of 60 milliseconds) during the remainder of the 10 second period. The aggregate duration of control signals will not count quiet periods in between transmissions.

Note 3: During the U-NII Detection Bandwidth detection test, radar type 0 should be used. For each frequency step, the minimum percentage of detection is 90 percent. Measurements are performed with no data traffic.

Table D.5: Short Pulse Radar Test Waveforms					
Radar Type	Pulse Width (μsec)	PRI (μsec)	Number of Pulses	Minimum Percentage of Successful Detection	Minimum Number of Trials
0	1	1428	18	See Note 1	See Note 1
1	1	Test A Test B	Roundup $\left\{ \begin{array}{l} \frac{1}{360} \\ \frac{19 \cdot 10^6}{PRI_{\mu sec}} \end{array} \right\}$	60%	30
2	1-5	150-230	23-29	60%	30
3	6-10	200-500	16-18	60%	30
4	11-20	200-500	12-16	60%	30
Aggregate (Radar Types 1-4)				80%	120

Note 1: Short Pulse Radar Type 0 should be used for the detection bandwidth test, channel move time, and channel closing time tests.

Table D.6: Long Pulse Radar Test Waveform							
Radar Type	Pulse Width (μsec)	Chirp Width (MHz)	PRI (μsec)	Number of Pulses per Burst	Number of Bursts	Minimum Percentage of Successful Detection	Minimum Number of Trials
5	50-100	5-20	1000-2000	1-3	8-20	80%	30

Long Pulse Radar Test Signal Wave form 12 second transmission

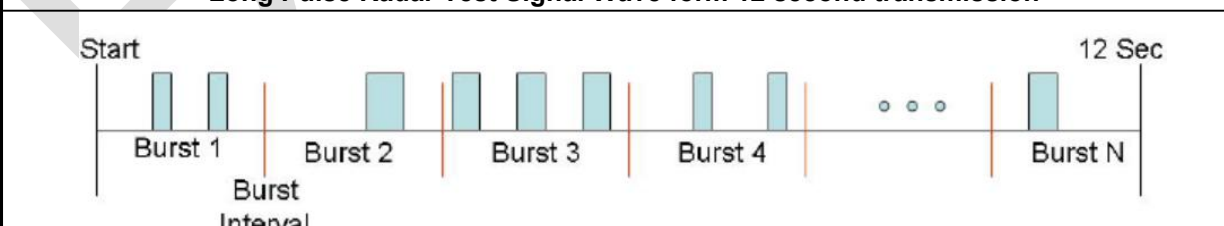

Table D.7: Frequency Hopping Radar Test Waveform							
Radar Type	Pulse Width (μsec)	PRI (μsec)	Pulses per Hop	Hopping Rate (kHz)	Hopping Sequence Length (msec)	Minimum Percentage of Successful Detection	Minimum Number of Trials
6	1	333	0	0.333	300	70%	30

6.2 DFS Technical Requirements

Requirement	DFS Operational mode		
	<input type="checkbox"/> Master	<input checked="" type="checkbox"/> Slave without Radar Detection	<input type="checkbox"/> Slave with Radar Detection
Channel Availability Check	√	Not Required	Not Required
UNII Detection Bandwidth	√	Not Required	√
Statistical Performance Check	√	Not Required	√
Channel Move Time	√	√	√
Channel Closing Transmission Time	√	√	√
Non-Occupancy Period	√	√	√

6.3 DFS Threshold Level

DFS Threshold Level	
5250MHz ~ 5350MHz	-62dBm @ antenna connector
5470MHz~5725MHz	-62dBm @ antenna connector

Note: The worst case level was selected to perform the test.

6.4 Test Setup Block

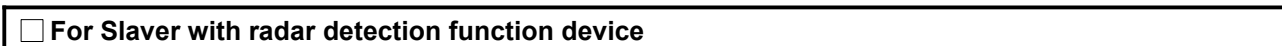
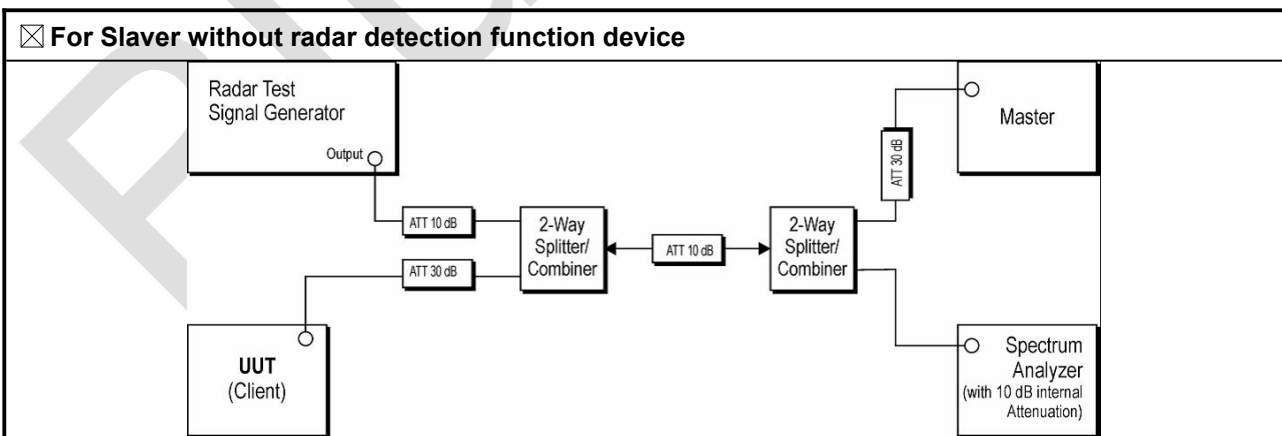
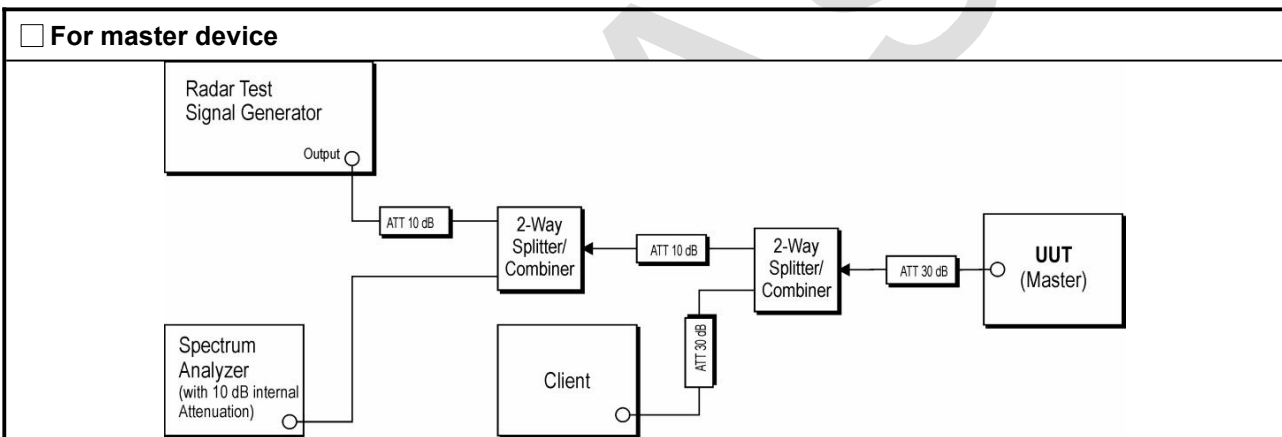

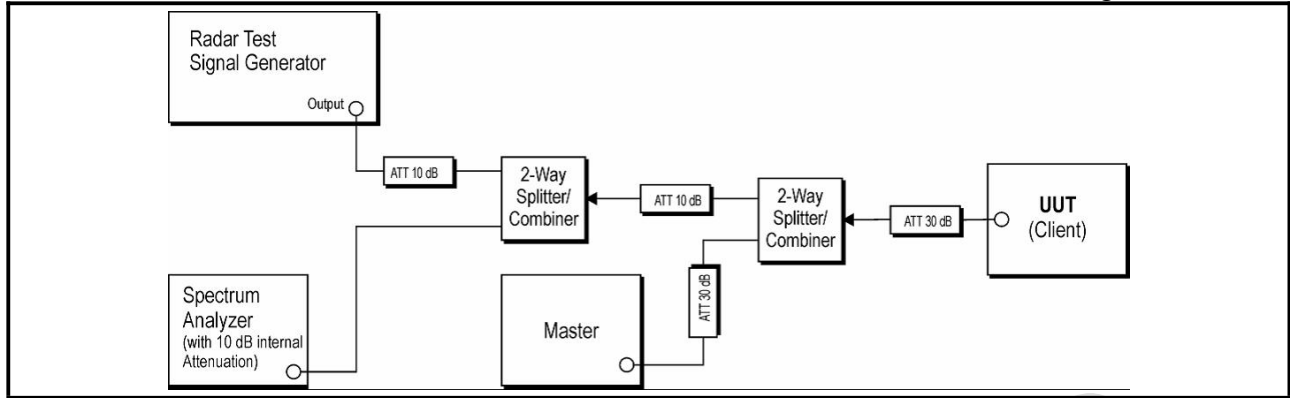

6.5 EUT Configuration for DFS Test

Test Items	Channel Frequency
Channel Move Time	5300MHz, 5600MHz
Channel Closing Transmission Time	5300MHz, 5600MHz
Non-Occupancy Period	5300MHz, 5600MHz

7 Test Result

7.1 Non-Occupancy Period

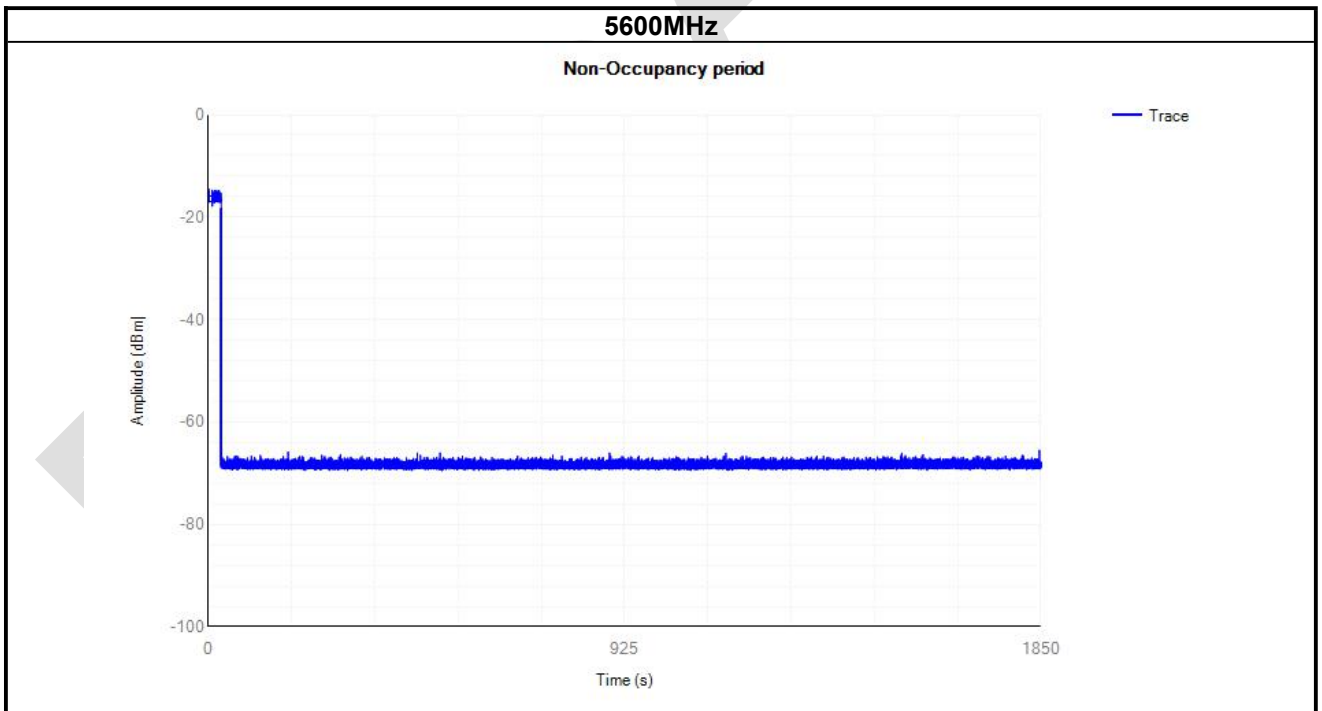
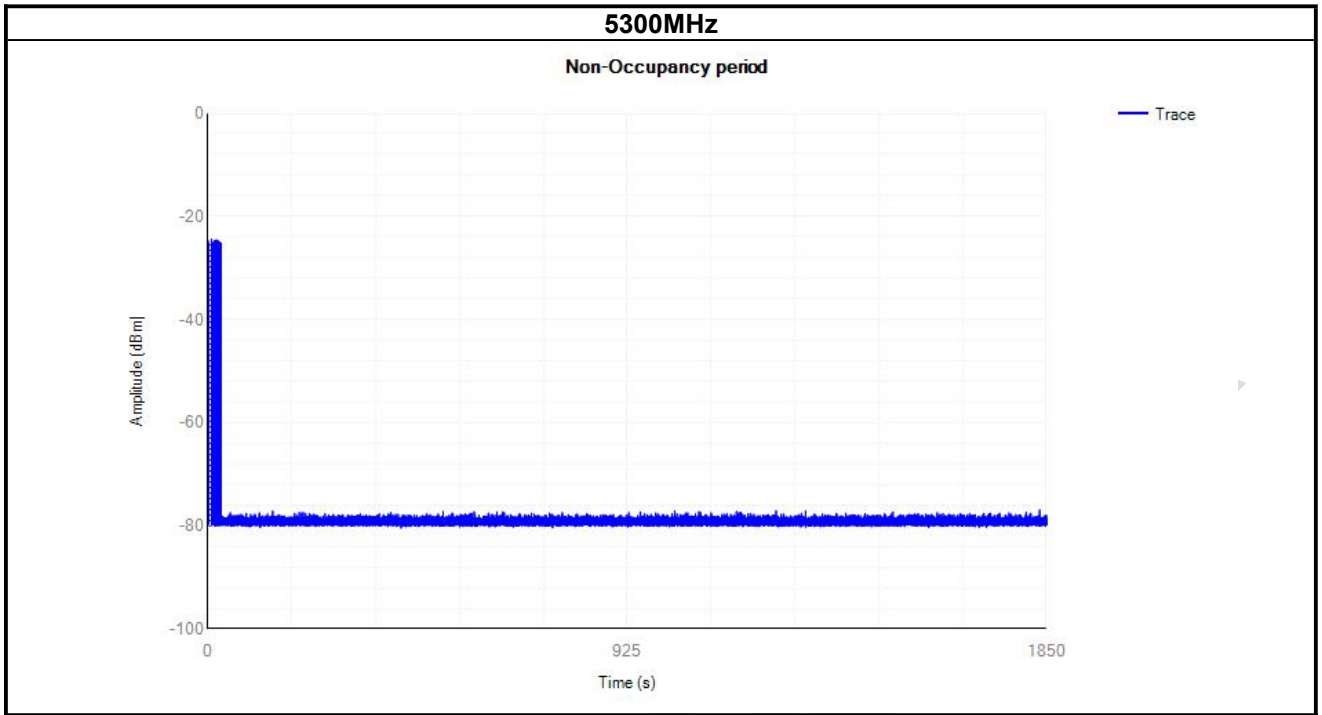

Test Items	Value	Limit	Result
Non-Occupancy Period	> 30 minutes	Minimum 30 minutes	Pass

7.2 Channel Move Time and Channel Closing Transmission Time

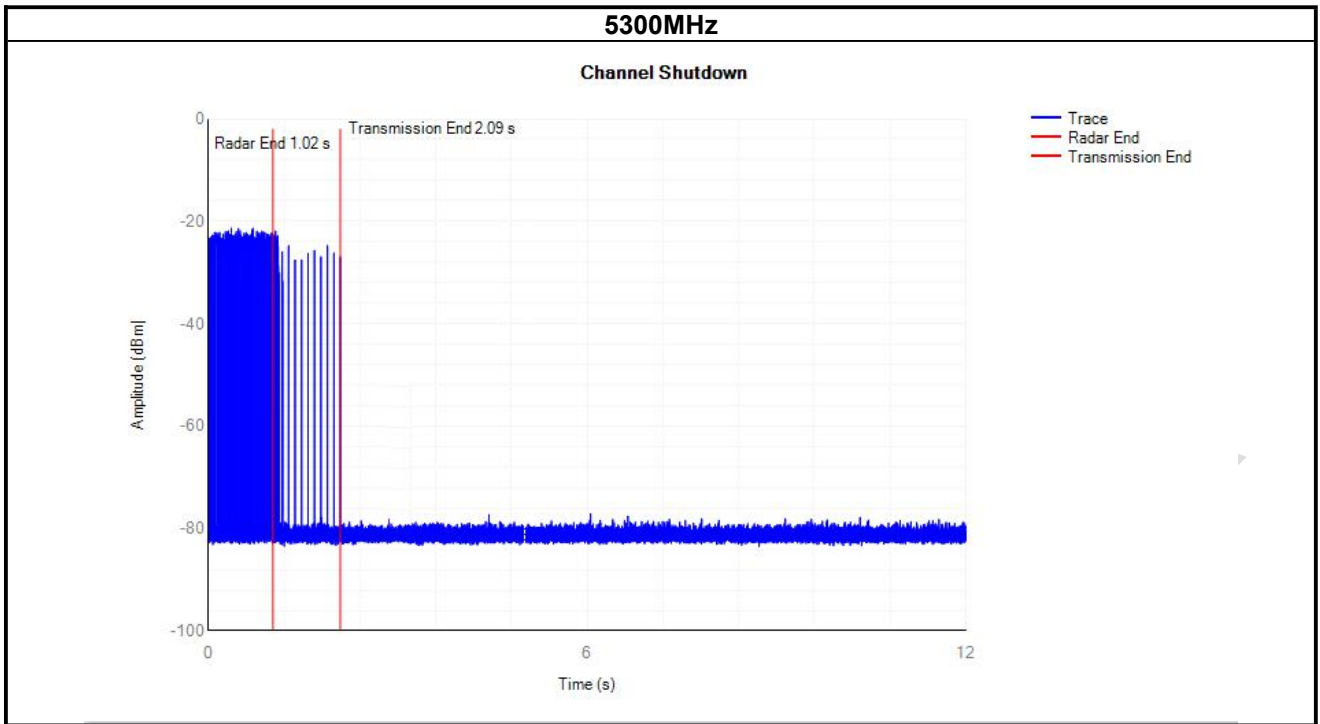

Test Items	Value	Limit	Result
Channel Closing Transmission Time	0.036s	1s	Pass
Channel Move Time	1.0678s	10 s	Pass

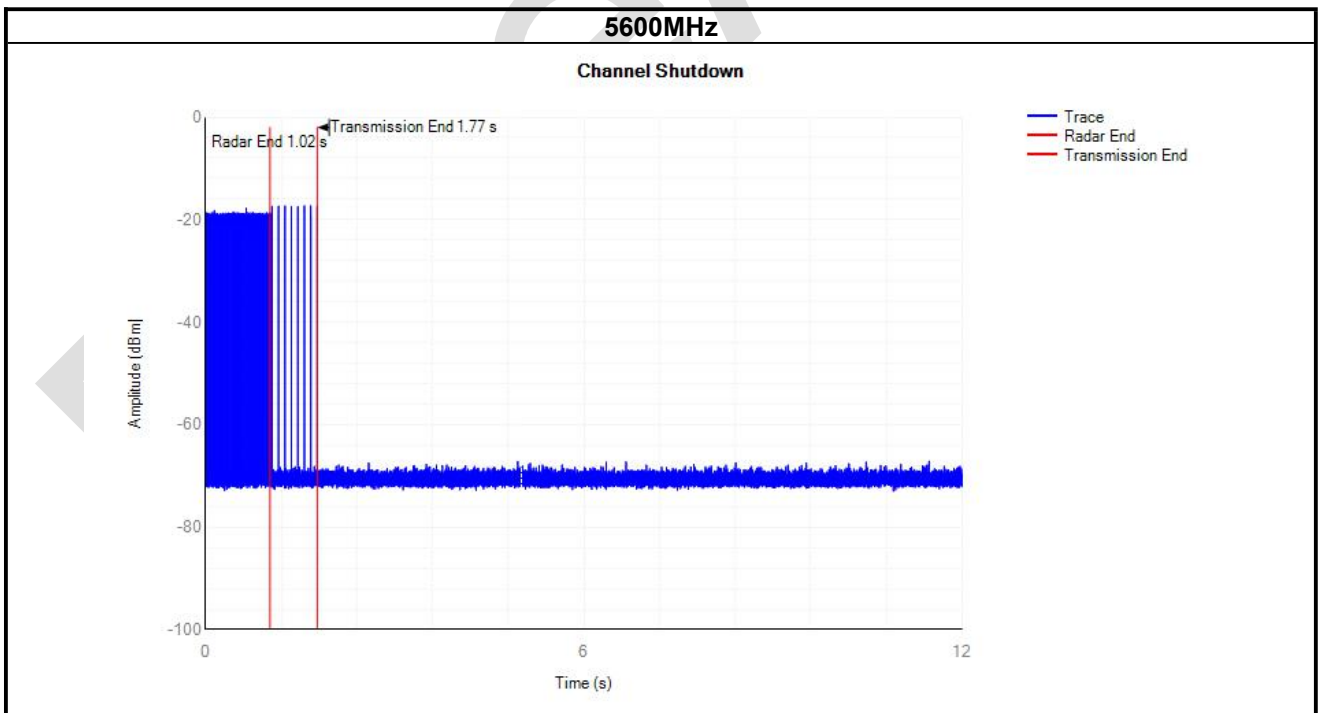

Test Items	Value	Limit	Result
Channel Closing Transmission Time	0.0112s	1s	Pass
Channel Move Time	0.7494s	10s	Pass

8 EUT Constructional Details

Reference to the test report No. BLA-EMC-202107-A7501

----- End of report -----

BlueAsia