



CIR215A Contactless Smart Card Reader

User Manual

Driver installation Procedure

** Driver signed by Microsoft and WHQL, user can install the driver with Window Update. In case that cannot install via Window Update, please process the below steps to Manual installation*

Hardware requires:

- ❖ CIR215A
- ❖ PC with OS windows 7 or above

Software requires:

- ❖ CIR215 Driver Package

Steps:

1. Connect CIR215A to PC
2. On PC, open “Control Panel > System”

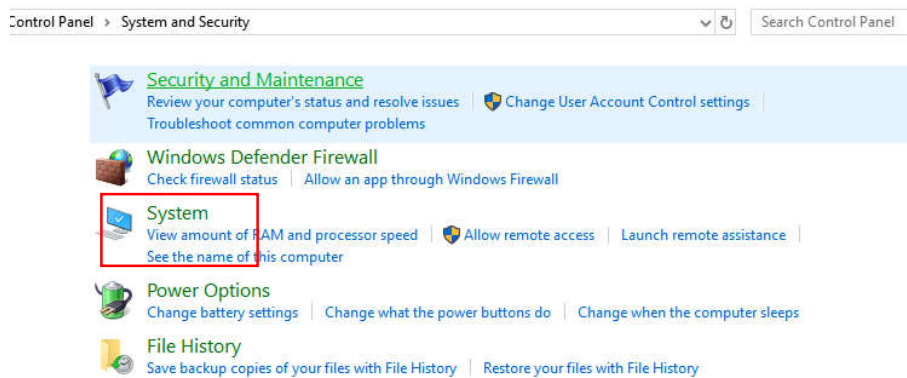

3. Open “Device Manager”

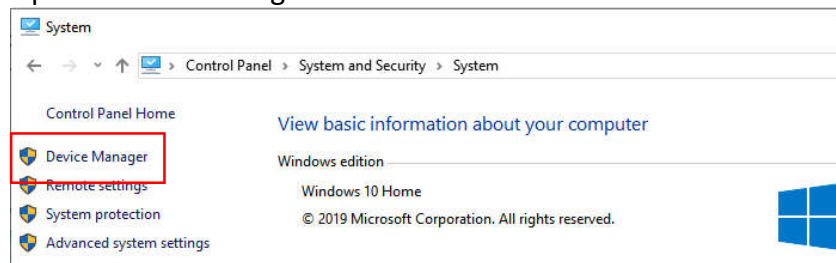

4. Select and open “Smart card readers”

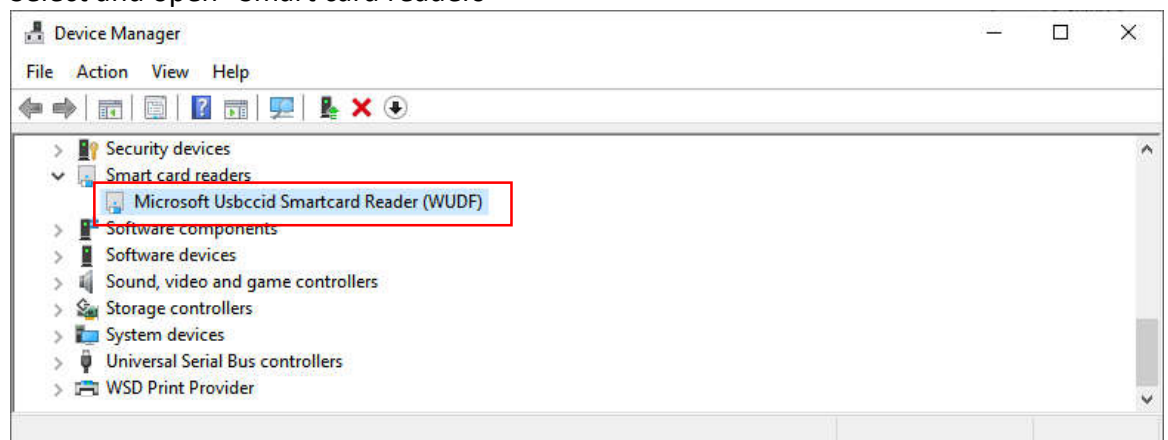

if it is shown “Microsoft Usbccid ... (WUDF)”, please continue with step 5)

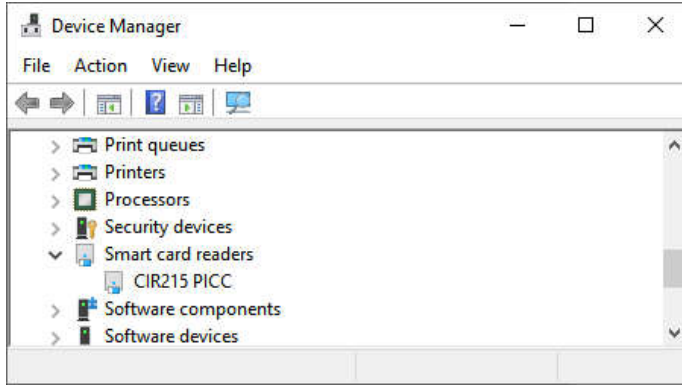

if it is shown “CIR215 PICC”, mean driver install completed

- Right click then select “Update driver”

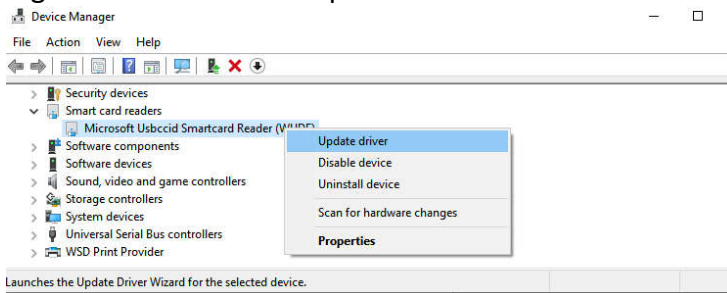

- Select “Browse my computer for driver software...”

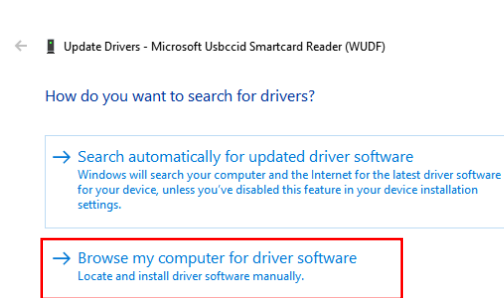

- 選擇 “Let me pick from a list ...”

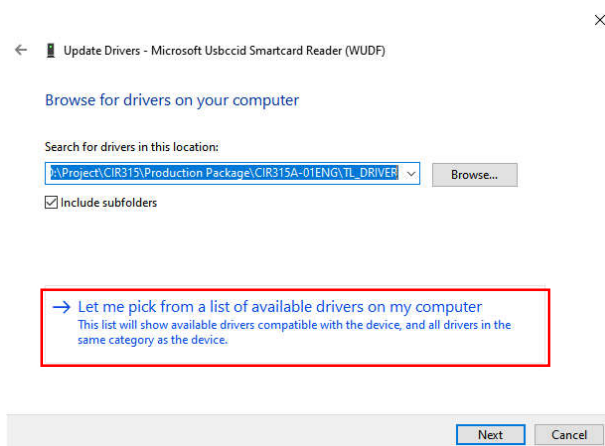

8. Select “Have Disk...”

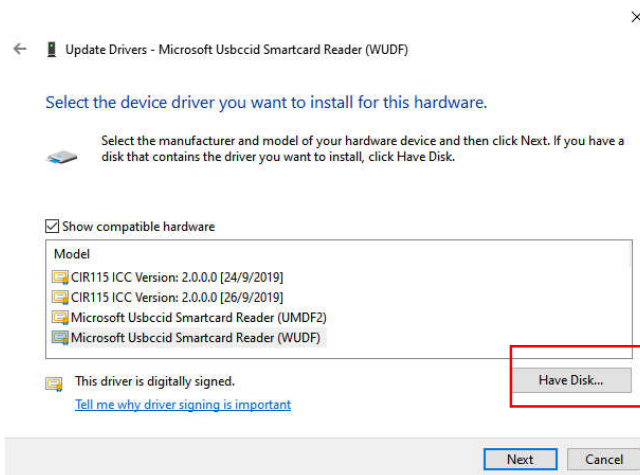

9. Select “Browse...”

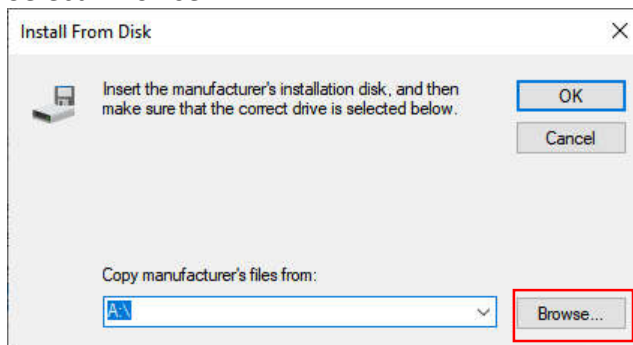

Select “CIR215.inf”, then press “Open” and “OK”

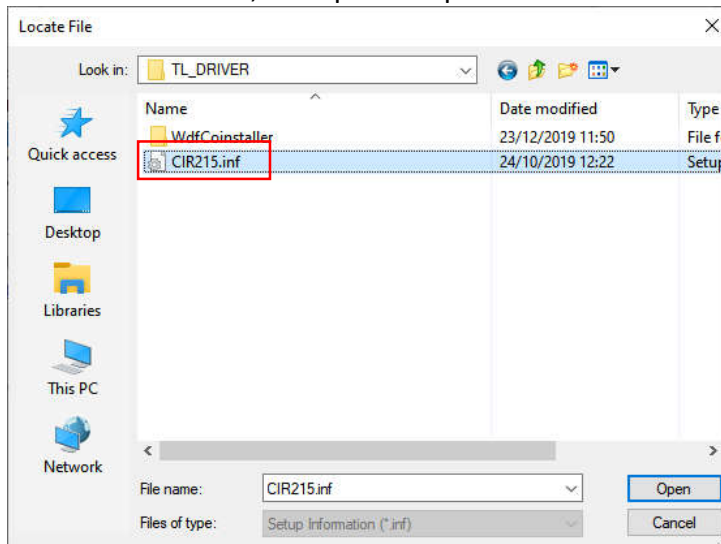

10. Select “CIR215 PICC” then “Next”

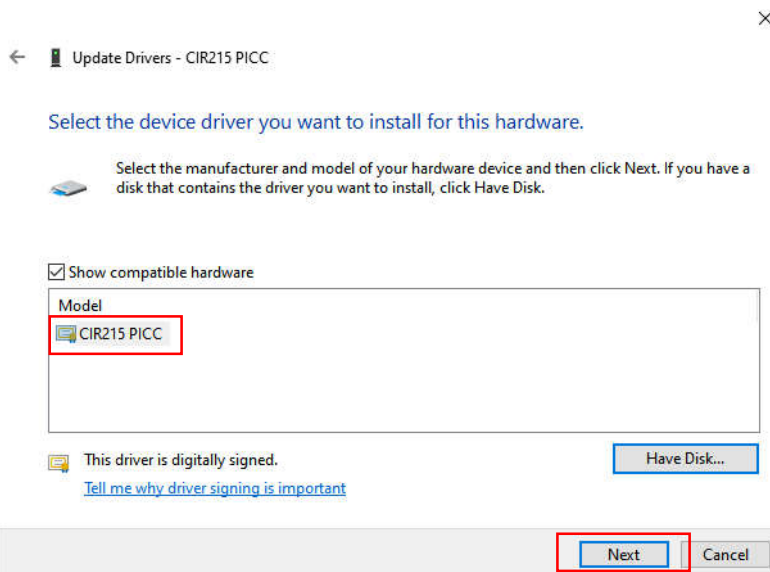

11. Waiting until below screen shown, Press “Close” to complete



12. Double click to ensure the device changed to “CIR215 PICC”

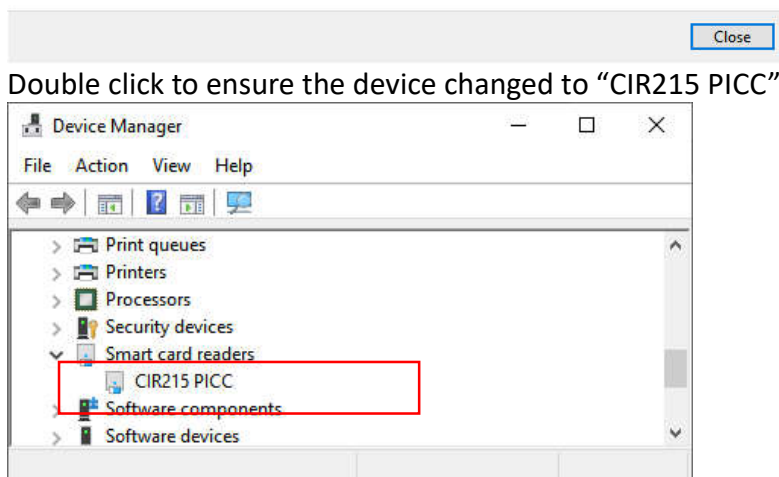

13. Done

Operation Example

Hardware requires:

- ❖ CIR215A
- ❖ PC with OS windows 7 or above
- ❖ ISO14443 Test Card

Software requires:

- ❖ Any PCSC Application (e.g. APDU.exe)

Steps:

1. Plug in the reader into the PC
2. Open “APDU.exe”

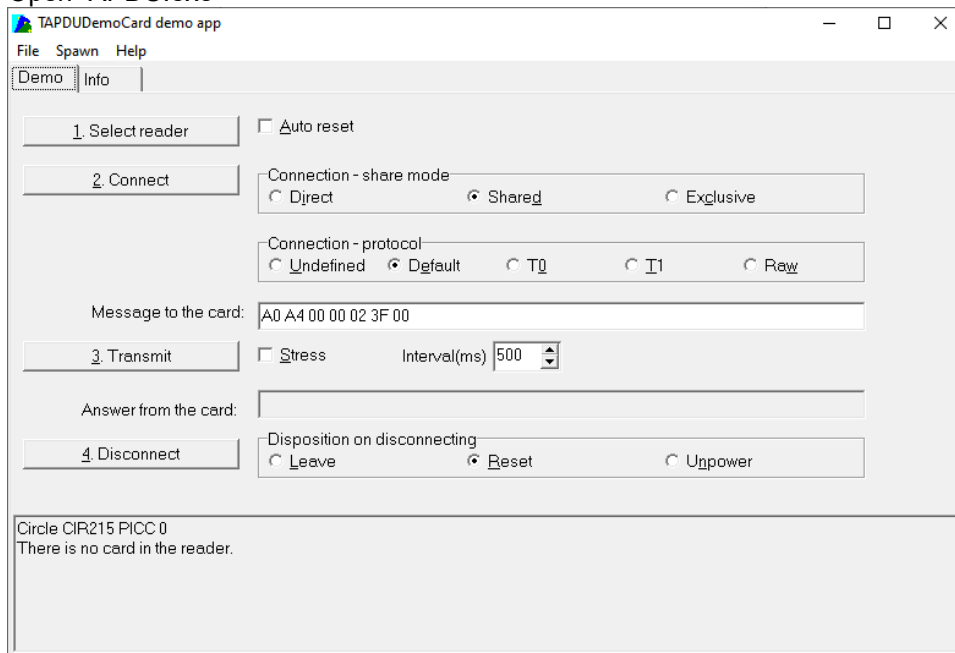

3. Click “1. Select reader”, Chose “Circle CIR215 PICC 0”, then click “OK”

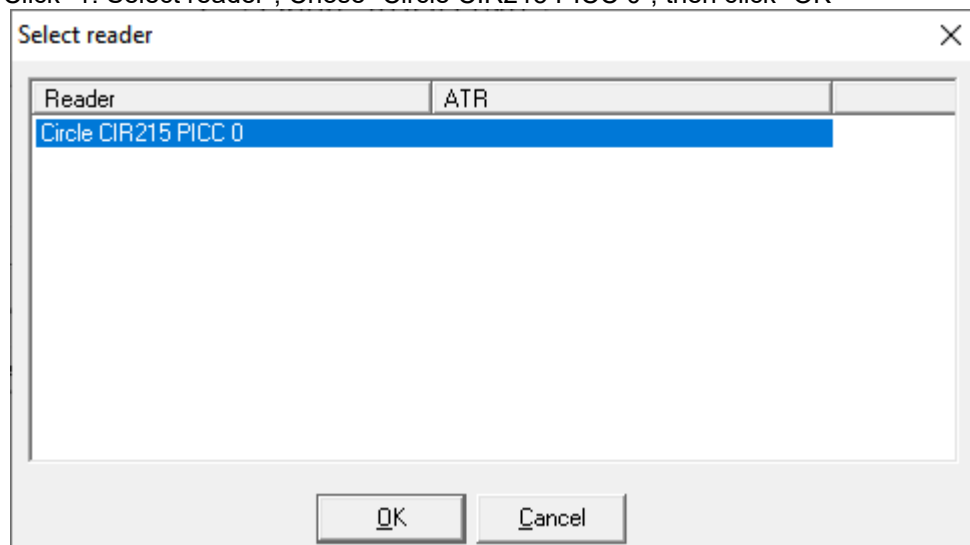

4. Tag ISO14443 Test card into CIR215A

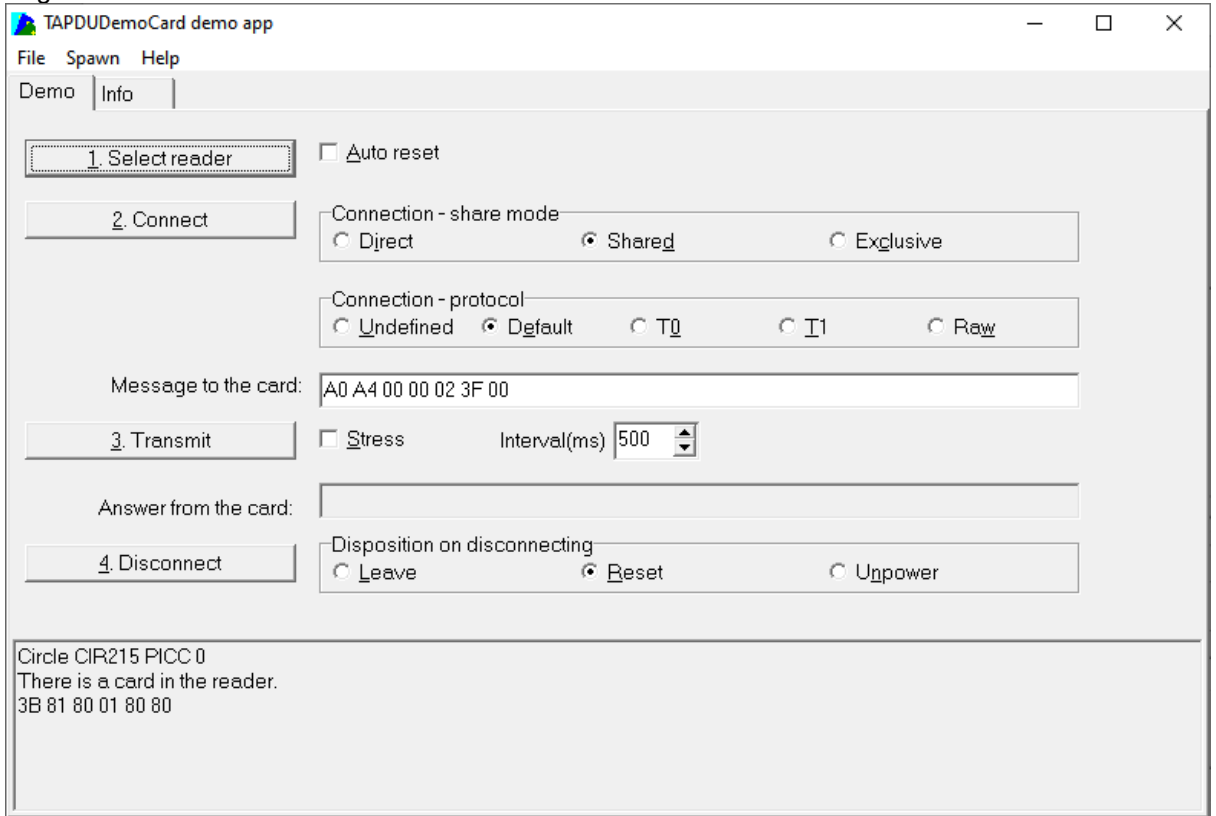

5. Select "T1", Message = "90 0a 00 00 01 00 00"

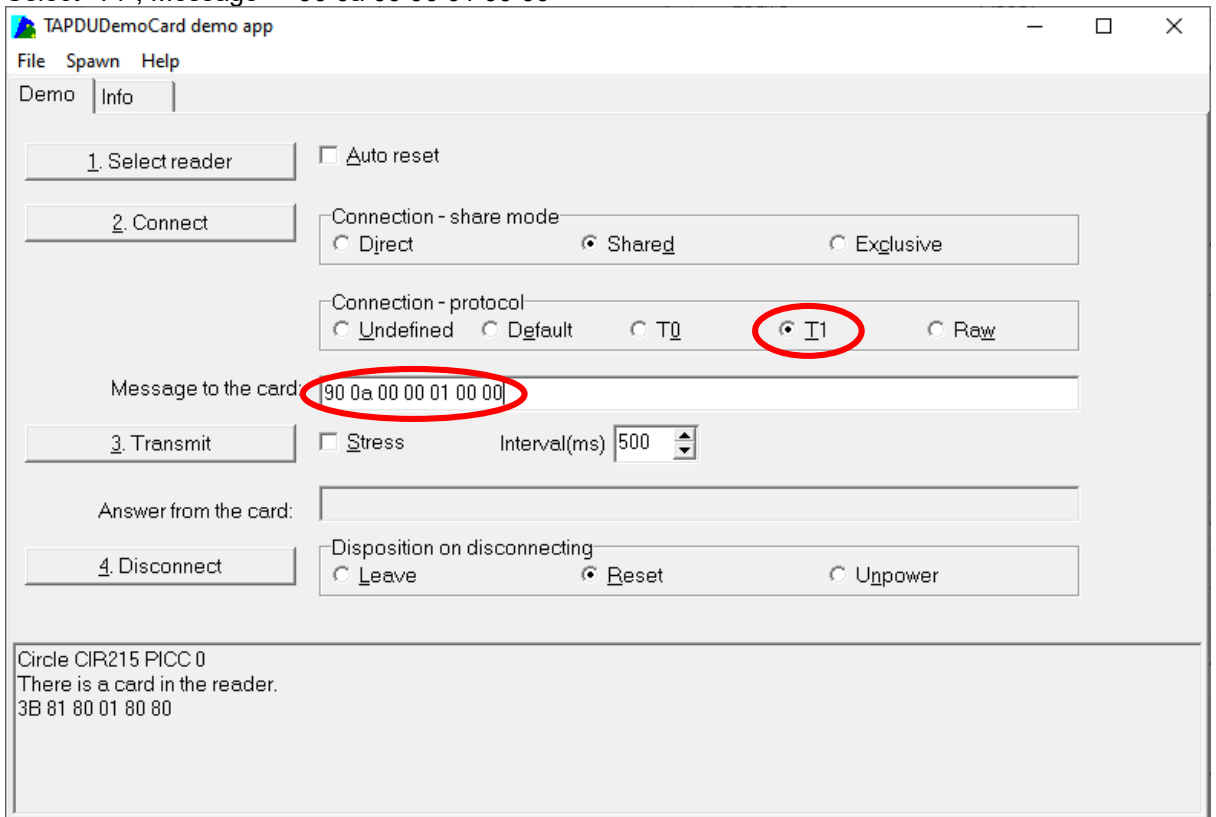

6. Press "2. Connect"

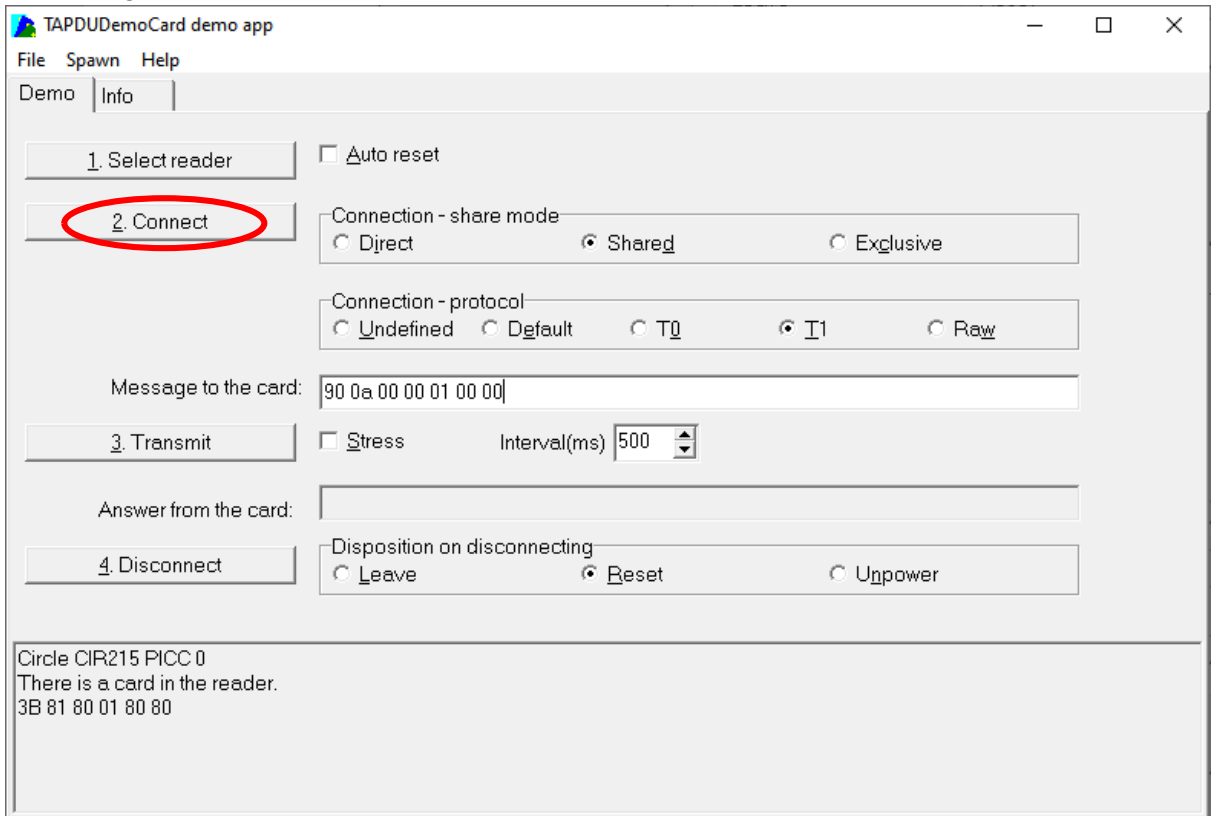

7. Press "3. Transmit"

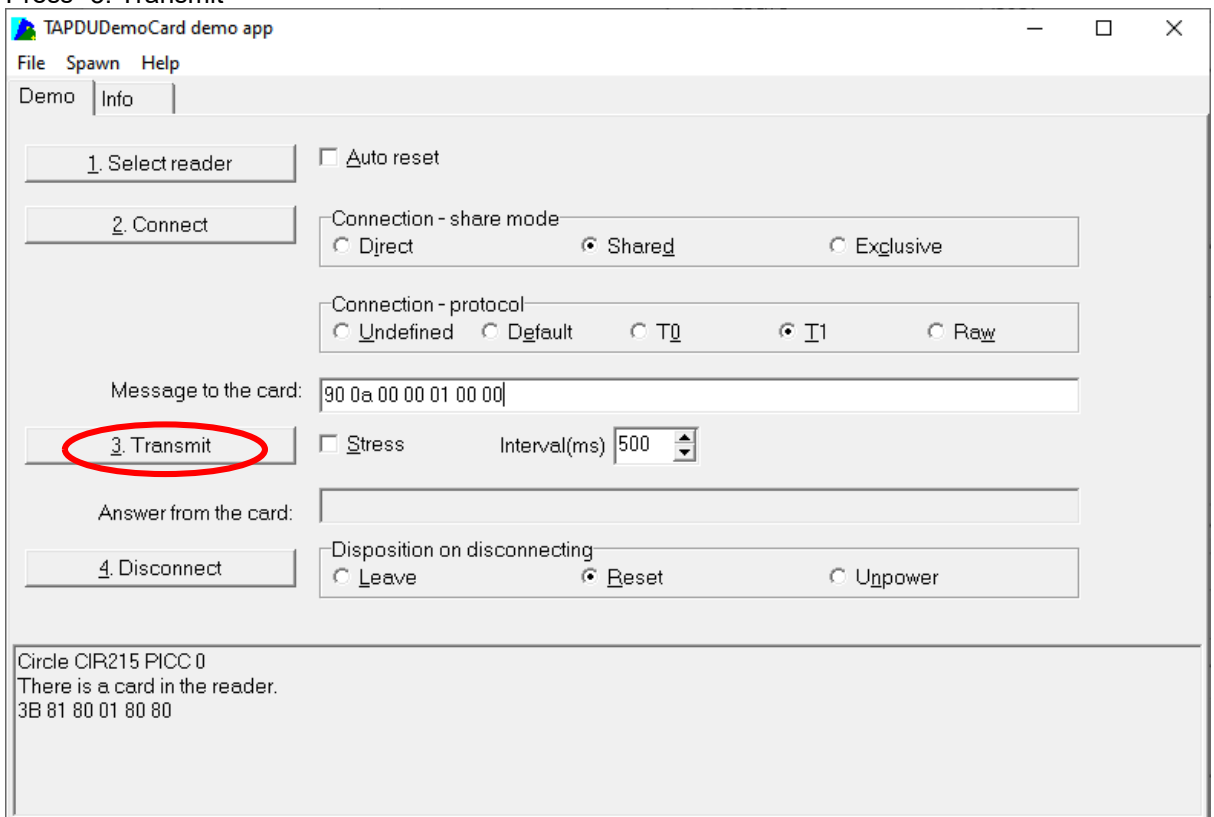

8. Result will be shown on the “Answer from the card:”

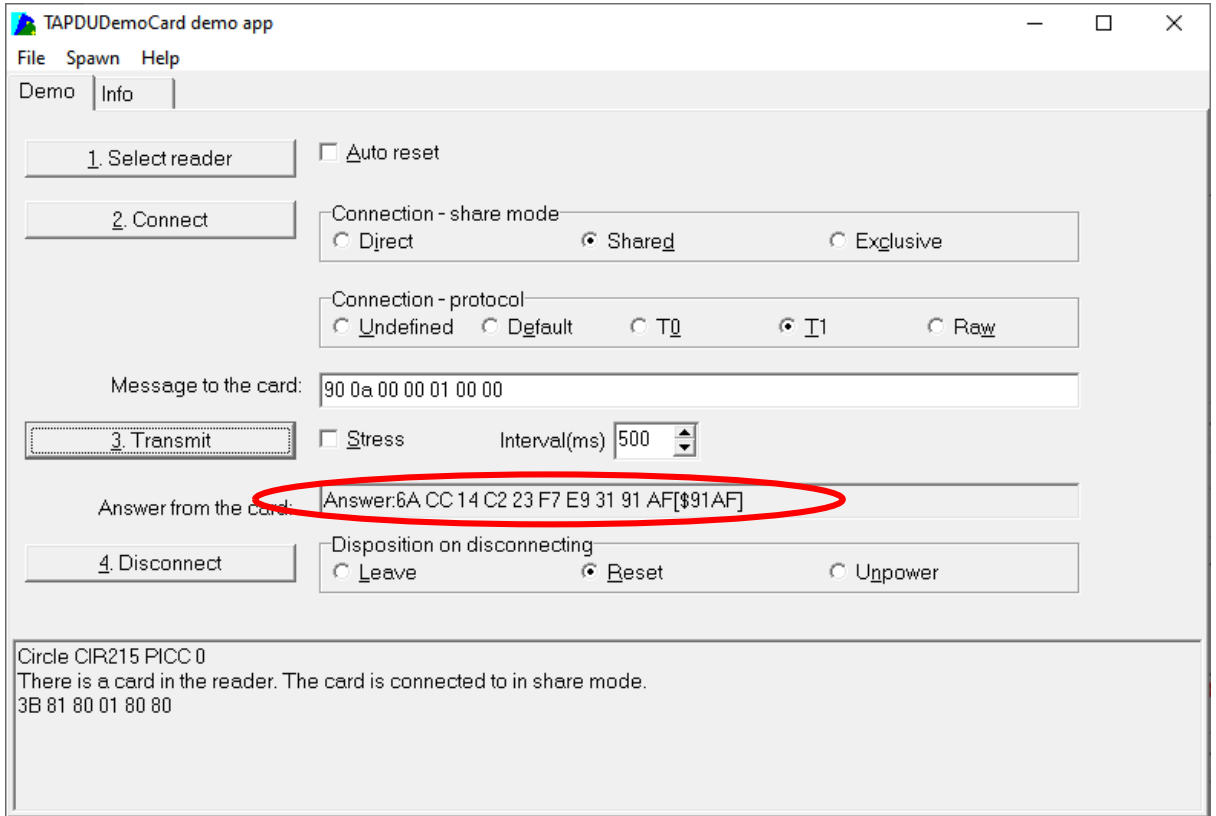

Parameter Sheet

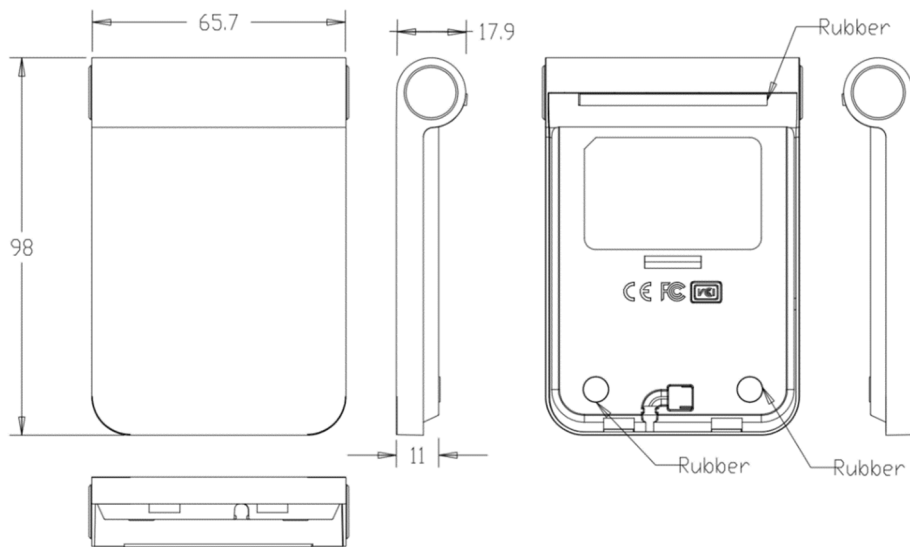

Physical Characteristics

Dimensions.....66 mm x 98 mm x 11 mm

CasingWhite and Grey ABS

Universal Serial Bus Interface

Specification.....USB 2.0

TypeFour lines: +5V, GND, D+ and D-

Speed.....USB 2.0 Full Speed Device, 12 Mbps

Supply VoltageRegulated 5V DC (Range from 4.75V to 5.25V)

Supply Current<200mA

Length1 m

Contactless Interface

Standard.....ISO/IEC 18092, ISO 14443 Type A & B, MIFARE, FeliCa

ProtocolT=CL for ISO14443-4-compliant cards, T=CL Emulation

.....for MIFARE Classic, ISO 18092, FeliCa and NFC tags

Carrier Frequency13.56MHz

Operating DistanceUp to 50mm (depending on card types)

Operating Baud Rate106kbps, 212kbps, 424kbps

Antenna Size53 mm x 44 mm



Human Interface

LED2 LED, 1 Blue (Operation Status), 1 Green (Power)

Operating Conditions

Temperature0 – 65 °C

Humidity<95%

Compliances/Certifications

Systems/ StandardsUSB 2.0 Full Speed, CCID, Microsoft® WHQL

Regulatory/ EnvironmentalEN 60950/IEC 60950, CE, FCC, VCCI, RoHS, REACH,
.....MIC

Operational Environment

Compatible Operating System Windows® 7, 8, 8.1, 10, Linux®, Mac OS® 10.11 and above,
Android™ 4.4 and above

Warning: Changes or modifications to this unit not expressly approved by the party responsible for compliance could void the user authority to operate the equipment.

NOTE: This equipment has been tested and found to comply with the limits for a Class B digital device, pursuant to Part 15 of the FCC Rules. These limits are designed to provide reasonable protection against harmful interference in a residential installation. This equipment generates, uses and can radiate radio frequency energy and, if not installed and used in accordance with the instructions, may cause harmful interference to radio communications. However, there is no guarantee that interference will not occur in a particular installation. If this equipment does cause harmful interference to radio or television reception, which can be determined by turning the equipment off and on, the user is encouraged to try to correct the interference by one or more of the following measures:

- Reorient or relocate the receiving antenna.
- Increase the separation between the equipment and receiver.
- Connect the equipment into an outlet on a circuit different from that to which the receiver is connected.
- Consult the dealer or an experienced radio/TV technician for help.