



# TEST REPORT

**Report Number :** 12778862 –E2V3

**Applicant :** Saankhya Labs Pvt Ltd  
Embassy Icon, Floor 3, No. 3 Infantry Road  
Bengaluru, Karnataka, 560 001  
IN

**Model :** Dhaval

**FCC ID :** 2AUUC-DHAVAL

**EUT Description :** UHF TVWS FIXED CLIENT STATION

**Test Standard(s) :** FCC 47 CFR PART 15 SUBPART H

**Date of Issue:**

December 4, 2019

**Prepared by:**

UL Verification Services Inc.  
47173 Benicia Street  
Fremont, CA 94538, U.S.A.  
TEL: (510) 319-4000  
FAX: (510) 661-0888



NVLAP LAB CODE 200065-0

Revision History

<u>Rev.</u>	<u>Issue Date</u>	<u>Revisions</u>	<u>Revised By</u>
V1	11/15/2019	Initial release	---
V2	11/20/19	Update the Applicant address	S. Kuwatani
V3	12/04/2019	Updated per TCB comments	F. de Anda

## TABLE OF CONTENTS

<b>1. ATTESTATION OF TEST RESULTS</b> .....	<b>5</b>
<b>2. SCOPE</b> .....	<b>7</b>
<b>3. TEST METHODOLOGY</b> .....	<b>7</b>
<b>4. FACILITIES AND ACCREDITATION</b> .....	<b>7</b>
<b>5. CALIBRATION AND UNCERTAINTY</b> .....	<b>8</b>
5.1. <i>MEASURING INSTRUMENT CALIBRATION</i> .....	8
5.2. <i>SAMPLE CALCULATION</i> .....	8
5.3. <i>MEASUREMENT UNCERTAINTY</i> .....	8
<b>6. EQUIPMENT UNDER TEST</b> .....	<b>9</b>
6.1. <i>DESCRIPTION OF EUT</i> .....	9
6.2. <i>DATABASE INFORMATION</i> .....	9
6.3. <i>MAXIMUM OUTPUT POWER</i> .....	9
6.4. <i>DESCRIPTION OF AVAILABLE ANTENNAS</i> .....	9
6.5. <i>SOFTWARE AND FIRMWARE</i> .....	9
6.6. <i>WORST-CASE CONFIGURATION AND MODE</i> .....	10
6.7. <i>DESCRIPTION OF TEST SETUP</i> .....	11
<b>7. TEST AND MEASUREMENT EQUIPMENT</b> .....	<b>16</b>
<b>8. MEASUREMENT METHODS</b> .....	<b>17</b>
<b>9. ANTENNA PORT TEST RESULTS</b> .....	<b>18</b>
9.1. <i>OUTPUT POWER AND POWER SPECTRAL DENSITY</i> .....	18
9.1.1. <i>UHF BAND</i> .....	19
9.2. <i>BAND-EDGE</i> .....	22
9.2.1. <i>UHF BAND</i> .....	23
9.3. <i>ADJACENT CHANNEL EMISSIONS</i> .....	27
9.3.1. <i>UHF BAND</i> .....	28
<b>10. RADIATED EMISSIONS</b> .....	<b>32</b>
10.1. <i>TRANSMITTER BELOW 1GHz</i> .....	33
10.1.1. <i>UHF BAND</i> .....	33
10.2. <i>TRANSMITTER ABOVE 1GHz</i> .....	39
10.2.1. <i>HARMONICS AND SPURIOUS EMISSIONS IN THE UHF BAND</i> .....	39
<b>11. AC MAINS LINE CONDUCTED EMISSIONS</b> .....	<b>45</b>
11.1. <i>UHF MODE</i> .....	46

---

11.1.1.	LINE 1 TX RESULTS.....	46
11.1.2.	LINE 2 TX RESULTS.....	47
<b>12.</b>	<b>FIXED CLIENT DATABASE CERTIFICATION TESTS .....</b>	<b>48</b>
12.1.	<i>Fixed WSD Registration -Client.....</i>	48
12.1.1.	SUCCESSFUL REGISTRATION .....	50
12.1.2.	FAILED REGISTRATION – Location Coordinates .....	53
12.1.3.	FAILED REGISTRATION – ANTENNA HEIGHT AGL.....	56
12.1.4.	FAILED REGISTRATION –CONTACT INFORMATION.....	57
12.2.	<i>FIXED WSD CHANNELS OF OPERATION.....</i>	59
12.3.	<i>FIXED TVDB DATABASE UPDATE.....</i>	62
12.4.	<i>48 HOUR CHANNEL SCHEDULING .....</i>	65
12.4.1.	RESULTS FOR CLIENT .....	66
12.5.	<i>WSD CHANNEL AVAILABILITY .....</i>	69
12.6.	<i>SECURITY.....</i>	71
12.7.	<i>Push notification to Fixed.....</i>	73
12.8.	<i>Location accuracy.....</i>	74
12.9.	<i>Interference protection requirement .....</i>	75
12.10.	<i>Fixed Power level reduction .....</i>	84
<b>13.</b>	<b>SETUP PHOTOS.....</b>	<b>86</b>

## 1. ATTESTATION OF TEST RESULTS

**COMPANY NAME:** Saankhya Labs Pvt Ltd  
Embassy Icon, Floor 3, No. 3 Infantry Road  
Bengaluru, Karnataka, 560 001  
IN

**EUT DESCRIPTION:** UHF TVWS FIXED CLIENT STATION

**MODEL:** Dhaval

**SERIAL NUMBER:** SLC-631F-1904-3095, SLC-631F-1904-308E

**DATE TESTED:** 10/22/2019 – 11/1/2019

APPLICABLE STANDARDS	
STANDARD	TEST RESULTS
FCC PART 15 SUBPART H	Complies

UL Verification Services Inc. tested the above equipment in accordance with the requirements set forth in the above standards. The test results show that the equipment tested is capable of demonstrating compliance with the requirements as documented in this report.

The results documented in this report apply only to the tested sample, under the conditions and modes of operation as described herein. It is the manufacturer's responsibility to assure that additional production units of this model are manufactured with identical electrical and mechanical components. All samples tested were in good operating condition throughout the entire test program. Measurement Uncertainties are published for informational purposes only and were not taken into account unless noted otherwise.

This document may not be altered or revised in any way unless done so by UL Verification Services Inc. and all revisions are duly noted in the revisions section. Any alteration of this document not carried out by UL Verification Services Inc. will constitute fraud and shall nullify the document. This report must not be used by the client to claim product certification, approval, or endorsement by NVLAP, NIST, any agency of the Federal Government, or any agency of the U.S. government.

Approved & Released For  
UL Verification Services Inc. By:

Prepared By:



---

Francisco de Anda  
Project Engineer/Operations Leader  
CONSUMER TECHNOLOGY DIVISION  
UL Verification Services Inc.

---

Eric Yu  
Test Engineer  
CONSUMER TECHNOLOGY DIVISION  
UL Verification Services Inc.

Reviewed By:



---

Henry Lau  
Project Engineer  
Consumer Technology Division  
UL Verification Services Inc.

## 2. SCOPE

This report documents the results of RF, emissions and database tests for a TVWS Fixed Client Station. This report will demonstrate compliance to the applicable rules in Part 15 Subpart H – White Space Devices.

## 3. TEST METHODOLOGY

The tests documented in this report were performed in accordance with FCC CFR 47 Part 15 Subpart H, KDB 416721 D01 v03, and ANSI C63.10-2013.

## 4. FACILITIES AND ACCREDITATION

The test sites and measurement facilities used to collect data are located at 47173 and 47266 Benicia Street, and 47658 Kato Road, Fremont, California, USA. Line conducted emissions are measured only at the 47173 address. The following table identifies which facilities were utilized for radiated emission measurements documented in this report. Specific facilities are also identified in the test results sections.

47173 Benicia Street	47266 Benicia Street	47658 Kato Rd
<input type="checkbox"/> Chamber A	<input type="checkbox"/> Chamber D	<input checked="" type="checkbox"/> Chamber I
<input type="checkbox"/> Chamber B	<input type="checkbox"/> Chamber E	<input type="checkbox"/> Chamber J
<input type="checkbox"/> Chamber C	<input type="checkbox"/> Chamber F	<input type="checkbox"/> Chamber K
	<input type="checkbox"/> Chamber G	<input type="checkbox"/> Chamber L
	<input type="checkbox"/> Chamber H	<input type="checkbox"/> Chamber M

The above test sites and facilities are covered under FCC Test Firm Registration # 208313. Chambers above are covered under Industry Canada company address and respective code 2324A.

UL Verification Services Inc. is accredited by NVLAP, Laboratory Code 200065-0

## 5. CALIBRATION AND UNCERTAINTY

### 5.1. MEASURING INSTRUMENT CALIBRATION

The measuring equipment utilized to perform the tests documented in this report has been calibrated in accordance with the manufacturer's recommendations, and is traceable to recognized national standards.

### 5.2. SAMPLE CALCULATION

#### RADIATED EMISSIONS

Where relevant, the following sample calculation is provided:

Field Strength (dBuV/m) = Measured Voltage (dBuV) + Antenna Factor (dB/m) + Cable Loss (dB) – Preamp Gain (dB)

$$36.5 \text{ dBuV} + 18.7 \text{ dB/m} + 0.6 \text{ dB} - 26.9 \text{ dB} = 28.9 \text{ dBuV/m}$$

#### MAINS CONDUCTED EMISSIONS

Where relevant, the following sample calculation is provided:

Final Voltage (dBuV) = Measured Voltage (dBuV) + Cable Loss (dB) + Limiter Factor (dB) + LISN Insertion Loss.

$$36.5 \text{ dBuV} + 0 \text{ dB} + 10.1 \text{ dB} + 0 \text{ dB} = 46.6 \text{ dBuV}$$

### 5.3. MEASUREMENT UNCERTAINTY

Where relevant, the following measurement uncertainty levels have been estimated for tests performed on the apparatus:

Parameter	Uncertainty
Worst Case Conducted Disturbance, 9KHz to 0.15 MHz	3.84 dB
Worst Case Conducted Disturbance, 0.15 to 30 MHz	3.65 dB
Worst Case Radiated Disturbance, 9KHz to 30 MHz	2.52 dB
Worst Case Radiated Disturbance, 30 to 1000 MHz	4.88 dB
Worst Case Radiated Disturbance, 1000 to 18000 MHz	4.24 dB
Worst Case Radiated Disturbance, 18000 to 26000 MHz	4.37 dB
Worst Case Radiated Disturbance, 26000 to 40000 MHz	5.17 dB

Uncertainty figures are valid to a confidence level of 95%.



## 6. EQUIPMENT UNDER TEST

### 6.1. DESCRIPTION OF EUT

The EUT is a UHF TVWS fixed Client Station.

Client Station is identical in hardware to the Base Station. The difference is in the antenna type and gain, software configuration and deployment location.

Antenna port conducted tests are performed on model Meghdoot (FCC ID: 2AUUC-MEGHDOOT) and the data is leveraged for model Dhaval (2AUUC-DHAVAL) with the addition of a different antenna type and gain.

### 6.2. DATABASE INFORMATION

Nominet is the TVWS Database provider, referred to as the TVWS Database throughout this report.

### 6.3. MAXIMUM OUTPUT POWER

The transmitter has a maximum output power as follows;

BAND	Frequency Range (MHz)	Conducted		EIRP	
		Output Power (dBm)	Output Power (mW)	Output Power (dBm)	Output Power (mW)
UHF	470 - 608	25.12	325.09	34.12	2582.26

### 6.4. DESCRIPTION OF AVAILABLE ANTENNAS

The client radio uses the following antenna type, and has the following antenna gain;

Type	Band	Gain
Log-Periodic (Yagi)	UHF	9 dBi

### 6.5. SOFTWARE AND FIRMWARE

The firmware installed in the EUT during testing was as follows

	Firmware revision
Dhaval (Client unit)	V5.1.9-fcc
TVWS Application	V1.0.10-fcc

Note, base and client stations firmware's are same, but differ in software configuration management system for given function, base or client.

## 6.6. WORST-CASE CONFIGURATION AND MODE

For power line conducted emissions were performed with the EUT set to transmit at the channel with the highest power and worst-case data rate as worst-case scenario.

Radiated emissions Below 30MHz were not performed on the EUT. Lowest clock or frequency used by the radio is 32MHz.

Radiated emissions from 30MHz to 1GHz and above 1GHz were performed with the EUT set to transmit at low middle and high channels.

All final radiated testing was performed with the EUT in the normal orientation as indicated by manufacturer.

Preliminary baseline tests were performed to determine worst case data rate:

- QPSK
- 16-QAM
- 64-QAM

The worst case data rate was determined to be QPSK.

## 6.7. DESCRIPTION OF TEST SETUP

### SUPPORT EQUIPMENT

Support Equipment List				
Description	Manufacturer	Model	Serial Number	FCC ID
AC Adapter	Mean Well	GSM60A48-P1J	No Serial #	DoC
Laptop 1	HP	EliteBook 840 G3	5CG7061F32	DoC
AC Adapter	HP	USNT-HP-19.5V	WDHML0AGC8N1B5	DoC
Laptop 2	HP	EliteBook 840 G2	5CG6075ORT	DoC
AC Adapter	HP	USNT-HP-19.5V	WCZTT0B1R5NA5W	DoC
Laptop 3	Lenovo	Think Pad L480	PF1H0N14	DoC
AC Adapter	Lenovo	ADLX45DLC2A	SA10E75792	DoC
Router	TP-Link	TL-WR841N	2159230001005	TE7WR841NX V10
GPS Sensor	Anand Technologies	AT-ANT-GPSGNSS-SMA-4	AT-GNSS-1610-000001	N/A
Direction Coupler	Mini Circuit	ZUDC10-83-S+	1913	N/A
20dB Attenuator	Mini Circuit	BW-N20W20+	1834	N/A
40dB Attenuator	Mini Circuit	BW-N40W5+	1638	N/A

### I/O CABLES (RADIATED)

I/O Cable List						
Cable No	Port	# of identical ports	Connector Type	Cable Type	Cable Length (m)	Remarks
1	AC	1	AC	Un-shielded	0.2	to AC/DC Adapter
2	DC	1	DC	Un-shielded	1	to POE
3	DC	1	Ethernet	Un-shielded	0.2	DC to POE
4	Ethernet	1	RJ45	Un-shielded	1.8	POE to EUT
5	N-Type	1	N-type	Un-shielded	0.8	EUT to Antenna
6	N-Type	1	N-type	Un-shielded	0.5	EUT to GPS

**I/O CABLES (AC LINE CONDUCTED)**

I/O Cable List						
Cable No	Port	# of identical ports	Connector Type	Cable Type	Cable Length (m)	Remarks
1	AC	1	AC	Un-shielded	0.2	to AC/DC Adapter
2	DC	1	DC	Un-shielded	1	to Laptop
3	AC	1	AC	Un-shielded	0.6	AC to Router
4a	Ethernet	1	RJ45	Un-shielded	1	Laptop to Router
4b	Ethernet	1	RJ45	Un-shielded	1	POE to Router
4c	Ethernet	1	RJ45	Un-shielded	1.2	POE to EUT
4d	Ethernet	1	RJ45	Un-shielded	1.2	POE to EUT
5	AC	1	AC	Un-shielded	0.2	to AC/DC Adapter
6	DC	1	DC	Un-shielded	1	to POE
7	DC	1	Ethernet	Un-shielded	0.2	DC to POE
8	N-Type	1	N-type	Un-shielded	1	EUT to GPS
9	N-Type	1	N-type	Un-shielded	1	EUT to Attenuator
10	N-Type	1	N-type	Un-shielded	1	Attenuator to Client

**I/O CABLES (DATABASE)**

I/O Cable List						
Cable No	Port	# of identical ports	Connector Type	Cable Type	Cable Length (m)	Remarks
1a	Ethernet	1	RJ45	Un-shielded	0.8	EUT to Router
1b	Ethernet	1	RJ45	Un-shielded	0.8	Base Laptop to Router
1c	Ethernet	1	RJ45	Un-shielded	0.8	Router to Internet
1d	DC	1	RJ45	Un-shielded	0.8	Client Device to Laptop
2a	N-type	1	N-Type	Un-shielded	0.7	EUT to Coupler
2b	N-type	1	N-Type	Un-shielded	0.7	Client Device to Coupler
3	SMA	1	SMA	Un-shielded	1m	Coupler to Analyzer

**TEST SETUP**

The customer provided test software to exercise the EUT during tests.

The EUT was setup for four types of tests: Radiated emissions, AC.Line conducted emissions and Database testing. See below diagrams for configurations.

**SETUP DIAGRAM FOR RADIATED EMISSIONS TESTS**

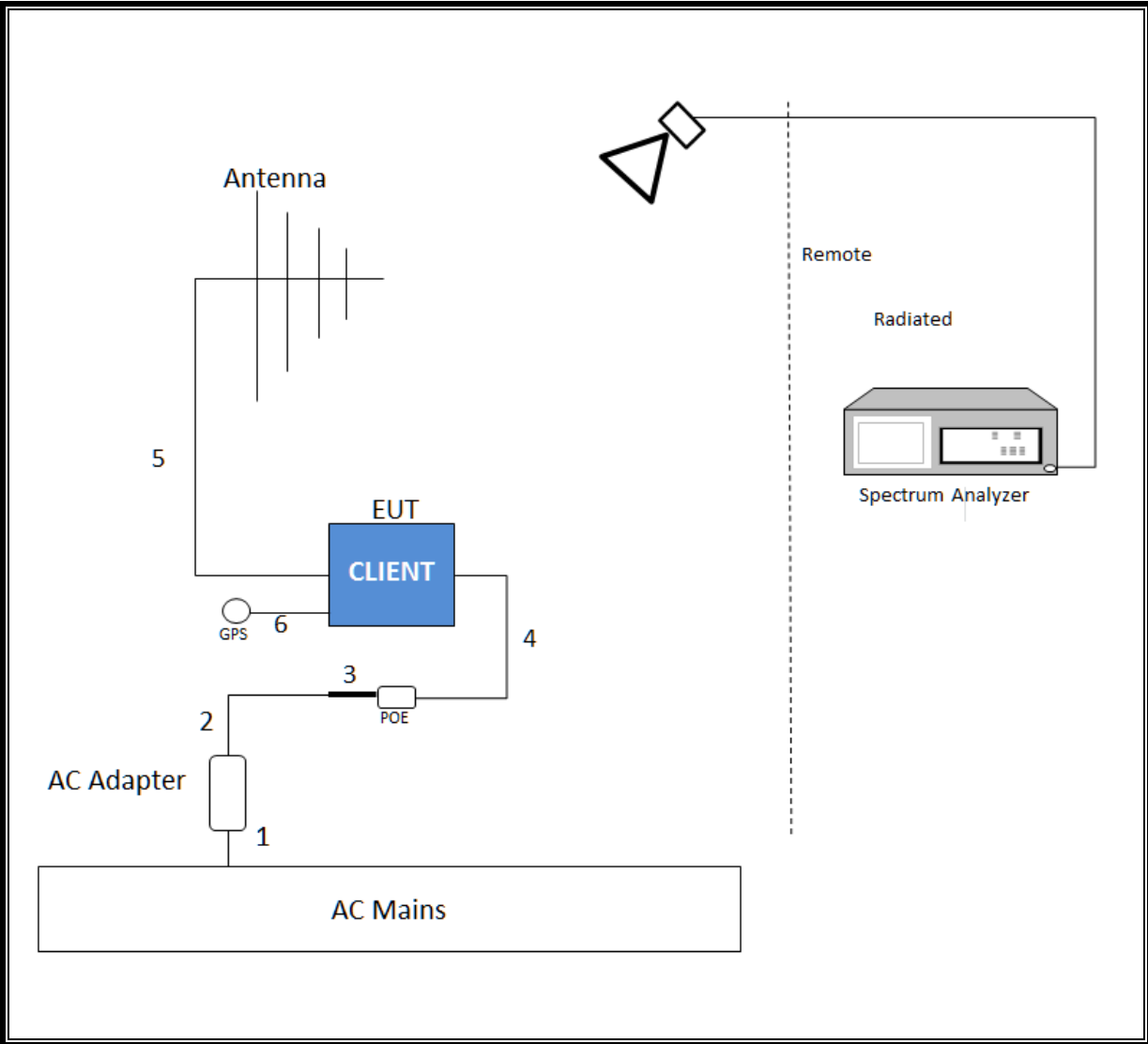



**SETUP DIAGRAM FOR DATABASE TESTS**

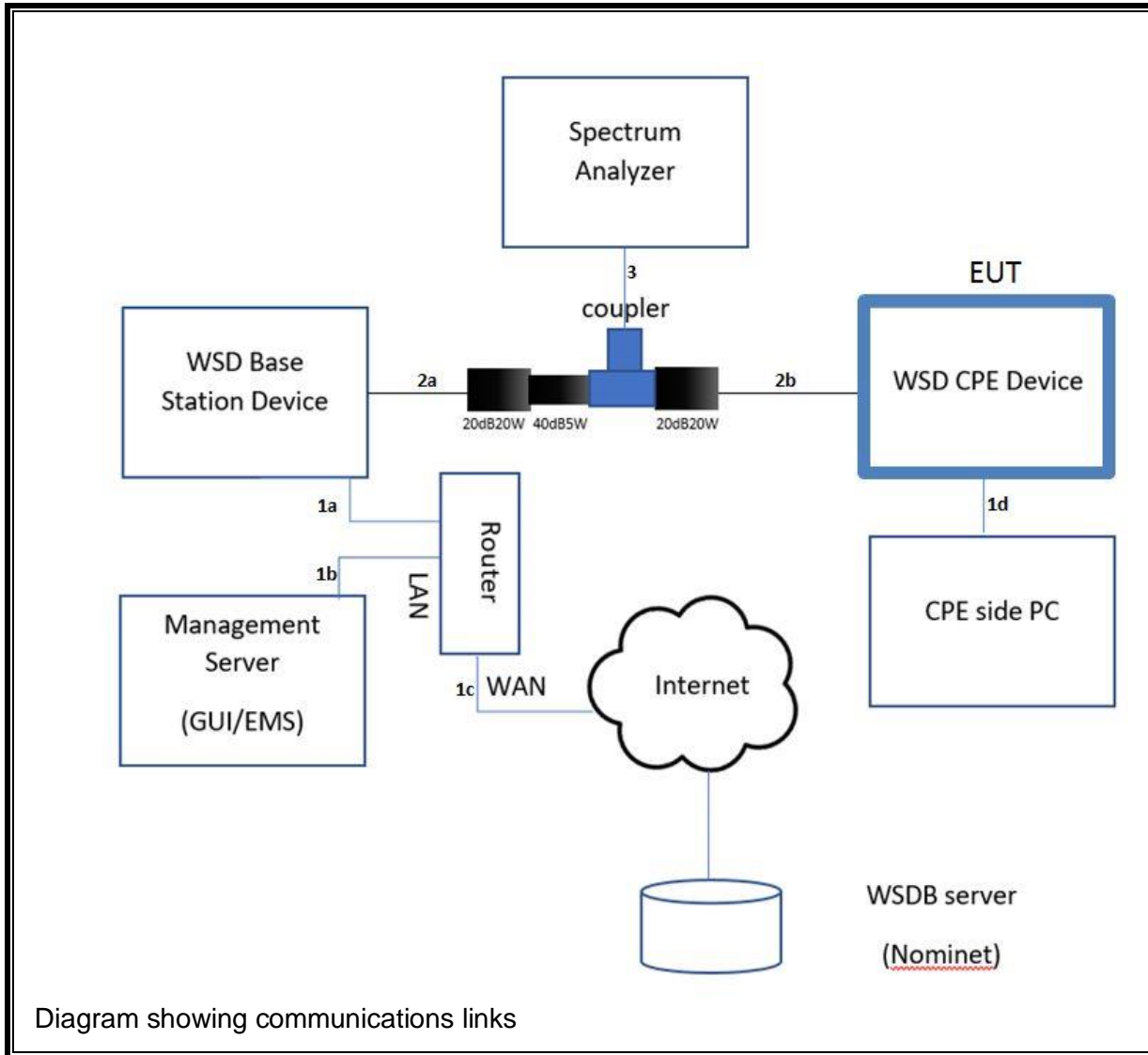

## 7. TEST AND MEASUREMENT EQUIPMENT

The following test and measurement equipment was utilized for the tests documented in this report:

TEST EQUIPMENT LIST					
Description	Manufacturer	Model	ID Num	Cal Due	Last Cal
Horn Antenna	ETS-Lindgren	3117	T862	06/05/2020	06/05/2019
Amplifier, 1 to18GHz	MITEQ	AFS42-00101800-25-S-42	PRE0181078	08/24/2020	08/24/2019
Antenna, Broadband Hybrid, 30MHz to 3GHz	Sunol Sciences Corp.	JB3	PRE0184971	11/13/2019	11/13/2018
Amplifier, 9kHz to 1GHz, 32 dB	Sonoma Instrument	310	PRE0180175	06/29/2020	06/29/2019
EMI Test Receiver	Rohde & Schwarz	ESW44	PRE0179376	2/14/2020	2/14/2019
Spectrum Analyzer, PSA, 3Hz to 26.5GHz	Agilent (Keysight) Technologies	E4440A	T200	1/28/2020	1/29/2019
Spectrum Analyzer, PSA, 3Hz to 26.5GHz	Agilent (Keysight) Technologies	E4440A	T908	1/29/2020	1/29/2019
Spectrum Analyzer, PSA, 3Hz to 26.5GHz	Agilent (Keysight) Technologies	E4440A	T198	1/29/2020	1/29/2019
587 MHz Notch Filter	EWT	EWT-14-0338	T239	08/07/2020	08/07/2019
515MHz Notch Filter	EWT	EWT-14-0348	T241	08/07/2020	08/07/2019
473MHz Notch Filter	EWT	EWT-14-0337	T232	08/07/2020	08/07/2019
1GHz High Pass Filter	Micro-Tronics	HPM50115	PRE0182589	09/04/2020	09/04/2019
AC Line Conducted					
EMI Receiver	Rohde & Schwarz	ESR	T1436	02/14/2020	02/14/2019
LISN for Conducted Emissions CISPR-16	FCC INC.	FCC LISN 50/250	T1310	01/24/2020	01/24/2019
Test Software List					
Radiated Software	UL	UL EMC		Ver 9.5, June 15, 2019	
Antenna Port Software	UL	UL RF		Ver 2019.10.18	
AC Line Conducted Software	UL	UL EMC		Ver 9.5, May 26, 2015	



## **8. MEASUREMENT METHODS**

Output Power & Power Spectral Density (Fixed WSD): KDB 416721 D01 v03 Section II, (2)(c)(i).

Band-Edge Measurement: KDB 416721 D01 v03 Section II (2)(d)(i)

Adjacent Channel Emissions: KDB 416721 D01 v03 Section II (2)(d)(ii)

Beyond Adjacent Channel Emissions: ANSI C63.10, Section 6.5 and 6.6.

AC Power Line Conducted Emissions: ANSI C63.10-2013, Section 6.2.

## 9. ANTENNA PORT TEST RESULTS

### 9.1. OUTPUT POWER AND POWER SPECTRAL DENSITY

#### LIMITS

§15.709 (b)(1) Fixed White Space Device

For operation at EIRP levels of 36 dBm (4000 mW) or less, fixed white space devices may operate at EIRP levels between the values shown in the table provided that the conducted power and the conducted power spectral density (PSD) limits are linearly interpolated between the values shown and the adjacent channel emission limit of the higher value shown in the table is met. Operation at EIRP levels above 36 dBm (4000 mW) shall follow the requirements for 40 dBm (10,000 mW).

EIRP (6 MHz)	Conducted power limit <sup>1</sup> (6 MHz)	Conducted PSD limit (100 kHz)	Conducted adjacent channel emission limit (100 kHz)
16 dBm (40 mW)	10 dBm (10 mW)	-7.4 dBm	-62.8 dBm
20 dBm (100 mW)	14 dBm (25 mW)	-3.4 dBm	-58.8 dBm
24 dBm (250 mW)	18 dBm (63 mW)	0.6 dBm	-54.8 dBm
28 dBm (625 mW)	22 dBm (158 mW)	4.6 dBm	-50.8 dBm
32 dBm (1600 mW)	26 dBm (400 mW)	8.6 dBm	-46.8 dBm
36 dBm (4000 mW)	30 dBm (1000 mW)	12.6 dBm	-42.8 dBm
40 dBm (10000 mW)	30 dBm (1000 mW)	12.6 dBm	-42.8 dBm

<sup>1</sup>The conducted power spectral density from a fixed white space device shall not be greater than the values shown in the table when measured in any 100 kHz band during any time interval of continuous transmission, except that a 40 mW fixed white space device operating in a four megahertz channel within a seven megahertz guard band must comply with a conducted power spectral density limit of -5.4 dBm.

The conducted power, PSD and adjacent channel limits for fixed white space devices operating at up to 36 dBm (4000 milliwatts) EIRP shown in the table in paragraph (b)(1) of this section are based on a maximum transmitting antenna gain of 6 dBi. If transmitting antennas of directional gain greater than 6 dBi are used, the maximum conducted output power shall be reduced by the amount in dB that the directional gain of the antenna exceeds 6 dBi.

The conducted power, PSD and adjacent channel limits for fixed white space devices operating at greater than 36 dBm (4000 milliwatts) EIRP shown in the table in paragraph (b)(1) of this section are based on a maximum transmitting antenna gain of 10 dBi. If transmitting antennas of directional gain greater than 10 dBi are used, the maximum conducted output power shall be reduced by the amount in dB that the directional gain of the antenna exceeds 10 dBi.

**DIRECTIONAL ANTENNA GAIN**

There is only one transmitter output therefore the directional gain is equal to the antenna gain.

**RESULTS**

**9.1.1. UHF BAND**

<b>Tested By:</b>	16080ZS
<b>Test Date:</b>	11/1/2019

<b>Antenna Gain (dBi)</b>	9.00
---------------------------	------

**Output Power Results**

Channel	Frequency (MHz)	Measured Total Output Power (dBm)	Measured Total EIRP (dBm)	Conducted Power Limit (dBm)	Margin (dB)
Low	473	25.12	34.12	25.12	0.00
Mid	539	25.07	34.07	25.07	0.00
High	605	24.39	33.39	24.39	0.00

**PSD Results**

Channel	Frequency (MHz)	Measured Total PSD Power (dBm)	Conducted PSD Limit (dBm)	Margin (dB)
Low	473	7.34	10.72	-3.38
Mid	539	7.26	10.67	-3.41
High	605	6.60	9.99	-3.40

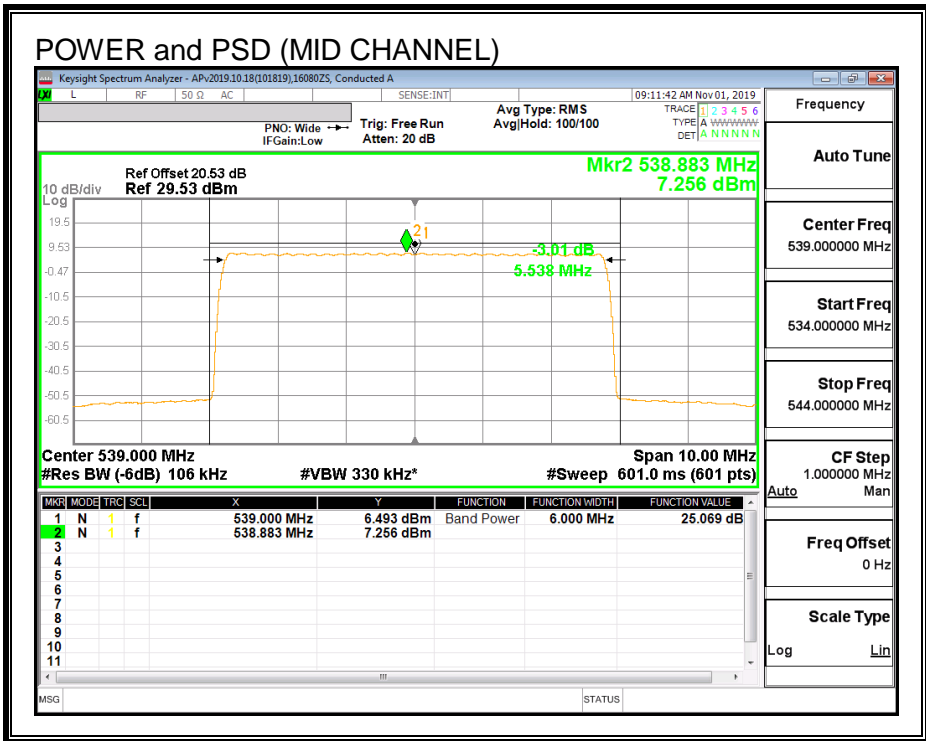
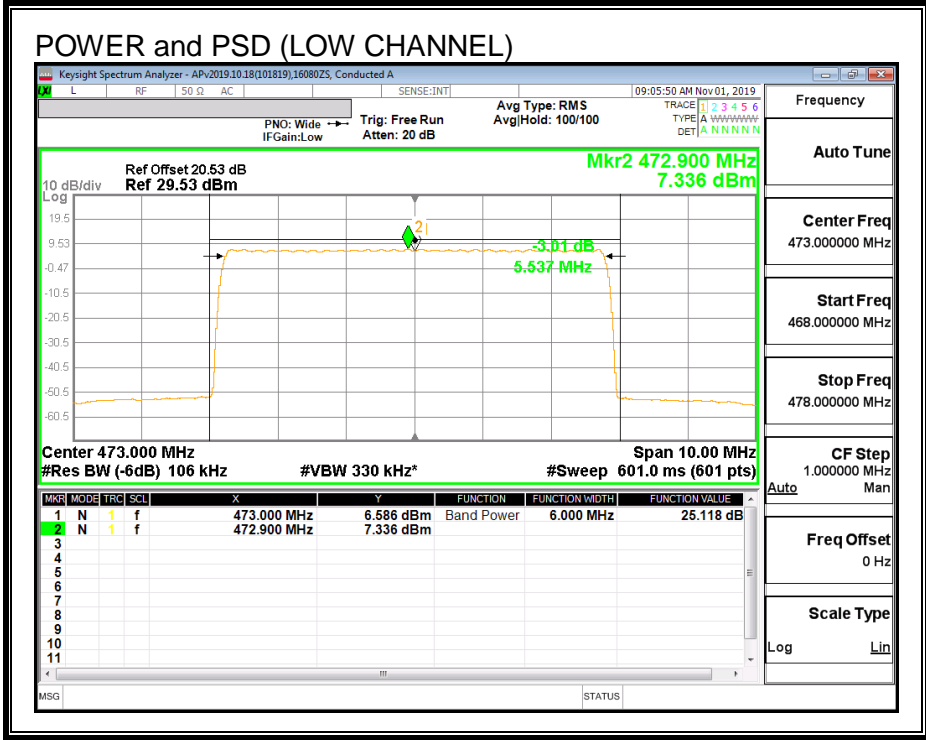

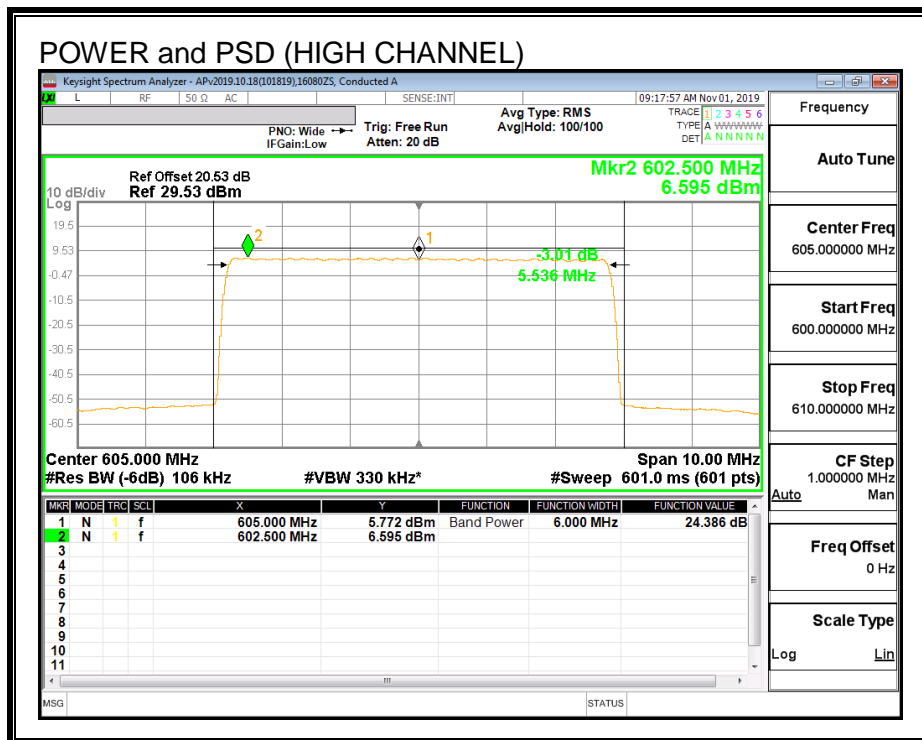

## 9.2. BAND-EDGE

### LIMITS

§15.709 (b)(1)(iii) Fixed White Space Device

EIRP (6 MHz)	Conducted power limit <sup>1</sup> (6 MHz)	Conducted PSD limit (100 kHz)	Conducted adjacent channel emission limit (100 kHz)
16 dBm (40 mW)	10 dBm (10 mW)	-7.4 dBm	-62.8 dBm
20 dBm (100 mW)	14 dBm (25 mW)	-3.4 dBm	-58.8 dBm
24 dBm (250 mW)	18 dBm (63 mW)	0.6 dBm	-54.8 dBm
28 dBm (625 mW)	22 dBm (158 mW)	4.6 dBm	-50.8 dBm
32 dBm (1600 mW)	26 dBm (400 mW)	8.6 dBm	-46.8 dBm
36 dBm (4000 mW)	30 dBm (1000 mW)	12.6 dBm	-42.8 dBm
40 dBm (10000 mW)	30 dBm (1000 mW)	12.6 dBm	-42.8 dBm

(d) Emission limits.(1) The adjacent channel emission limits shown in the tables in paragraphs (b)(1) and (2) of this section apply in the six megahertz channel immediately adjacent to each white space channel or group of contiguous white space channels in which the white space device is operating.

(2) At frequencies beyond the six megahertz channel immediately adjacent to each white space channel or group of contiguous white space channels in which the white space device is operating the white space device shall meet the requirements of §15.209.

(3) Emission measurements in the adjacent bands shall be performed using a minimum resolution bandwidth of 100 kHz with an average detector. A narrower resolution bandwidth may be employed near the band edge, when necessary, provided the measured energy is integrated to show the total power over 100 kHz.

Conducted Band edge limits for this Fixed WS device are: -46.8 dBm/100 kHz

Note: Adjacent channel emission limit of the higher value shown in the table above used

### RESULTS

### 9.2.1. UHF BAND

<b>Tested By:</b>	16080ZS
<b>Test Date:</b>	10/30/19

#### Lower Band-Edge Emissions

Channel	Frequency (MHz)	Measured Total Emission (dBm)	Emissions Limit (dBm)	Worst Case Margin (dBm)
Low	473	-51.52	-46.8	-4.72
Mid	539	-49.55	-46.8	-2.75
High	605	-49.09	-46.8	-2.29

#### Upper Band-Edge Emissions

Channel	Frequency (MHz)	Measured Total Emission (dBm)	Emissions Limit (dBm)	Worst Case Margin (dBm)
Low	473	-51.02	-46.8	-4.22
Mid	539	-49.25	-46.8	-2.45
High	605	-50.59	-46.8	-3.79

**LOW CHANNEL**

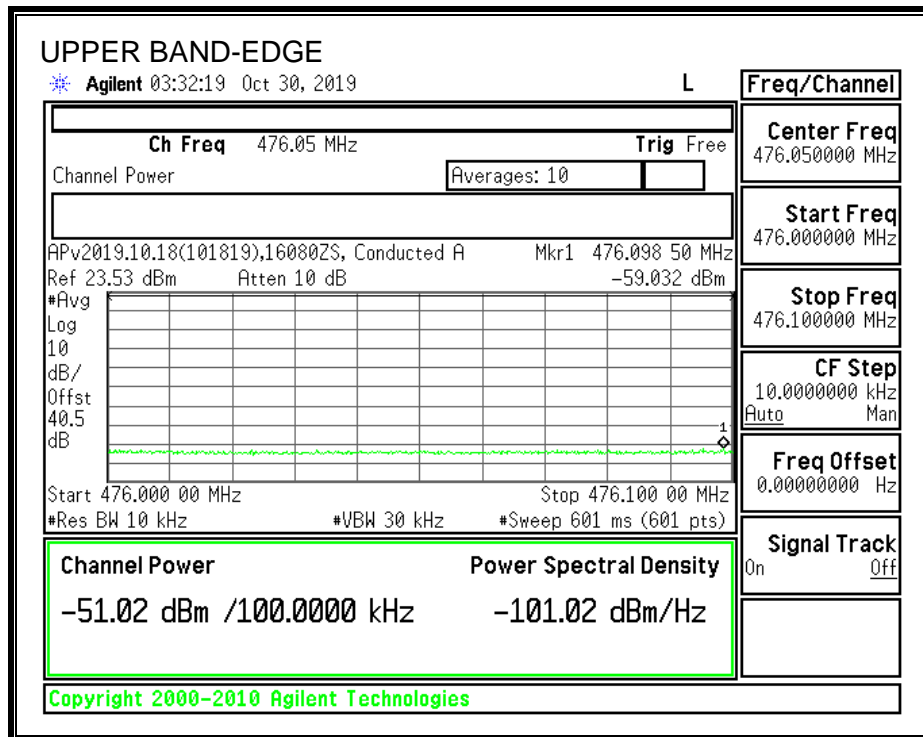
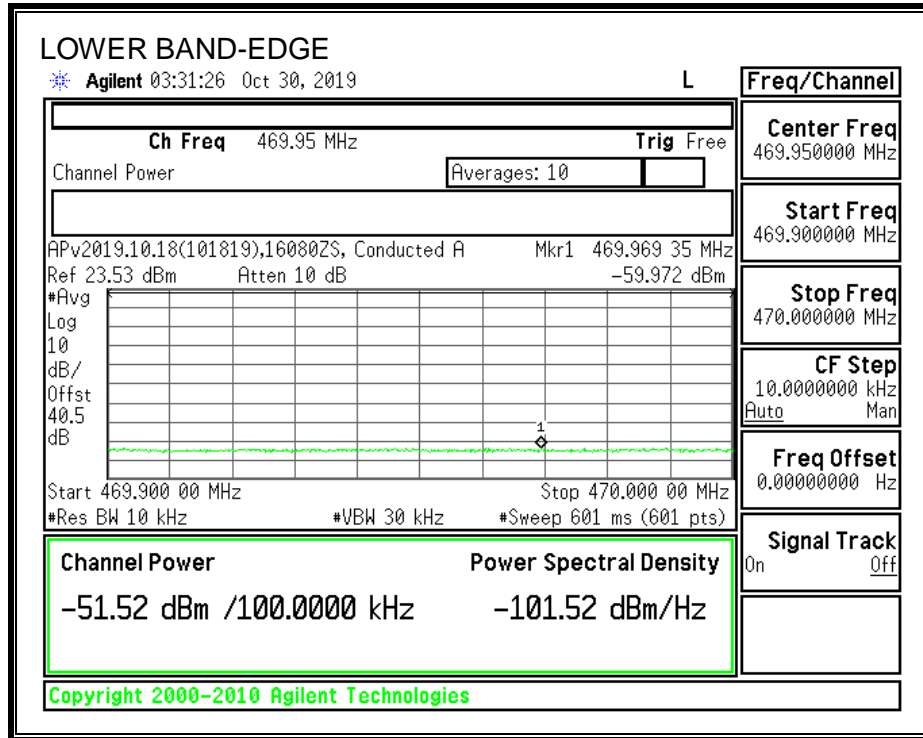



**MID CHANNEL**

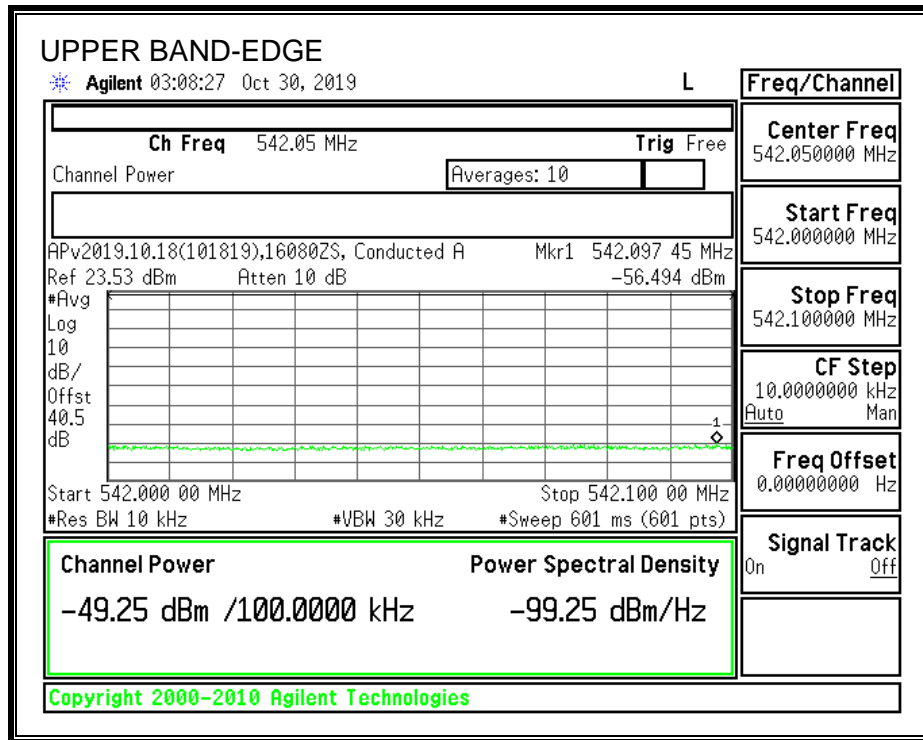
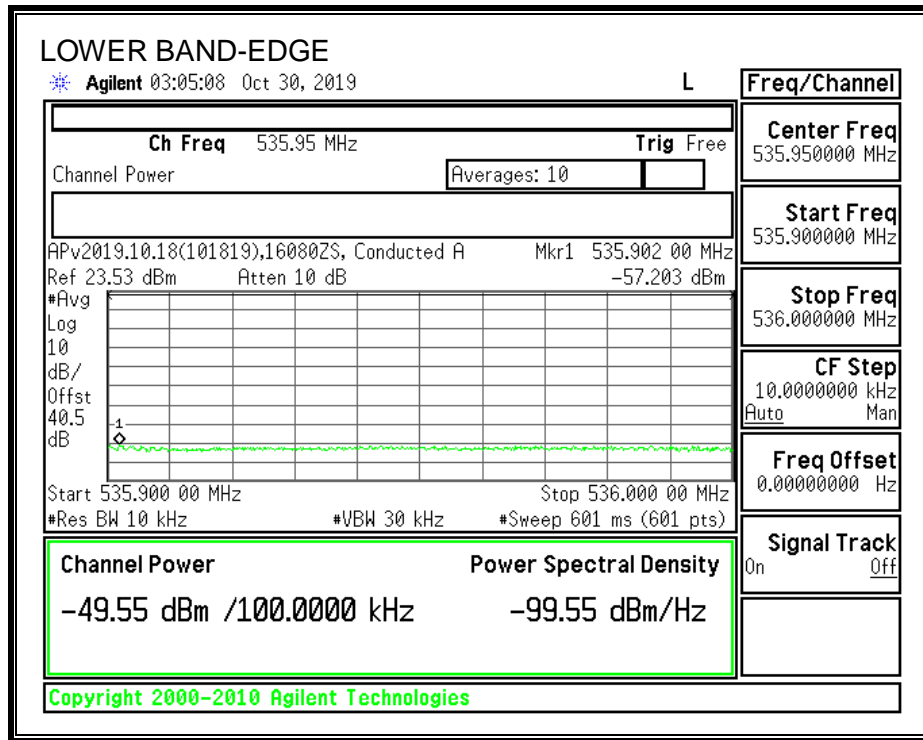

**HIGH CHANNEL**

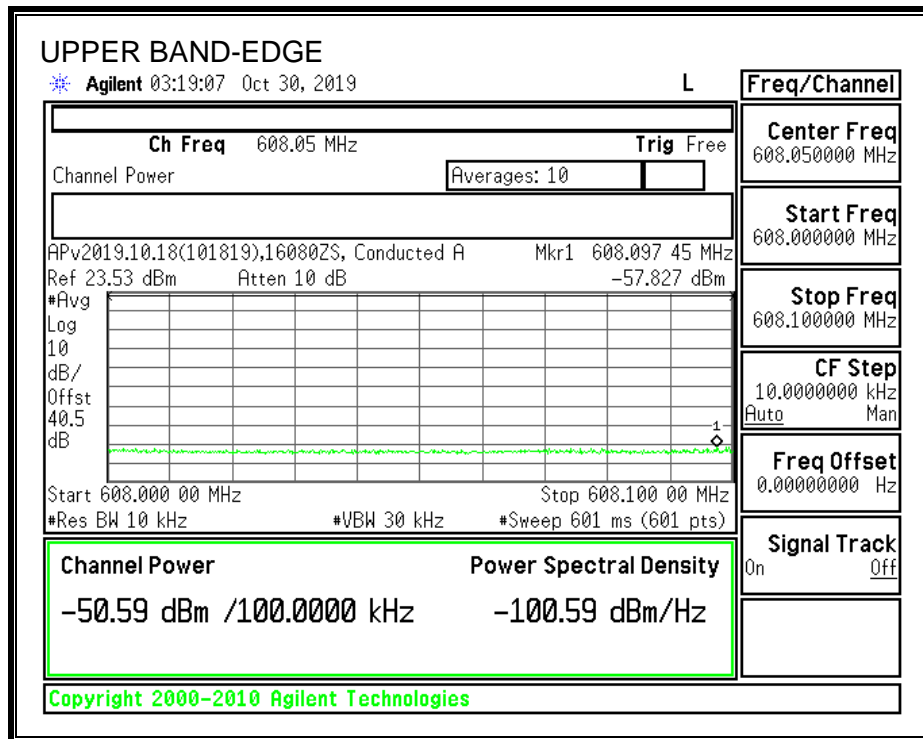
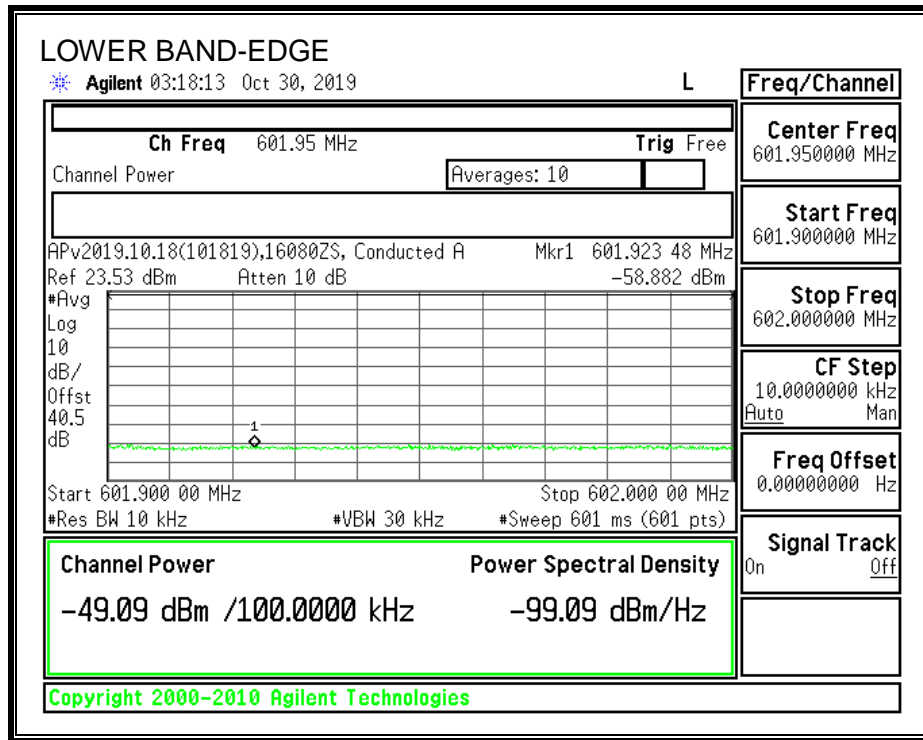

### 9.3. ADJACENT CHANNEL EMISSIONS

#### LIMITS

§15.709 Fixed White Space Device

(d) Emission limits.(1) The adjacent channel emission limits shown in the tables in paragraphs (b)(1) and (2) of this section apply in the six megahertz channel immediately adjacent to each white space channel or group of contiguous white space channels in which the white space device is operating.

EIRP (6 MHz)	Conducted power limit <sup>1</sup> (6 MHz)	Conducted PSD limit (100 kHz)	Conducted adjacent channel emission limit (100 kHz)
16 dBm (40 mW)	10 dBm (10 mW)	-7.4 dBm	-62.8 dBm
20 dBm (100 mW)	14 dBm (25 mW)	-3.4 dBm	-58.8 dBm
24 dBm (250 mW)	18 dBm (63 mW)	0.6 dBm	-54.8 dBm
28 dBm (625 mW)	22 dBm (158 mW)	4.6 dBm	-50.8 dBm
32 dBm (1600 mW)	26 dBm (400 mW)	8.6 dBm	-46.8 dBm
36 dBm (4000 mW)	30 dBm (1000 mW)	12.6 dBm	-42.8 dBm
40 dBm (10000 mW)	30 dBm (1000 mW)	12.6 dBm	-42.8 dBm

(2) At frequencies beyond the six megahertz channel immediately adjacent to each white space channel or group of contiguous white space channels in which the white space device is operating the white space device shall meet the requirements of §15.209.

(3) Emission measurements in the adjacent bands shall be performed using a minimum resolution bandwidth of 100 kHz with an average detector. A narrower resolution bandwidth may be employed near the band edge, when necessary, provided the measured energy is integrated to show the total power over 100 kHz.

Conducted Band edge limits for this Fixed WS device are: -46.8 dBm/100 kHz

Note: check limit -Adjacent channel emission limit of the higher value shown in the table above used

#### RESULTS

### 9.3.1. UHF BAND

<b>Tested By:</b>	16080ZS
<b>Test Date:</b>	10/30/19

#### Lower Adjacent Channel Emissions

Channel	Frequency (MHz)	Measured Total Emission (dBm)	Emissions Limit (dBm)	Worst Case Margin (dBm)
Low	473	-50.80	-46.8	-4.00
Mid	539	-48.61	-46.8	-1.81
High	605	-48.36	-46.8	-1.56

#### Upper Adjacent Channel Emissions

Channel	Frequency (MHz)	Measured Total Emission (dBm)	Emissions Limit (dBm)	Worst Case Margin (dBm)
Low	473	-50.40	-46.8	-3.60
Mid	539	-48.66	-46.8	-1.86
High	605	-50.18	-46.8	-3.38

**LOW CHANNEL**

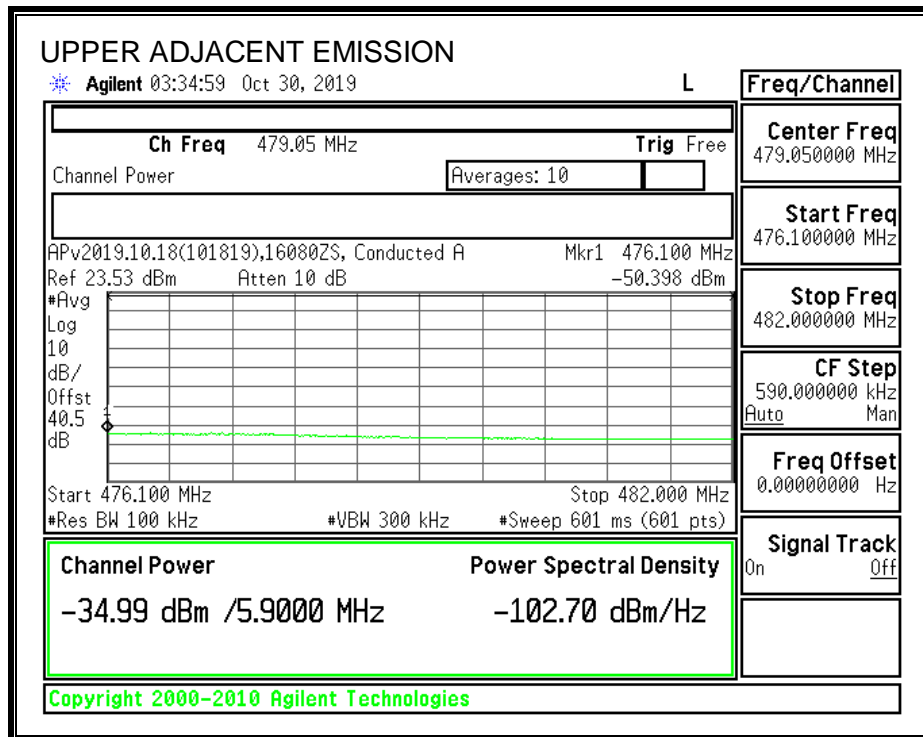
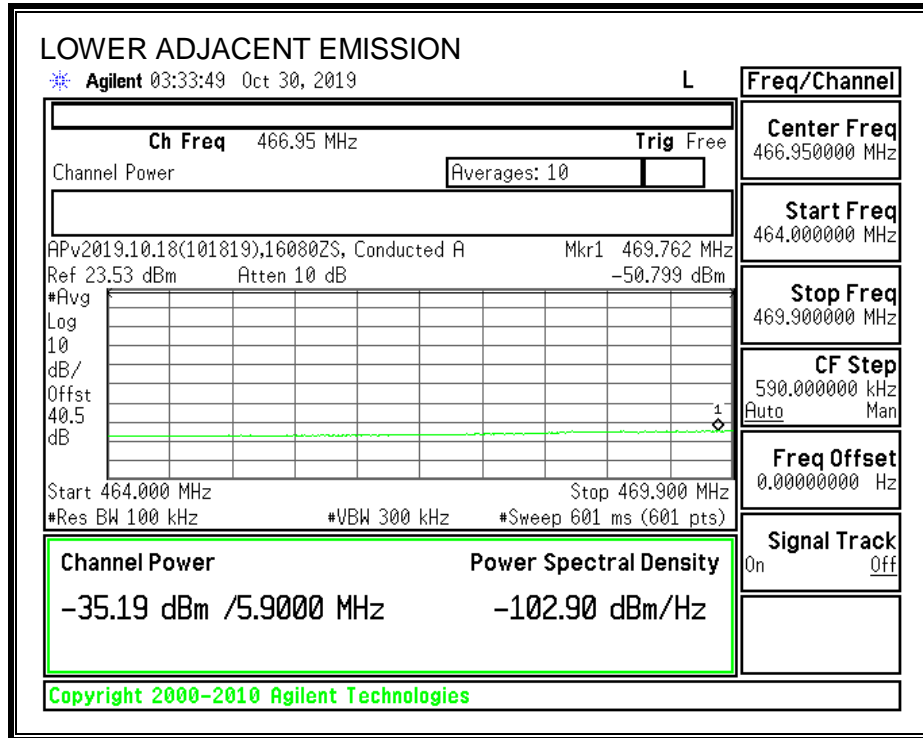

**MID CHANNEL**

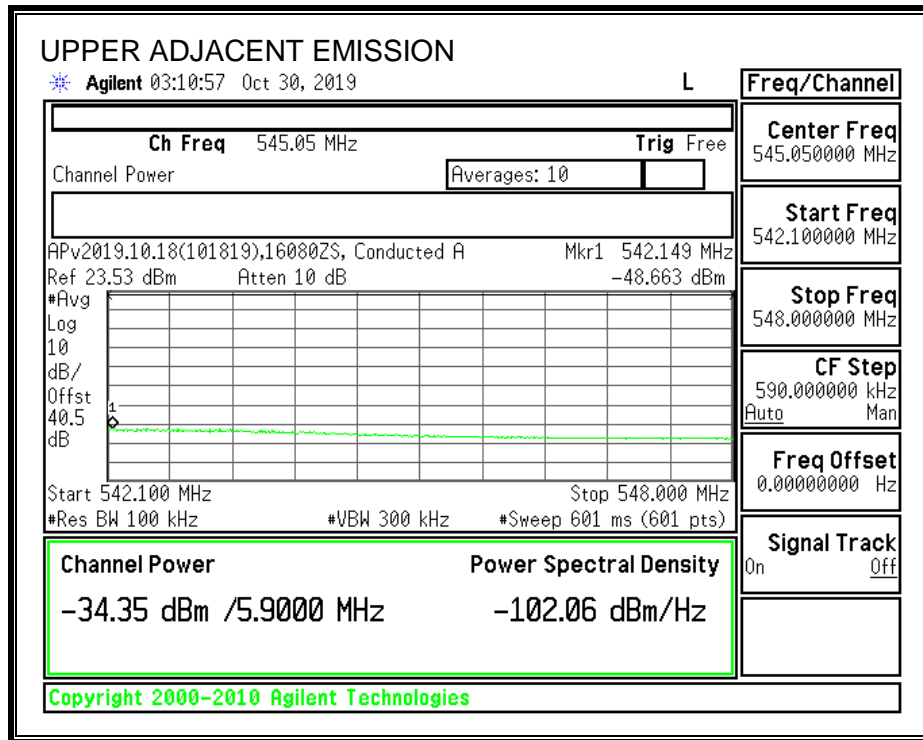
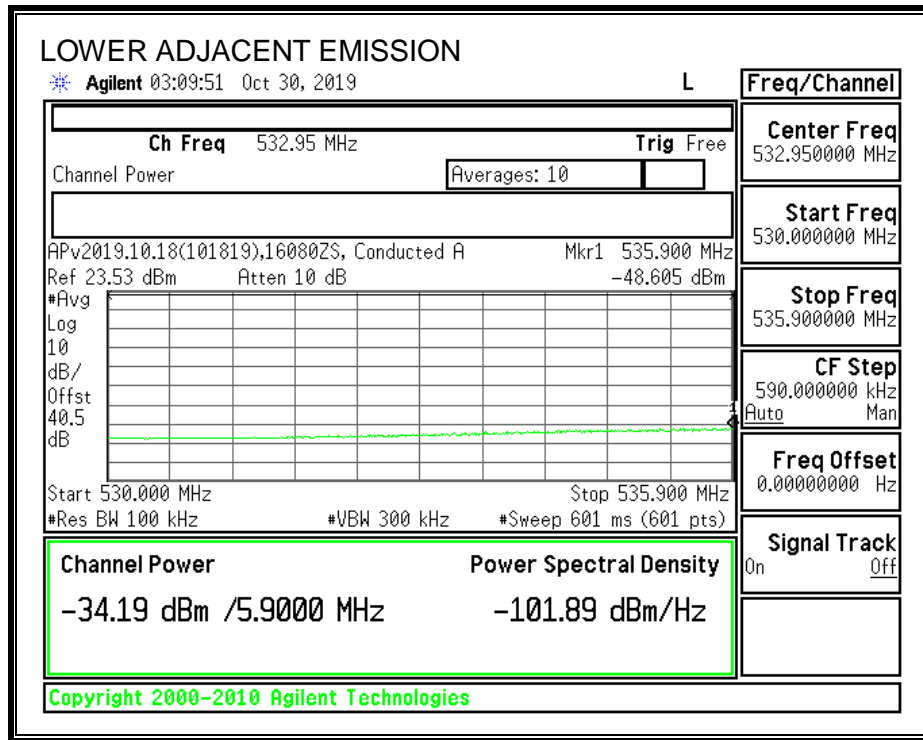

**HIGH CHANNEL**

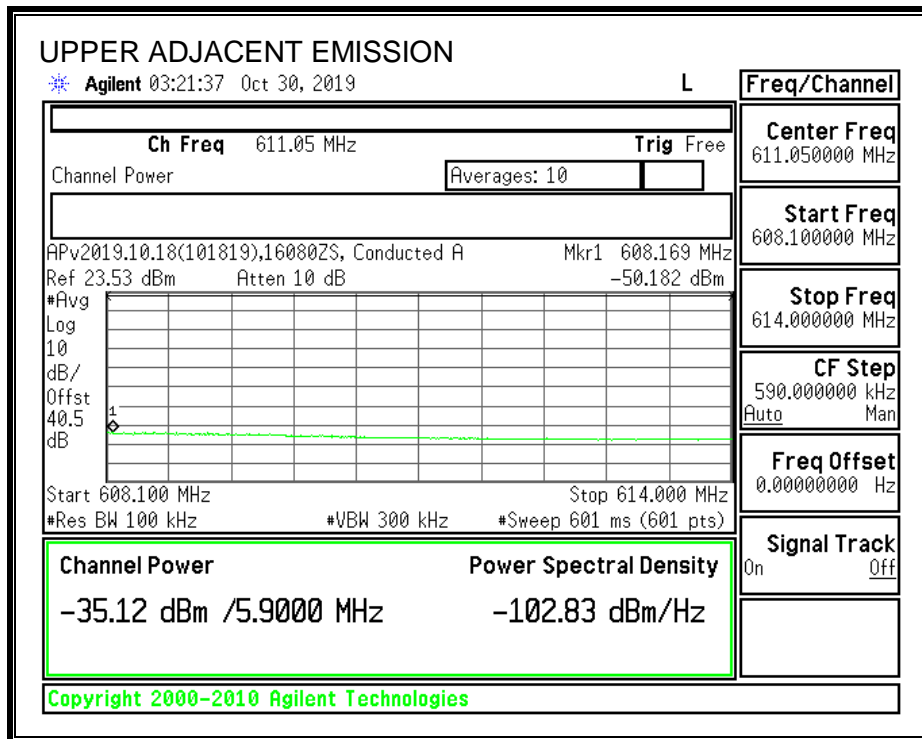
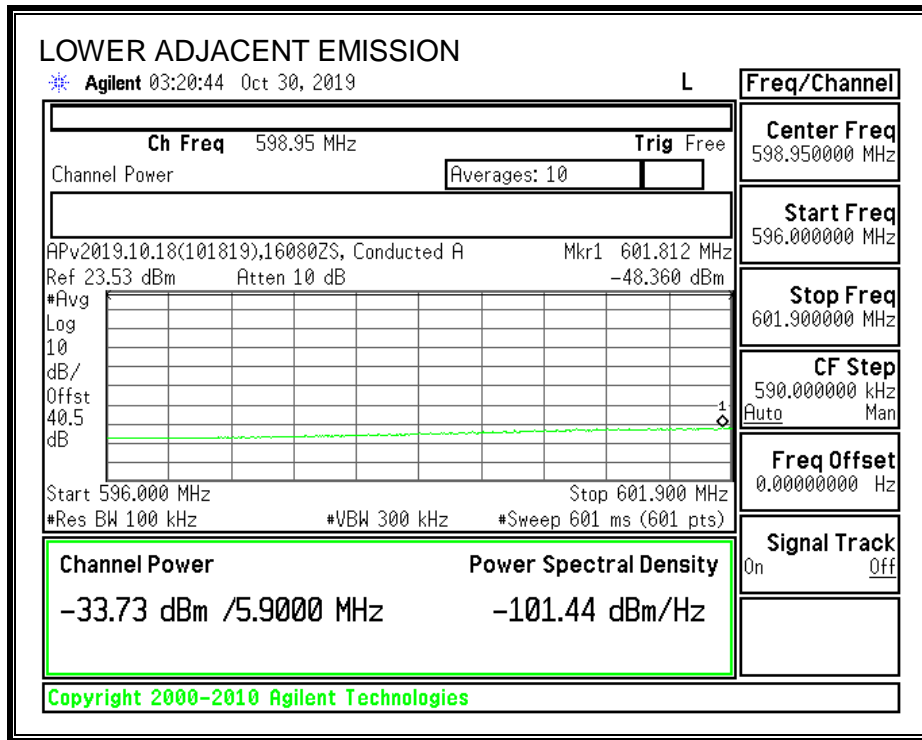

## 10. RADIATED EMISSIONS

### BEYOND ADJACENT CHANNEL EMISSION LIMITS

FCC §15.709 (d) (2) At frequencies beyond the six megahertz channel immediately adjacent to each white space channel or group of contiguous white space channels in which the white space device is operating the white space device shall meet the requirements of §15.209.

The DUT must comply with radiated emission limits for a Class B digital device, except that authorization as a Class A device may be considered with appropriate justification for non-residential use.

§15.209 (a) Except as provided elsewhere in this subpart, the emissions from an intentional radiator shall not exceed the field strength levels specified in the following table:

Frequency Range (MHz)	Field Strength Limit (uV/m) at 3m	Measurement distance (m)
0.009-0.490	2400/F(kHz)	300
0.490-1.705	24000/F(kHz)	30
1.705-30.0	30	30
30-88	100	3
88-216	150	3
216-960	200	3
Above 960	500	3

### TEST PROCEDURE

ANSI C63.10-2013.

The EUT is set to transmit in a continuous mode.

High-Q Cavity Notch filters are used to reduce the amplitude of the intentional transmitter and prevent overload of the system preamplifier.



## 10.1. TRANSMITTER BELOW 1GHZ

### 10.1.1.UHF BAND

#### BEYOND ADJACENT CHANNEL (LOW CHANNEL)

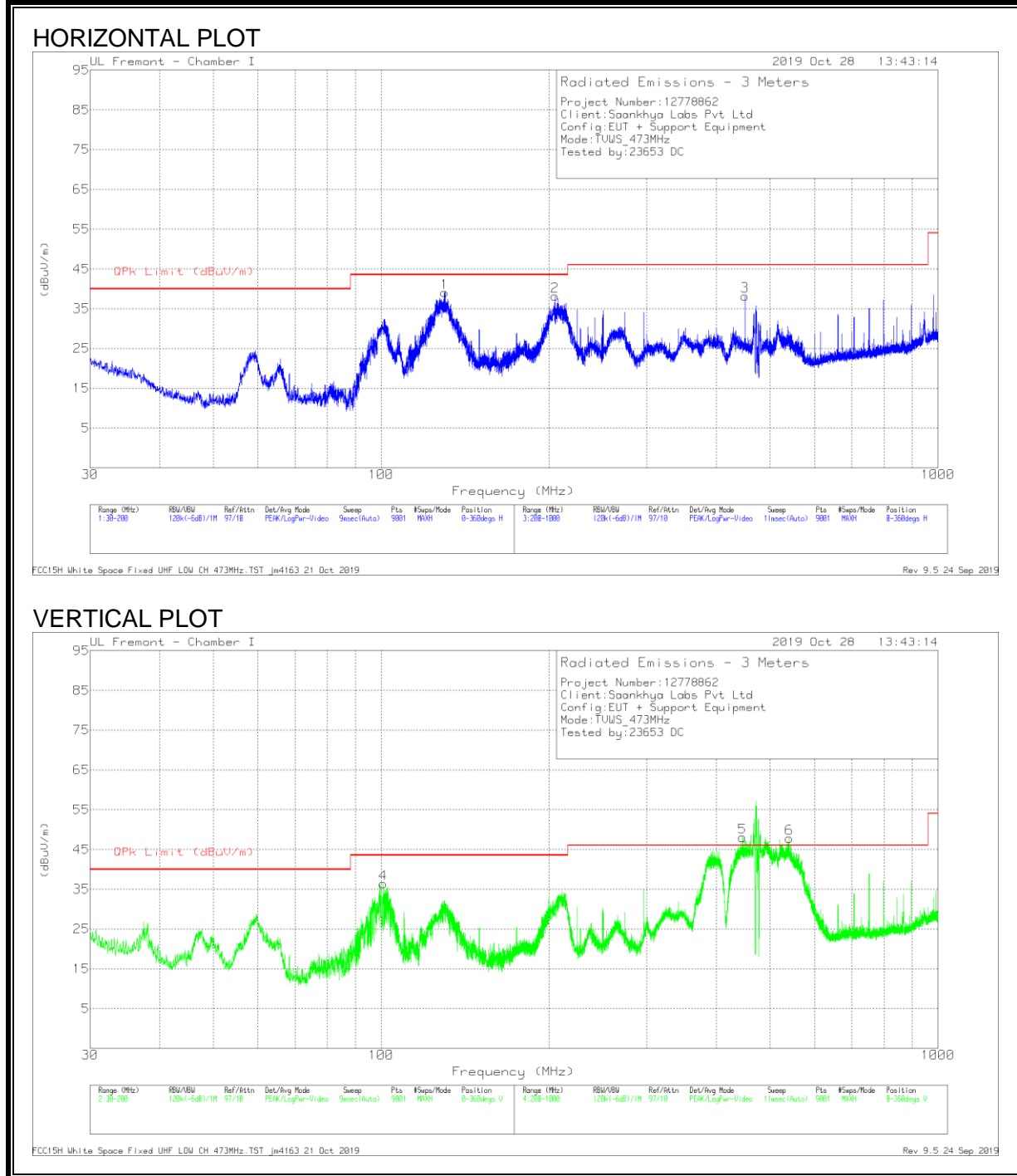

## LOW CHANNEL DATA

### Trace Markers

Marker	Frequency (MHz)	Meter Reading (dBuV)	Det	AF PRE0184971 (dB/m)	Amp Cbl (dB)	Filtr (dB)	Corrected Reading (dBuV/m)	QPk Limit (dBuV/m)	Margin (dB)	Azimuth (Degs)	Height (cm)	Polarity
1	130.0361	50	Pk	19.5	-30.6	.1	39	43.5	-4.5	0-360	199	H
4	100.8904	50.92	Pk	16.3	-30.9	.1	36.42	43.5	-7.08	0-360	102	V
2	205.1556	51.55	Pk	16.8	-30.3	.1	38.15	43.5	-5.35	0-360	102	H
3	449.9559	44.83	Pk	22.7	-29.4	.1	38.23	46	-7.77	0-360	102	H
5	445.4225	54.81	Pk	22.6	-29.5	.1	48.01	-	-	0-360	202	V
6	540.5338	53.13	Pk	23.9	-29.3	.1	47.83	-	-	0-360	102	V

Pk - Peak detector

### Radiated Emissions

Marker	Frequency (MHz)	Meter Reading (dBuV)	Det	AF PRE0184971 (dB/m)	Amp Cbl (dB)	Filtr (dB)	Corrected Reading (dBuV/m)	QPk Limit (dBuV/m)	Margin (dB)	Azimuth (Degs)	Height (cm)	Polarity
1	129.9662	45.41	Qp	19.5	-30.6	.1	34.41	43.5	-9.09	182	230	H
4	100.5567	45.66	Qp	16.2	-30.9	.1	31.06	43.5	-12.44	208	103	V
2	205.1926	50.61	Qp	16.7	-30.3	.1	37.11	43.5	-6.39	6	103	H
3	449.9959	40.61	Qp	22.7	-29.4	.1	34.01	46	-11.99	207	102	H
5	444.949	51.99	Qp	22.6	-29.5	.1	45.19	46	-.81	105	164	V
6	540.5228	48.05	Qp	23.9	-29.3	.1	42.75	46	-3.25	116	108	V

Qp - Quasi-Peak detector

**BEYOND ADJACENT CHANNEL (MID CHANNEL)**

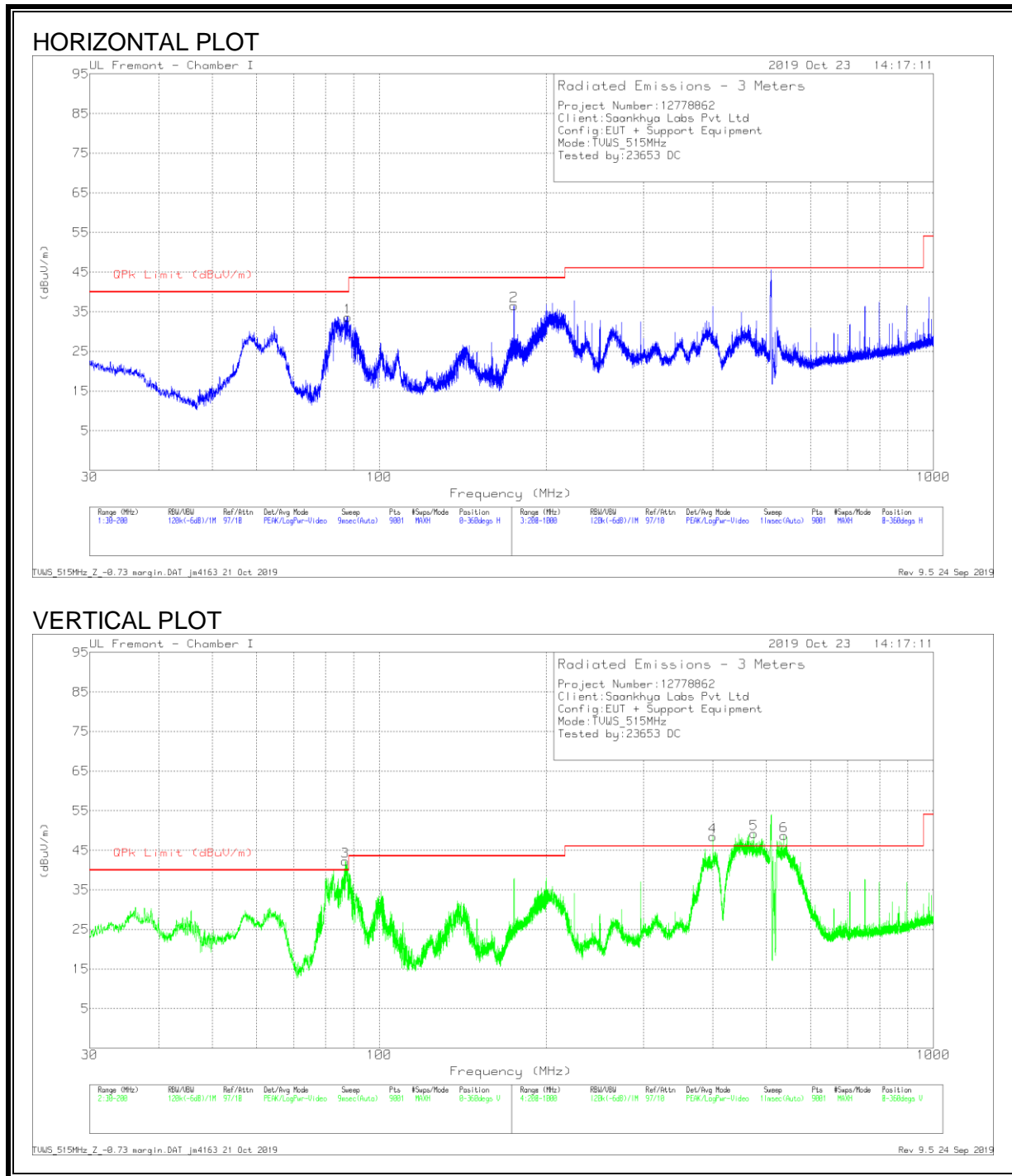

## MID CHANNEL DATA

### Trace Markers

Marker	Frequency (MHz)	Meter Reading (dBuV)	Det	AF PRE0184971 (dB/m)	Amp Cbl (dB)	Filtr (dB)	Corrected Reading (dBuV/m)	QPk Limit (dBuV/m)	Margin (dB)	Azimuth (Degs)	Height (cm)	Polarity
1	87.687	51.14	Pk	13.3	-31	.1	33.54	40	-6.46	0-360	199	H
2	174.992	49.68	Pk	17.2	-30.4	.1	36.58	43.5	-6.92	0-360	102	H
3	86.8748	59.86	Pk	13.3	-31	.1	42.26	-	-	0-360	102	V
4	399.9114	56.44	Pk	21.6	-29.7	.1	48.44	-	-	0-360	300	V
5	473.867	55.16	Pk	23.4	-29.5	.1	49.16	-	-	0-360	300	V
6	537.4226	54.05	Pk	23.9	-29.3	.1	48.75	-	-	0-360	199	V

Pk - Peak detector

### Radiated Emissions

Marker	Frequency (MHz)	Meter Reading (dBuV)	Det	AF PRE0184971 (dB/m)	Amp Cbl (dB)	Filtr (dB)	Corrected Reading (dBuV/m)	QPk Limit (dBuV/m)	Margin (dB)	Azimuth (Degs)	Height (cm)	Polarity
3	87.0386	53.61	Qp	13.3	-31	.1	36.01	40	-3.99	297	148	V
4	399.9993	53.27	Qp	21.6	-29.7	.1	45.27	46	-7.3	107	167	V
5	473.5363	51.26	Qp	23.4	-29.5	.1	45.26	46	-7.4	112	153	V
6	537.5125	48.92	Qp	23.9	-29.3	.1	43.62	46	-2.38	108	123	V

Qp - Quasi-Peak detector

**BEYOND ADJACENT CHANNEL (HIGH CHANNEL)**

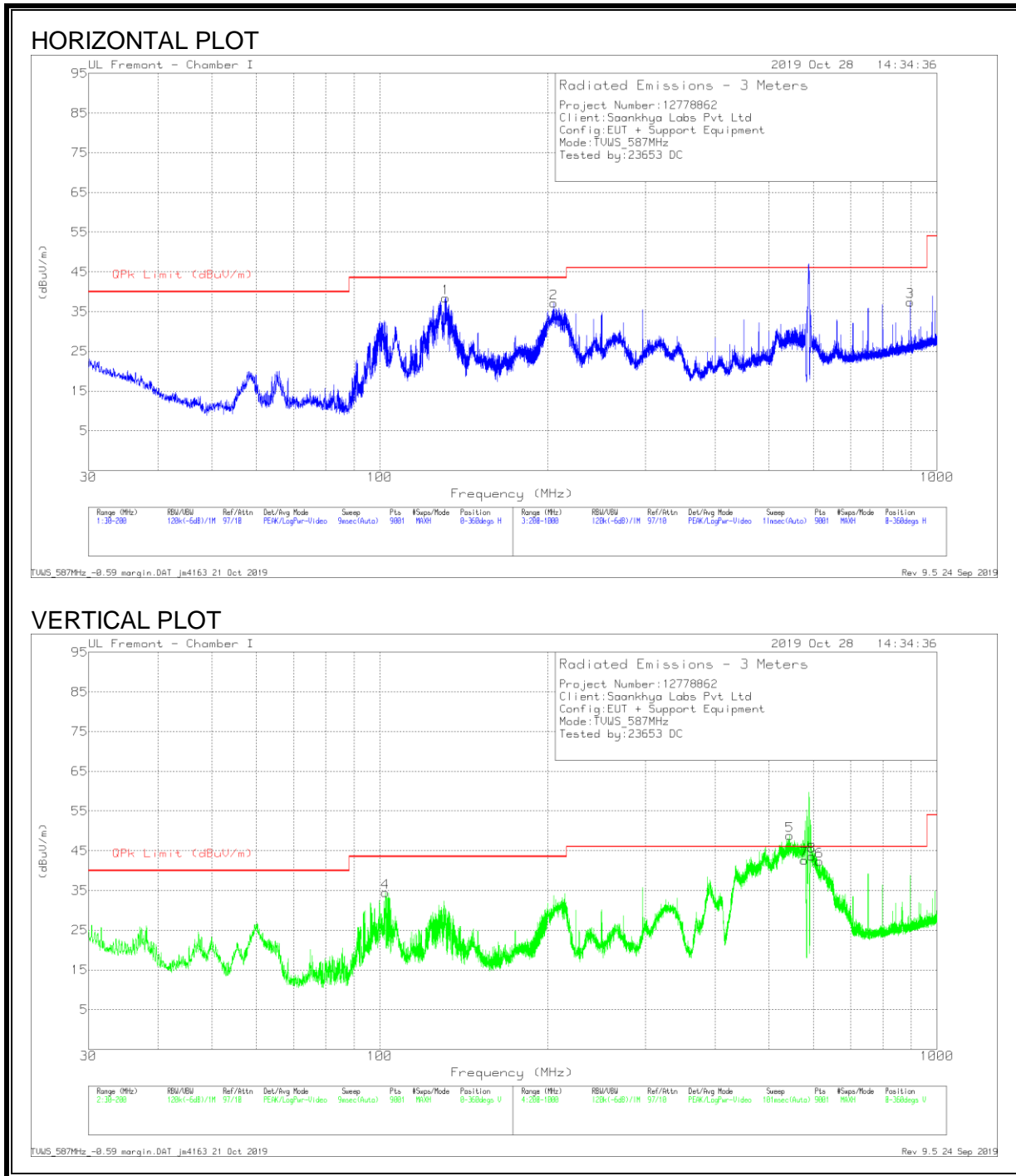

## HIGH CHANNEL DATA

### Trace Markers

Marker	Frequency (MHz)	Meter Reading (dBuV)	Det	AF PRE0184971 (dB/m)	Amp Cbl (dB)	Filtr (dB)	Corrected Reading (dBuV/m)	QPk Limit (dBuV/m)	Margin (dB)	Azimuth (Degs)	Height (cm)	Polarity
1	131.2639	49.47	Pk	19.5	-30.7	.2	38.47	43.5	-5.03	0-360	199	H
4	102.3449	48.26	Pk	16.7	-30.7	.2	34.46	43.5	-9.04	0-360	101	V
2	205.1556	50.41	Pk	16.8	-30.3	.2	37.11	43.5	-6.39	0-360	101	H
3	896.0009	37.07	Pk	27.9	-27.7	.2	37.47	46	-8.53	0-360	101	H
5	544.0004	53.94	Pk	24	-29.3	.2	48.84	-	-	0-360	201	V
6	615.8227	46.52	Pk	24.9	-29.3	.2	42.32	46	-3.68	0-360	201	V
7	577.956	47.09	Pk	24.5	-29.2	.2	42.59	46	-3.41	0-360	102	V
8	596.0005	48.29	Pk	24.2	-29.1	.2	43.59	46	-2.41	0-360	102	V

PK - Peak detector

### Radiated Emissions

Frequency (MHz)	Meter Reading (dBuV)	Det	AF PRE0184971 (dB/m)	Amp Cbl (dB)	Filtr (dB)	Corrected Reading (dBuV/m)	QPk Limit (dBuV/m)	Margin (dB)	Azimuth (Degs)	Height (cm)	Polarity
131.2659	41.08	Qp	19.5	-30.7	.2	30.08	43.5	-13.42	185	207	H
544.0603	50.51	Qp	24	-29.3	.2	45.41	46	-.59	113	118	V
615.6059	45.45	Qp	24.9	-29.2	.2	41.35	46	-4.65	109	154	V
578.1203	48.51	Qp	24.5	-29.2	.2	44.01	46	-1.99	22	171	V
596.1468	47.01	Qp	24.2	-29.1	.2	42.31	46	-3.69	25	158	V

Qp - Quasi-Peak detector

## 10.2. TRANSMITTER ABOVE 1GHz

### 10.2.1. HARMONICS AND SPURIOUS EMISSIONS IN THE UHF BAND

#### LOW CHANNEL

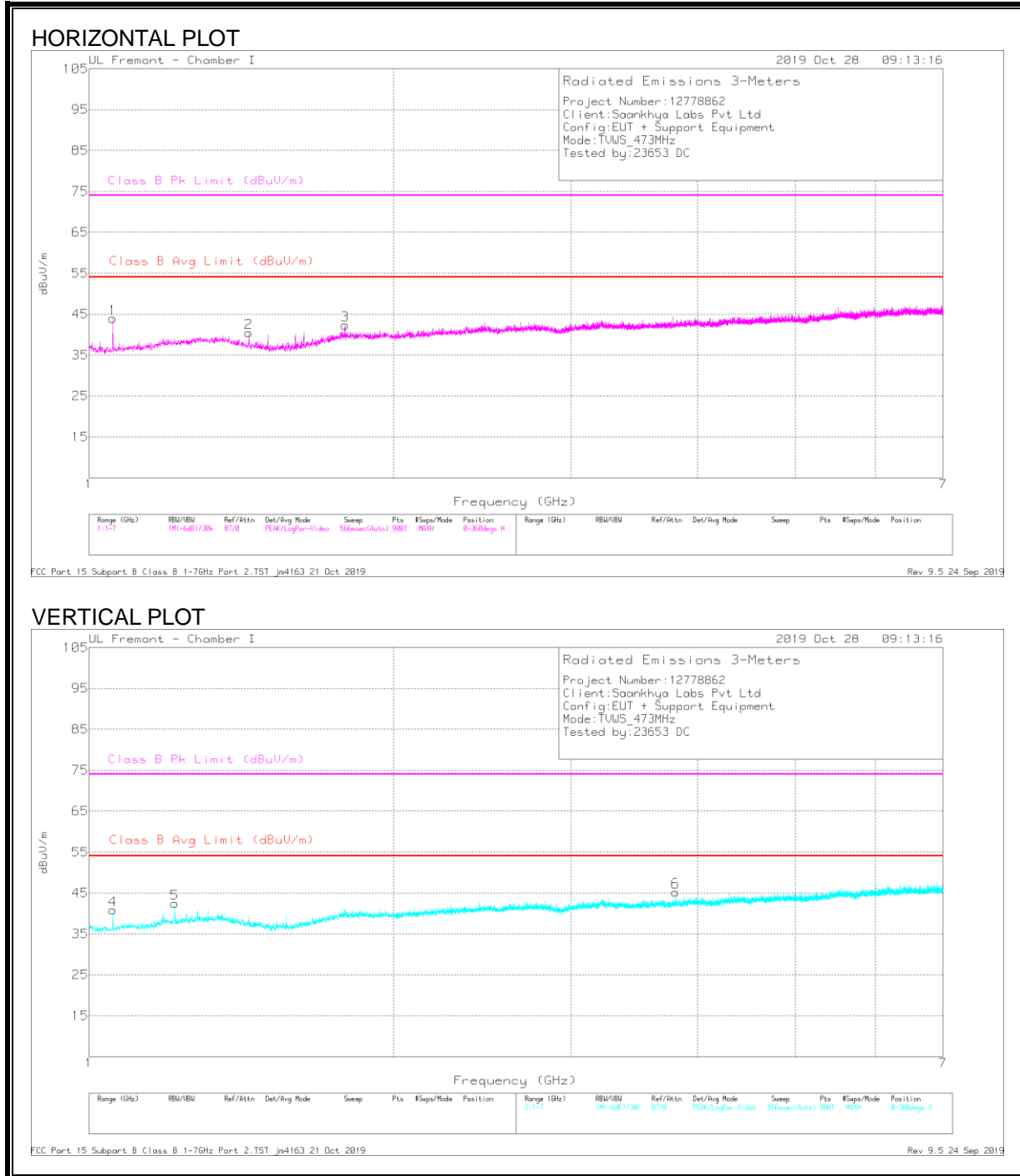

## LOW CHANNEL DATA

### Radiated Emissions

Marker	Frequency (GHz)	Meter Reading (dBuV)	Det	AF T862 (dB/m)	Amp/Cb/FI tr/Pad (dB)	Corrected Reading dBuV/m	Class B Avg Limit (dBuV/m)	Av Margin (dB)	Class B Pk Limit (dBuV/m)	PK Margin (dB)	Azimuth (Degs)	Height (cm)	Polarity
1	1.05608	45.03	Pk	27	-22.1	49.93	-	-	74	-24.07	266	117	H
	1.05604	38.51	Av	27	-22.1	43.41	54	-10.59	-	-	266	117	H
2	1.44004	41.13	Pk	28.4	-21.5	48.03	-	-	74	-25.97	261	193	H
	1.43985	29.83	Av	28.4	-21.5	36.73	54	-17.27	-	-	261	193	H
3	1.79224	40.76	Pk	30.4	-20.1	51.06	-	-	74	-22.94	349	155	H
	1.79226	28.44	Av	30.4	-20.1	38.74	54	-15.26	-	-	349	155	H
4	1.0559	43.36	Pk	27	-22.1	48.26	-	-	74	-25.74	21	198	V
	1.05599	33.85	Av	27	-22.1	38.75	54	-15.25	-	-	21	198	V
5	1.21615	41.77	Pk	28.6	-20.7	49.67	-	-	74	-24.33	17	102	V
	1.21602	32.15	Av	28.6	-20.7	40.05	54	-13.95	-	-	17	102	V
6	3.80643	36.76	Pk	32.9	-17.6	52.06	-	-	74	-21.94	129	138	V
	3.80675	23.79	Av	32.9	-17.6	39.09	54	-14.91	-	-	129	138	V

Pk - Peak detector

Av - Average detection



**MID CHANNEL**

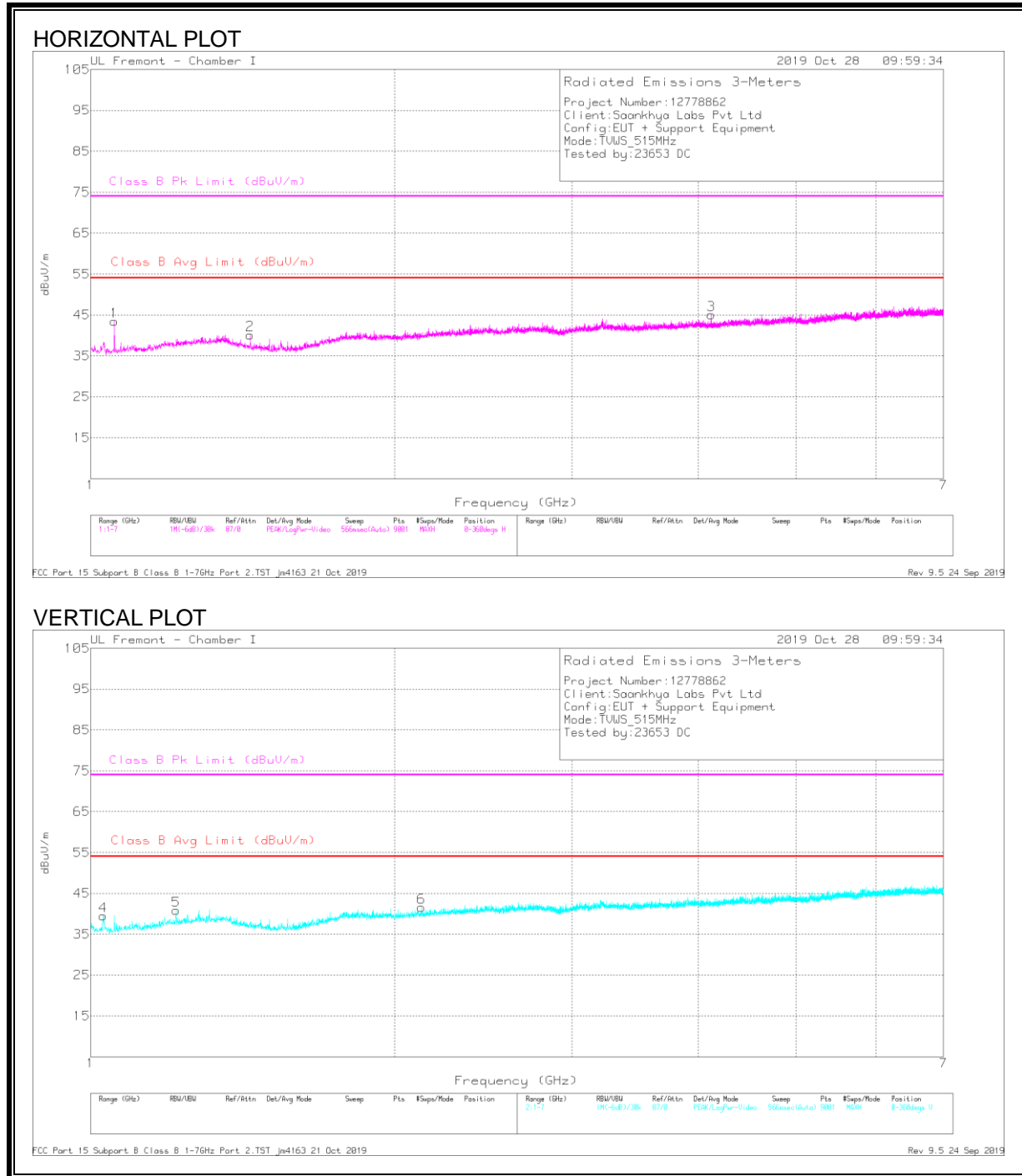

### MID CHANNEL DATA

#### Radiated Emissions

Marker	Frequency (GHz)	Meter Reading (dBuV)	Det	AF T862 (dB/m)	Amp/Cbl/FI tr/Pad (dB)	Corrected Reading dBuV/m	Class B Avg Limit (dBuV/m)	Av Margin (dB)	Class B PK Limit (dBuV/m)	PK Margin (dB)	Azimuth (Degs)	Height (cm)	Polarity
1	1.0559	44.97	Pk	27	-22.1	49.87	-	-	74	-24.13	265	108	H
	1.0561	37.23	Av	27	-22.1	42.13	54	-11.87	-	-	265	108	H
2	1.43988	41.48	Pk	28.4	-21.5	48.38	-	-	74	-25.62	256	201	H
	1.44017	29.54	Av	28.4	-21.6	36.34	54	-17.66	-	-	256	201	H
3	4.11992	38.33	Pk	33.3	-18.2	53.43	-	-	74	-20.57	65	101	H
	4.12028	26.07	Av	33.3	-18.2	41.17	54	-12.83	-	-	65	101	H
4	1.02941	48.86	Pk	27.3	-22.5	53.66	-	-	74	-20.34	341	296	V
	1.02937	33.73	Av	27.3	-22.5	38.53	54	-15.47	-	-	341	296	V
5	1.21609	41.95	Pk	28.6	-20.7	49.85	-	-	74	-24.15	18	102	V
	1.21576	30.31	Av	28.6	-20.7	38.21	54	-15.79	-	-	18	102	V
6	2.1256	39.36	Pk	31.2	-20.5	50.06	-	-	74	-23.94	326	197	V
	2.1259	25.87	Av	31.2	-20.5	36.57	54	-17.43	-	-	326	197	V

Pk - Peak detector  
 Av - Average detection

**HIGH CHANNEL**

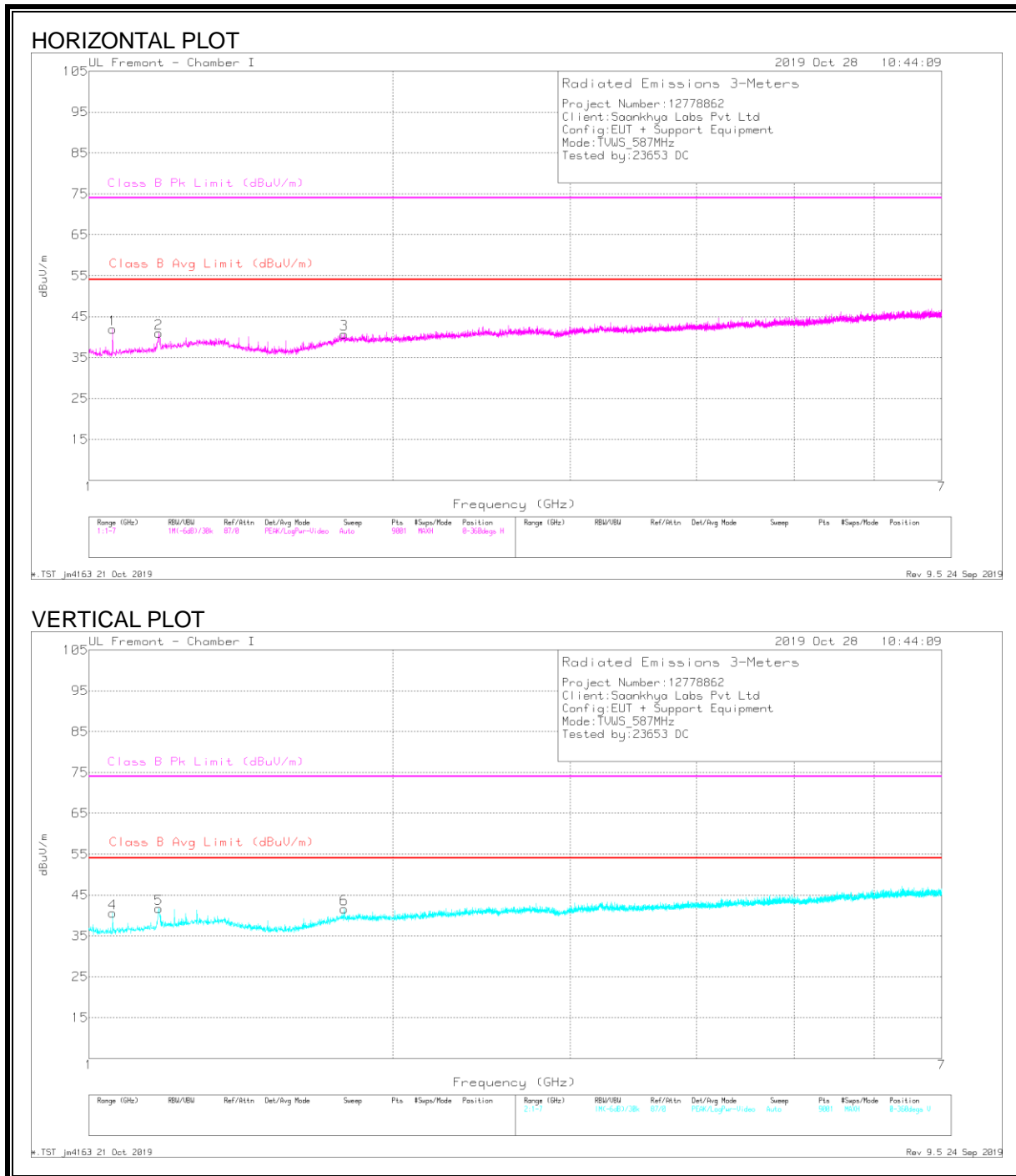

**HIGH CHANNEL DATA**

**Radiated Emissions**

Marker	Frequency (GHz)	Meter Reading (dBuV)	Det	AF T862 (dB/m)	Amp/Cbl/FI tr/Pad (dB)	Corrected Reading dBuV/m	Class B Avg Limit (dBuV/m)	Av Margin (dB)	Class B Pk Limit (dBuV/m)	PK Margin (dB)	Azimuth (Degs)	Height (cm)	Polarity
1	1.05605	45.3	Pk	27	-22.1	50.2	-	-	74	-23.8	301	113	H
	1.05607	37.46	Av	27	-22.1	42.36	54	-11.64	-	-	301	113	H
2	1.17333	48.89	Pk	27.7	-20.9	55.69	-	-	74	-18.31	264	163	H
	1.17325	32.51	Av	27.7	-20.9	39.31	54	-14.69	-	-	264	163	H
3	1.792	40.56	Pk	30.4	-20.1	50.86	-	-	74	-23.14	44	189	H
	1.79204	30.2	Av	30.4	-20.1	40.5	54	-13.5	-	-	44	189	H
4	1.05615	42.72	Pk	27	-22.1	47.62	-	-	74	-26.38	26	166	V
	1.05611	32.36	Av	27	-22.1	37.26	54	-16.74	-	-	26	166	V
5	1.17341	49.23	Pk	27.7	-20.9	56.03	-	-	74	-17.97	24	230	V
	1.17328	32.59	Av	27.7	-20.9	39.39	54	-14.61	-	-	24	230	V
6	1.17328	32.61	Av	27.7	-20.9	39.41	54	-14.59	-	-	24	230	V
	1.7921	39.83	Pk	30.4	-20.1	50.13	-	-	74	-23.87	186	112	V
	1.79213	27.3	Av	30.4	-20.1	37.6	54	-16.4	-	-	186	112	V

Pk - Peak detector  
 Av - Average detection

## 11. AC MAINS LINE CONDUCTED EMISSIONS

### LIMITS

FCC §15.207 (a)

Frequency range (MHz)	Limits (dBµV)	
	Quasi-peak	Average
0.15 to 0.5	66 to 56*	56 to 46*
0.5 to 5	56	46
5 to 30	60	50

\*Decreases with the Logarithm of the frequency

### TEST PROCEDURE

ANSI C63.4-2009.

Line conducted data is recorded for both NEUTRAL and HOT lines.

## 11.1. UHF MODE

### 11.1.1.LINE 1 TX RESULTS

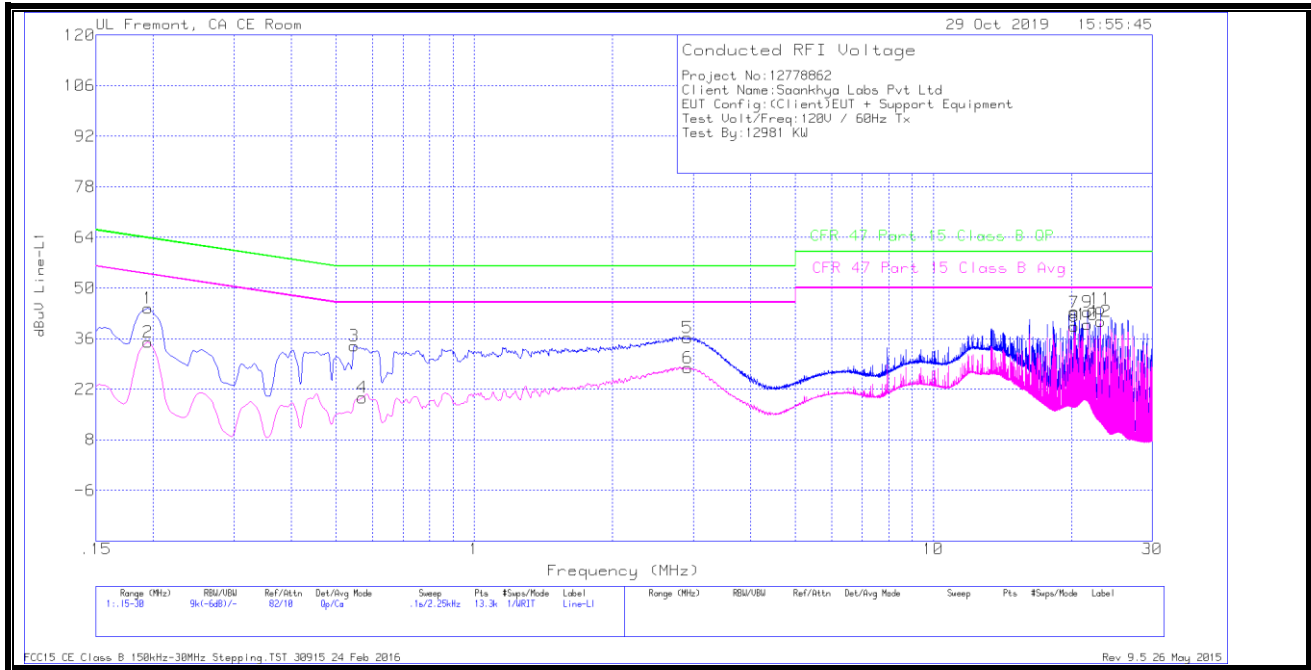

## DATA

Range 1: Line-L1 .15 - 30MHz											
Marker	Frequency (MHz)	Meter Reading (dBuV)	Det	LISN L1	LC Cables C1&C3	Limiter (dB)	Corrected Reading dBuV	CFR 47 Part 15 Class B QP	QP Margin (dB)	CFR 47 Part 15 Class B Avg	Av(CISPR) Margin (dB)
1	.195	34.3	Qp	0	0	10.1	44.4	63.82	-19.42	-	-
2	.195	24.88	Ca	0	0	10.1	34.98	-	-	53.82	-18.84
3	.54825	23.93	Qp	0	0	10.1	34.03	56	-21.97	-	-
4	.57075	9.57	Ca	0	0	10.1	19.67	-	-	46	-26.33
5	2.91525	26.01	Qp	0	.1	10.1	36.21	56	-19.79	-	-
6	2.922	17.66	Ca	0	.1	10.1	27.86	-	-	46	-18.14
7	20.25825	32.53	Qp	.1	.3	10.3	43.23	60	-16.77	-	-
8	20.25825	28.73	Ca	.1	.3	10.3	39.43	-	-	50	-10.57
9	21.66225	32.57	Qp	.1	.3	10.4	43.37	60	-16.63	-	-
10	21.66225	29.07	Ca	.1	.3	10.4	39.87	-	-	50	-10.13
11	23.12925	33.4	Qp	.1	.3	10.4	44.2	60	-15.8	-	-
12	23.12925	29.97	Ca	.1	.3	10.4	40.77	-	-	50	-9.23

Qp - Quasi-Peak detector  
 Ca - CISPR average detection

### 11.1.2.LINE 2 TX RESULTS

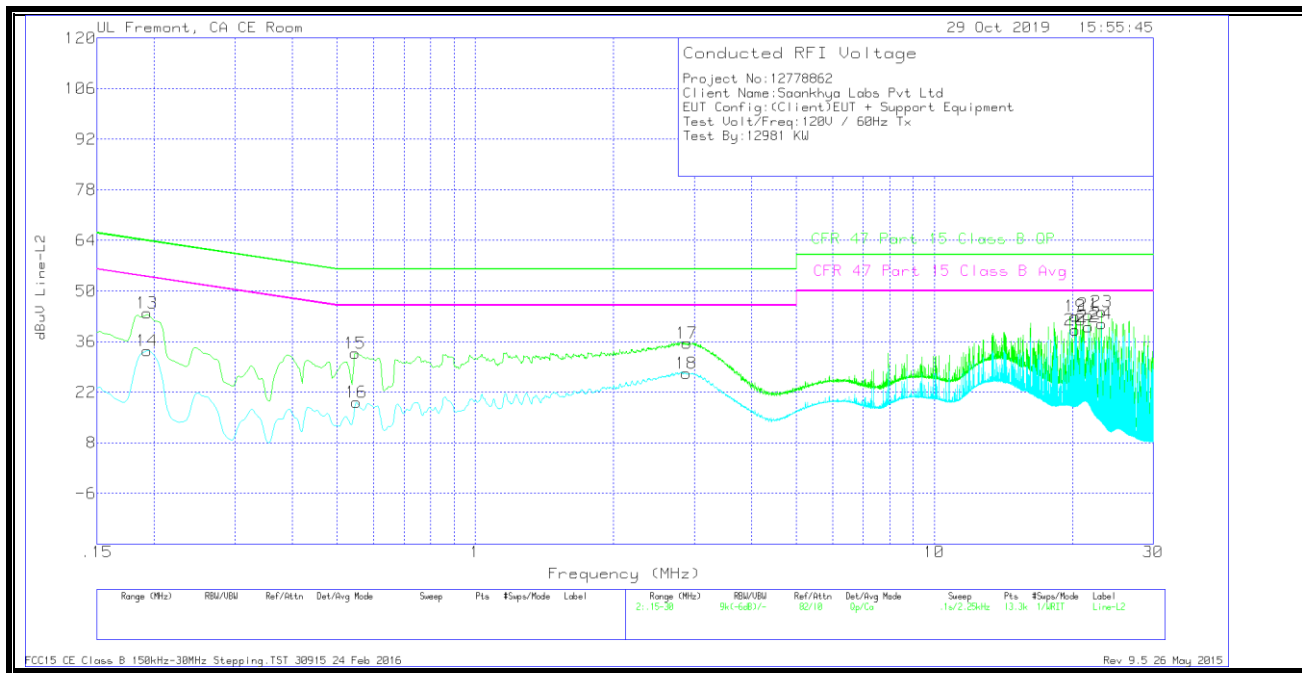

### DATA

Range 2: Line-L2 .15 - 30MHz											
Marker	Frequency (MHz)	Meter Reading (dBuV)	Det	LISN L2	LC Cables C2&C3	Limiter (dB)	Corrected Reading dBuV	CFR 47 Part 15 Class B QP	QP Margin (dB)	CFR 47 Part 15 Class B Avg	Av(CISPR) Margin (dB)
13	.19275	43.5	Qp	0	0	10.1	53.6	63.92	-10.32	-	-
14	.19275	23.33	Ca	0	0	10.1	33.43	-	-	53.92	-20.49
15	.54825	22.71	Qp	0	0	10.1	32.81	56	-23.19	-	-
16	.5505	9.07	Ca	0	0	10.1	19.17	-	-	46	-26.83
17	2.89275	25.38	Qp	0	.1	10.1	35.58	56	-20.42	-	-
18	2.8815	17	Ca	0	.1	10.1	27.2	-	-	46	-18.8
19	20.25825	32.31	Qp	.1	.3	10.3	43.01	60	-16.99	-	-
20	20.25825	28.59	Ca	.1	.3	10.3	39.29	-	-	50	-10.71
21	21.66225	32.68	Qp	.1	.3	10.4	43.48	60	-16.52	-	-
22	21.66225	29.23	Ca	.1	.3	10.4	40.03	-	-	50	-9.97
23	23.12925	33.54	Qp	.1	.3	10.4	44.34	60	-15.66	-	-
24	23.12925	30.2	Ca	.1	.3	10.4	41	-	-	50	-9

Qp - Quasi-Peak detector  
 Ca - CISPR average detection

## 12. FIXED CLIENT DATABASE CERTIFICATION TESTS

The test requirements were done on the client connected to base which is connected to the DB through TVWS application on host PC . The TVWS application acts as a proxy relaying messages from the base and client to the WSDB server.

### 12.1. Fixed WSD Registration -Client

#### CLAUSES

- §15.713(g)(3)

#### REQUIREMENT

- The Fixed WSD must provide the required information to the database and obtain a successful registration.
- The management software must be able to collect the data listed below. Confirm that the EUT will not operate unless a successful registration notification is received from the database.
  - i. FCC ID
  - ii. Serial Number
  - iii. Location Coordinates
  - iv. Location uncertainty with 95% accuracy (covered by section 3.8 in this report)
  - v. Antenna Height AGL (must not be > 30 m)
  - vi. Contact information (Device owner and device contact)
- For a fixed WSD without a direct connection to the internet, confirm that registration through a registered fixed device takes place only on a channel available to that registered device.
- PRE-REGISTRATION PROCESS
- Both the Base and Client Station are provisioned using TVWS application via the Internet at the operator facility. During the course of registration a common available channel between the base and the client which is selected as the initial transmitting channel by the base. This channel will be the initial “listening” channel for the Client Station



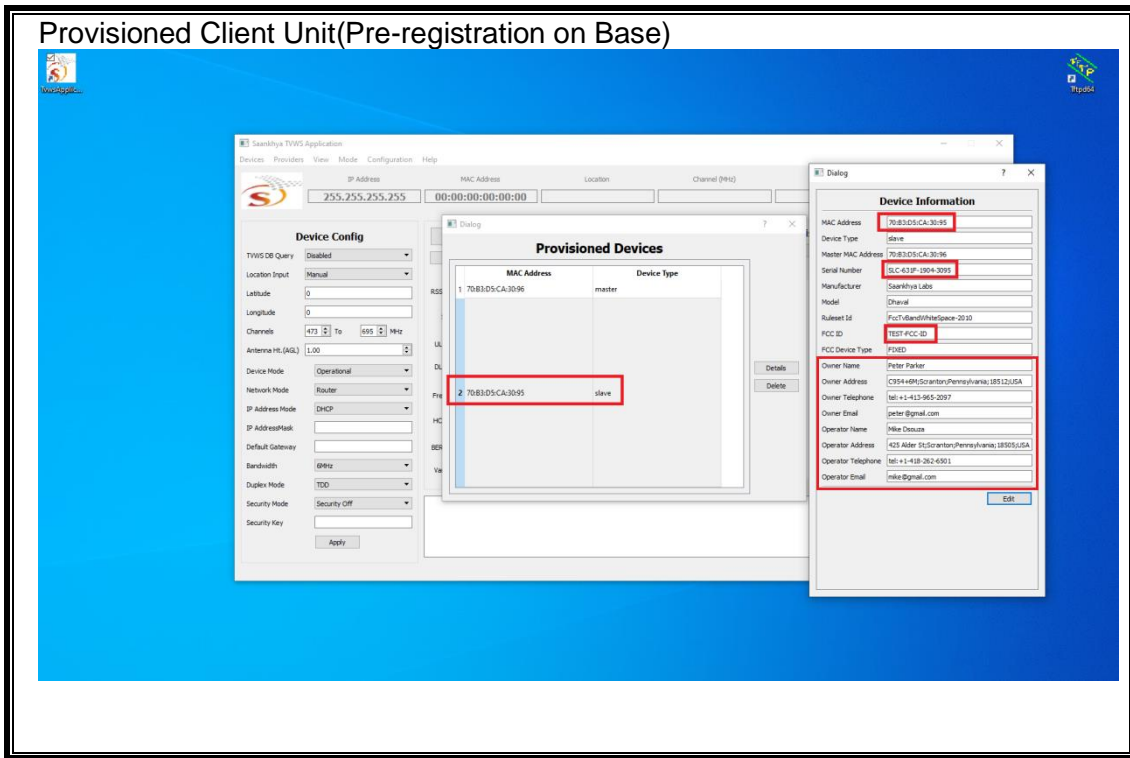

### 12.1.1.SUCCESSFUL REGISTRATION

#### TEST PROCEDURE

- Configure the base EUT with correct registration information for both the base and the client units:
  - The FCC ID and serial number are permanently programmed to the device and cannot be modified.
  - Known acceptable geographic coordinates, antenna height AGL and contact information were entered into the EUTs using TVWS Application on both sides.
- The base EUT automatically contacts the TVWS Database to perform device registration.
- Upon successful registration, the base EUT automatically contacts the TVWS Database to retrieve device channel list
- Selects a channel from the channel list returned from the TVWS Database and start normal radio operation on the selected channel.
- The client connects to base on the “listening” channel and sends the location co-ordinates and antenna height
- Base retrieves the list of channels available at client location using this information and the information provided during provisioning and allows client to transmit on “listening” channel if it is present in this list
- Verify client output signal on the selected channel on the spectrum analyzer.

#### RESULTS

The client EUT successfully registered when correct registration information was submitted to the TVWS Database. The EUT transmission was observed on the spectrum analyzer on the selected TV channel from the returned channel list from the TVWS Database.

Test Results			
Pass	Fail	Tested By	Test Date
<input checked="" type="checkbox"/>	<input type="checkbox"/>	16080ZS	10/23/19

### Successful Device Registration with Database

The client doesn't have option to select the channel from database – it has to operate on the channel selected by the base

### Channel selection from Database

Client registered on ch. 20 selected by base station

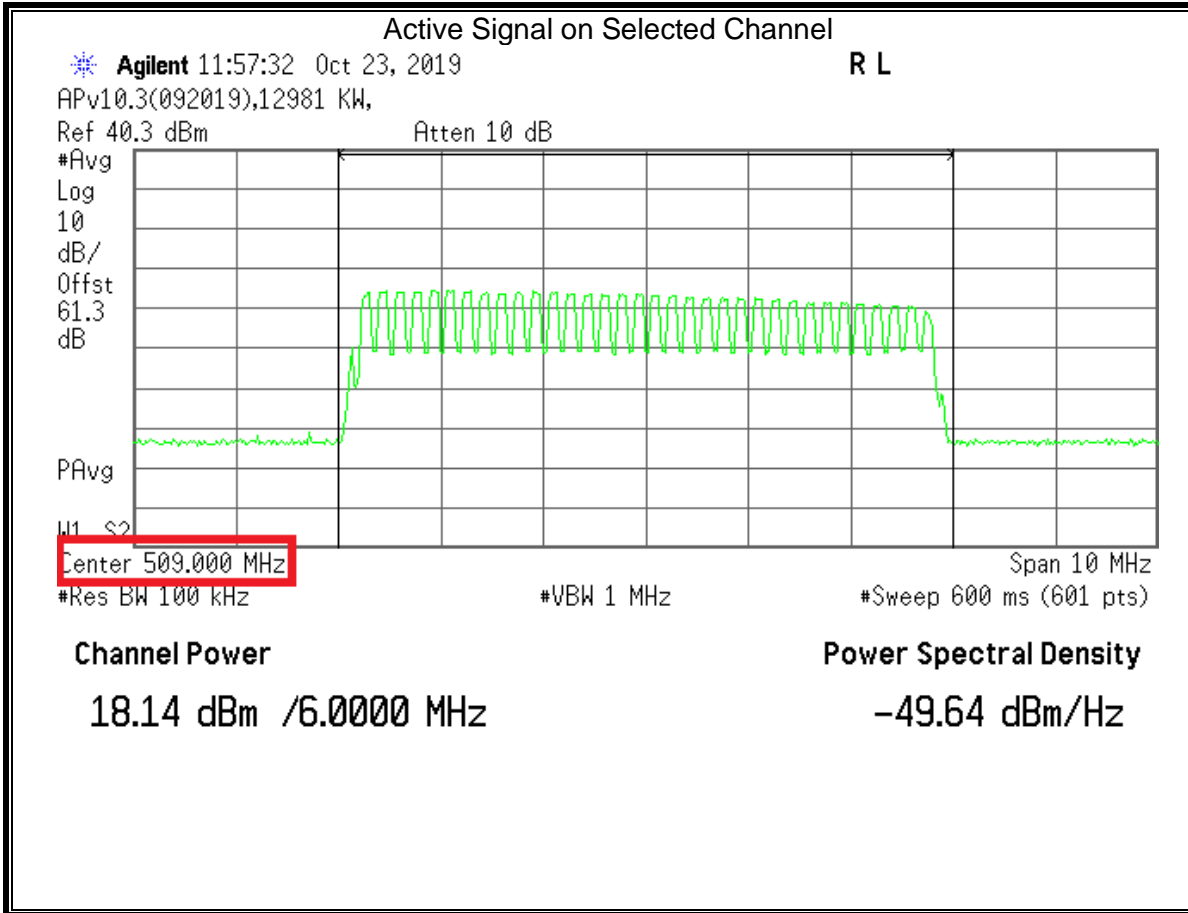



### Failed Registration Client side

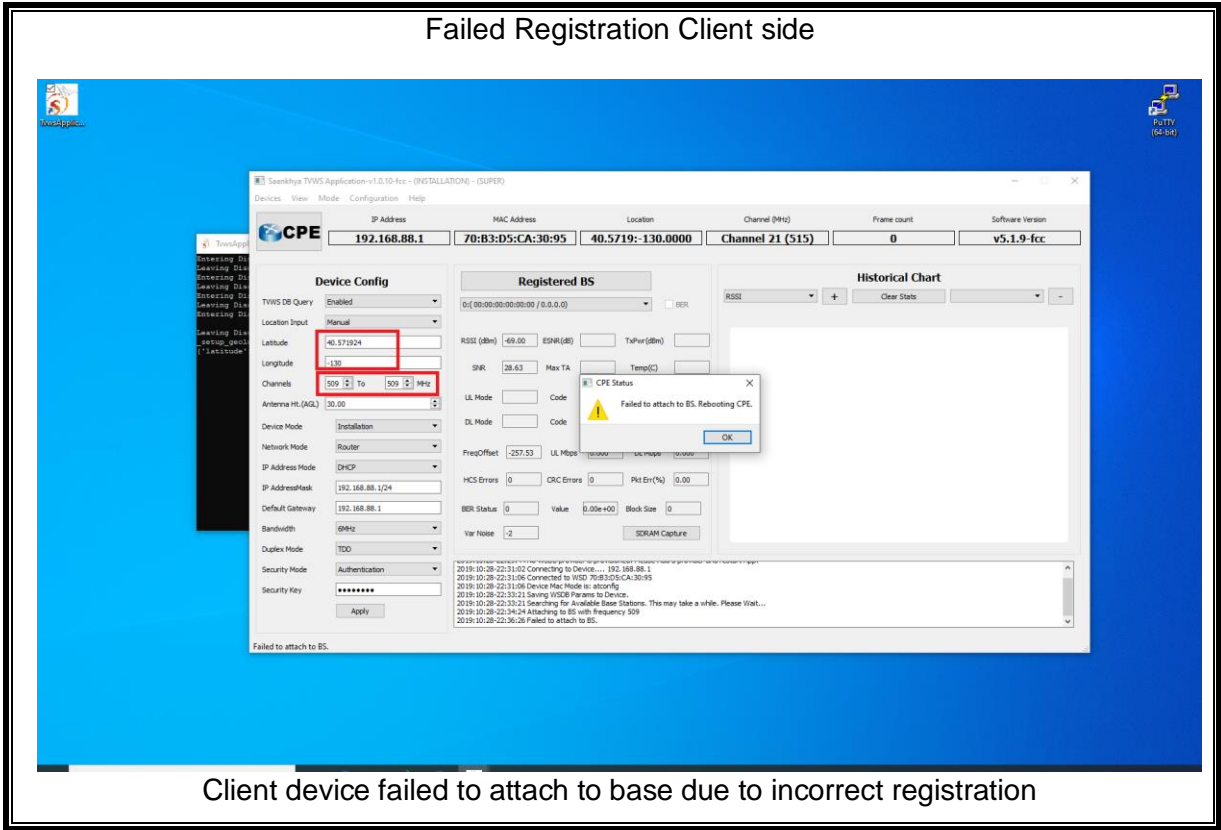

Client device failed to attach to base due to incorrect registration

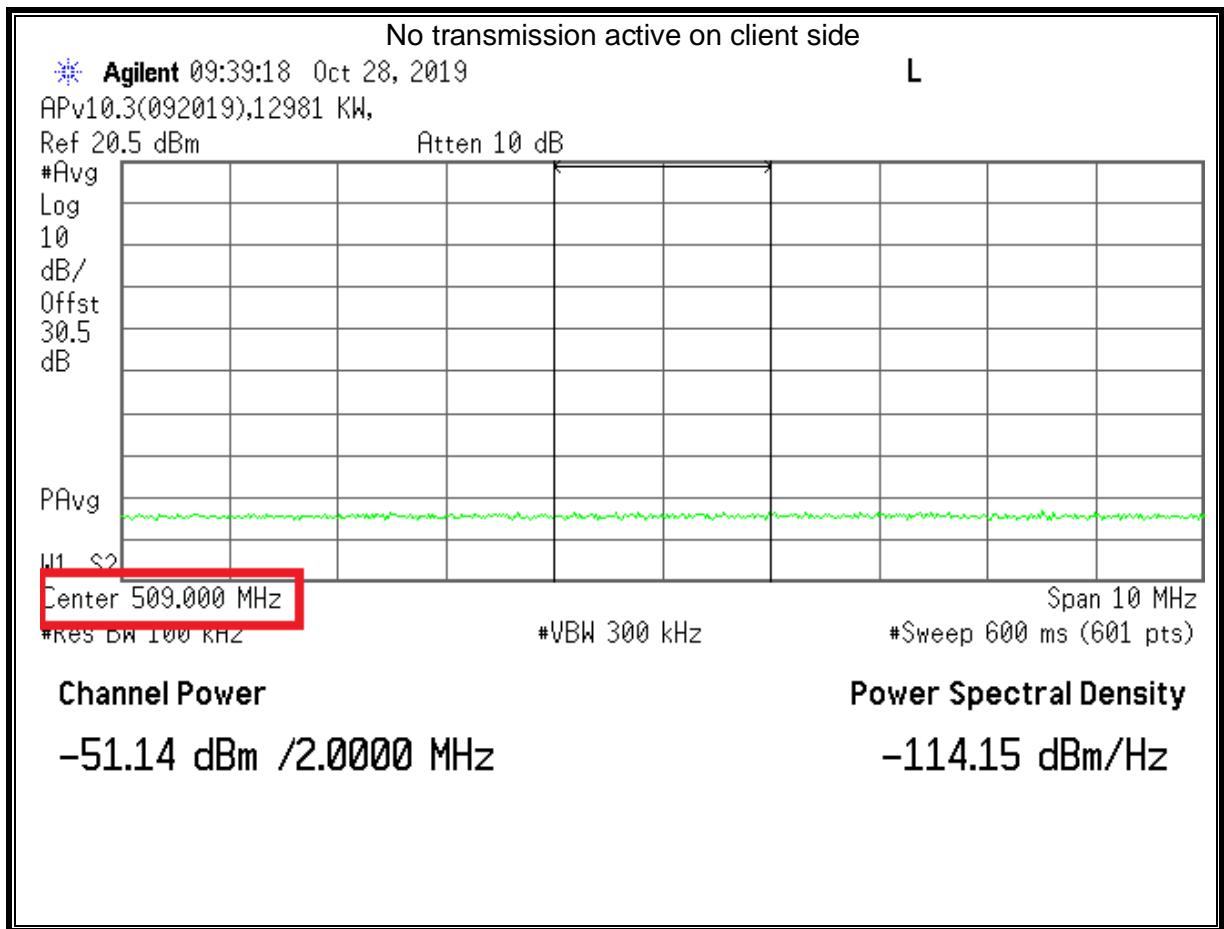

### 12.1.3.FAILED REGISTRATION – ANTENNA HEIGHT AGL

#### TEST PROCEDURE

- Configure the EUT with antenna height Above Ground Level (AGL) > 30 meters.
- Observe the base registration failure indicated by the database message.

#### RESULTS

The client EUT could not be configured using TVWS Application with antenna height >30m AGL hence registration with antenna height >30m AGL was not allowed

Test Results			
Pass	Fail	Tested By	Test Date
<input checked="" type="checkbox"/>	<input type="checkbox"/>	16080ZS	10/23/19

Antenna AGL > 30m

The screenshot shows the TVWS Application interface with the following configuration details:

- Device Config:**
  - TVWS DB Query: Enabled
  - Location Input: Manual
  - Latitude: 41.40801
  - Longitude: -75.643303
  - Channels: 473 To 605 MHz
  - Antenna Ht (AGL): **30m** (highlighted in red)
  - Device Mode: Installation
  - Network Mode: Router
  - IP Address Mode: DHCP
  - IP Address Mask: 192.168.88.1/24
  - Default Gateway: 192.168.88.1
  - Bandwidth: 6MHz
  - Duplex Mode: TDD
  - Security Mode: Authentication
  - Security Key: \*\*\*\*\*
- Registered BS:**
  - IP Address: 192.168.88.1
  - MAC Address: 70:B3:D5:CA:30:95
  - Location: 0.0000:0.0000
  - Channel (MHz): Channel 27 (551)
  - Frame count: 0
  - Software Version: v5.1.9-fcc
- Historical Chart:** RSSI, Clear State

Log messages at the bottom of the interface:

```

2019-10-23-23:41:13 No WSDM provider is provisioned. Please Add a provider and restart App.
2019-10-23-23:41:24 Connecting to Device... 192.168.88.1
2019-10-23-23:41:28 Connected to WSD: 70:B3:D5:CA:30:95
2019-10-23-23:41:28 Device Mac Mode is: atcnfig
    
```

- EUT registration cannot happen without provisioning through the TVWS application (refer Theory of Operations)
- TVWS application does not allow to configure system with Antenna height >30m AGL



### 12.1.4. FAILED REGISTRATION –CONTACT INFORMATION

#### TEST PROCEDURE

- Configure the base EUT with missing contact information, e.g. email.
- The TVWS application software cannot proceed with provisioning and prompts user to enter the missing information.
- Without provisioning the registration of the client EUT fails

#### RESULTS

TVWS Software didn't proceed with provisioning when contact information fields are missing. Base station does not proceed with registration without the provisioning information.

Test Results			
Pass	Fail	Tested By	Test Date
<input checked="" type="checkbox"/>	<input type="checkbox"/>	16080ZS	10/23/19

Contact information missing field

• EUT registration cannot happen without provisioning through the TVWS application (refer Theory of Operations)  
 • TVWS application does not allow provisioning with any missing contact information field

### Contact information missing field- registration failure

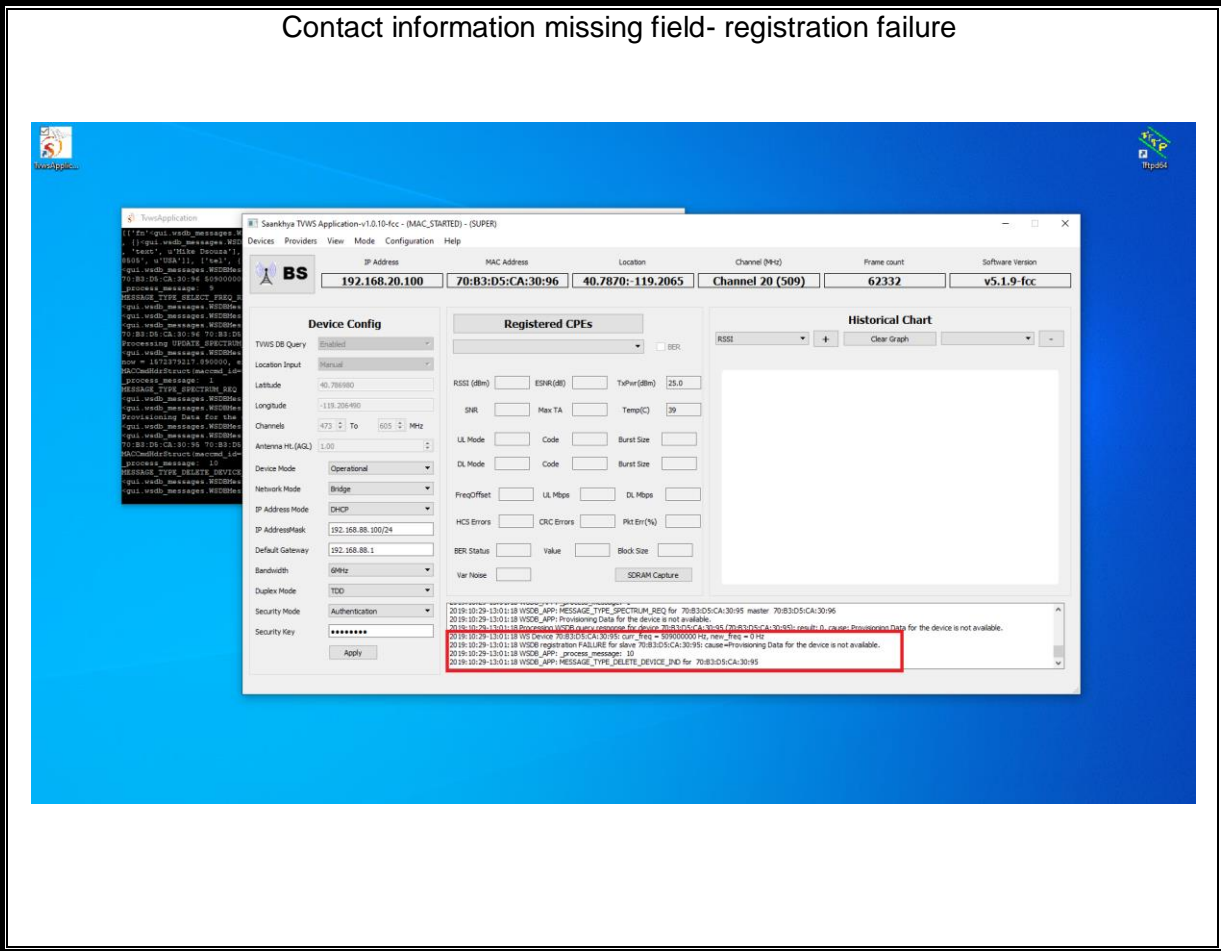

## 12.2. FIXED WSD CHANNELS OF OPERATION

### CLAUSES

- §15.711(c)(2)(ii)

### REQUIREMENT

Confirm that the device only operates on channels provided by the database

### TEST PROCEDURE

- The client EUT geographic coordinates are entered at registration time and stored in the device. The device channel list from the base unit request uses the same coordinates established at registration time. No separate coordinates can be entered for channel list request.
- The client device requires professional installation and device registration information including device location will be entered by the professional installer.
- Once the registration is complete, upon power cycling the client device will use the stored registration location for requesting channel list request.

### RESULTS

The client device only uses its configured location for channel list request. The device registered location will be established using GPS at installation time by a professional installer and re-acquires the new coordinates with included GPS receiver on sub-sequent reboots.

Test Results			
Pass	Fail	Tested By	Test Date
<input checked="" type="checkbox"/>	<input type="checkbox"/>	16080ZS	10/23/19

### Channel list after successful registration

Client cannot select channels from the database, but requests only the channel on which it is connected to its base

### Successful device registration with database

Successful device registration with database

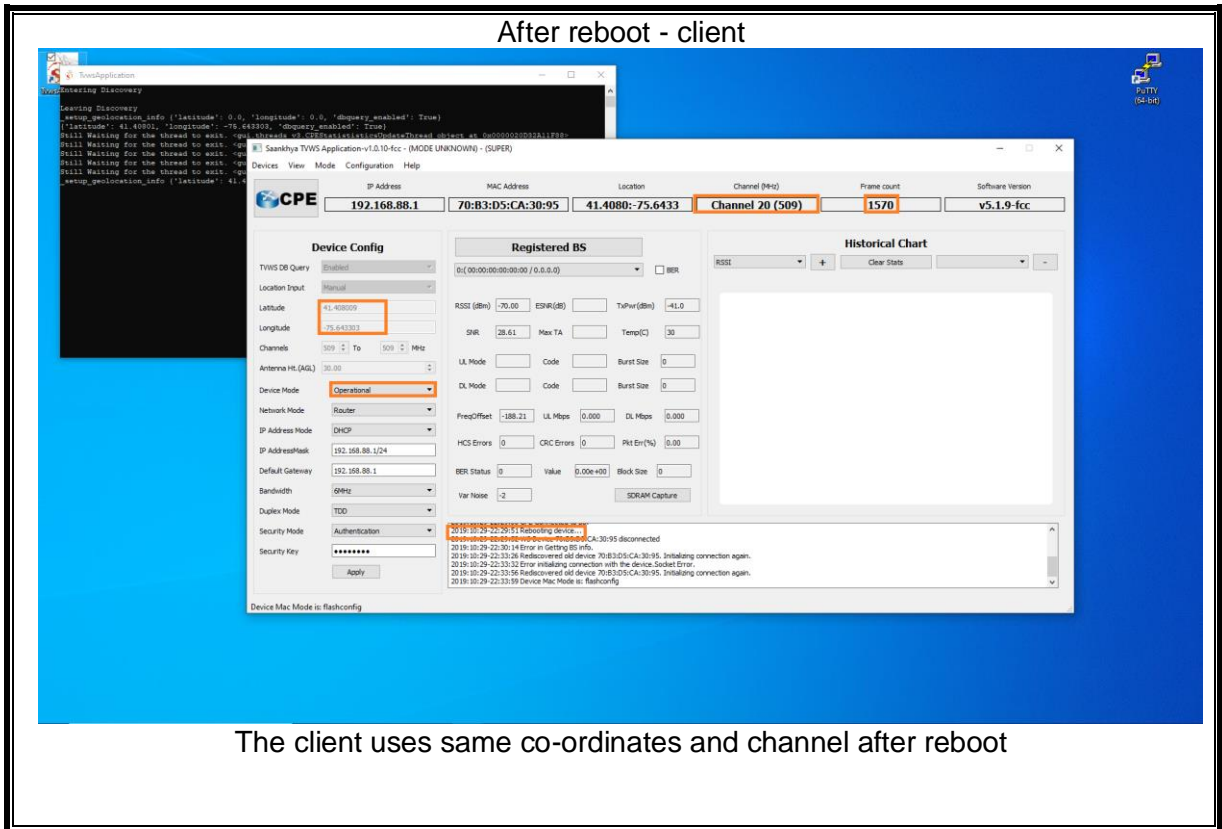
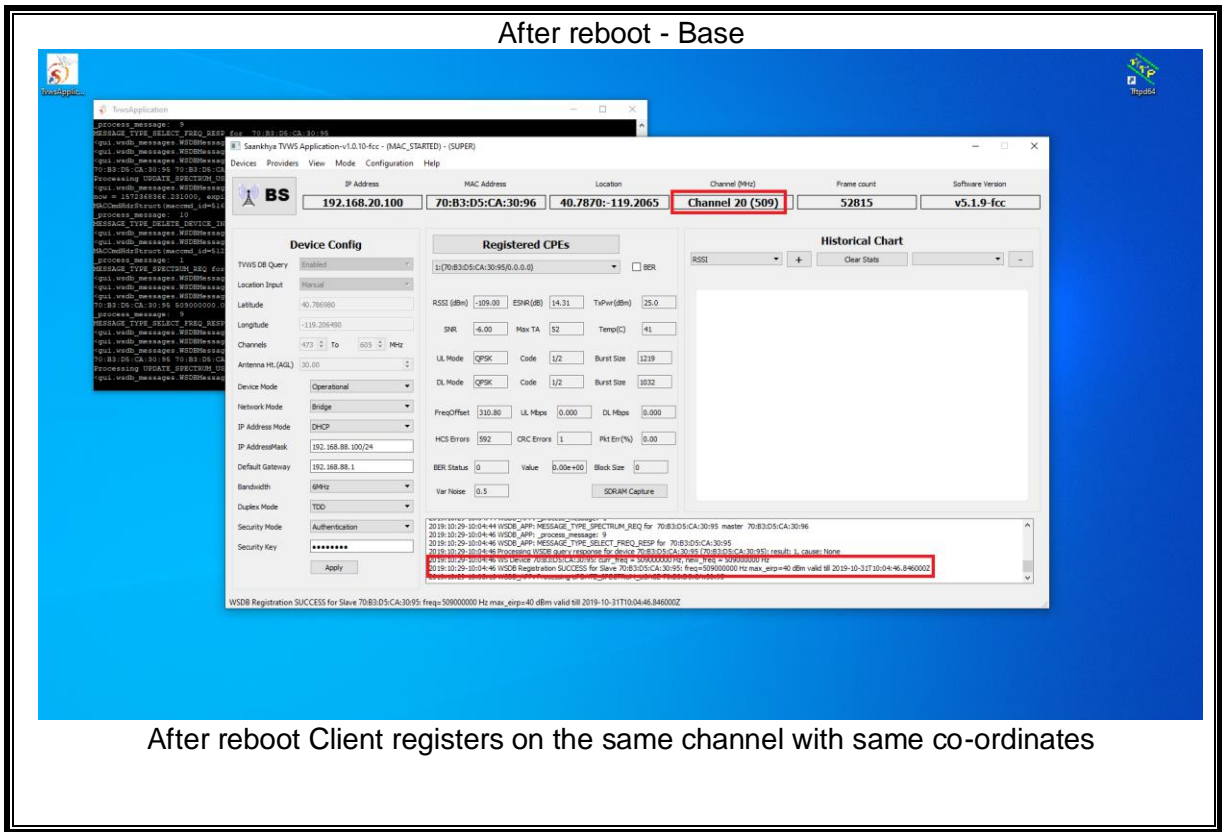

### 12.3. FIXED TVDB DATABASE UPDATE

#### CLAUSES

- §15.711(h)

#### REQUIREMENT

If a fixed or Mode II personal/portable TVBD fails to successfully contact the white space database during any given day, it may continue to operate until 11:59 p.m. of the following day at which time it must cease operations until it re-establishes contact with the white space database and re-verifies its list of available channels.

To simulate that the device fails to successfully contact the database, block access to the database from the WSD by removing connection to the database. All other radio functions, including internet connectivity should be maintained. Confirm that the WSD ceases operation by 11:59PM on the following day

#### TEST PROCEDURE

- Set the base EUT to normal operation mode:
  - Enter proper registration information on the base.
  - Client contacts the base to perform registration.
  - Base contacts database thru TVWS Application to perform client registration.
  - Base contacts database thru TVWS Application to retrieve client channel list.
  - Select an operating channel from returned channel list.
  - Client establishes link with base on selected channel
  - Base enables client transmission on selected channel.
- Observe the client EUT output signal on the spectrum analyzer.
- Use a programmable router to block the database URL.
- Observe that there is no output signal from the client after 11:59 PM on the following day.

#### RESULTS

During normal operation, the base and client channel lists are updated periodically by sending channel list requests to the TVWS Database. For test purposes this time period was shortened. After the database access was blocked, the next channel list requests failed and the EUTs stopped transmission immediately.

Test Results			
Pass	Fail	Tested By	Test Date
<input checked="" type="checkbox"/>	<input type="checkbox"/>	16080ZS	10/23/19

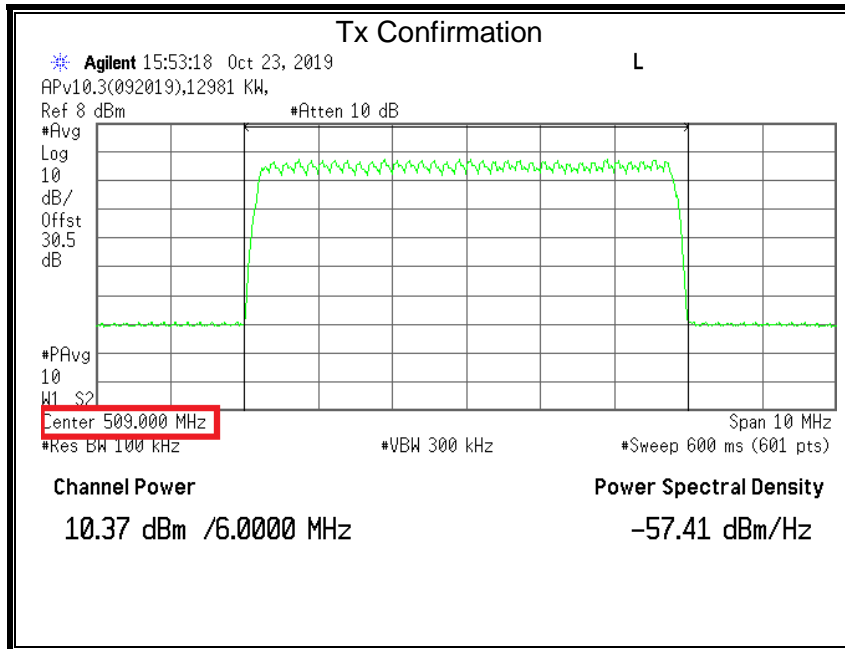
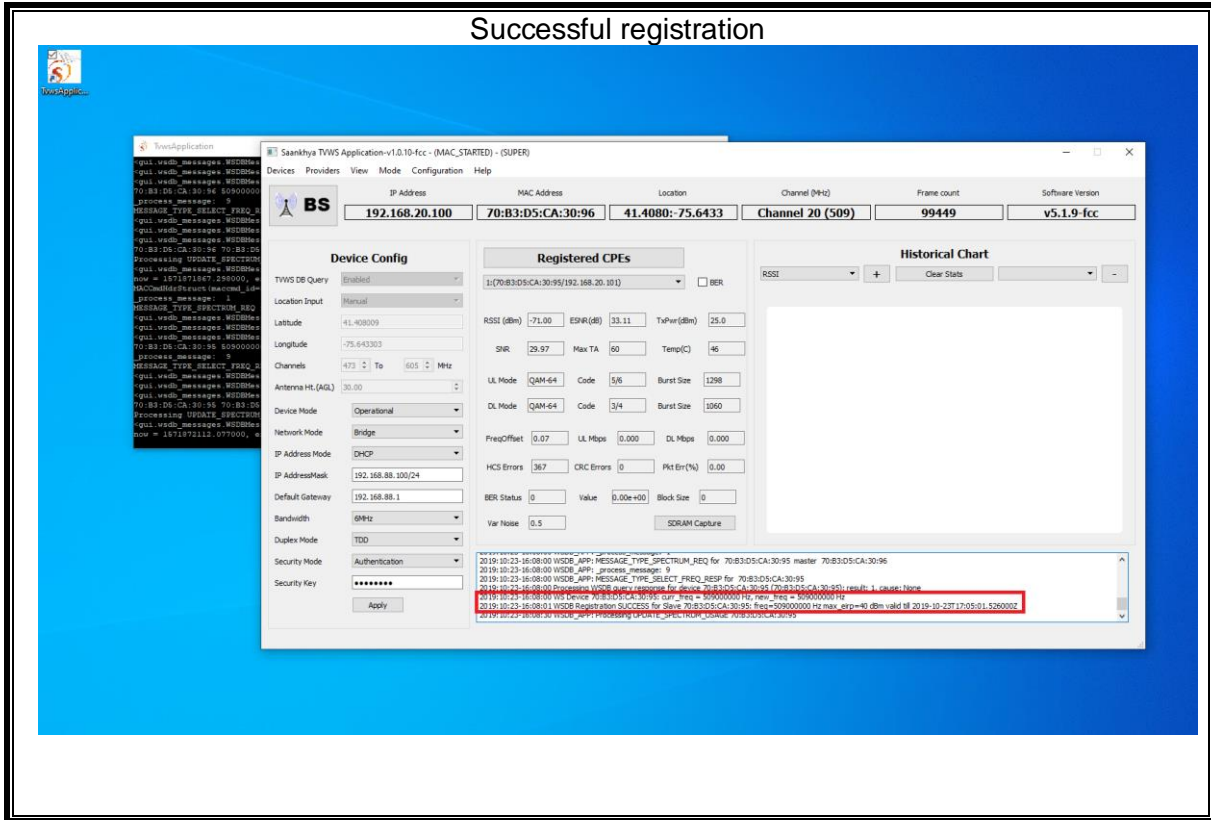



### Router blocking

**Base halts transmission of client when internet is not available to the base.**

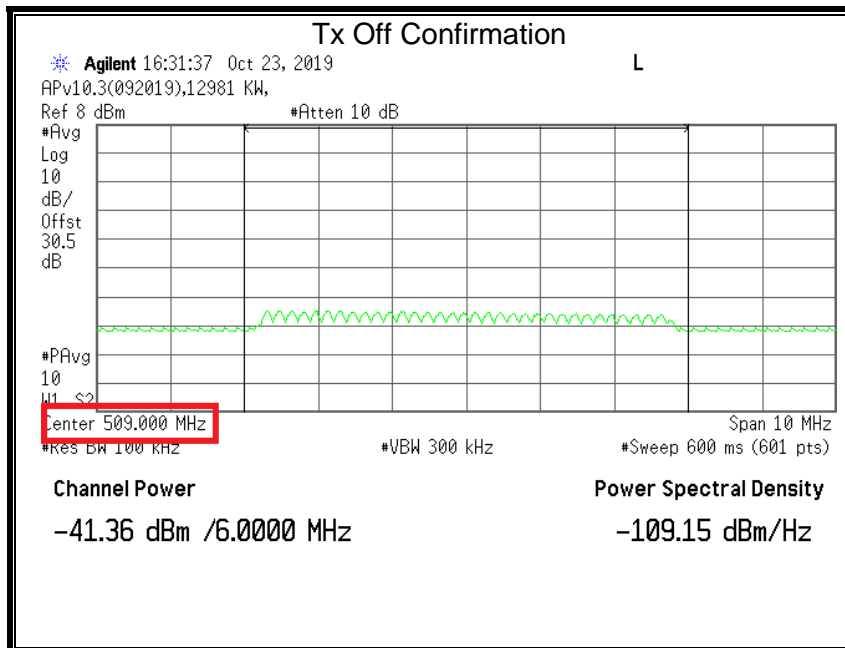



## 12.4. 48 HOUR CHANNEL SCHEDULING

### CLAUSES

- FCC §15.711(c)(2)(iii)
- FCC §15.713(a)(1)

### REQUIREMENT

Each fixed whitespace device shall access the database at least once a day to verify that the operating channels continue to remain available. Each fixed white space device must adjust its use of channels in accordance with channel availability schedule information provided by its database for the 48-hour period beginning at the time the device last accessed the database for a list of available channels.

After receiving an available channel list, register a low-power auxiliary device on the WSD operating channel to operate on an available channel and in the upcoming time period when the device will be tested. Repeat the available channel request after the update interval and in the time period when the low-power auxiliary device is scheduled to operate, and confirm that the low-power device is accounted for in the schedule. Using the system management software, confirm that the device changes channels at the scheduled time.

### TEST PROCEDURE

1. A lower power auxiliary devices are registered and scheduled for protection at both base and client locations
2. Allow the base and client EUT to enter normal operations prior to testing.
3. Upon channel list request to the TVWS Database, the base obtains the channel list expiration time reflecting the low power auxillary device's registered protection period for the client.
4. The base EUT requests new channel list upon the channel list for the client expiration time and the client EUT's current operation channel is no longer in the returned channel list.
5. The client EUT ceases transmission on the protected channel immediately.

Test Results			
Pass	Fail	Tested By	Test Date
<input checked="" type="checkbox"/>	<input type="checkbox"/>	16080ZS	10/24/19

### 12.4.1. RESULTS FOR CLIENT

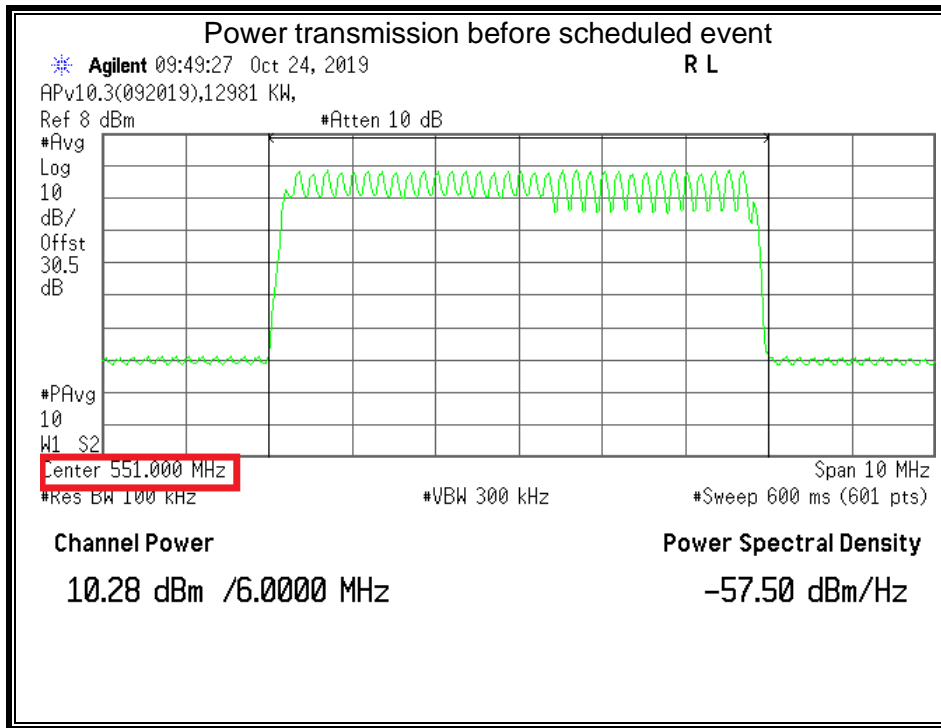

Scheduled Event – Client operational

Twosky TWSS Application-v1.0.10-fcc - (NORMAL) - (SUPER)

Devices View Mode Configuration Help

IP Address	MAC Address	Location	Channel (MHz)	Frame count	Software Version
192.168.88.1	70-B3-D5:CA:30-95	41.4080-75.6433	Channel 27 (551)	6903	v5.1.9-fcc

**Device Config**

TIWS DB Query: Enabled

Location Input: Manual

Latitude: 41.40801

Longitude: 75.64333

Channels: 551 To 551 MHz

Antenna Ht (AGL): 30.00

Device Mode: Operational

Network Mode: Router

IP Address Mode: DHCP

IP Address Mask: 192.168.88.1/24

Default Gateway: 192.168.88.1

Bandwidth: 6MHz

Duplex Mode: TDD

Security Mode: Authentication

Security Key: \*\*\*\*\*

Apply

CPE Connected to BS.

**Registered BS**

BS: 0 (70B3D5CA3096 / 0.0.0.0)

RSSI (dBm): -70.00 ESR(dB): TxPwr(dBm): 18.0

SNR: 29.08 Max TA: Temp(C): 28

UL Mode: QAM-64 Code: 5/6 Burst Size: 1298

DL Mode: QAM-64 Code: 5/6 Burst Size: 2566

FreqOffset: -196.52 UL Mbps: 0.538 DL Mbps: 0.191

HCS Errors: 3 CRC Errors: 2 PKT Err(%): 0.00

BER Status: 0 Value: 0.00e+00 Block Size: 0

Var Noise: 6.1e-05 SDRAM Capture

**Historical Chart**

2019-10-24-22:14:41 Reconnected old device 70-B3-D5:CA:30-95. Installing connection again.  
2019-10-24-22:14:44 Device Mac Mode is: atccrfg  
2019-10-24-22:14:44 Device is in installation mode.  
2019-10-24-22:15:22 Saving WSDM Params to Device.  
2019-10-24-22:15:22 Searching for Available Base Stations. This may take a while. Please Wait...  
2019-10-24-22:16:11 Attaching to BS with frequency 551.  
2019-10-24-22:17:26 CPE Connected to BS.

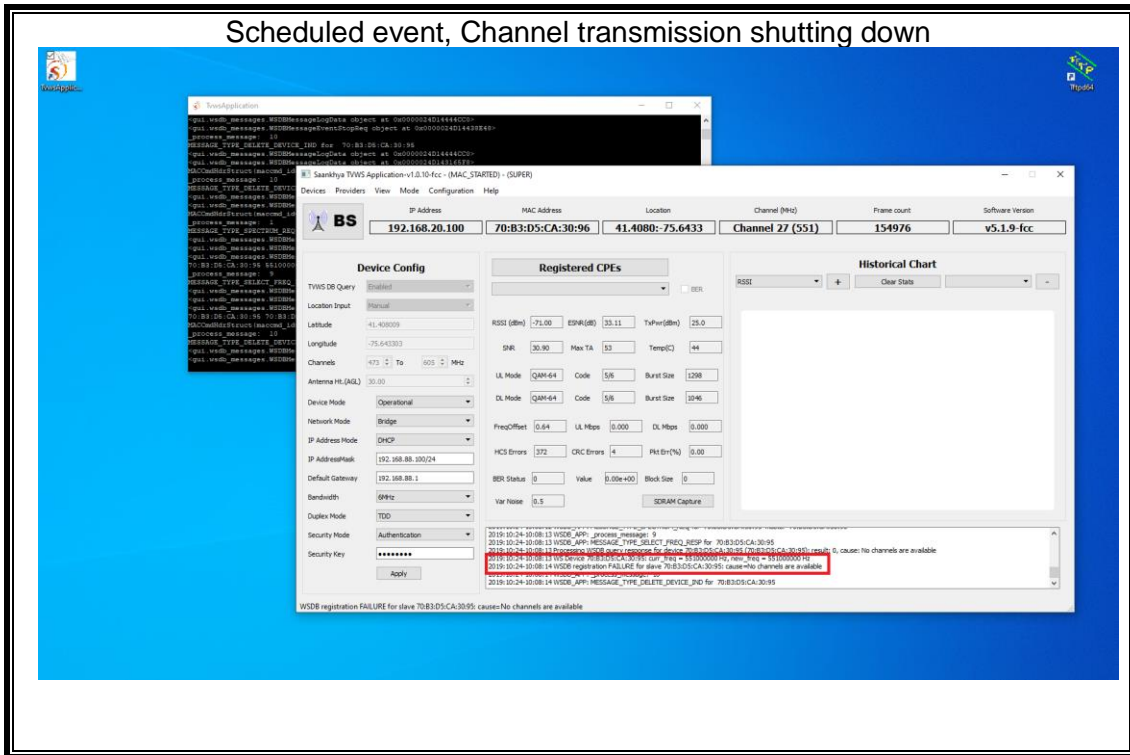
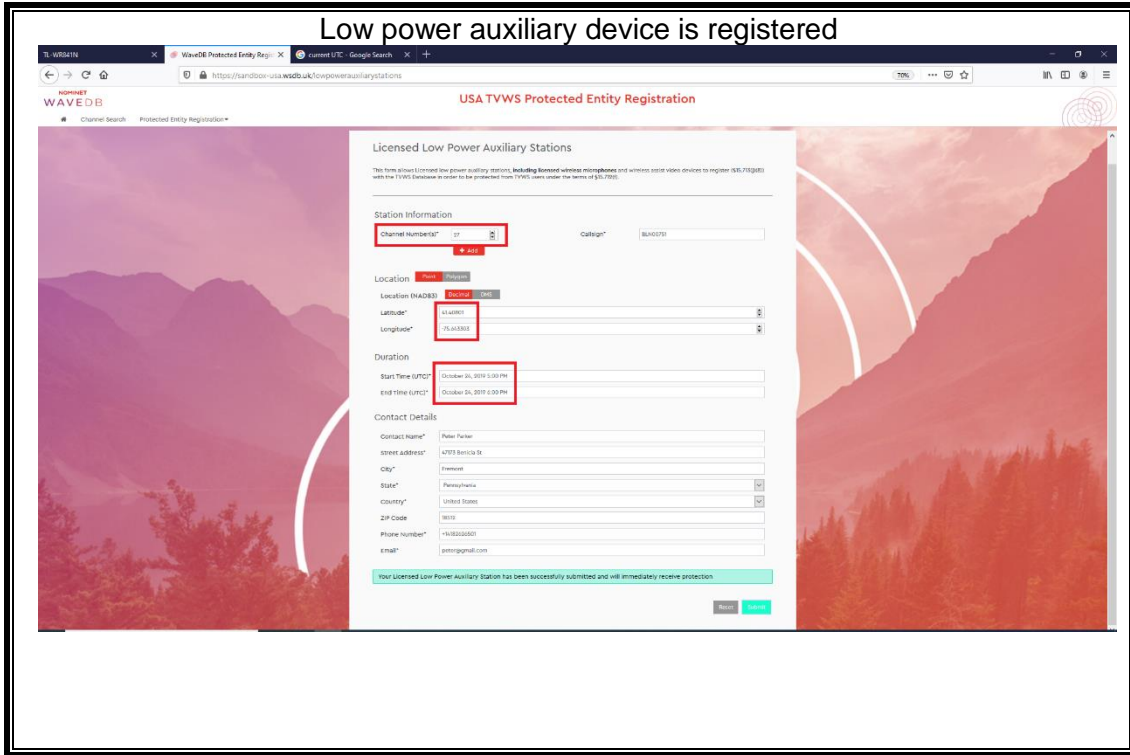

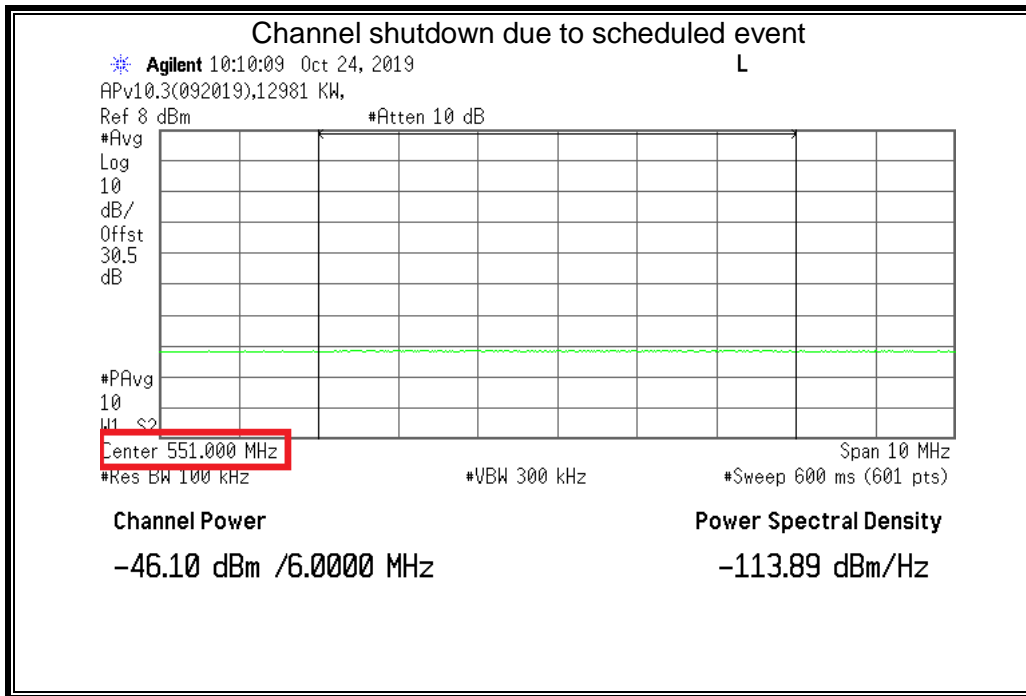

## 12.5. WSD CHANNEL AVAILABILITY

### CLAUSES

- FCC §15.707
- FCC §15.711(c)
- FCC §15.712

### REQUIREMENT

Confirm that WSD properly identifies itself as fixed or personal/portable to the database by comparing the channel list provided by the database with those allowable to the class of WSD under test. Confirm that the WSD is operating on a channel or channels from the list at the authorized power and cannot be made to operate on an unauthorized channel.

### TEST PROCEDURE

- Configure the base with correct registration information.
- The base automatically contacts the TVWS Database to perform device registration.
- Upon successful registration, base automatically contacts the TVWS Database to retrieve device channels for base and client.
- Upon successful registration the database also returns the allowable power according to the device type.
- Confirm the client EUT channel is same as base channel returned from the database which is within the device operating frequency range.
- Verify on the spectrum analyzer that the client EUT is operating on the selected channel

### RESULTS

The EUT operates on a channel from the authorized base channel list and at the authorized power level.

The EUT cannot select and operate on any channel other than those within the authorized channel list returned from the TVWS Database, which are within the device operating frequency range.

Test Results			
Pass	Fail	Tested By	Test Date
<input checked="" type="checkbox"/>	<input type="checkbox"/>	16080ZS	10/23/19

### Successful Device Registration with Database

The screenshot displays the configuration page for a device in the Spanktya TWVS Application. Key fields include:

- IP Address:** 192.168.20.100
- MAC Address:** 70:83:D5:CA:30:96
- Location:** 41.40880, -75.64333
- Channel (MHz):** Channel 20 (509) (highlighted in red)
- Frame count:** 99449
- Software Version:** v5.1.9-fcc

The 'Registered CPEs' table shows the following entry:

Device ID	MAC Address	Registration Status
1:70:83:D5:CA:30:96	70:83:D5:CA:30:96	Success

A log entry at the bottom of the interface is highlighted in red, indicating a successful registration: "2019-10-23 16:08:01 WSDR\_APP REGISTER\_SUCCESS for Spank 70:83:D5:CA:30:96, Reg=509000000 Hz, new\_Reg=509000000 Hz, valid till 2019-10-23T17:05:01.526000Z".

**Note, this channel is same channel as base device**

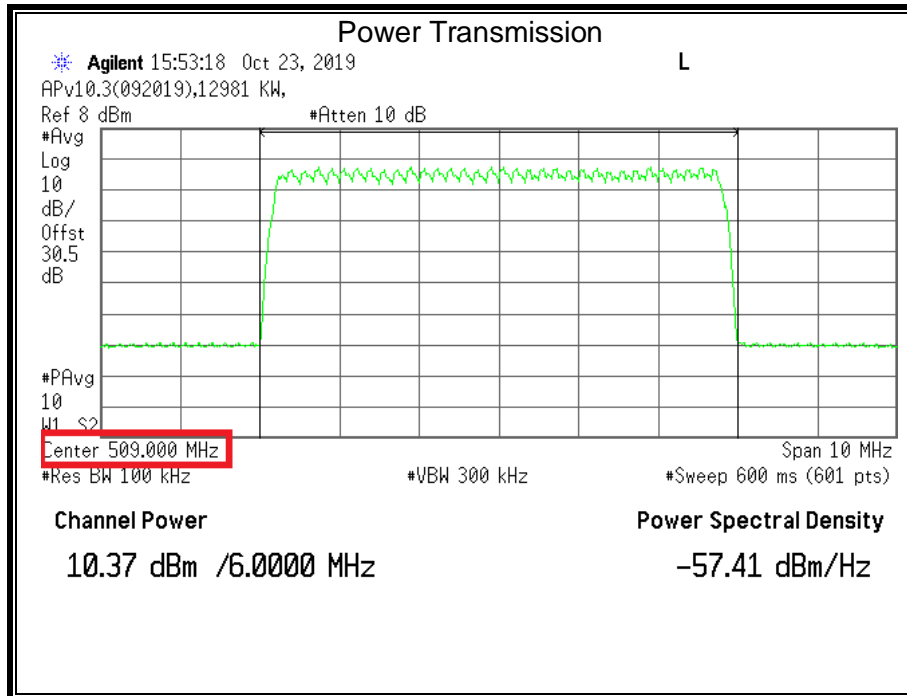

## 12.6. SECURITY

### CLAUSES

- §15.715(f)
- §15.713(i)
- §15.711(j)

### REQUIREMENT

The device operations procedures must include documentation with a detailed explanation of the following for each database the device is expected to work with:

- i. What communication protocol is used between the database and the WSD?
- ii. How are communications initiated?
- iii. How does the WSD validate messages from the database?
- iv. How does the device handle failure to communicate or authenticate the database?
- v. How does the database validate messages from a WSD?
- vi. What encryption method is used?
- vii. How does the database ensure secure registration of protected devices?

### ANSWERS

- i. What communication protocol is used between the database and the WSD?**  
HTTPS is the communication protocol used between the database and the WSD
  
- ii. How are communications initiated?**  
The TV whitespace device will initiate the communication by sending available spectrum request. The details of the device included in the message helps WSDB server to uniquely identify the device and respond back with channels available for operation
  
- iii. How does the WSD validate messages from the database?**  
The TV white space device will first check for the HTTP response code. If the 200 code is not received, the device will continue to try again. If the 200 code is received, the device will proceed to check if the response from the database in correct XML format and if it is using the format that is specified by the database. As the communication is done using HTTPS protocol, the messages will be encrypted, hence it will ensure the confidentiality and integrity of data
  
- iv. How does the device handle failure to communicate or authenticate the database?**  
The device will stop its transmission immediately if it failed to communicate or authenticate with the database. This also results in rebooting of the device under certain circumstances
  
- v. How does the database validate messages from a WSD?**  
The database requires the WSD to be pre-enrolled before it will send any response to request. Hence, it will first check to see if device has been pre-enrolled. Next the database will validate the message received to see if it conforms to the specification of the request

definition on whether that field is mandatory or optional field. Lastly, it will validate the message content.

**vi. What encryption method is used?**

TLS is used as a support layer to HTTPS, SSLV2

**vii. How does the database ensure secure registration of protected devices?**

Protected devices are registered via a web form secured by HTTPS.



## 12.7. Push notification to Fixed

### CLAUSES

- §15.711(i)

### REQUIREMENT

Confirm that the WSD device changes channels (or cease operation) when it receives 'push' notification from the database.

Using system management software, register the device at (specific coordinates) and wait for the database to send a push notification. Confirm that, once the notification is received, the device responds to the new channel availability list provided by the database, which would include ceasing operation on a channel no longer available, or ceases operation.

### TEST PROCEDURE

- Obtain a successful registration to the database.
- Transmit on allocated channel
- Wait for database to send a push notification to cease operation on desired channel
- Confirm that once the push notification is received, a new channel availability list is provided and the desired channel ceases operation.

Test Results			
Pass	Fail	Tested By	Test Date
<input checked="" type="checkbox"/>	<input type="checkbox"/>	16080ZS	10/28/19

As per the waiver DA-19-960A1 issued by FCC on September 25, 2019, this test is waived till March 31, 2020 for base and client units

## **12.8. Location accuracy**

### **CLAUSES**

- §15.711(b)

### **REQUIREMENT**

For Fixed and Mode II devices, provide details regarding the technologies used by the device to determine its location and how, in case of other than GPS technology, the location uncertainty is calculated with a 95% confidence level

### **RESULTS**

EUT uses GPS technology for determining location.

## **12.9. Interference protection requirement**

### **CLAUSES**

- §15.712

### **REQUIREMENT**

Using system management software or database, provide different location (coordinates) so that compliance with operating channel and power level is shown under each of the scenarios outlines in §15.712. Include a sample scan showing the total channel power and adjacent channel emission settings for test coordinates.

### **TEST PROCEDURE**

For the scenarios listed below confirm there is no allowance of transmission on specific channels according to that particular location

#### Scenarios

- a) Digital television stations, and digital and analog Class A TV, low power TV, TV translator and TV booster stations
- b) TV translator, Low power TV(including Class A) and Multi-channel Video Programming Distributor (MVPD)
- c) Fixed Broadcast Auxiliary Service (BAS) links
- d) PLMR/CMRS operations
- e) Offshore Radiotelephone Service
- f) Low power auxiliary services including wireless microphones
- g) Border areas near Canada and Mexico
- h) Radio astronomy services
- i) 600 Mhz service band
- j) Wireless Medical Telemetry Service
- k) 488-494 MHz band in Hawaii

### **RESULTS**

Scenario		Coordinate	Note
a	Digital television stations, and digital and analog Class A TV, low power TV, TV translator and TV booster stations	35.775, -106.24555 (UHF)	UHF No transmission allowed
b	TV translator, Low power TV(including Class A) and Multi-channel Video Programming Distributor (MVPD)	43.80102, -111.778 (UHF)	UHF coordinate cannot transmit Ch. 23
c	Fixed Broadcast Auxiliary Service (BAS) links	41.890417, -87.623694	Cannot transmit on Ch. 28
d	PLMR/CMRS operations	38.954722, -77.004722	Cannot transmit on Ch. 17 and 18
e	Offshore Radio telephone Service	38.954722, -77.004722	Cannot transmit on Ch. 17 and 18
f	Low power auxiliary services including wireless microphones	N/A	48 hour channel scheduling requirement was based off this scenario
g	Border areas near Canada and Mexico	32.608179, -116.969585	Cannot transmit on Ch. 6 and 32
h	Radio astronomy services	35.775, -106.24555	No channels available
i	600 MHz service band	40.78698, -119.206486	Cannot transmit on Ch. 37 and 38 Note EUT does not operate beyond channels 36(608MHz)
j	Wireless Medical Telemetry Service	N/A	EUT does not support transmission in this frequency band
k	488-494 MHz band in Hawaii	20.88, -156.678611	Cannot transmit on Ch. 17

Test Results			
Pass	Fail	Tested By	Test Date
<input checked="" type="checkbox"/>	<input type="checkbox"/>	16080ZS	10/28/19

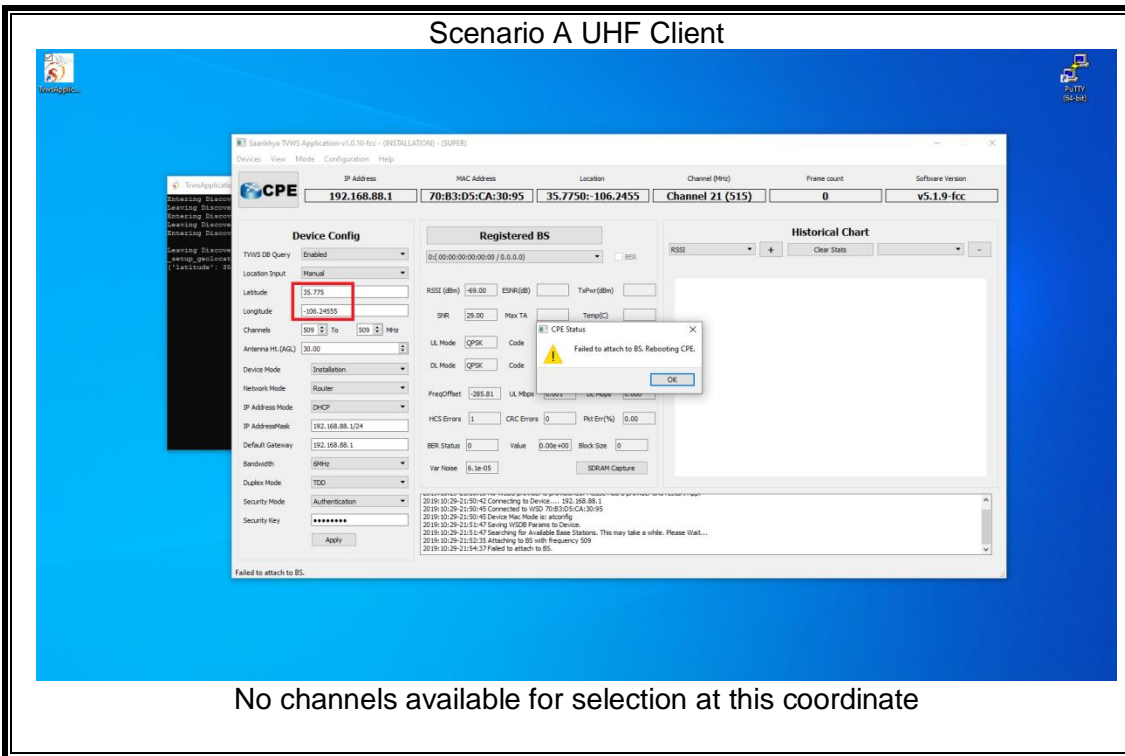
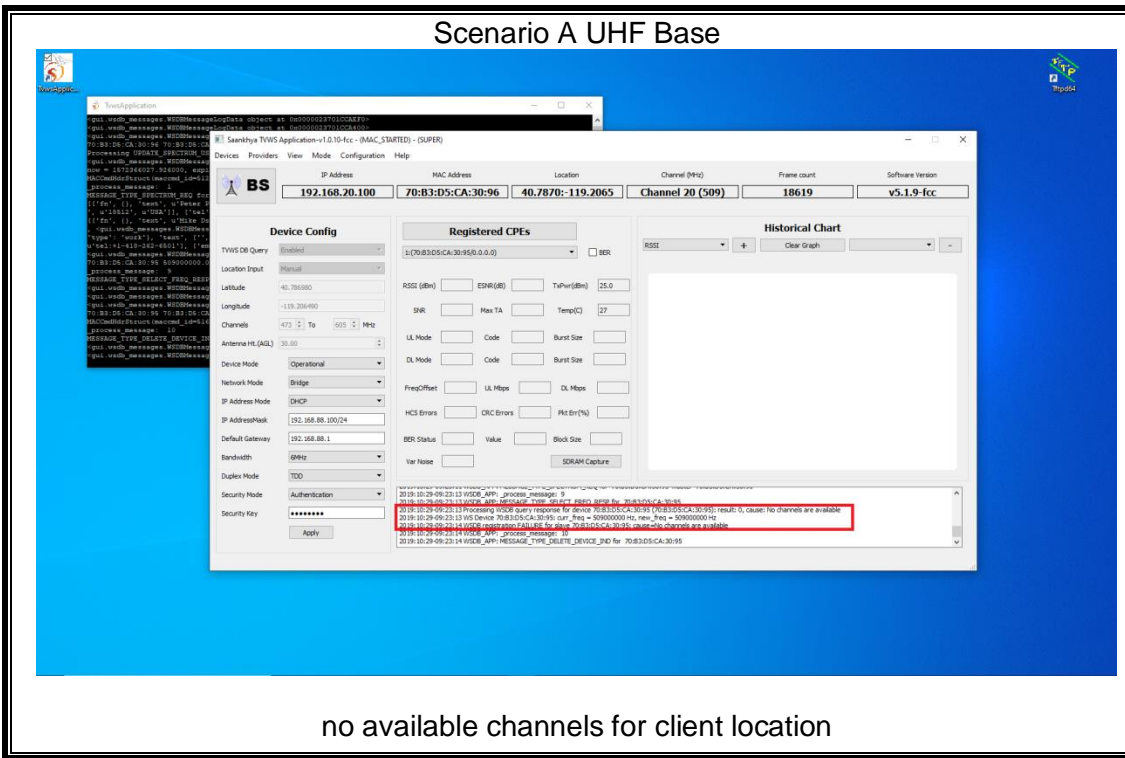

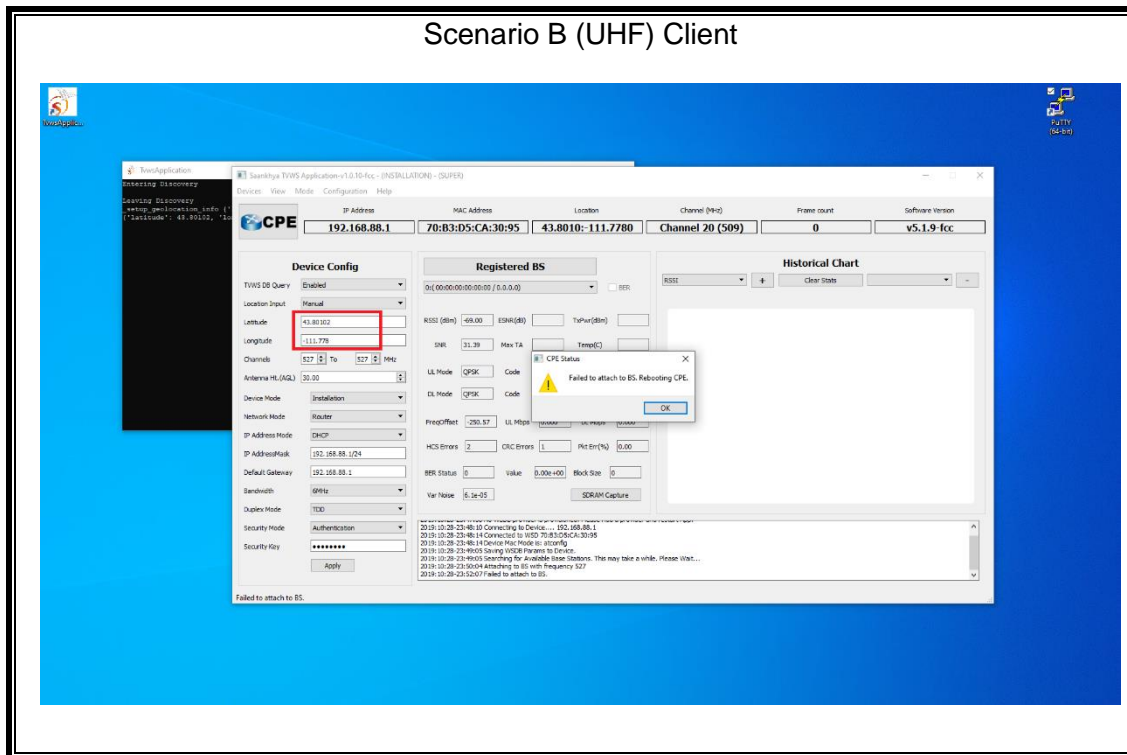
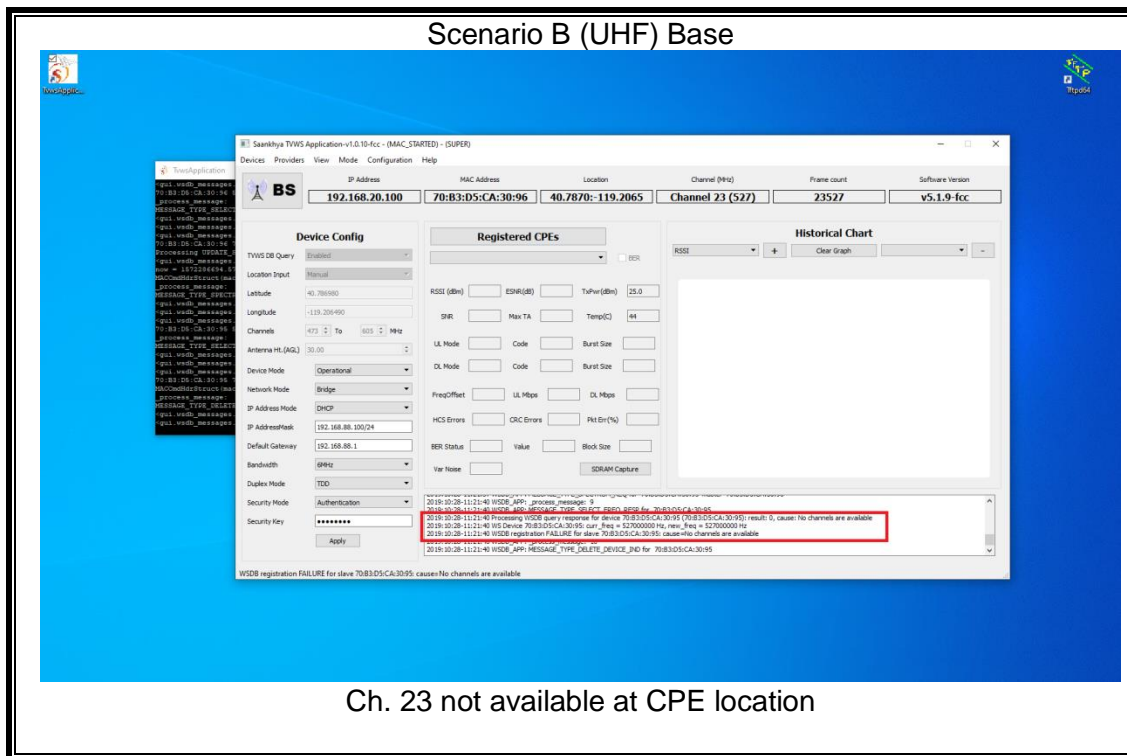

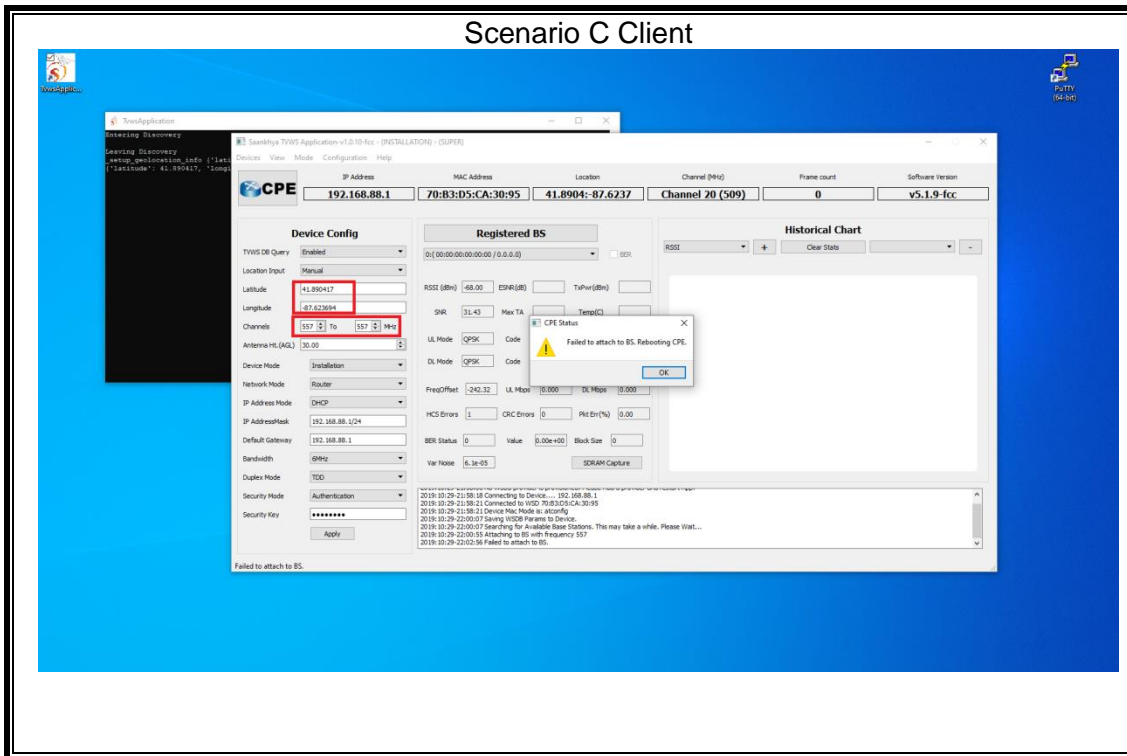
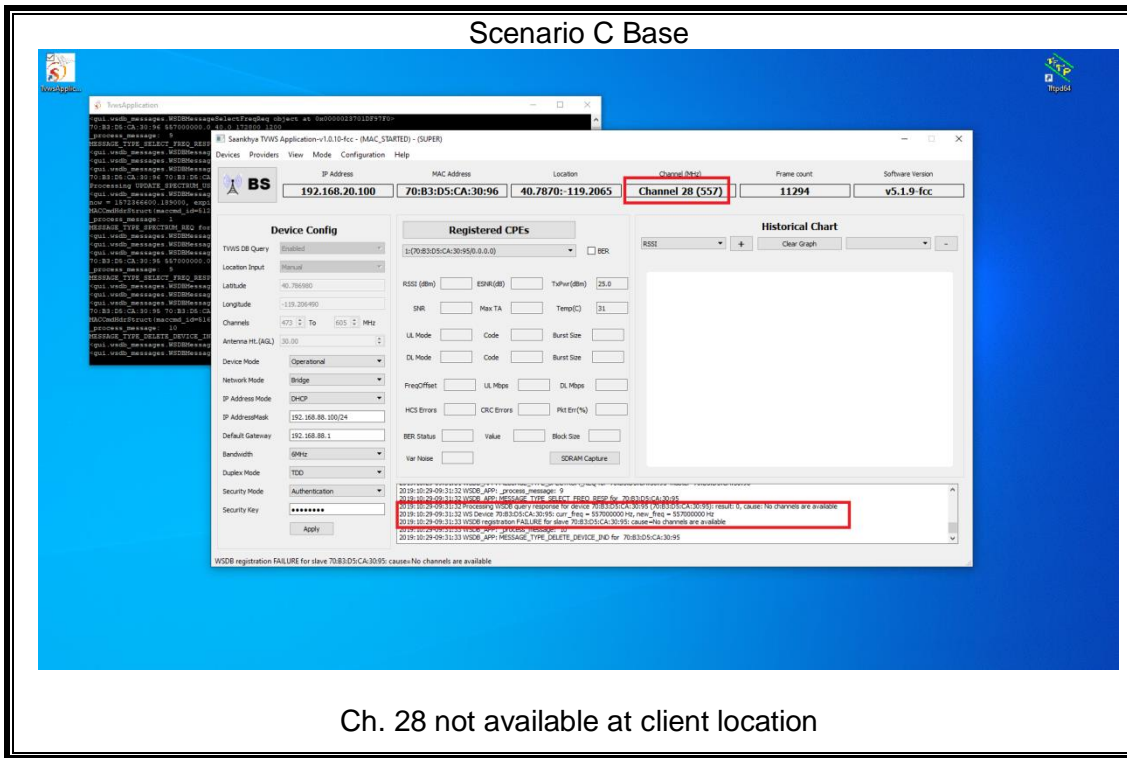

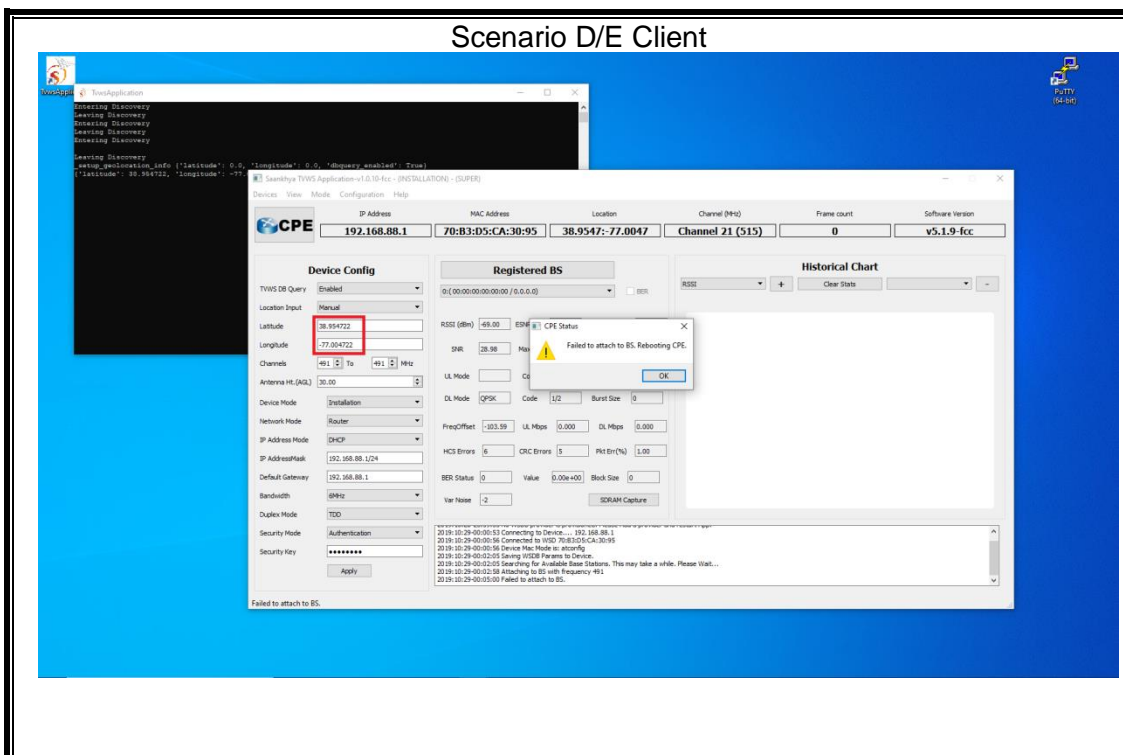
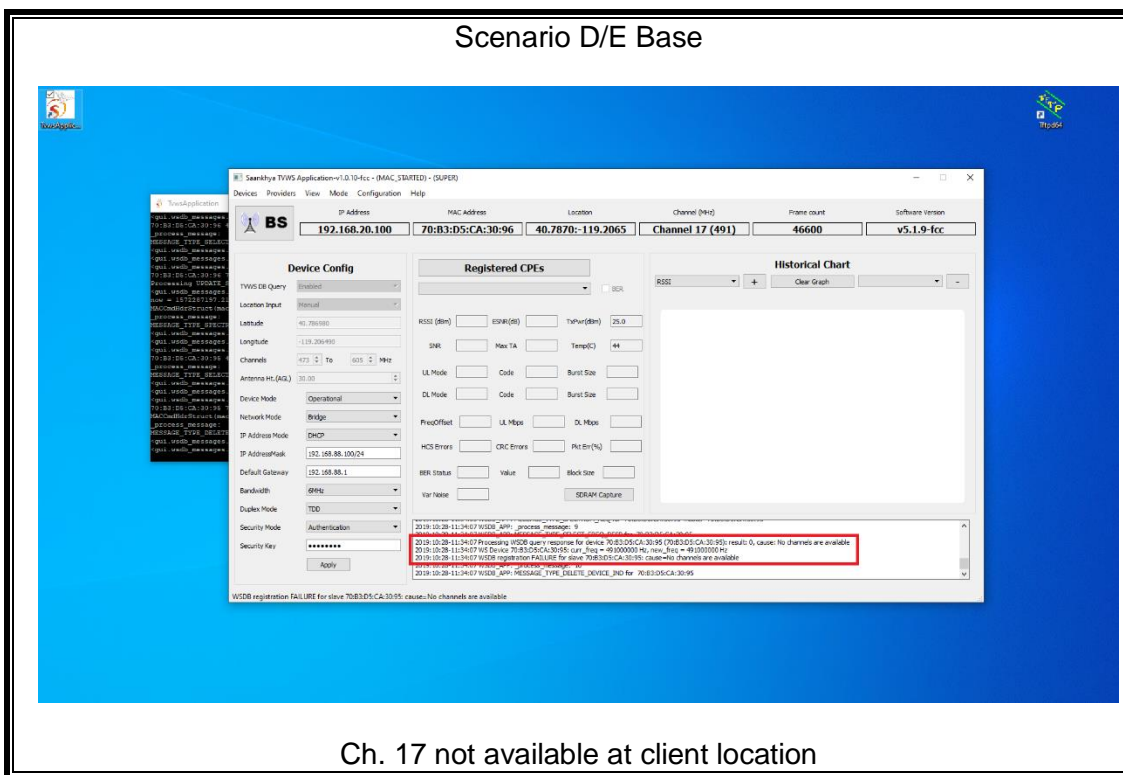





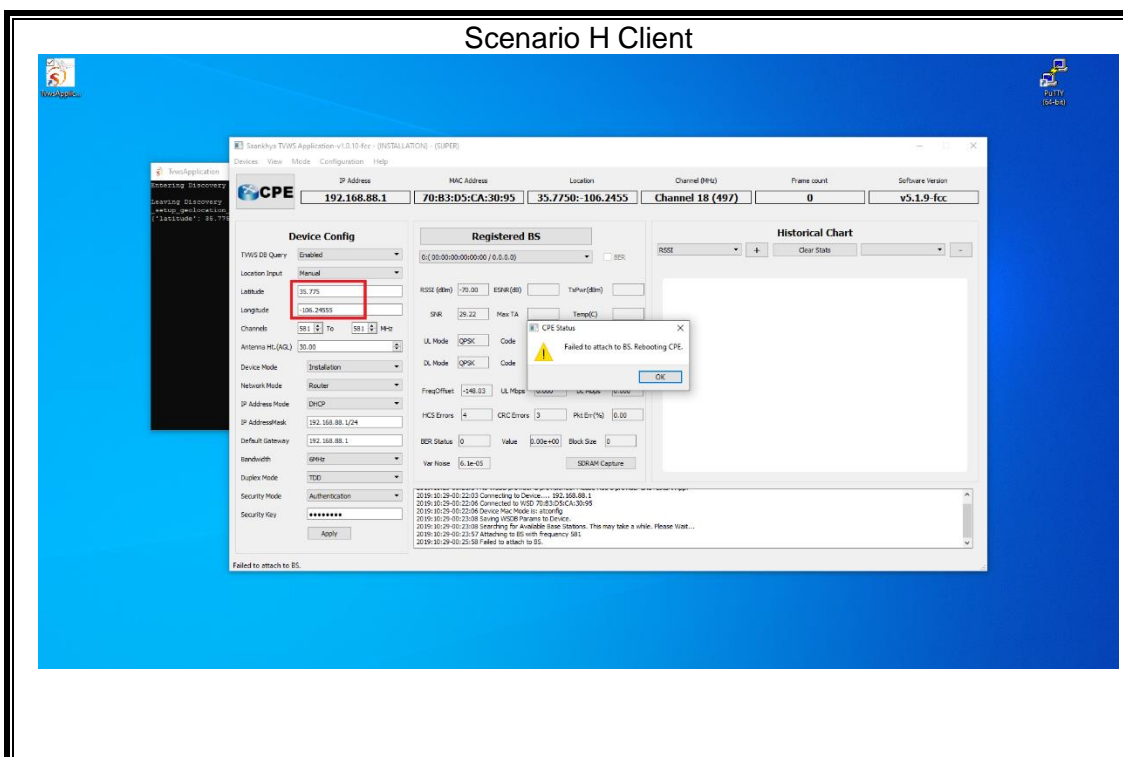
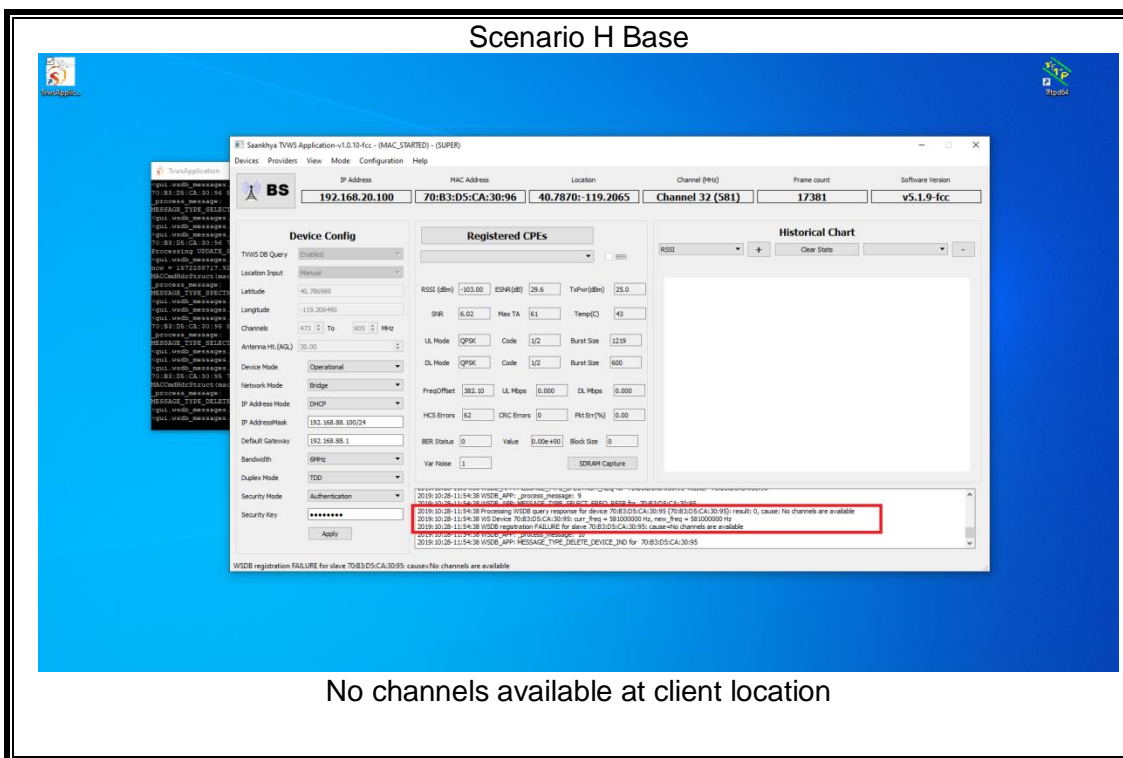

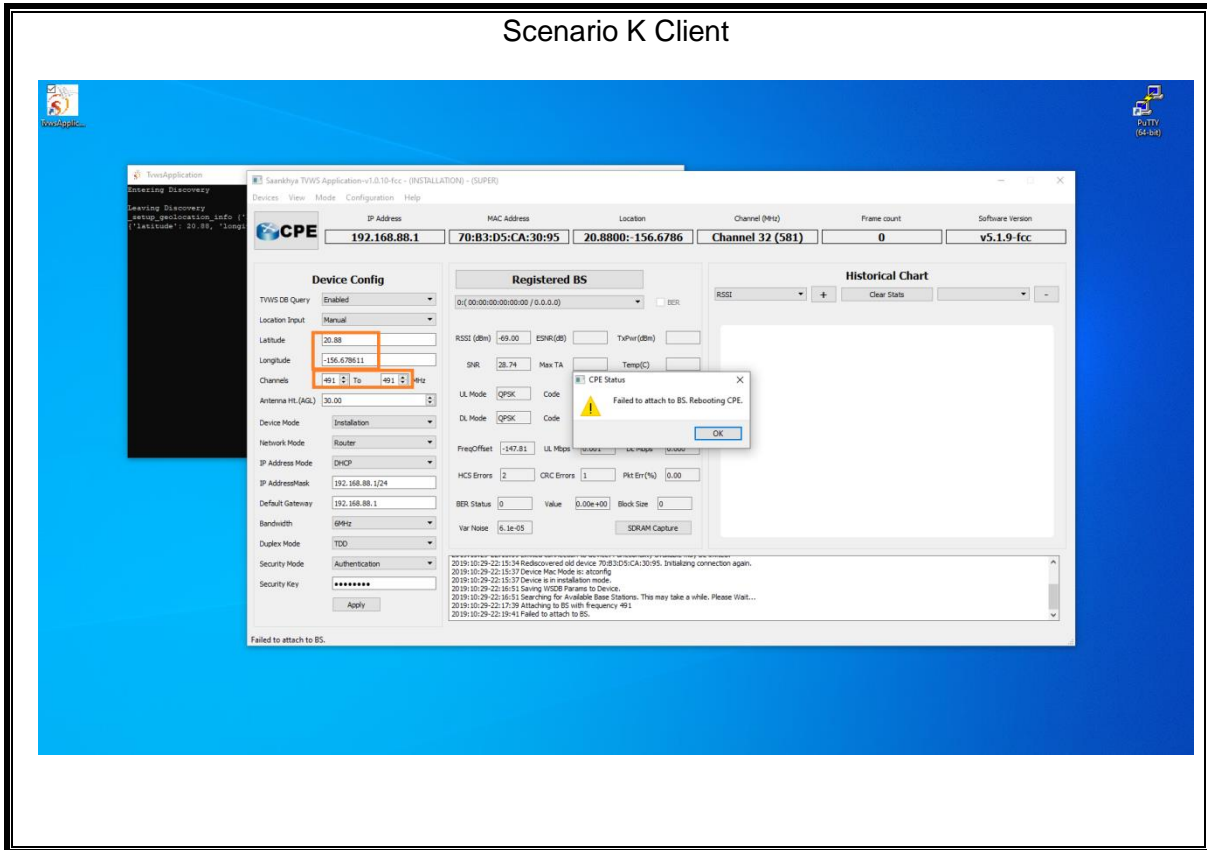
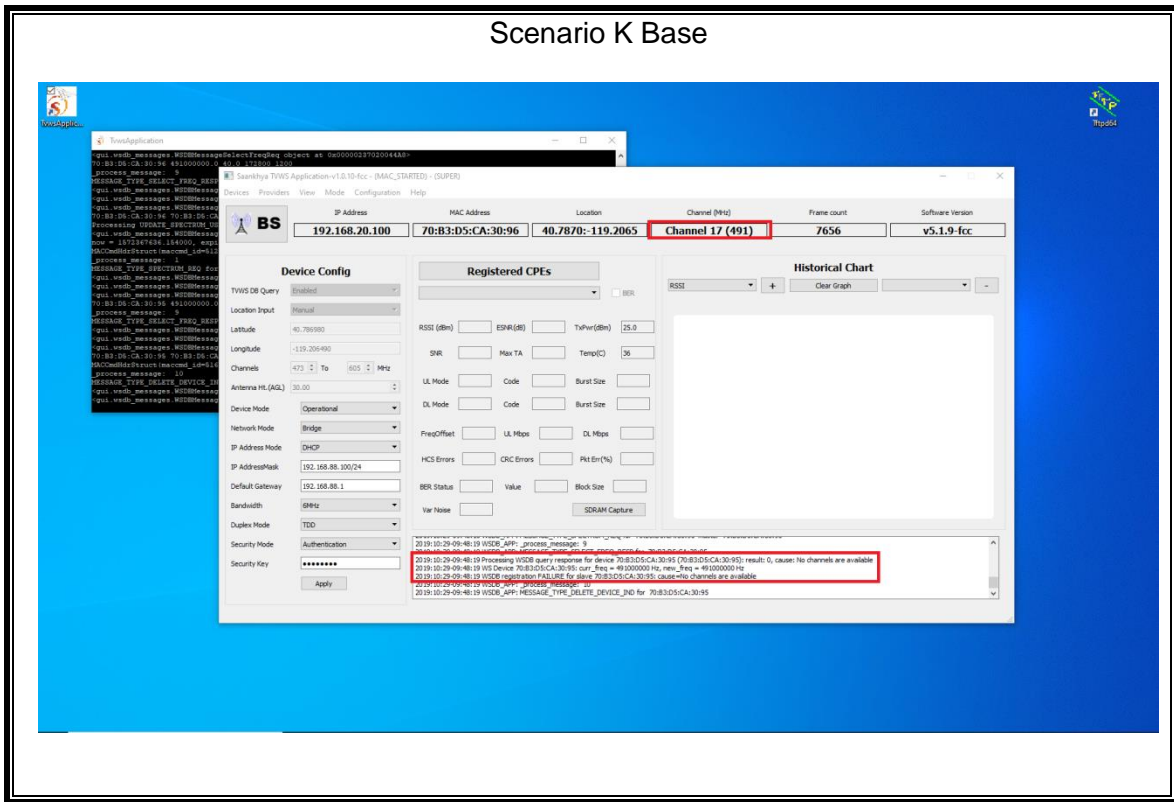

## 12.10. Fixed Power level reduction

### CLAUSES

- §15.711(c)(2)(ii)
- §15.715(e)

### REQUIREMENT

Using system management software, make a channel availability request to the database. Using the spectrum analyzer, confirm that the WSD operates at no more than the maximum power level indicated by the database and that the power level cannot be set to a higher level than indicated by the database at that specific location. If the device cannot reduce power, it must cease operation.

### TEST PROCEDURE

- Create a successful registration with the database
- Transmit at allowed channel for client device
- Confirm with spectrum analyzer that the EUT does not operate more than the max power level indicated by the database.
- Confirm power level cannot be set higher than the level indicated by the database

### RESULTS

Test Results			
Pass	Fail	Tested By	Test Date
<input checked="" type="checkbox"/>	<input type="checkbox"/>	16080ZS	10/24/19

