

---

# FCC Test Report

---

Report No.: AGC09128190903FE08

**FCC ID** : 2AUMTWT-UV5FPLUS  
**PRODUCT DESIGNATION** : Two way radio  
**BRAND NAME** : Wanneton, Airtion, GUUGEI  
**MODEL NAME** : WT-UV5F Plus, WT-UV5F, AI-5, GF-UV5F, X5, WT-S5,  
WT-5S, GMR-5F, GT-5F, R5  
**APPLICANT** : Quanzhou Wanneton Electronic&Technology Co.,Ltd  
**DATE OF ISSUE** : Oct. 22, 2019  
**STANDARD(S)** : FCC Part 15 Rules  
**REPORT VERSION** : V 1.0

## Attestation of Global Compliance (Shenzhen) Co., Ltd

**CAUTION:**

This report shall not be reproduced except in full without the written permission of the test laboratory and shall not be quoted out of context.



**Report Revise Record**

Report Version	Revise Time	Issued Date	Valid Version	Notes
V1.0	/	Oct. 22, 2019	Valid	Initial Release



## TABLE OF CONTENTS

<b>1. VERIFICATION OF COMPLIANCE</b> .....	<b>4</b>
<b>2. PRODUCT INFORMATION</b> .....	<b>5</b>
<b>3. IDENTIFICATION OF THE RESPONSIBLE TESTING LOCATION</b> .....	<b>6</b>
<b>4. SUPPORT EQUIPMENT LIST</b> .....	<b>7</b>
<b>5. SYSTEM DESCRIPTION</b> .....	<b>7</b>
<b>6. SUMMARY OF TEST RESULTS</b> .....	<b>8</b>
<b>7. FCC RADIATED EMISSION TEST</b> .....	<b>9</b>
7.1. TEST EQUIPMENT OF RADIATED EMISSION .....	9
7.2. LIMITS OF RADIATED EMISSION TEST .....	9
7.3 BLOCK DIAGRAM OF RADIATED EMISSION TEST .....	9
7.4 PROCEDURE OF RADIATED EMISSION TEST .....	11
7.5 TEST RESULT OF RADIATED EMISSION TEST .....	12
<b>8. CONDUCTED EMISSION TEST</b> .....	<b>14</b>
8.1 PROVISIONS APPLICABLE .....	14
8.2 MEASUREMENT PROCEDURE .....	14
8.3 TEST SETUP BLOCK DIAGRAM .....	15
8.4 TEST RESULT .....	16
<b>9. ANTENNA CONDUCTED POWER FOR RECEIVERS</b> .....	<b>18</b>
<b>10. SANNING RECEIVERS AND FREQUENCY CONVERTERS USED WITH SANNING RECEIVERS.</b> .....	<b>21</b>
<b>APPENDIX 1 PHOTOGRAPHS OF TEST SETUP</b> .....	<b>23</b>
<b>APPENDIX 2 PHOTOGRAPHS OF EUT</b> .....	<b>25</b>



### 1. VERIFICATION OF COMPLIANCE

<b>Applicant</b>	Quanzhou Wanneton Electronic&Technology Co.,Ltd
<b>Address</b>	Baijie International Centre ,Qiaonan District, Chidian Town, Quanzhou, China
<b>Manufacturer</b>	Quanzhou Wanneton Electronic&Technology Co.,Ltd
<b>Address</b>	Baijie International Centre ,Qiaonan District, Chidian Town, Quanzhou, China
<b>Factory</b>	Quanzhou Wanneton Electronic&Technology Co.,Ltd
<b>Address</b>	Baijie International Centre ,Qiaonan District, Chidian Town, Quanzhou, China
<b>Product Designation</b>	Two way radio
<b>Brand name</b>	Wanneton, Airtion, GUUGEI
<b>Test Model</b>	WT-UV5F Plus
<b>Serial Model</b>	WT-UV5F, AI-5, GF-UV5F, X5, WT-S5, WT-5S, GMR-5F, GT-5F, R5
<b>Serial Model Difference</b>	Only model and Brand are different; Wanneton models are WT-UV5F Plus, WT-UV5F, X5, WT-S5, WT-5S, GMR-5F, GT-5F, R5 ; Airtion model is AI-5; GUUGEI model is GF-UV5F;
<b>Hardware Version</b>	VER3.2
<b>Software Version</b>	V1.0
<b>Measurement Procedure</b>	ANSI C63.4: 2014
<b>Date of test:</b>	Sep. 18, 2019~Oct. 22, 2019
<b>Deviation:</b>	None
<b>Condition of Test Sample</b>	Normal

The above equipment was tested by Attestation Of Global Compliance (Shenzhen) Co., Ltd. for compliance with the requirements set forth in the FCC Rules and Regulations Part 15, the measurement procedure according to ANSI C63.4:2014. This said equipment in the configuration described in this report shows the maximum emission levels emanating from equipment are within the compliance requirements. The test results of this report relate only to the tested sample identified in this report.

Prepared By Calvin Liu  
 Calvin Liu  
 (Project Engineer) Oct. 22, 2019

Reviewed By Max Zhang  
 Max Zhang  
 (Reviewer) Oct. 22, 2019

Approved By Forrest Lei  
 Forrest Lei  
 Authorized Officer Oct. 22, 2019



## 2. PRODUCT INFORMATION

The EUT is a **Two way radio** designed for voice communication. It is designed by way of utilizing the F3E modulation achieves the system operating.

A major technical description of EUT is described as following:

<b>Communication Type</b>	Voice / Tone only
<b>Modulation</b>	FM
<b>RX Frequency Range</b>	VHF:136MHz-174MHz UHF: 400MHz -480MHz
<b>Emission Type</b>	F3E
<b>Antenna Designation</b>	Detachable
<b>Antenna Gain</b>	0dBi
<b>Adapter Parameter</b>	Input: AC 110V-230V 50/60Hz, 0.2A Output: DC 10V 500mA
<b>Charger Parameter</b>	Input: DC 10V 500mA Output: 8.5V 500mA
<b>Power Supply</b>	DC 7.4V 1400mAh

I/O Port Information (Applicable Not Applicable)

I/O Port of EUT			
I/O Port Type	Q'TY	Cable	Tested with
Antenna Connect Port	1	0	1



### 3. IDENTIFICATION OF THE RESPONSIBLE TESTING LOCATION

<b>Test Site</b>	Attestation of Global Compliance (Shenzhen) Co., Ltd
<b>Location</b>	1-2/F, Building 19, Junfeng Industrial Park, Chongqing Road, Heping Community, Fuhai Street, Bao'an District, Shenzhen, Guangdong, China
<b>Designation Number</b>	CN1259
<b>FCC Test Firm Registration Number</b>	975832
<b>A2LA Cert. No.</b>	5054.02
<b>Description</b>	Attestation of Global Compliance(Shenzhen) Co., Ltd is accredited by A2LA

#### List Of Test Equipment:

##### TEST EQUIPMENT OF CONDUCTED EMISSION TEST

Equipment	Manufacturer	Model	S/N	Cal. Date	Cal. Due
TEST RECEIVER	R&S	ESCI	100096	Jul. 12, 2019	Jul. 11, 2020
TEST RECEIVER	R&S	ESCI	100096	Jul. 12, 2019	Jul. 11, 2020
AMN/LISN	R&S	ESH2-Z5	100086	Aug. 22, 2019	Aug. 21, 2020
TEST SOFTWARE	FR	EZ-EMC	AGC-CON03 A	--	--

##### TEST EQUIPMENT OF RADIATED EMISSION TEST

Equipment	Manufacturer	Model	S/N	Cal. Date	Cal. Due
TEST RECEIVER	R&S	ESPI	101206	Jul. 12, 2019	Jul. 11, 2020
ANTENNA	SCHWARZBECK	VULB9168	494	Sep. 25, 2019	Sep. 24, 2021
TEST RECEIVER	R&S	ESCI	100694	June 27, 2019	June 26, 2020
ANTENNA	SCHWARZBECK	VULB9168	D69250	Sep. 25, 2019	Sep. 24, 2021
POSITIONING CONTROLLER	MF	MF-7802	MF780208285	--	--
HORN ANTENNA	ETS LINDGREN	3117	00034609	May. 15, 2019	May. 14, 2021
RF Communication Test Set	HP	8920B	--	Jul. 12, 2019	Jul. 11, 2020
Vector Analyzer	Agilent	E4440A	--	Feb. 27, 2019	Feb. 26, 2020
Attenuator	Weinachel Corp	58-30-33	ML030	Jul. 12, 2019	Jul. 11, 2020

#### 4. SUPPORT EQUIPMENT LIST

Device Type	Manufacturer	Model Name	Serial No.	Data Cable	Power Cable
--	--	--	--	--	--

#### 5. SYSTEM DESCRIPTION

##### EUT test procedure:

1. Connect EUT and peripheral devices.
2. Power on the EUT, the EUT begins to work.
3. Make sure the EUT normal working.

##### EMC TEST MODES

No.	TEST MODES
1	Scanning mode
2	Scanning stopped/Receiving at low channel of 136 MHz -174MHz
3	Scanning stopped/Receiving at middle channel of 136 MHz -174MHz
4	Scanning stopped/Receiving at high channel of 136 MHz -174MHz
5	Scanning stopped/Receiving at low channel of 400 MHz -480 MHz
6	Scanning stopped/Receiving at middle channel of 400 MHz -480 MHz
7	Scanning stopped/Receiving at high channel of 400 MHz -480 MHz

**Note:** Only the result of the worst case was recorded in the report.



## 6. SUMMARY OF TEST RESULTS

FCC Rules	Description Of Test	Result
§15.107	Conduction Emission	Compliant
§15.109	Radiated Emission	Compliant
§15.111	Antenna Conducted Power for receivers	Compliant
§15.121(b)	Scanning receivers and frequency converters used with scanning receivers	Compliant





## 7. FCC RADIATED EMISSION TEST

### 7.1. TEST EQUIPMENT OF RADIATED EMISSION

### 7.2. LIMITS OF RADIATED EMISSION TEST

Frequency (MHz)	Distance (m)	Maximum Field Strength Limit (dBuV/m/ Q.P.)
30~88	3	41.0
88~216	3	45.0
216~960	3	48.0
960~2000	3	53.5

\*\*Note: The lower limit shall apply at the transition frequency. Because the EUT RX frequency range up to 480 MHz, so the upper the frequency range up to 2 GHz.

### 7.3 BLOCK DIAGRAM OF RADIATED EMISSION TEST

RADIATED EMISSION TEST SETUP 30MHz-1000MHz

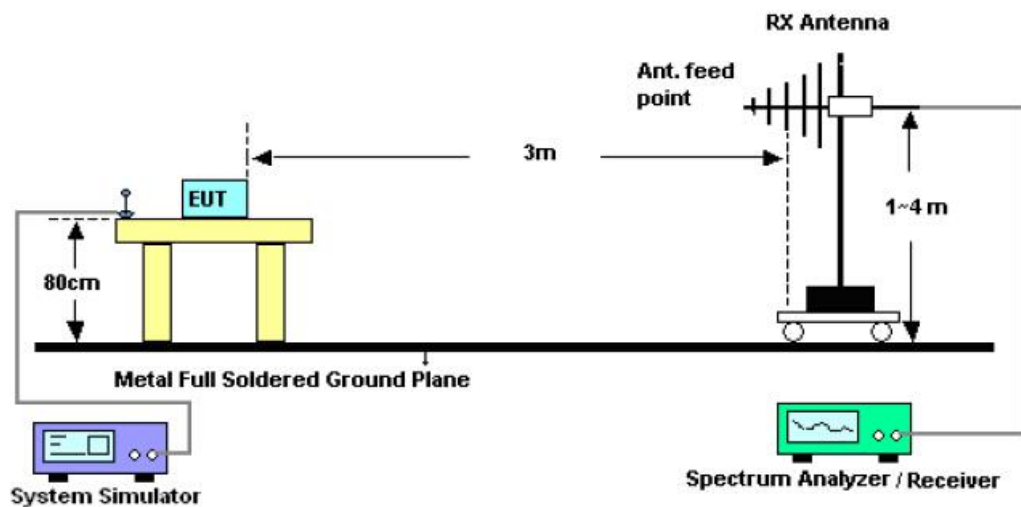

RADIATED EMISSION TEST SETUP ABOVE 1000MHz

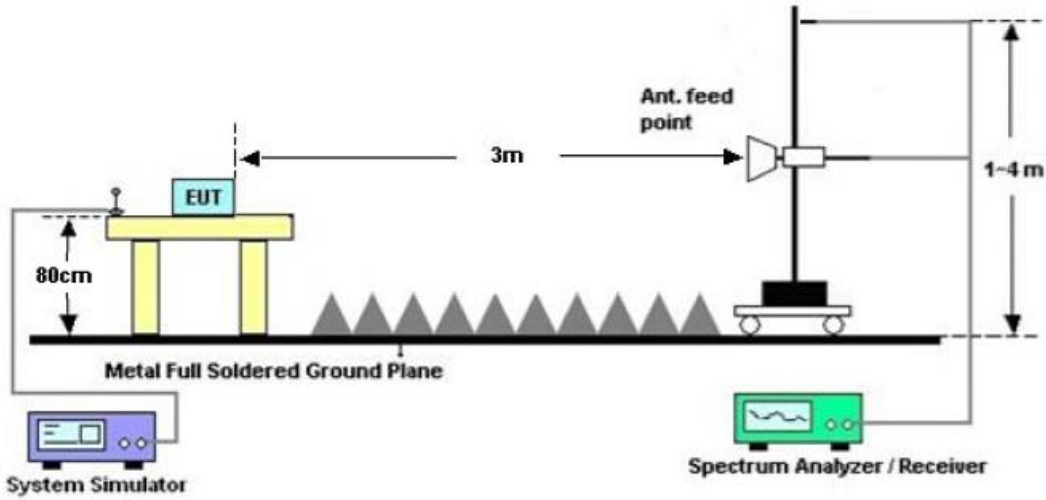

#### 7.4 PROCEDURE OF RADIATED EMISSION TEST

- 1) The equipment was set up as per the test configuration to simulate typical actual usage per the user's manual. When the EUT is a tabletop system, a wooden turntable with a height of 0.8 meters is used which is placed on the ground plane as per ANSI C63.4 (see Test Facility for the dimensions of the ground plane used). When the EUT is floor-standing equipment, it is placed on the ground plane which has a 3-12 mm non-conductive covering to insulate the EUT from the ground plane.
- 2) Support equipment, if needed, was placed as per ANSI C63.4.
- 3) All I/O cables were positioned to simulate typical actual usage as per ANSI C63.4.
- 4) The EUT received power by AC 120V/60Hz.
- 5) The antenna was placed at 3 meter away from the EUT as stated in FCC Part 15. The antenna connected to the Analyzer via a cable and at times a pre-amplifier would be used.
- 6) The Analyzer / Receiver quickly scanned from 30MHz to 1000MHz. The EUT test program was started. Emissions were scanned and measured rotating the EUT to 360 degrees and positioning the antenna 1 to 4 meters above the ground plane, in both the vertical and the horizontal polarization, to maximize the emission reading level.
- 7) The test mode(s) were scanned during the test:
- 8) Recorded at least the six highest emissions. Emission frequency, amplitude, antenna position, polarization and turntable position were recorded into a computer in which correction factors were used to calculate the emission level and compare reading to the applicable limit and Q.P./Peak reading is presented. For emissions below 1GHz, use 120KHz RBW and VBW $\geq$ 3RBW for QP reading.
- 9) For emissions above 1GHz, use 1MHz RBW and 3MHz VBW for peak reading. Then 1MHz RBW and 10Hz VBW for average reading in spectrum analyzer.
- 10) When the radiated emissions limits are expressed in terms of the average value of the emissions, and pulsed operation is employed, the measurement field strength shall be determined by averaging over one complete pulse train, including blanking intervals, as long as the pulse train does not exceed 0.1 seconds. As an alternative (provided the transmitter operates for longer than 0.1 seconds) or in cases where the pulse train exceeds 0.1 seconds, the measured field strength shall be determined from the average absolute voltage during a 0.1 second interval during which the field strength is at its maximum values.
- 11) If the emissions level of the EUT in peak mode was 3 dB lower than the average limit specified, then testing will be stopped and peak values of EUT will be reported, otherwise, the emissions which do not have 3 dB margin will be repeated one by one using the quasi-peak method for below 1GHz.
- 12) For testing above 1GHz, the emissions level of the EUT in peak mode was lower than average limit (that means the emissions level in peak mode also complies with the limit in average mode), then testing will be stopped and peak values of EUT will be reported, otherwise, the emissions will be measured in average mode again and reported.
- 13) In case the emission is lower than 30MHz, loop antenna has to be used for measurement and the recorded data should be QP measured by receiver. High - Low scan is not required in this case.
- 14) The test data of the worst case condition (mode 1) was reported on the following Data page

### 7.5 TEST RESULT OF RADIATED EMISSION TEST

#### Radiated Emission Test –Horizontal -3m Below 1G

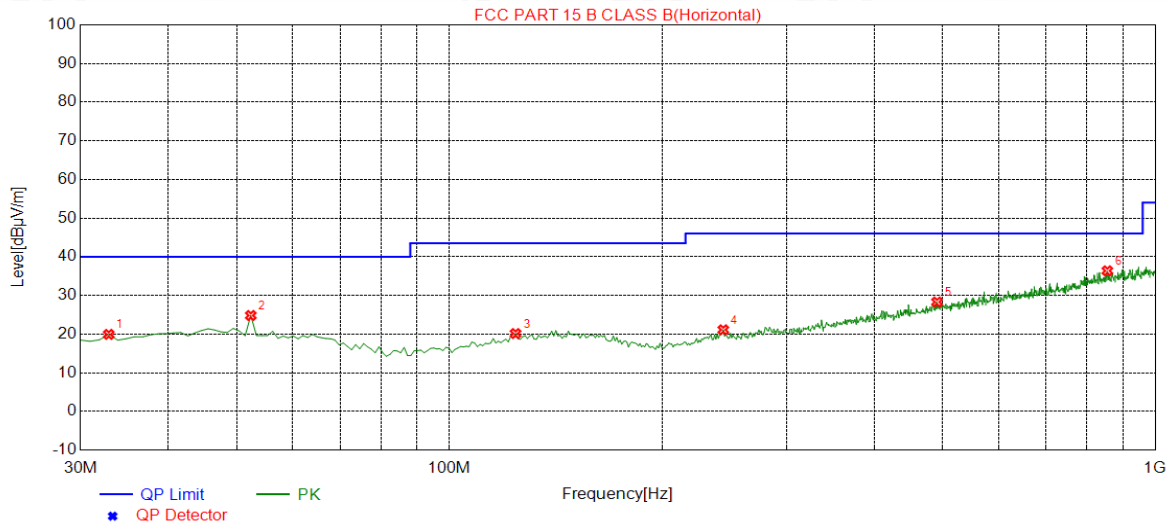

NO.	Freq. [MHz]	Level [dBµV/m]	Factor [dB]	Limit [dBµV/m]	Margin [dB]	Height [cm]	Angle [°]	Polarity
1	32.9100	19.92	13.36	40.00	20.08	100	269	Horizontal
2	52.3100	24.81	14.49	40.00	15.19	100	58	Horizontal
3	124.0900	20.13	13.75	43.50	23.37	100	136	Horizontal
4	244.3700	21.11	14.78	46.00	24.89	100	3	Horizontal
5	490.7500	28.30	21.96	46.00	17.70	100	316	Horizontal
6	855.4700	36.36	29.42	46.00	9.64	100	262	Horizontal

**RESULT: PASS**



Attestation of Global Compliance

Attestation of Global Compliance (Shenzhen) Co., Ltd.  
 Add: 2/F., Building 2, Sanwei Chaxi Industrial Park, Sanwei Community,  
 Hangcheng Street, Bao'an District, Shenzhen, Guangdong, China  
 Tel: +86-755 2523 4088 E-mail: agc@agc-cert.com Service Hotline: 400 089 2118

### Radiated Emission Test –Vertical -3m Below 1G

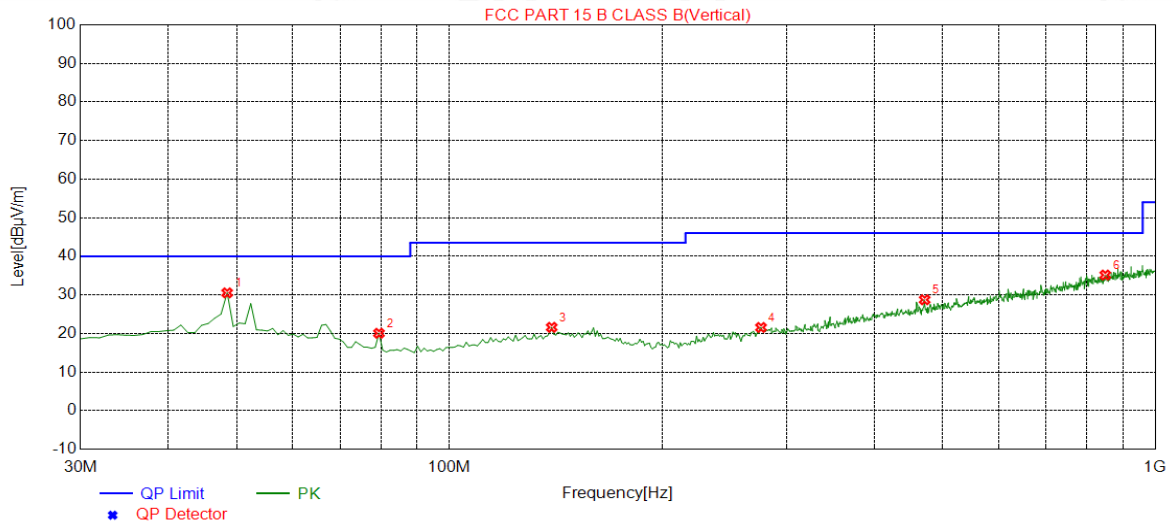

NO.	Freq. [MHz]	Level [dBµV/m]	Factor [dB]	Limit [dBµV/m]	Margin [dB]	Height [cm]	Angle [°]	Polarity
1	48.4300	30.52	14.71	40.00	9.48	100	123	Vertical
2	79.4700	20.04	10.26	40.00	19.96	100	227	Vertical
3	139.6100	21.59	14.85	43.50	21.91	100	30	Vertical
4	276.3800	21.55	15.96	46.00	24.45	100	27	Vertical
5	471.3500	28.73	21.45	46.00	17.27	100	274	Vertical
6	849.6500	35.14	29.30	46.00	10.86	100	130	Vertical

#### RESULT: PASS

- Note:**
1. Factor=Antenna Factor + Cable loss - Amplifier gain, Margin=Measurement-Limit.
  2. The "Factor" value can be calculated automatically by software of measurement system.
  3. Emissions range from 1GHz to 2GHz have 20dB margin. No recording in the test report.
  4. Only the data of the worst case would be record in this test report.



## 8. CONDUCTED EMISSION TEST

### 8.1 PROVISIONS APPLICABLE

For an intentional radiator that is designed to be connected to the public utility (AC) power line, the, the radio frequency voltage that is conducted back onto the AC power line on any frequencies within the band 150 KHz to 30 MHz shall not exceed the limits in the following table, as measured using a 50uH/50 ohms line impedance stabilization network (LISN). Compliance with the provisions of this paragraph shall be based on the measurement of the radio frequency voltage between each power line and ground at the power terminal. The lower limit applies at the boundary between the frequencies ranges.

Frequency of Emission (MHz)	Conducted Limit(dBuV)	
	Quasi-Peak	Average
0.15 – 0.5	66 to 56 *	56 to 46 *
0.5 – 5	56	46
5 – 30	60	50

\* Decreases with the logarithm of the frequency.

### 8.2 MEASUREMENT PROCEDURE

- (1) The equipment was set up as per the test configuration to simulate typical actual usage per the user's manual. When the EUT is a tabletop system, a wooden table with a height of 0.8 meters is used and is placed on the ground plane as per ANSI C63.4 (see Test Facility for the dimensions of the ground plane used). When the EUT is a floor-standing equipment, it is placed on the ground plane which has a 3-12 mm non-conductive covering to insulate the EUT from the ground plane.
- (2) Support equipment, if needed, was placed as per ANSI C63.4.
- (3) All I/O cables were positioned to simulate typical actual usage as per ANSI C63.4.
- (4) The EUT received AC 120V/60Hz power through a Line Impedance Stabilization Network (LISN) which supplied power source and was grounded to the ground plane.
- (5) All support equipments received AC power from a second LISN, if any.
- (6) The EUT test program was started. Emissions were measured on each current carrying line of the EUT using a spectrum Analyzer / Receiver connected to the LISN powering the EUT. The LISN has two monitoring points: Line 1 (Hot Side) and Line 2 (Neutral Side). Two scans were taken: one with Line 1 connected to Analyzer / Receiver and Line 2 connected to a 50 ohm load; the second scan had Line 1 connected to a 50 ohm load and Line 2 connected to the Analyzer / Receiver.
- (7) Analyzer / Receiver scanned from 150 KHz to 30MHz for emissions in each of the test modes.

During the above scans, the emissions were maximized by cable manipulation.



**8.3 TEST SETUP BLOCK DIAGRAM**

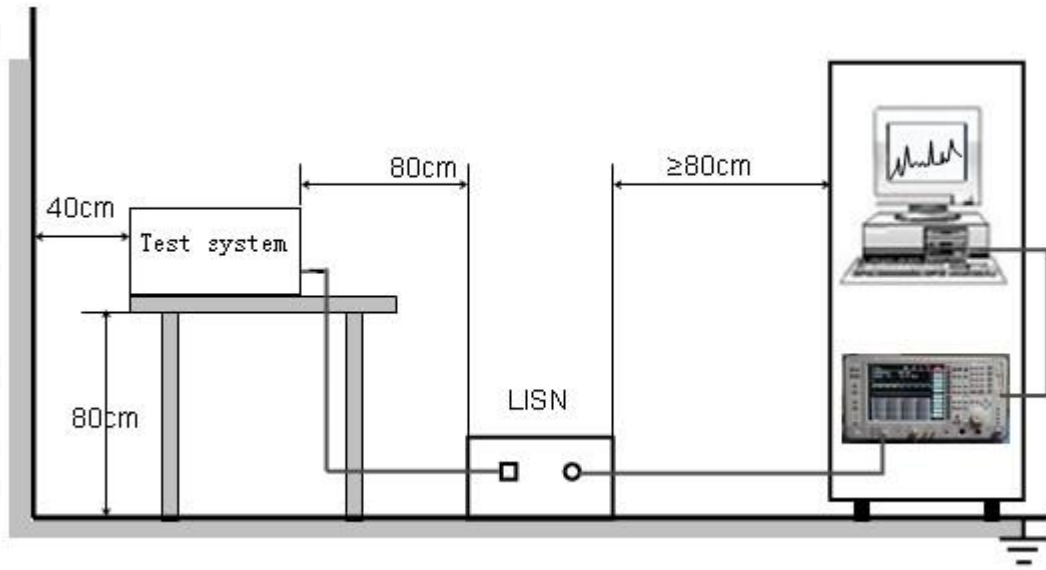

### 8.4 TEST RESULT

#### CONDUCTED EMISSION TEST-L

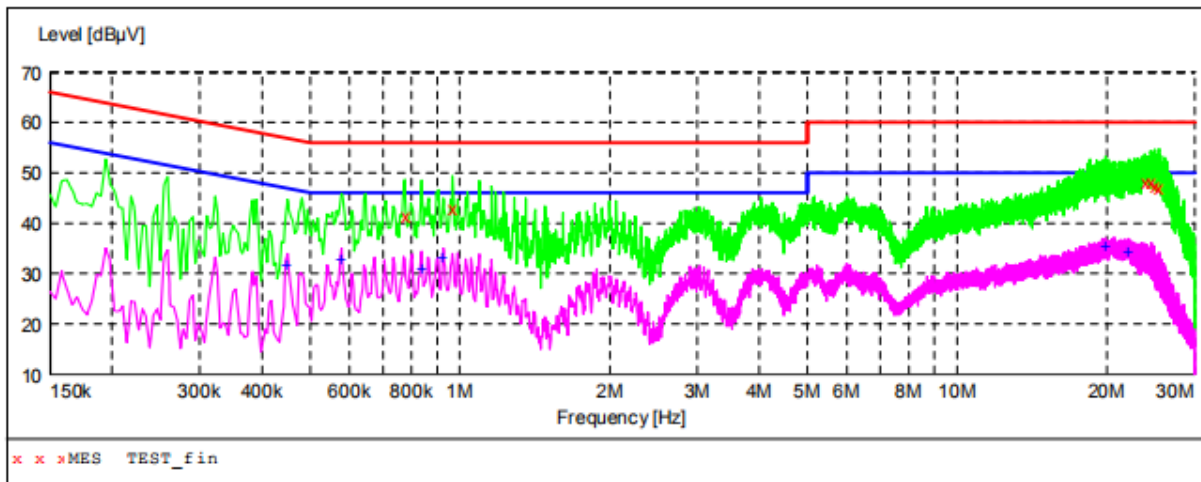

#### MEASUREMENT RESULT: "TEST\_fin"

2019/10/17 20:23

Frequency MHz	Level dBuV	Transd dB	Limit dBuV	Margin dB	Detector	Line	PE
0.774000	41.50	10.5	56	14.5	QP	L1	FLO
0.966000	43.00	11.1	56	13.0	QP	L1	FLO
23.798000	48.00	12.9	60	12.0	QP	L1	FLO
24.566000	48.10	13.0	60	11.9	QP	L1	FLO
24.986000	47.50	13.0	60	12.5	QP	L1	FLO
25.466000	47.10	13.0	60	12.9	QP	L1	FLO

#### MEASUREMENT RESULT: "TEST\_fin2"

2019/10/17 20:23

Frequency MHz	Level dBuV	Transd dB	Limit dBuV	Margin dB	Detector	Line	PE
0.450000	31.70	10.6	47	15.2	AV	L1	FLO
0.578000	33.00	10.7	46	13.0	AV	L1	FLO
0.838000	31.10	10.7	46	14.9	AV	L1	FLO
0.926000	33.40	11.0	46	12.6	AV	L1	FLO
19.866000	35.60	12.6	50	14.4	AV	L1	FLO
22.094000	34.40	12.8	50	15.6	AV	L1	FLO

RESULT: PASS



Attestation of Global Compliance

Attestation of Global Compliance(Shenzhen)Co.,Ltd.

Add: 2/F., Building 2, Sanwei Chaxi Industrial Park, Sanwei Community,  
Hangcheng Street, Bao'an District, Shenzhen, Guangdong, China

Tel: +86-755 2523 4088

E-mail: agc@agc-cert.com

Service Hotline: 400 089 2118



CONDUCTED EMISSION TEST-N

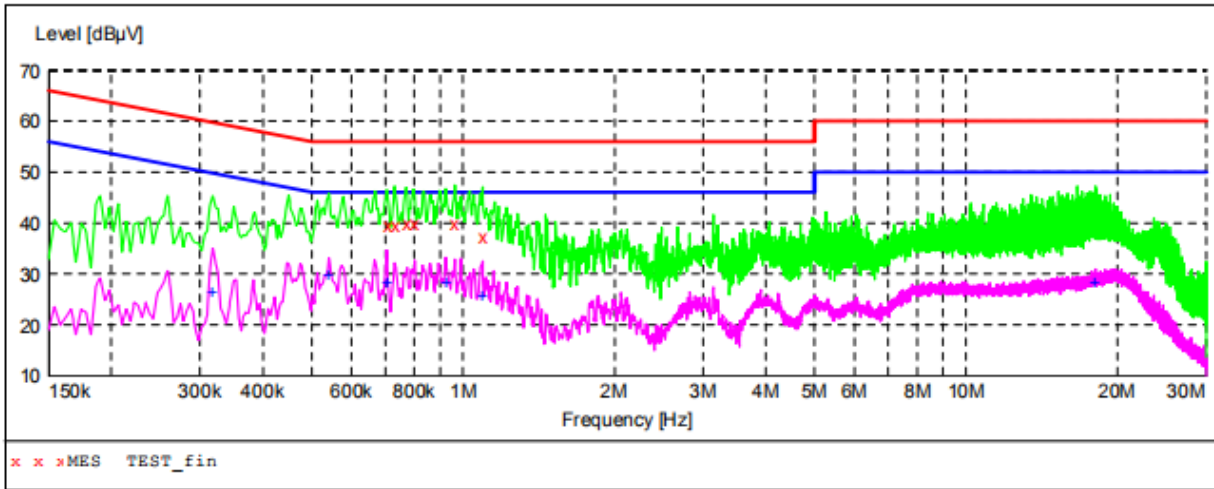

**MEASUREMENT RESULT: "TEST\_fin"**

2019/10/17 20:26

Frequency MHz	Level dBµV	Transd dB	Limit dBµV	Margin dB	Detector	Line	PE
0.706000	39.50	10.2	56	16.5	QP	N	FLO
0.730000	39.60	10.3	56	16.4	QP	N	FLO
0.770000	40.10	10.5	56	15.9	QP	N	FLO
0.798000	40.10	10.6	56	15.9	QP	N	FLO
0.962000	40.00	11.1	56	16.0	QP	N	FLO
1.094000	37.40	11.3	56	18.6	QP	N	FLO

**MEASUREMENT RESULT: "TEST\_fin2"**

2019/10/17 20:26

Frequency MHz	Level dBµV	Transd dB	Limit dBµV	Margin dB	Detector	Line	PE
0.318000	26.60	10.7	50	23.2	AV	N	FLO
0.542000	29.80	10.8	46	16.2	AV	N	FLO
0.706000	28.40	10.2	46	17.6	AV	N	FLO
0.922000	28.50	11.0	46	17.5	AV	N	FLO
1.094000	25.90	11.3	46	20.1	AV	N	FLO
18.082000	28.50	12.5	50	21.5	AV	N	FLO

**RESULT: PASS**



Attestation of Global Compliance

## 9. ANTENNA CONDUCTED POWER FOR RECEIVERS

### LIMIT

The antenna conducted power of the receiver as defined in §15.111 shall not exceed the values given in the following tables

Frequency Range	9 KHz to 2GHz
Limit	2.0 nW (-57 dBm )

### TEST CONFIGURATION

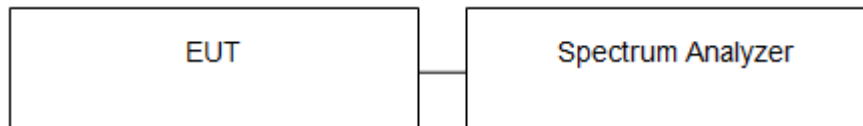

### TEST PROCEDURE

1. The receiver antenna terminal connected to a spectrum analyzer.
2. The test data of the worst case condition (mode 1) was reported on the following Data page.

**TEST RESULTS**

**Conducted Measurement (9 KHz to 150 KHz)**

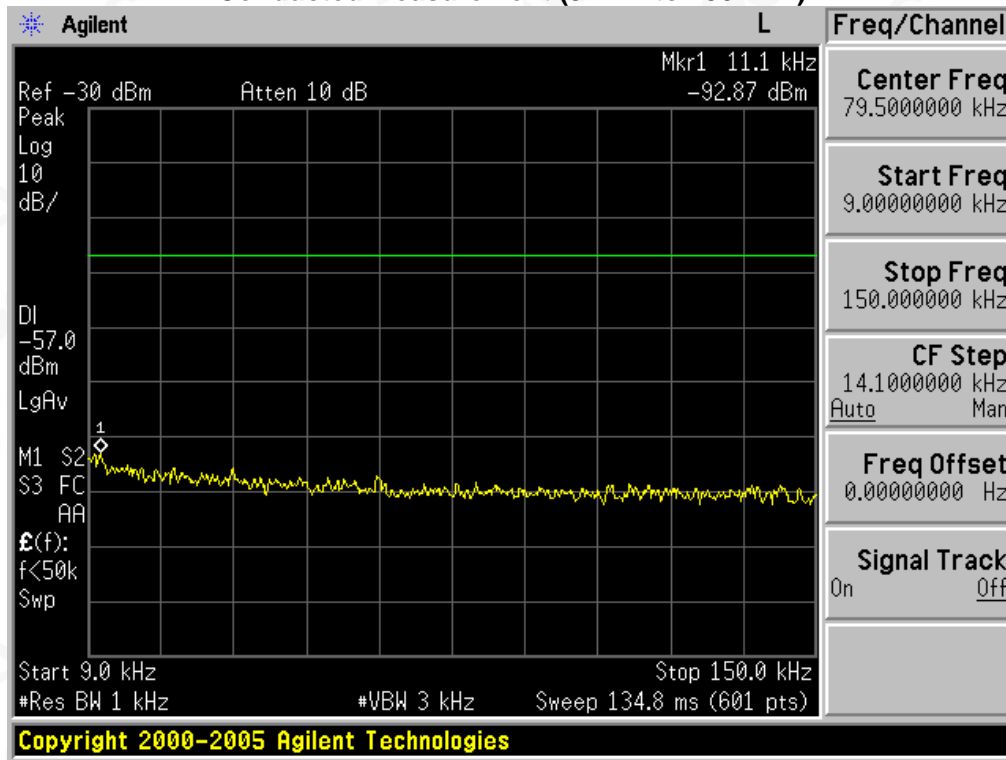

**Conducted Measurement (150 KHz to 30MHz)**

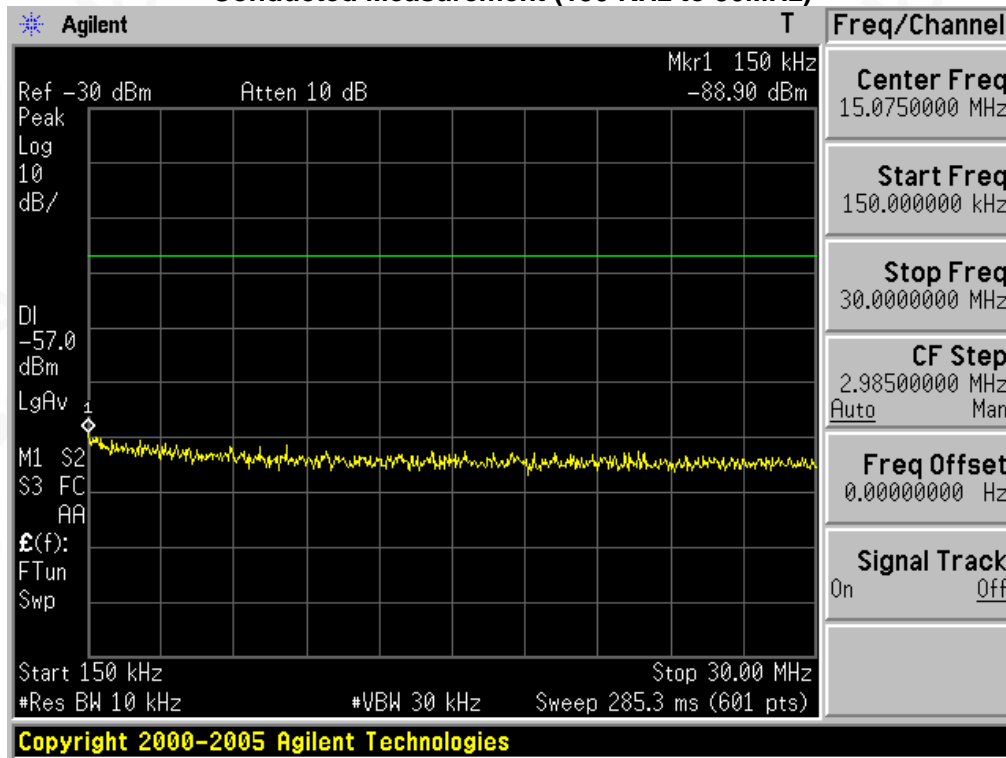

Attestation of Global Compliance

Attestation of Global Compliance(Shenzhen)Co.,Ltd.  
Add: 2/F., Building 2, Sanwei Chaxi Industrial Park, Sanwei Community,  
Hangcheng Street, Bao'an District, Shenzhen, Guangdong, China  
Tel: +86-755 2523 4088 E-mail: agc@agc-cert.com Service Hotline:400 089 2118

### Conducted Measurement (30MHz to 1GHz)

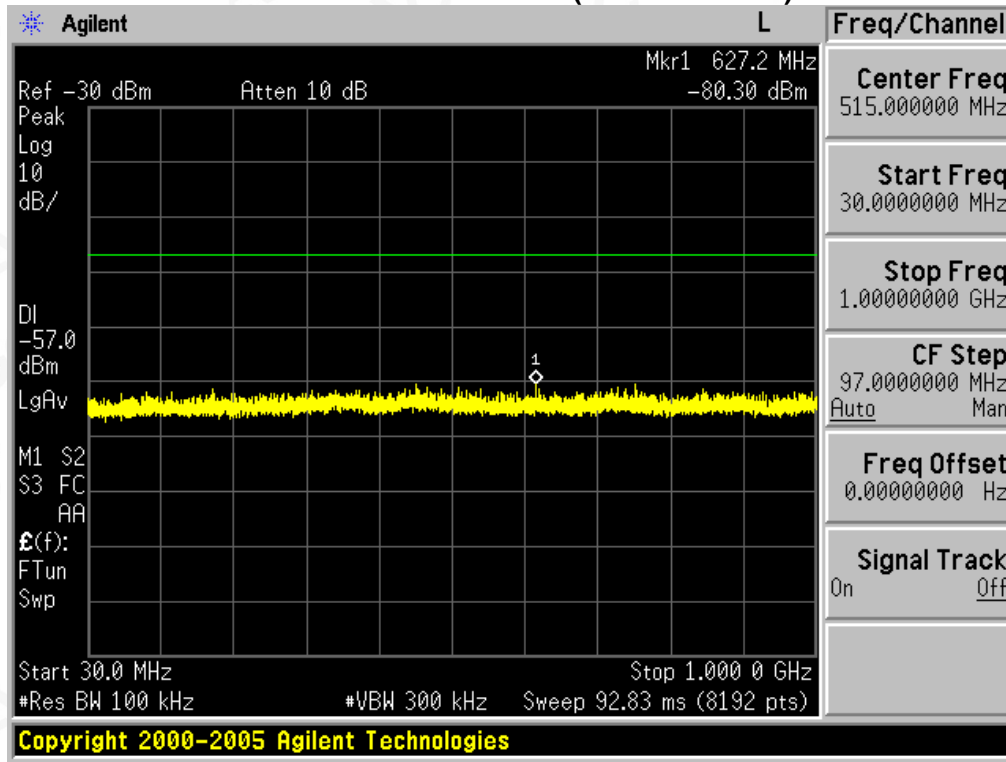

### Conducted Measurement (1GHz to 2GHz)

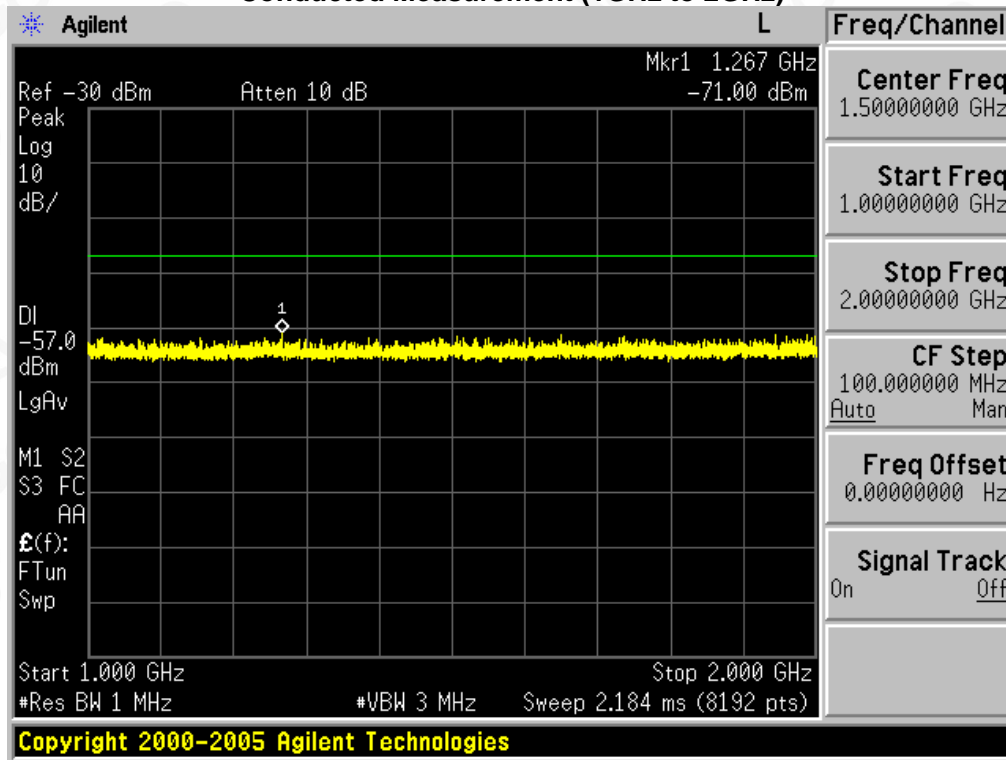

**PASS**



Attestation of Global Compliance

Attestation of Global Compliance(Shenzhen)Co.,Ltd.  
Add: 2/F., Building 2, Sanwei Chaxi Industrial Park, Sanwei Community,  
Hangcheng Street, Bao'an District, Shenzhen, Guangdong, China  
Tel: +86-755 2523 4088 E-mail: agc@agc-cert.com Service Hotline:400 089 2118

## 10. SANNING RECEIVERS AND FREQUENCY CONVERTERS USED WITH SANNING RECEIVERS.

### LIMIT

Except as provided in paragraph (c) of this section, scanning receivers shall reject any signals from the Cellular Radiotelephone Service frequency bands that are 38 dB or lower based upon a 12 dB SINAD measurement, which is considered the threshold where a signal can be clearly discerned from any interference that may be present.

### TEST CONFIGURATION

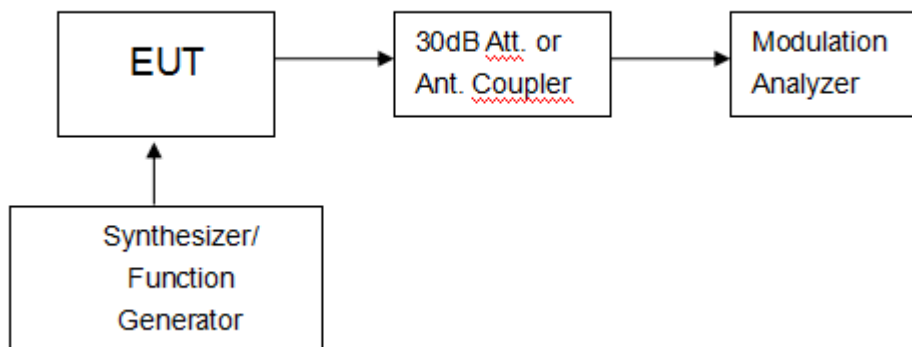

### TEST PROCEDURE

Please review the FCC Part 15.121 b section requirements to meet the testing process

### TEST RESULTS

VHF:

Frequency Range(MHz)	Channel	Measurement Result (dB)	Limit(dB)	Result
136-174	Bottom	41	> 38	Pass
136-174	Middle	45	> 38	Pass
136-174	Top	44	> 38	Pass



**UHF:**

Frequency Range(MHz)	Channel	Measurement Result (dB)	Limit(dB)	Result
400-480	Bottom	45	>38	Pass
400-480	Middle	47	>38	Pass
400-480	Top	45	>38	Pass

- Note:1.This device meets the requirements of FCC PART 15.121.b  
2.The test report only shows the worst test results



### APPENDIX 1 PHOTOGRAPHS OF TEST SETUP CONDUCTED EMISSION TEST SETUP



RADIATED EMISSION TEST SETUP-BELOW 1GHZ

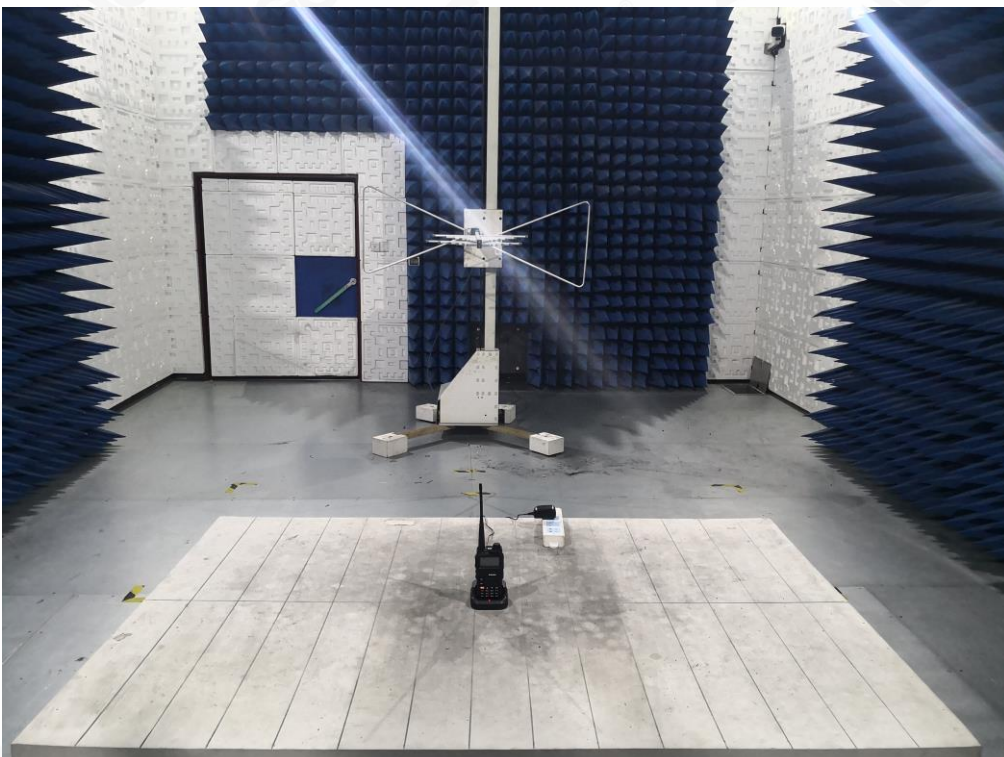

**RADIATED EMISSION TEST SETUP-ABOVE 1GHZ**

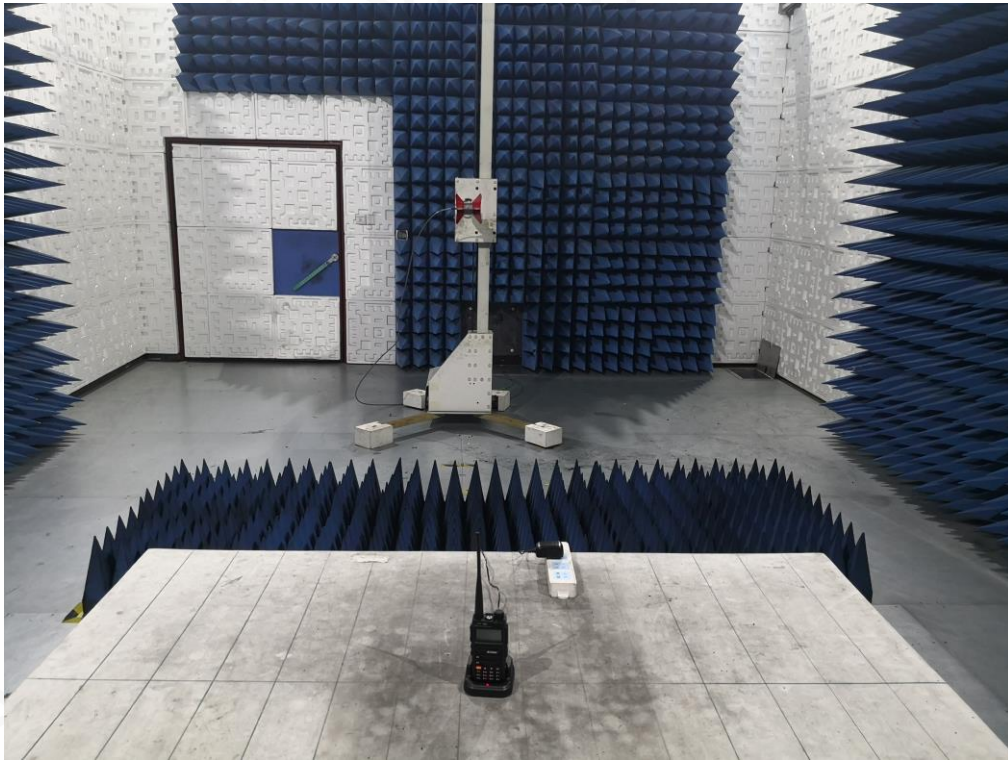



**APPENDIX 2 PHOTOGRAPHS OF EUT**

TOTAL VIEW OF EUT



TOP VIEW OF EUT



**BOTTOM VIEW OF EUT**



**FRONT VIEW OF EUT**



BACK VIEW OF EUT



LEFT VIEW OF EUT



RIGHT VIEW OF EUT



OPEN VIEW-1 OF EUT



OPEN VIEW-2 OF EUT



OPEN VIEW-3 OF EUT

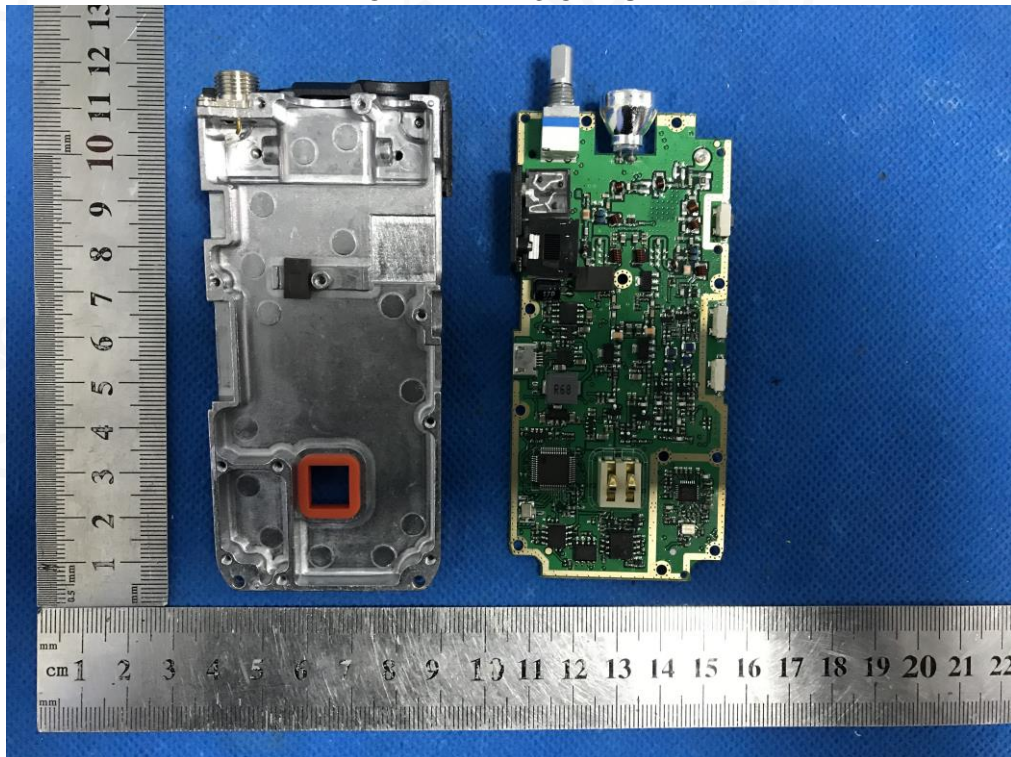

INTERNAL VIEW OF EUT(FIGURE 1)

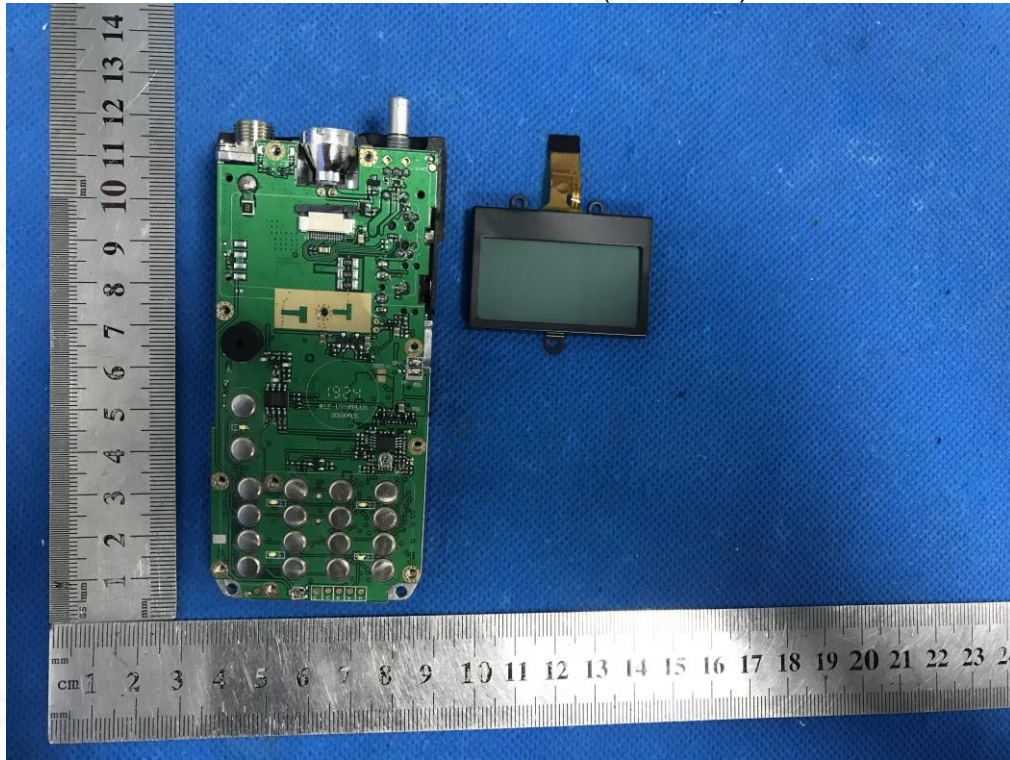

INTERNAL VIEW OF EUT(FIGURE 2)

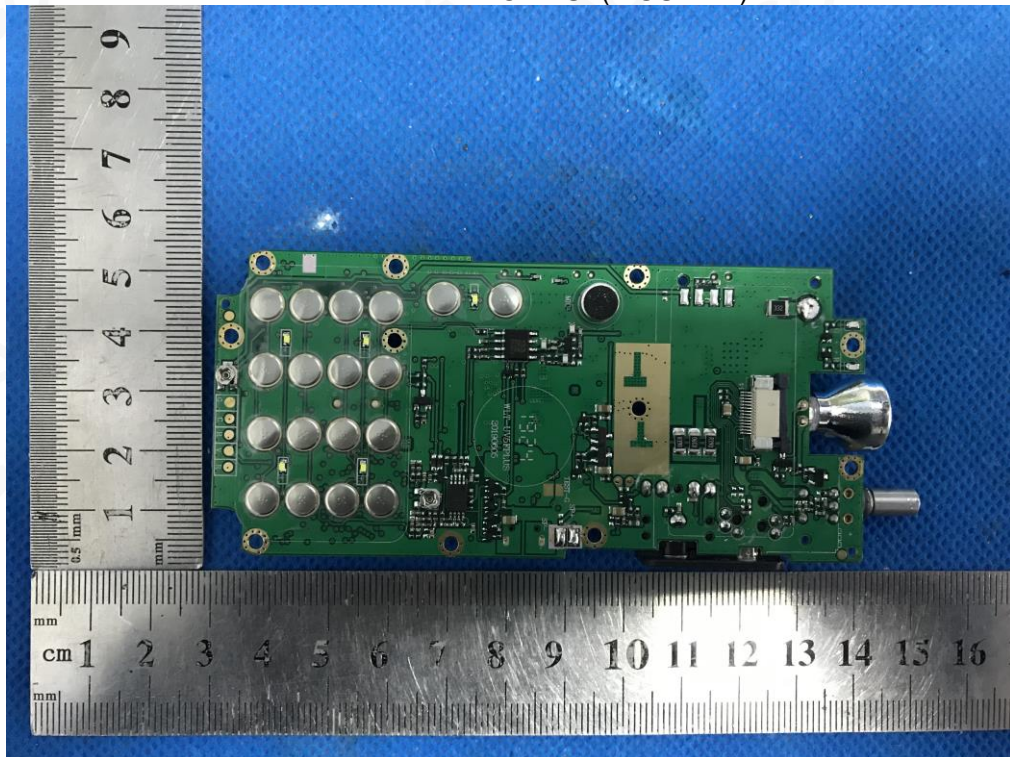

INTERNAL VIEW OF EUT(FIGURE 3)

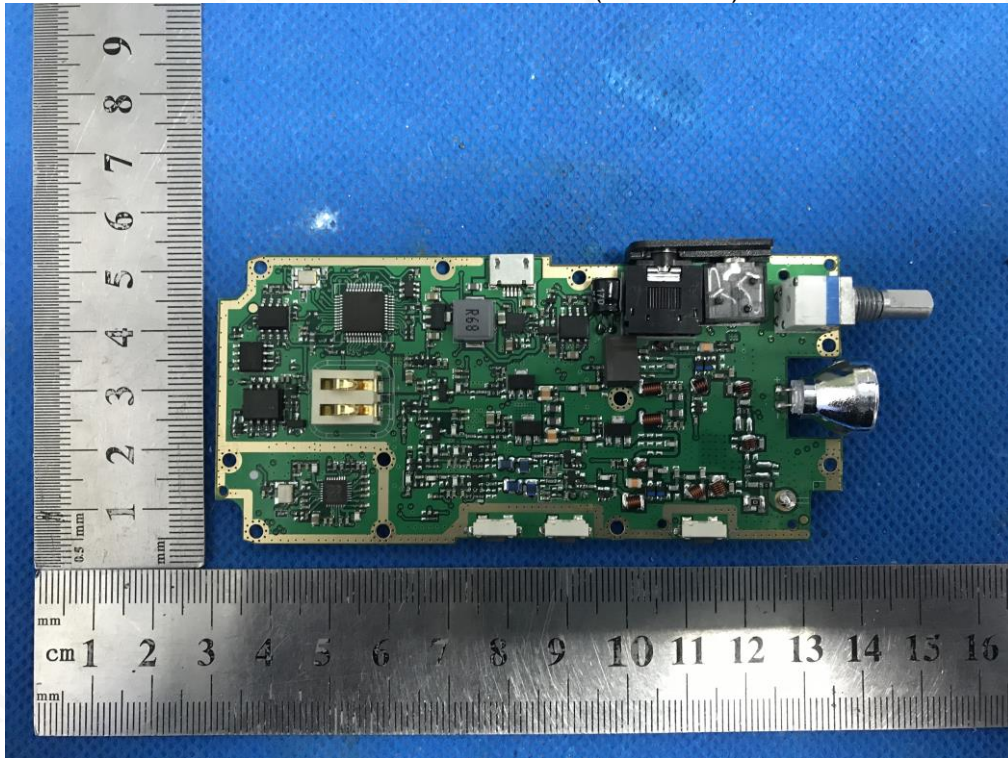

INTERNAL VIEW OF EUT(FIGURE 6)

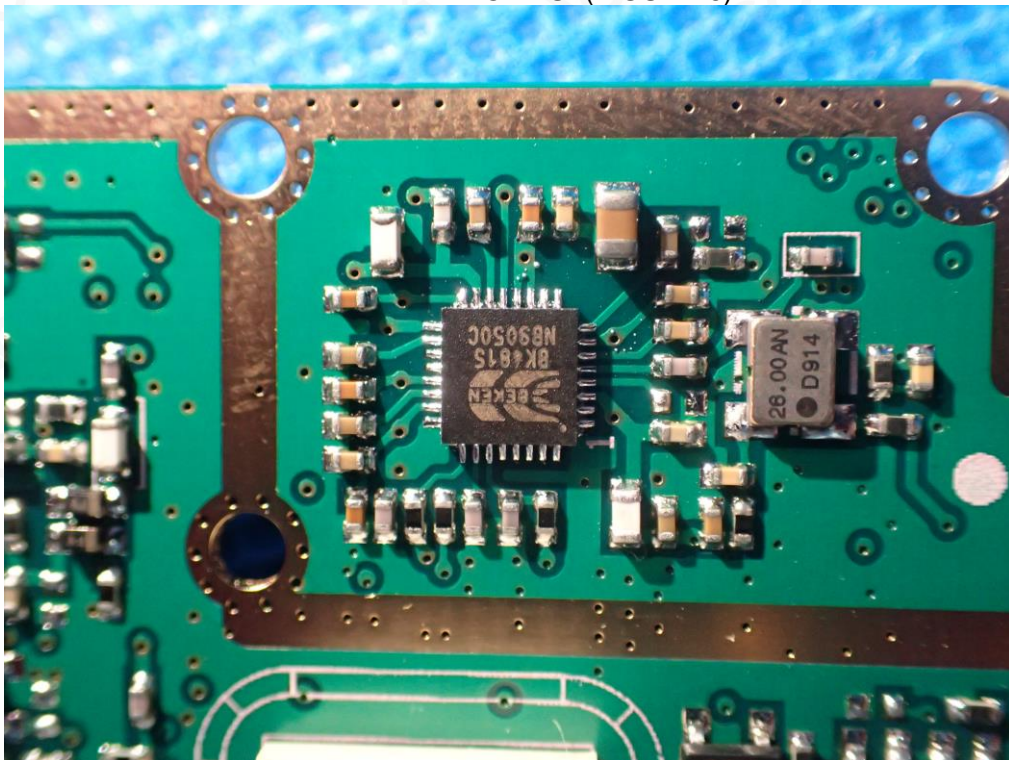

INTERNAL VIEW OF EUT(FIGURE 7)

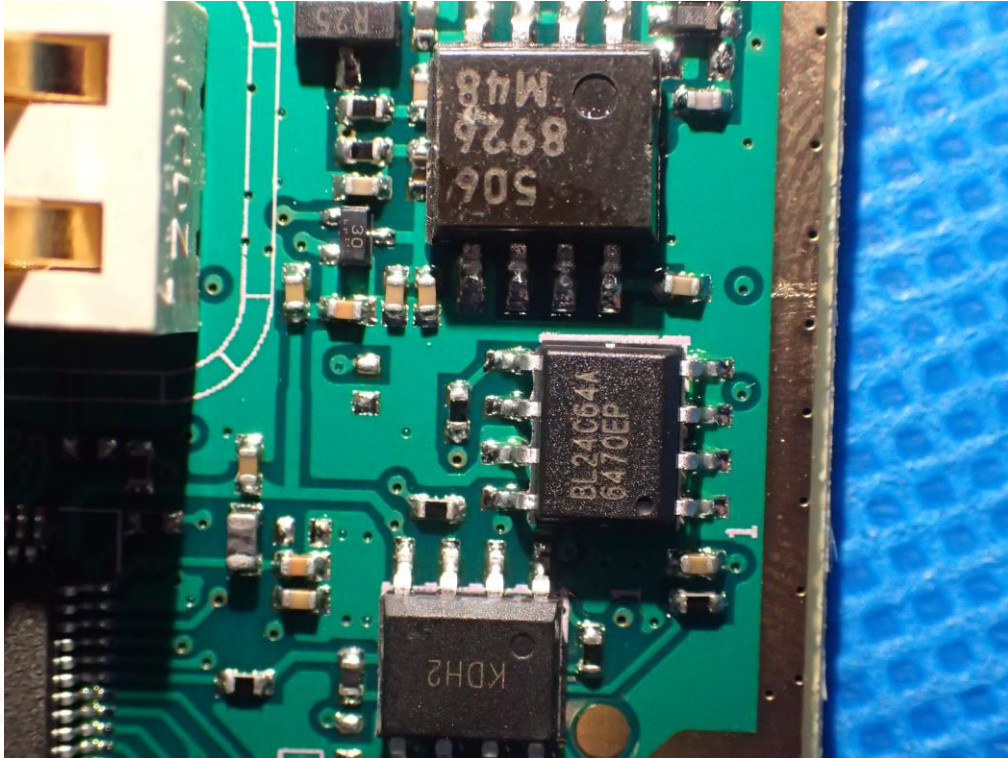

INTERNAL VIEW OF EUT(FIGURE 8)

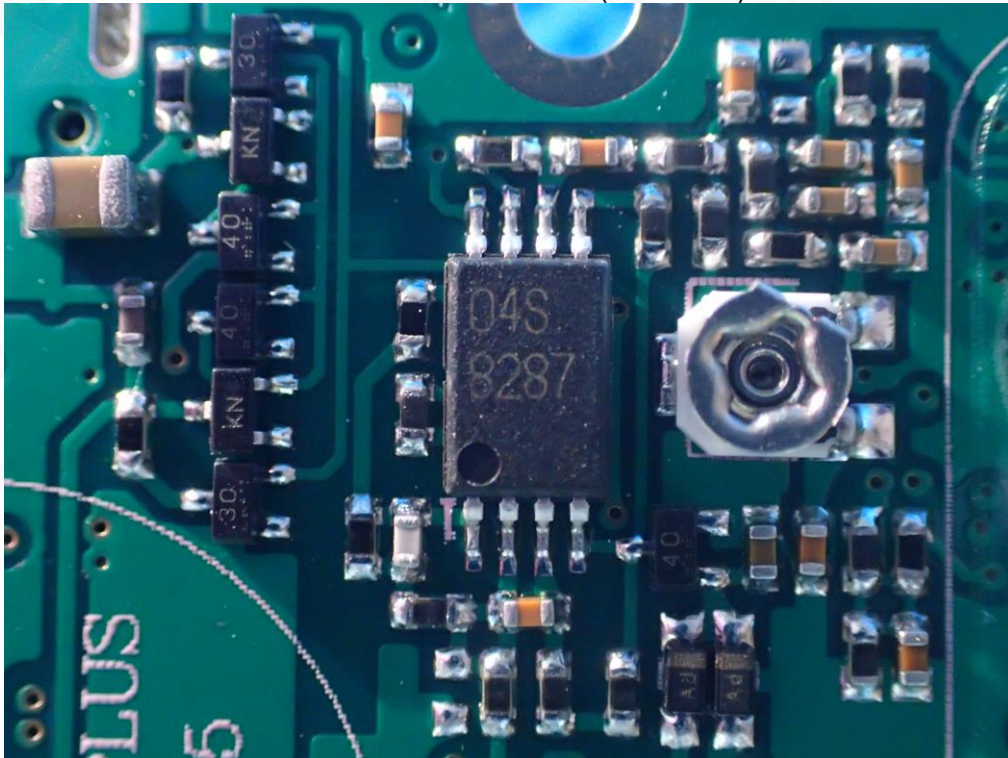



INTERNAL VIEW OF EUT(FIGURE 9)

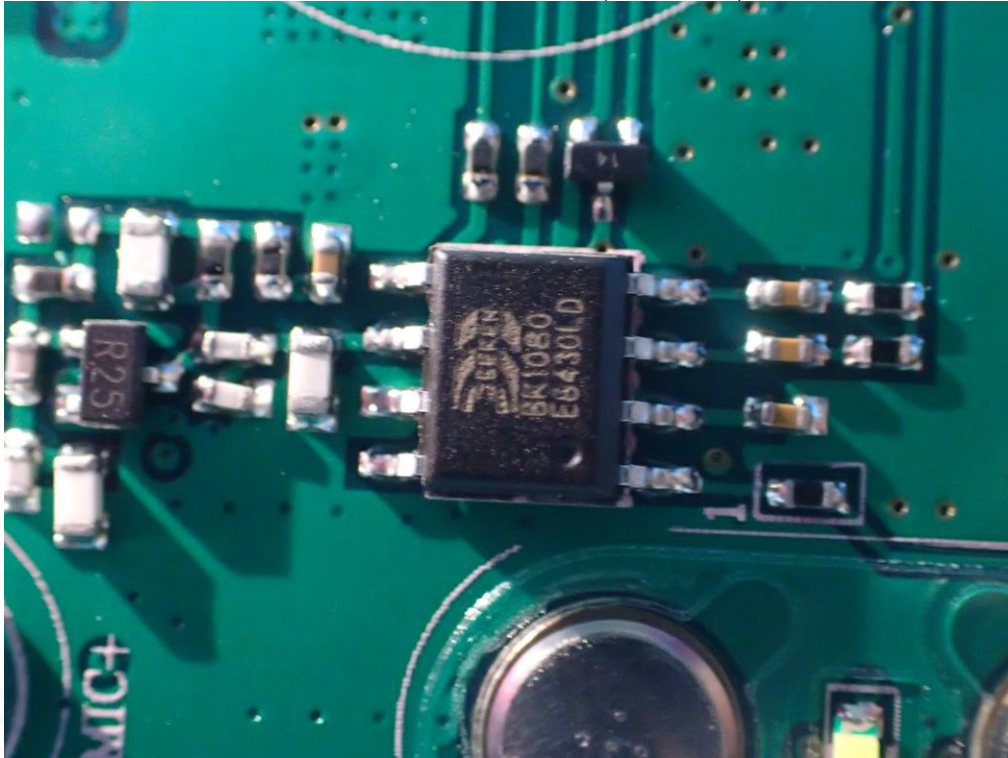

----END OF REPORT----

