

### **FCC Radiation Exposure Statement:**

This equipment complies with FCC radiation exposure limits set forth for an uncontrolled environment. This equipment should be installed and operated with minimum distance 20cm between the radiator & your body.

### **FCC Warning**

This device complies with Part 15 of the FCC Rules. Operation is subject to the following two conditions:

(1) This device may not cause harmful interference, and (2) this device must accept any interference received, including interference that may cause undesired operation.

NOTE 1: This equipment has been tested and found to comply with the limits for a Class B digital device, pursuant to part 15 of the FCC Rules. These limits are designed to provide reasonable protection against harmful interference in a residential installation. This equipment generates uses and can radiate radio frequency energy and, if not installed and used in accordance with the instructions, may cause harmful interference to radio communications. However, there is no guarantee that interference will not occur in a particular installation. If this equipment does cause harmful interference to radio or television reception, which can be determined by turning the equipment off and on, the user is encouraged to try to correct the interference by one or more of the following measures:

- Reorient or relocate the receiving antenna.
- Increase the separation between the equipment and receiver.
- Connect the equipment into an outlet on a circuit different from that to which the receiver is connected.
- Consult the dealer or an experienced radio/TV technician for help.

NOTE 2: Any changes or modifications to this unit not expressly approved by the party responsible for compliance could void the user's authority to operate the equipment.



## Uface 8

( OS-M385C2-V-R23WFC )



## Dear customer,

Thank you for using our product. For better use, please carefully read this instruction. If you have any issues not mentioned here, please contact the provider. All parts of this booklet are reserved by our company, including words, pictures and graphics. Without written permission, no unit or individual shall extract, copy, translate or edit the content in this instruction.

## Device introduction

Parts list

Dimensional drawing

Platform/Software

Operating Instruction

Appearance description

## Installation

Illumination intensity

Position

Height

Steps

Wiring connection

## Product description

Features

FAQ

## Product warranty

Warranty description

## Parts list

No.	Name	Quantity
1	Host	1
2	Power adapter-Desttop-style-Europe Standard	1
3	Hexagon wrench-Ball head-2.5mm-2.5*20*120mm-Ni plated	1
4	Installation sticker-250*116mm-adhesive sticker	1
5	Screws-Cross flat hat self tapping M4X30-Zinc plated	4
6	Expansion pipes-M6X30-Yellow	4
7	Certificate	1
8	User manul	1

## Dimensional Drawing

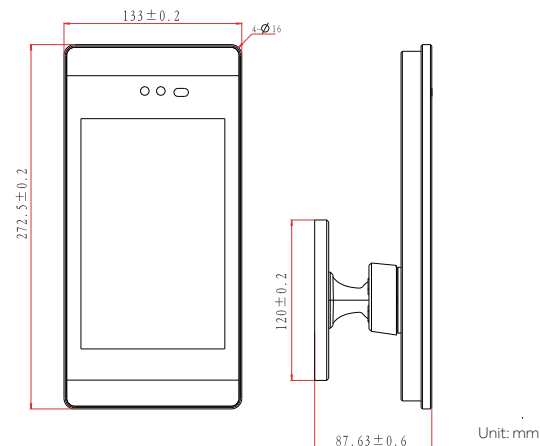

## Operating Instruction

1 / 2

The software carried by the product divides into 2 versions: WO (Wotu platform, provides, provides the secondary development) and LAN (LAN or offline version, provides the secondary development). Please mark the need for software version when place the order. Please contact the customer service for another version if required. For more detailed platform/software instruction manual, please login into the official website to download or contact the customer services.

## Appearance description

### Instruction

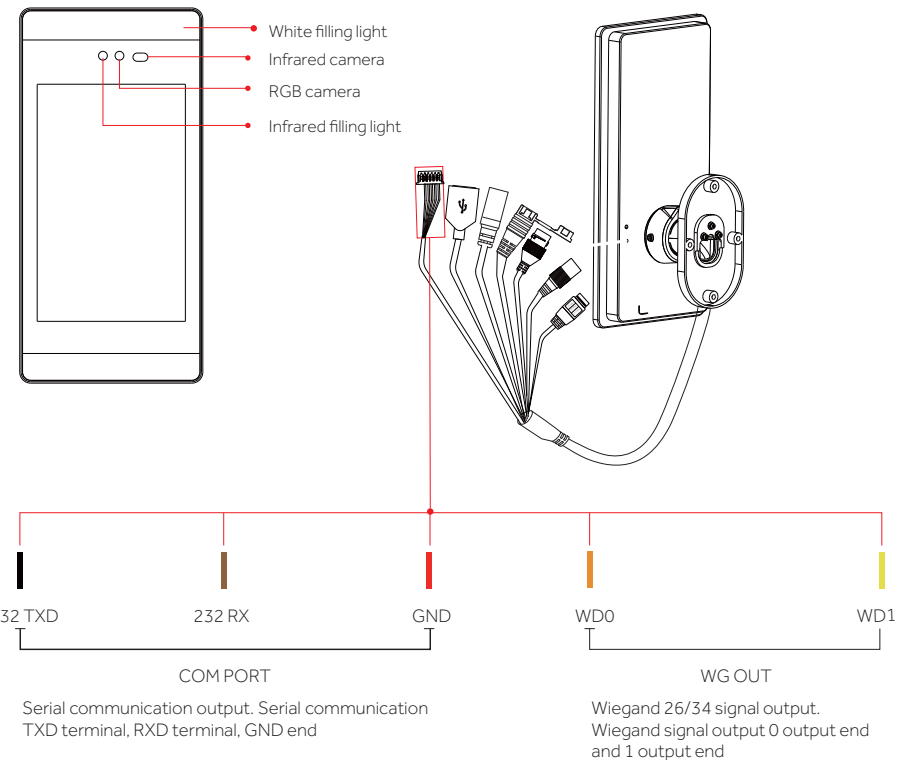

(Pictures for reference only, subject to our products)

### Interface instruction

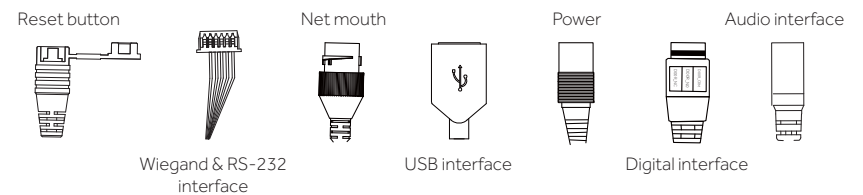

## Illumination intensity

The recognized face, of which, the illumination intensity ("intensity" in short) shall not be lower than 30 Lux. The device has filling light itself, so when the device put in a totally dark environment, the face illumination intensity, 0.5m distance to the device, is about 100 Lux. The nearer to the device, the higher the intensity is. If there is overexposure on the face, the face characteristics will be unable to be extracted and may lead to hard recognition.

### Intensity test

The test standard is as shown on the picture: the angle between dotted line A and dotted line B is 90°, the test adopts the common light meter with full spectrum, and applies U30 standard light source, adjust the distance between source light and test object, subject to the illumination intensity of the object face at this time.

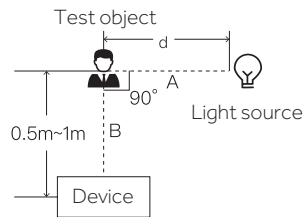

### Reference to intensity



30 Lux, dim      50 Lux, normal



100 Lux, bright      300 Lux, slight exposure      500 Lux, overexposure

## Illumination intensity in actual scenarios

Light issues may lead to big differences between site image and registered image; backlight, side-light and strong light will influence the recognition experience. (Analysis: from the view of human eyes, the color changes on face skin may result in wrong recognition of identity; unclear exposure area, no matter large or small, may result the identity judgement.)

**Side light**

Light source is near to the object      Side-light may lead to uneven light on the face

**Strong light**

Device stands between the light source and object      Direct strong light may cause overexposure

**Back light**

Object stands between the device and light source      Backlight may make the face too dark

**Improvements**

1. Install the device in a place with little impact from light source.
2. Add a registered image according to the site condition, and it is suggested to use this product to enroll images.
3. Properly lower the threshold value according to usage.

## Position

Device shall be installed in places avoiding backlight, side-light and strong light.

	This place, 3m away from the window, or does not influenced by sunlight, can be considered for installation.		Person		Light
	Backlight, side-light or direct strong light, not suitable for installation.		Curtain		Door
	Other areas, install in suitable places according to actual light impact.		Glass window (same as the semi-outdoor scene with no walls)		

<p><b>Sunlight shines indoor</b></p> <p>When the sunlight shines indoor through the window, the face recognition terminal device shall not be installed in shown black shadow area, instead, shall be installed in place with little sunlight impact, no side-light and no backlight. (Glass window can be deemed as no walls)</p>	<p><b>Glass window</b></p> <p>If the room has glass wall, there is no shield for sunlight, then it is suggested to hang curtains over the window, and install the device in place with shield to avoid direct sunlight influencing the recognition. (Glass window can be deemed as no walls)</p>
<p><b>Sunlight shines through the door, with glass window at one side</b></p> <p>Sunlight shines through the door, the device shall be installed at the place with shields and little light impact. Glass window can be deemed as no shields, the device shall be installed at the side without glass window or with curtain hung.</p>	<p><b>Sunlight shines through the door</b></p> <p>Sunlight shines through the door, the device shall be installed at the place with shields and little light impact.</p>

## Height

<p>Camera vertical wide-angle</p>	<p>Camera horizontal wide-angle</p>
-----------------------------------	-------------------------------------

Suggested installation height (distance between the screen and the ground) is 1.4m, as the recognizable body height range, 0.5m distance away from the device, is 1.3m-1.7m; the recognizable body height range, 1m distance away from the device, is 1m-2m. (There are some deviations)

- 1 Paste hole papers, and keep the horizontal line parallel with the ground and the red line 1.25m distance to the ground. Drill 4 screw holes on the wall according to the reminder of hole paper, drill 1 outlet hole according to wiring need. If the wall is hard foundation, use expansion pipe in the parts to knock into the hole.

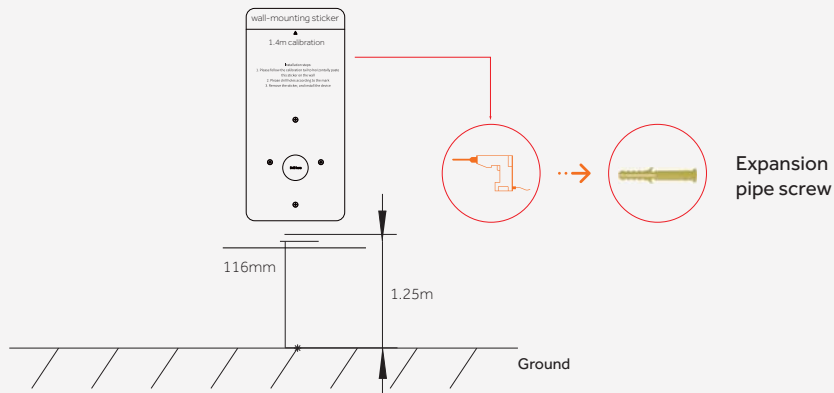

- 2 Move the support (device) to align the 4 holes on it with holes on the wall, and use the screws to fix the support (device) on the wall.

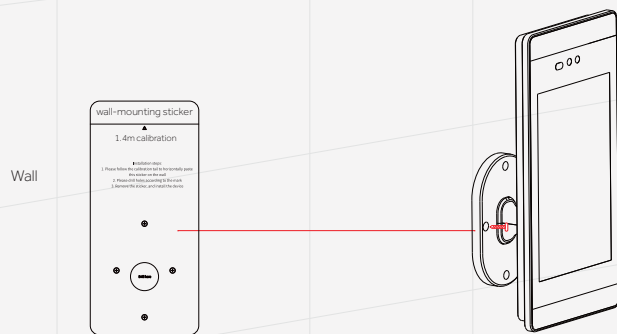

- 1 Attention: If the wall has hard foundation, self-tapping screws shall be used together with expansion pipe; if the wall has soft foundation, use self-tapping screws directly.

- 3 Fix the device, manually adjust device angle to reach the optimal recognition angle.

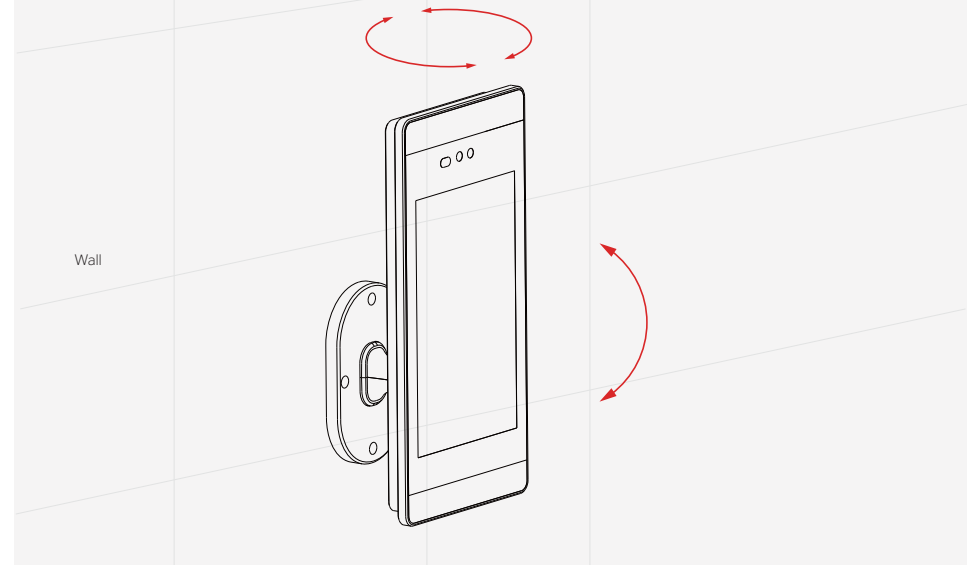

- 4 Wiring instruction.

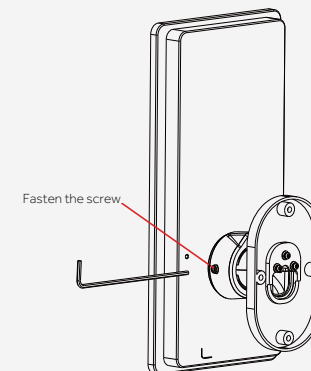

#### Installation steps:

1. Choose suitable position, paste sticker according to needs;
2. Drill holes and place plastic expansion pipes according to installation requirements;
3. Connect device tails with power and net cables;
4. Install the device to plastic expansion pipes;
5. Check if screws are fastened.

Wiring for magnetic door

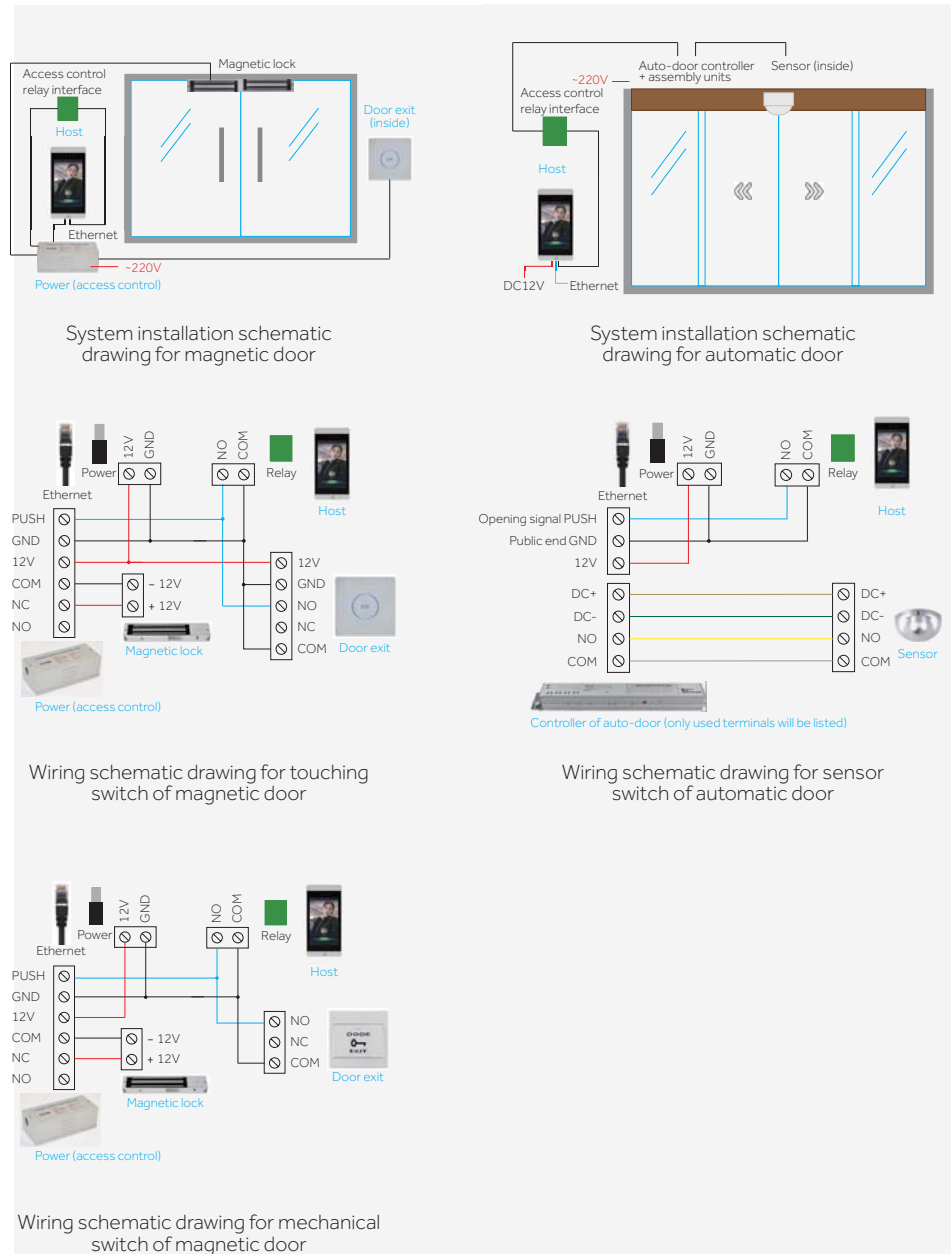

Wiring for automatic door

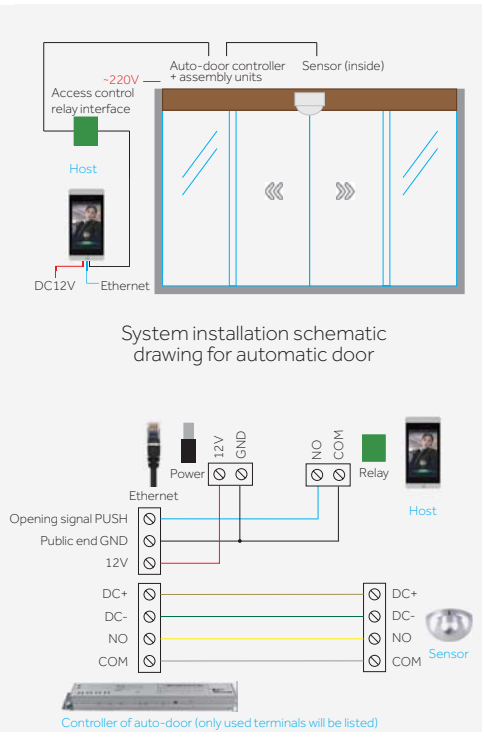

Installation notes

1. When arrange the wires, if the 12V power supply cable of the host does not adopt the "Special power strip" and is in long distance, resulting in large resistance, then abnormal phenomena may occur easily such as insufficient voltage ( $\leq 11V$ ), repeat restart, system crash and so on. Wiring connection of voltage metering is shown as follow.

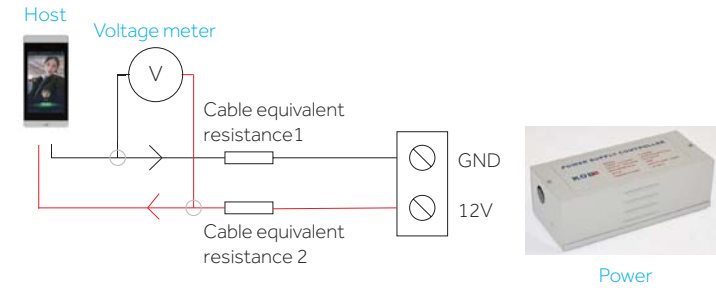

2. Power adapter (brought with the device) of different countries are optional, such as European standard, American standard, British standard and so on.

- Extension of power cable (weak current) cannot exceed 2m, otherwise, it may cause insufficient power supply for the host end, and abnormal phenomena like repeat restart, system crash may occur. If the power is far away from the device, the power cable can be extended (strong current).
- If use other power adapter, 9V 1A as an example, then insufficient voltage and too weak current may cause repeat restart.
- The cable cannot be too fine (such as network cable and fine line), it is suggested to connect multi-strand cable in parallel or use copper core bold cable, to ensure voltage  $> 11V$ .
  - ⓘ Attention: If use network cable, the extension cable use 4-strand cable as positive pole and 4-strand cable as negative pole.
- If not clear with how to extend, please contact the provider to change "Special power strip".

## • Characteristics

Completely resolve image frauds in all kinds of carriers with infrared and RGB dual-camera dynamic anti-forgery; the recognition accuracy is 99.99% (99.77% recognition rate under 1% false accept rate; 99.27% recognition rate under 0.1% false accept rate).

## • Store 100-thousand level database in local

(a) Device using cloud platform supports storing 100 thousand pieces of face images (smaller than 400KB), 1 million pieces of recognition records (0.45KB) and about 100 thousand pieces of on-site capture images; (b) Device using LAN support storing 100 thousand pieces of face images (each image by 100KB) and 1 million pieces of recognition records (including the latest 10 thousand pieces of on-site capture images)

## • Quick recognition speed

(a) Face tracking and detection takes around 20ms; (b) Extracting face feature takes around 250ms; (c) Face comparison takes around 1ms (with 10000 face database)

## • Secondary development (integrated)

Support the interface connection in HTTP; supports 232 serial output, Wiegand 26 and 34 output, custom the configuration of output content.

## • Complete functions

Supports recognition distance configuration; supports stranger detection, and the stranger level can be configured; supports saving the on-site images of face recognition and stranger detection.

## • High extensibility

Supports deployment methods like public network and LAN; supports screen display content configuration.

## • Try to restart and reset

When the device stops in some interface for a long time, users can plug out the power switch, power-on reset and then restart. If it does not take effect, then can long press RESET button for 8-12s to restart the device. Besides, users can contact our staff and make some feedback.

## • Dustproof & Waterproof

This device possesses the protection grade of IP65.

## • Drop resistance

Please avoid operations such as falling, breaking, bending, heavily pressing and so on.

## • Cleaning

Please use soft cloth or such materials, lightly wipe the display screen or panel, and to avoid scrubbing with water and cleaner.

## • Low-temperature environment

The normal working temperature for this device is -10 C ~50 C, if the actual temperature exceeds this range, that may influence the normal use of the device.



Do not dirty or damage the display screen with oil-water or sharp objects



Do not use unknown power adapter to avoid burning out the device

## Dear customer,

Thank you for purchasing and using this product. To better guarantee your satisfaction, please carefully read this warranty clauses after purchase.

### 1. Warranty service

If the device, following the user manual and operating instruction, still breaks down, contact after-sales staff at once, as they will judge the cause on basis of customer description and give remote guidance; if the guidance does not work, then the customer can send back the device for maintenance and test; if the device are unable to be sent back, contact after-sales staff in advance and ask them to head for the site to do the field maintenance. However, if the device problem is found not resulted by hardware or software system of our company after the field maintenance, then customer shall pay the extra fee incurred by the onsite service.

### 2. Instruction

There is a piece of product booklet inside the device package, and customer can contact after-sales staff and ask for installation guidance.

### 3. Warranty period

The product carries a 1-year guarantee period since the delivery date.

### 4. Warranty scope

Device breakdown caused by following conditions is not included within the warranty scope:

- Any damages caused by incorrect use, maintenance or storage, as not follow the user manual;
- Damages caused by falling, water intaking, improper storage or any other man-mad malicious damages;
- Malfunction caused by force majeure such as natural disasters and external causes such as abnormal voltage;
- Damages caused by shipment, please contact the department of transportation;
- Malfunction or damages caused by unfavorable operating environment, such as too high or too low temperature, poor condition, abnormal power system and so on;
- Parts (power adapter, cables, screws) are not within the warranty scope. If parts are lost or damaged, please contact our staff to purchase.

### 5. Maintenance period

When receive the product to be repaired, after-sales staff shall complete the maintenance and send it back within 5 working days. Further communication can be carried out if there are special circumstances.

### 6. Supplemental instruction

- Product damages, caused by natural disasters, external factors or improper operations, are not included within warranty scope. Our company will make the final judgement of whether the damage is caused by above mentioned terms. Users open the product secretly without permission, and cause certain damage, which is also not included within replacement or warranty scope.
- If the device expires the warranty period or not meets the warranty conditions, users may pay for the maintenance cost and shipping cost.
- If the device is sent back without communication, it will not be maintained or repaired normally or will not be refunded, damages caused by this issue will not be compensated.