

OPERATING INSTRUCTIONS

HST-MV3 charging station



HST-MV3-02
HST-MV3-04
HST-MV3-04W

Publication date: February 2018
PC software 2.0.2.25 and higher
Firmware: V-1.0.1.5 and higher

Table of Contents

| | | | |
|-------------|-----------|------------------------------------|--|
| PAGE | 6 | 1 GENERAL INFORMATION | |
| | | 1.1 | Importance of the operating instructions 6 |
| | | 1.2 | Proper Intended Use 6 |
| | | 1.3 | Improper use 7 |
| | | 1.4 | FCC compliance 7 |
| | | 1.5 | Guarantee and liability 7 |
| | | 1.6 | Copyright 8 |
| PAGE | 9 | 2 BASIC SAFETY INSTRUCTIONS | |
| | | 2.1 | Notices in the operating instructions 9 |
| | | 2.2 | Operator's responsibility 9 |
| | | 2.2.1 | Personnel's responsibility 9 |
| | | 2.2.2 | Personnel training 9 |
| | | 2.3 | Risks when working with the charging station 9 |
| | | 2.4 | Danger from electrical energy 10 |
| | | 2.4.1 | Workplace safety 11 |
| | | 2.4.2 | Electrical safety 11 |
| | | 2.4.3 | Service 12 |
| | | 2.5 | Lithium-ion battery 12 |
| | | 2.6 | Cleaning 14 |
| | | 2.7 | Set-up 14 |
| | | 2.8 | Power supply 14 |
| PAGE | 15 | 3 COMMISSIONING | |
| | | 3.1 | Benefits 15 |
| | | 3.2 | Additional information 16 |
| | | 3.2.1 | Charging process 17 |
| | | 3.2.2 | Explanation of the light signals/functions 18 |
| | | 3.2.3 | Sleep function 19 |
| | | 3.3 | Safety functions and special features 19 |
| | | 3.4 | Software 21 |
| | | 3.5 | Shut-off criteria 22 |
| PAGE | 23 | 4 TECHNICAL DATA | |
| PAGE | 24 | 5 BATTERY ADAPTER | |
| | | 5.1 | Changing the battery adapter 27 |

| | | | |
|------|-----------|------------------------------------|--|
| PAGE | 29 | 6 DRAWINGS | |
| | | 6.1 | 4-bay charger station row form (HST-MV3-04) 29 |
| | | 6.2 | 4-bay charger station cube form (HST-MV3-04W) 29 |
| | | 6.3 | 2-bay charger station (HST-MV3-02) 30 |
| PAGE | 30 | 7 SPARE PARTS LIST | |
| PAGE | 31 | 8 CE CONFORMITY DECLARATION | |



NOTICE

This warning symbol indicates additional information that will make your work easier.



WARNING

General warning to prevent operating errors and failures.



DANGER

This indicates a direct hazard for the worker or the charging station. This warning symbol is especially important and must be followed.

Disposal



Power tools, batteries, accessories and packaging must be disposed of at an environmentally-compatible recycling facility. Power tools and batteries do not go into the household trash.

Only for EU countries:



Directive 2002/96/EG:

Defective power tools must be collected separately and disposed of at an environmentally-compatible recycling facility.

Directive 2006/66/EG:

Defective or drained batteries must be collected separately and disposed of at an environmentally-compatible recycling facility.

Drained batteries can be disposed of directly:

Germany:

Recyclingzentrum Elektrowerkzeuge

Osteroder Landstraße 3

37589 Kalefeld

Transport

Li-Ion batteries are subject to the specifications in the laws pertaining to hazardous goods. The batteries can be transported on roads by the user without further constraints.

When shipping with third parties (e.g.: freight forwarders), special requirements must be observed for packaging and labeling!

Only ship batteries if the casing is not damaged. Cover the contacts with tape and package the battery so it cannot move around in the packaging. Please comply with other national and international requirements.

1. Casing
2. Status LED charger compartment
3. Battery adapter
4. Wake-up button
5. LED signal description



Versions



HST-MV3-04
4-bay charger station
row form



HST-MV3-02
2-bay charger station



HST-MV3-04W
4-bay charger station
cube form

Battery charger station excl. battery adapters

1 GENERAL INFORMATION

1.1 IMPORTANCE OF THE OPERATING INSTRUCTIONS

This information was written with the intention of being read, understood and complied with in all points by persons responsible for the operation of the MV-3 charging station (hereinafter referred to as the charging station). Prior to commissioning, please read the operating instructions and comply with the safety instructions. Work station faults can only be prevented if the contents of these operating instructions are known and fault-free operation can be ensured.

We are not liable for damages and operational errors that result from non-compliance with these operating instructions. If difficulties arise nonetheless, please contact us and we will gladly provide assistance.

1.2 PROPER INTENDED USE

The charging station may only be used, as described in these instructions, to charge batteries suitable for the type of charging station.



NOTICE

Proper intended use also includes:

- complying with all instructions in the operating instructions
- complying with the inspection and maintenance work.

Any other use beyond this is not considered proper intended use. HS-Technik GmbH is **not** liable for any damages resulting from non-compliance.



WARNING

These charging stations are solely suitable for charging Ni-Cd, Ni-MH and Li-Ion batteries 3.6 - 50.4 Volt (nominal voltage 43.2 V).

Not suitable for all battery types!

On page 24, you will find the corresponding battery adapter and its charging functions.

1.3 IMPROPER USE

We are not liable for damages and operational errors that result from non-compliance with these operating instructions or improper use.

1.4 FCC COMPLIANCE

Changes or modifications not expressly approved by HS-Technik could void the user's authority to operate the equipment.

This equipment has been tested and found to comply with the limits for a Class A digital device, pursuant to part 15 of the FCC Rules. These limits are designed to provide reasonable protection against harmful interference when the equipment is operated in a commercial environment. This equipment generates, uses, and can radiate radio frequency energy and, if not installed and used in accordance with the instruction manual, may cause harmful interference to radio communications. Operation of this equipment in a residential area is likely to cause harmful interference in which case the user will be required to correct the interference at his own expense.

1.5 GUARANTEE AND LIABILITY

Guarantee and liability claims for personal and material damages are excluded if they can be traced back to one or more of the following causes:

- improper use
- improper assembly, commissioning, operation and maintenance
- operating the charging station with defective safety equipment or improperly installed or non-functioning safety and protective equipment
- non-compliance with the instruction in the operating instructions pertaining to transport, storage, assembly, commissioning, operation and maintenance of the charging station
- unauthorized structural changes to the charging station
- improper repair
- catastrophes caused by foreign bodies and force majeure

1.6 COPYRIGHT

These operating instructions are only for the operator and its personnel.

They contain the regulations and instructions, which may neither be completely nor partially

- reproduced
- edited or
- otherwise published.

The copyrights to these operating instructions remain with HS-Technik GmbH.

Manufacturer address:

HS-Technik GmbH
High - System - Technik

Im Martelacker 12

D-79588 Efringen-Kirchen

Telephone: 0 76 28 - 91 11-0

Fax: 0 76 28 - 91 11-90

e-mail: info@hs-technik.com

Internet: www.hs-technik.com

2 BASIC SAFETY INSTRUCTIONS

2.1 NOTICES IN THE OPERATING INSTRUCTIONS

- The basic requirement for safe and proper use and fault-free operation is knowledge of the basic safety instructions and safety regulations.
- In addition, the rules and regulations for the place of use must be followed.

2.2 OPERATOR'S RESPONSIBILITY

The operator is obligated to only allow persons to work with this charging station who are familiar with the basic regulations for work safety and accident prevention and are trained in how to use the charging station. Safety-conscious work of the personnel must be checked at regular intervals.

2.2.1 PERSONNEL'S RESPONSIBILITY

All persons working with this charging station are obligated to comply with the basic regulations for work safety and accident prevention prior to starting work.

2.2.2 PERSONNEL TRAINING

Only trained and qualified personnel may work with this charging station. The responsibilities of the personnel for the assembly, commissioning, operation, maintenance and servicing must be clearly defined. Personnel-in-training may only operate the charging station in the presence of an experienced person.

2.3 RISKS WHEN WORKING WITH THE CHARGING STATION

Faults that may hinder safety must be immediately rectified.



WARNING

The charging station was built in accordance with the state of the art in technology and the approved safety regulations. Still, when using it, risks to life and limb of the user or third parties or other material assets may arise.



WARNING

Only use the charging station

- for the proper intended use
- in working order with regards to safety

2.4 DANGER FROM ELECTRICAL ENERGY



DANGER

Only allow a qualified electrician to perform work on this charging station. The electrical equipment of the charging station must be regularly inspected. Loose connections and charred cables must be immediately repaired. If work on the charging station is necessary, the device must be disconnected from the power supply prior to opening it.



WARNING

The charging station must be kept closed at all times. Access is only permitted for authorized persons with a tool.

2.4.1 WORKPLACE SAFETY

- a) **Keep your workspace clean and well lit.**
Disorder or poorly lit workspaces can lead to accidents.
- b) **Do not use the charging station in an explosive environment,**
in which flammable liquids, gases or dusts are located.
- c) **Take environmental influences into account.**
Never subject charging stations to rain.
Do not use charging stations in moist or wet environments.

2.4.2 ELECTRICAL SAFETY

- a) **Avoid physical contact with grounded surfaces such as pipes, radiators, etc.**
There is an increased risk due to electrical shock, if your body is grounded.
- b) **Keep the device away from rain or moisture.**
Water penetrating into charging station tool increases the risk of an electrical shock.
- c) **Keep the charging station away from heat, oil, sharp edges or moving device parts.**

2.4.3 SERVICE



NOTICE

Only allow your charging station to be repaired by a qualified technician using only original replacement parts, available from HS-Technik GmbH. This ensures that the safety of your device is maintained.

2.5 LITHIUM-ION BATTERY



NOTICE

Please make sure to follow the following instructions for using lithium-ion batteries!

- a) **Only charge the batteries in suitable chargers**
If the battery is not used in a suitable charger, it may be permanently damaged.
- b) **If the battery is not used for a longer period of time, it must not remain on the charger or on the tool.**
If a work break of more than 3 hours is expected, the battery must be removed from the tool. Otherwise, the battery may be permanently damaged.
- c) **The lithium-ion battery should not remain on the charger for longer than 36 hours for safety reasons.**
Remove the battery from the charger immediately after the charging process is completed.
- d) **An empty battery should not be in contact with the tool or a charger that is disconnected from the mains for a longer period of time.**
In both cases, currents can flow that deep discharge the battery and can permanently damage it.
- e) **Recharge the lithium-ion batteries immediately and never store them when empty.**
If the battery is stored while disconnected from the tool and the charger, it will maintain a constant capacity over a long period of time. (Loss approx. 5% per year)
- f) **Do not subject the lithium-ion battery to high temperatures (+ 50°C) or direct sunlight.**
If the battery gets warmer than 50°C during operation (charging or discharging), it must be removed from the charger or tool immediately.

- g) Keep the unused battery away from paper clips, coins, keys, nails, screws or other small metal objects which might bridge the contacts. Do not open the battery and do not short-circuit it.**

A short-circuit between the battery contacts can lead to burns, fire or explosions.

- h) Under extreme use or temperature conditions, batteries can leak.**

Avoid contact with the skin or eyes if the battery leaks. The battery fluid is acidic and can cause chemical burns on tissue. If the fluid comes into contact with skin, immediately wash it with soap and water and then rinse it with lemon juice or vinegar. If the fluid gets into the eyes, flush with water for at least 10 minutes and immediately go to the doctor.

- i) Make sure that the Li-Ion battery does not fall down or is subject to vibrations and impacts.**

- j) Clean the contacts on the batteries and charging station regularly with a cloth soaked in high-percentage alcohol or alternatively with a cotton swab.**

NOTICE



Lithium-ion batteries have nearly no self-discharge and do not have a memory effect. If properly used, they will reliably supply your tool with power for several years (approx. 800 - 1,200 charge cycles).

In general the following applies:

Avoid deep discharging or overcharging the lithium-ion battery under any circumstances. It will be permanently damaged from this.

2.6 CLEANING

Use and dispose of used materials and substances properly, in particular cleaning agents and solvents.

2.7 SET-UP

The charging station is only suitable for operation in a dry room. All ventilation slits must be unobstructed. If possible, set up the charging station up away from heaters and sun radiation as an ambient temperature of more than 35° C can result in significantly longer charging times.



WARNING

The charging station must not be operated in closed cabinets.

2.8 POWER SUPPLY

By plugging the power cable into the outlet and toggling the ON/OFF switch on the back, the charging station is ready to use.

3 COMMISSIONING

3.1 BENEFITS

- Battery parameters are measured and processed
- Special HST frequency modulation impulse charging process[®] Anti-memory effect
- Automatic voltage detection
- IFCS - Intelligent Full Charge System for Li-Ion batteries
- Capacity-based charge maintenance mode only for Ni-Cd & NI-MH batteries
- Detection of defective cells
- Protection against reverse polarity
- Can also charge at temperatures > 40° C
- Adapter can be changed in 2 minutes
- Software update via USB
- Suitable for Ni-Cd, Ni-MH and Li-Ion batteries
- With PFC (Power Factor Control)

All common battery types from 3.6 - 50.4 V (43.2 V nominal voltage) such as Atlas-Copco, Bosch, Fein, Makita, Panasonic, Desoutter, HS-Technik etc. can be quickly and reliably charged with the HST-MV3 charging station.



WARNING

The matching battery adapter and the correct software and firmware must be mounted/installed to charge the batteries.

3.2 ADDITIONAL INFORMATION

If the operation voltage is connected and the charging station is switched on, a self test will automatically start.

After switching on the charger, all of the LEDs will light up and then a signal will sound. When all of the LEDs go off, the charging station is ready to use. Now batteries can be inserted for charging.

NOTICE



HS-Technik offers updates for the charging station for download in the course of further development.

The operator is obligated to keep the charging station firmware up-to-date. HS-Technik does not assume any liability for defective batteries if the charging station is not operated with up-to-date firmware.



WARNING

Make sure the polarity +/- is correct.

When replacing batteries, make sure the new battery is not inserted until the LEDs have gone out (red or green).

If a battery is replaced very quickly, the electronics may retain the status of the previous battery pack.

3.2.1 CHARGING PROCESS

Via an initialization routine, the voltage, temperature, short circuits and reverse polarity of the inserted battery are checked.

Prior to starting the charging process, the temperature contacts (NTC contact, etc.) are checked. If the temperature contacts are OK, the battery will be charged.

If the battery is too hot, it can stay in the charging station, and when it has cooled down, it will automatically charge.

If the red LED lights up, the charging process will start using the special HST frequency modulation impulse process® and charge the battery based on how depleted the battery is. During the charging process, the voltage and temperature of the cells and the remaining charging time are continuously monitored.

Taking all of the parameters into account, the charging current and remaining charging time varies on a case-by-case basis. The installed fans switch on automatically, as needed during each charging process.

Every charging process is recorded on a memory chip for subsequent evaluation.

3.2.2 EXPLANATION OF THE LED SIGNALS / FUNCTIONS

When the charging station is not in use, it switches to sleep mode. In order to be able to charge a battery, the station must be activated by pressing the "wake up" button. This is located on the lower left of the front side. If the button is lit green, the charging station is switched on and batteries can be charged. If the button is pressed for longer than 10 seconds, the charging station switches to sleep mode.

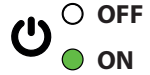

Continuously lit red:

Battery is charging



Continuously lit green:

Battery is fully charged



Blinking blue:

Temperature is too high or too low to charge. If the temperature of the battery is below 10° C, the LED will blink blue and the charging station will only charge the battery with 500 mA up to a temperature of 10° C has been reached. From then on, the station will charge the battery normally. The same applies when the temperature of the battery exceeds 55° C; the battery will also be charged with 500 mA until the temperature of the battery drops below 55° C.



Blinking red/blue:

The charging station cannot find a temperature contact. In most cases, the battery contact is defective or damaged.



Blinking red:

The battery is defective. The charging station cannot find a measurable voltage.

Blinking yellow:

The battery voltage is too high or too low for the battery type. This battery cannot be charged.



3.2.3 SLEEP FUNCTION

The sleep function defines the time after which the charging station or the boards switches to sleep mode when it is not charging batteries. The time can be set freely up to 18:12:15 hours via the software. The charging station can be woken up from sleep mode by pressing the wake up button on the front or by pulling on a battery. Each board goes into sleep mode separately after the set time if it is not in use. If the last board goes in sleep mode the power supply will shut off.



NOTICE

Prior to use, always check that the mounted battery adapter is compatible with the battery you wish to charge.

3.3 SAFETY FUNCTIONS AND SPECIAL FEATURES

The battery is charged using the HST frequency modulation impulse charging process[®] until a charging parameter is reached, then the charger switches to charge retention mode. A microprocessor monitors and controls every charging box and only supplies the battery with as much energy as it can effectively absorb (dialog between the battery and charging station).

This results in low heat development and faster and better storage of the capacity. This special charging technology ensures the charging process is always extremely gentle on the battery and guarantees a very long service life of the battery. Furthermore, this dynamic charging technology automatically regenerates older batteries (that were charged with other chargers) with reduced capacity, so these batteries can continue to be used.

No "memory effect" for Ni-Cd and Ni-MH batteries, due to the special charging technology, the residual energy in the cells is shifted which prevents accumulation or crystallization of the electrolytes. Every time the battery is charged, the cells are reformatted and the electromechanical balance is rearranged. Thus, the voltage curve when discharging is significantly higher than with other comparable charging processes. (More energy in the form of joules can be discharged).

Higher capacity at lower currents.

The charging boxes are completely short-circuit-proof and protected against reverse polarity so the batteries will not be destroyed. If the polarity is reversed or there is a short-circuit, the charging box is disconnected from the power supply and a signal will sound, accompanied by a red blinking LED.

(The highest level of safety is thus ensured.)

The fans are controlled based on need and cool the batteries quickly, even under extreme stress.

Absolute protection against overloading via voltage monitoring and voltage gradient evaluation as well as Delta U, charging time limitation and dynamic temperature evaluation.

Automatic dynamic evaluation of the temperature contacts depending on the adapter type.



NOTICE

Only for Ni-Cd and Ni-MH batteries.

3.4 SOFTWARE

- Special HST frequency modulation impulse charging process* (absolutely no memory effect due to variable frequency-modulated impulse charging current with a high amplitude)
- Self diagnostic (test of the internal power circuit)
- Polarity reversal protection (power is disconnected from the charging box, accompanied by a signal and a red blinking LED, disconnect charging box - battery)
- Special charge mode for Ni-Cd batteries (for deep discharging or dormant batteries)
- No voltage change required (battery voltage is detected automatically)
- Charging at battery temperatures exceeding 40° C (by generating gradients using dynamic temperature evaluation)
- Automatic evaluation of the temperature contacts (with NTC contact, a dynamic temperature evaluation is performed, this depends on the battery adapter.)
- Defective cell detection (red blinking LED = battery is defective or battery no longer has full capacity)
- Status indication via LED (red = charging / green = full)
- Charging effectiveness higher than 95%
- Fan control
- New, capacity-related charge retention mode for Ni-Cd and Ni-MH (prevents the charging capacities in the battery pack from drifting apart)
- Suitable for Li-Ion batteries
- 3.6 V - 50.4 V (43.2V nominal voltage)

3.5 SHUT-OFF CRITERIA

- Dynamic temperature evaluation (temperature gradient evaluation)
- Capacity-related full detection
- ΔU detection and voltage gradient evaluation (automatic parameter definition based on the charge status of the battery pack)
- Battery analysis and characteristic diagram control prior to and during the charging process (charging parameters are automatically determined and defined based on the battery pack)
- Plausibility test (check whether the battery parameters are logical with regard to each other)

4 TECHNICAL DATA

| | |
|---|---|
| Model | HST-MV3-xx |
| Input | 85 - 260 V AC, 47 - 63 Hz |
| Output | 56 V / max. 624 VA |
| Level of efficiency | > 89 % |
| Power supply ventilator | ≤ 45°C / 113°F (OFF) ≥ 50°C / 122°F (ON) |
| Weight | HST-MV3-02 without battery adapter approx. 4,9 kg HST-MV3-02 with battery adapter approx. 5,7 kg HST-MV3-04 row form without battery adapter approx. 8,2 kg HST-MV3-04 row form with battery adapter approx. 8,8 kg HST-MV3-04 cube form without battery adapter approx. 8,5 kg HST-MV3-04 cube form with battery adapter approx. 9,5 kg |
| Dimensions (W x H x D) in mm without battery adapter | HST-MV3-02 289 x 182 x 260 mm (incl. feet) HST-MV3-04 (row form) 539 x 182 x 260 mm (incl. feet) HST-MV3-04W (cube form) 289 x 330 x 260 mm (incl. feet) |
| Compliance | CE, FCC |

5 BATTERY ADAPTER

| ORDER-NO. | TO BE CHARGED BATTERY TYPES |
|-------------|--|
| M-MV3-PR | HS-Technik HST-PR, 14,4 V & 18 V Li-Ion Titgemeyer TIOS-LIO, 18 V Li-Ion |
| M-MV3-BH | Makita Makstar (BL), 14,4 V & 18 V Li-Ion Makita Makstar (BH), 9,6 V - 24 V Ni-MH HST-BL, 14,4 V & 18 V Li-Ion HST-BH, 9,6 V - 24 V Ni-MH |
| M-MV3-BO-LI | Bosch, 14,4 V & 18 V Li-Ion |
| M-MV3-BO-10 | Bosch 10,8 V Li-Ion |
| M-MV3-BO-NI | Bosch, 7,2 V - 18 V Ni-Cd & Ni-MH |
| M-MV3-FEIN | Fein ASM / ASW 10,8, 14,4 & 18 V Li-Ion |
| M-MV3-CPN | Atlas Copco, 18 V & 36 V Li-Ion Dessouter, 18 V & 36 V Li-Ion |
| M-MV3-CPT | Cooper Powertools, 26 V & 44 V Li-Ion |
| M-MV3-UNI | Gesipa 14,4 V Li-Ion Gesipa 12 V Ni-Cd und Ni-MH Makita 7,2 - 24V Ni-Cd und Ni-MH Bosch 7,2 - 18V Ni-Cd und Ni-MH |
| M-MV3-PA-LI | Panasonic 7,2 V, 10,8 V, 14,4 V, 18 V, 21,6 V, 28,8 V Li-Ion |
| M-MV3-GE | Gesipa 18 V Li-Ion |
| M-MV3-MA-10 | Makita Makstar (BL), 10,8 V Li-Ion |
| M-MV3-MA-72 | Makita Makstar (BL), 7,2 V Li-Ion |
| M-MV3-PA-36 | Panasonic, 3,6 V Li-Ion |
| M-MV3-AC | Atlas Copco System 3000, 9,6 - 18 V Ni-Cd & Ni-MH |
| M-MV3-AC30 | Atlas Copco System, 30 V Li-Ion |
| M-MV3-IR | Ingersol Rand Li-Ion Akkus 20 V + 40 V |
| M-MV3-M10 | Mirka 10,8 V-2,0 Ah |
| M-MV3-PA-72 | Makita, 7,2 V Li-Ion |
| M-MV3-REX | Rexroth |
| M-MV3-SCS | Type SCS 3,6V |

A battery adapter alone cannot charge batteries; it can only be used in combination with a 2, 4 or 8 bay charging station. Different battery adapters can be mounted on one charging station on multi-bay charging stations. If you require battery adapters for older charging stations, please contact us.

Additional battery adapters upon request.

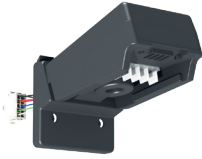

M-MV3-PR

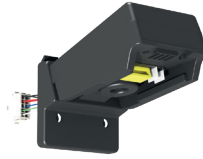

M-MV3-BH



M-MV3-BO-LI



M-MV3-BO-10



M-MV3-BO-NI

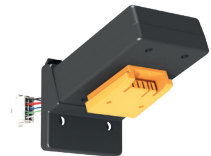

M-MV3-FEIN



M-MV3-CPN



M-MV3-CPT



M-MV3-UNI

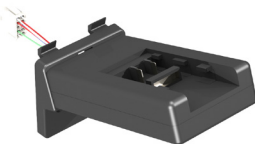

M-MV3-PA-LI

no picture

no picture

M-MV3-GE

M-MV3-MA-10

no picture



M-MV3-MA-72

M-MV3-PA-36



M-MV3-AC



M-MV3-AC30



M-MV3-IR

no picture

M-MV3-M10



M-MV3-PA-72



M-MV3-REX



M-MV3-SCS

5.1 CHANGING THE BATTERY ADAPTER

In order to mount another battery adapter, proceed as follows:

The charging station must be switched off and the power supply must be disconnected prior to changing the adapter. Then, the battery which needs to be changed must be loosened, so that the circuit board of the battery adapter is accessible.

There are 4 different designs / basic forms of battery adapters. After loosening the mountings, all 4 designs are removed in the same manner. To do this, lift the adapter up slightly and pull it out to the top.



WARNING

Only authorized specialists are permitted to change the battery adapter.
For the exchange is no electrical qualified personnel required.



DANGER

Be careful of sharp edges!

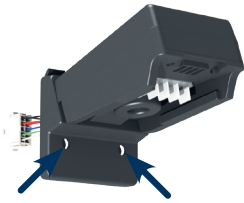

Design 1

Rotate the two flathead screws approx. half a turn.

 loosen (CW)

 mount (CCW)

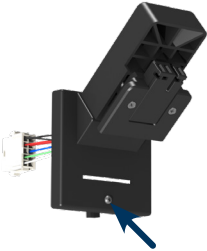

Design 2

Loosen the torx screw in the middle by approx. a quarter of a turn to the left. Do not loosen the screws to far, because the nut can be loosen then too.

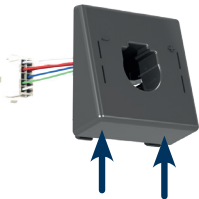

Design 3

Loosen the two torx screws on the bottom of the adapter by approx. 8 - 10 turns to the left.



Design 4

Loosen the flathead screw in the middle of the bottom of the battery adapter.

After loosening the battery adapter the connection plug must be removed from the board. Hereto the small locking mechanism needs to be pushed to open it. Then the plug can be removed. In order to connect a new battery adapter the locking mechanism must be locked again.

Install adapters by following these steps:

Place/plug in the connection plug onto the circuit board

Insert and screw down the battery adapter

6 DRAWINGS

6.1 4-BAY CHARGER STATION ROW FORM (HST-MV3-04)

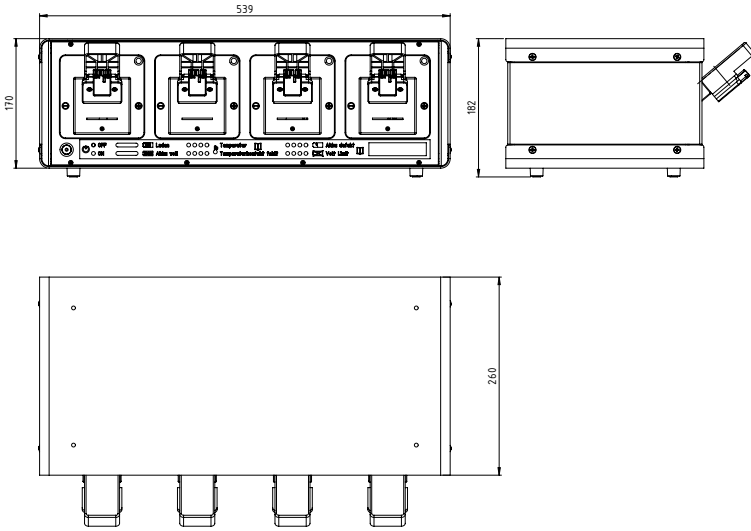

6.2 4-BAY CHARGER STATION CUBE FORM (HST-MV3-04W)

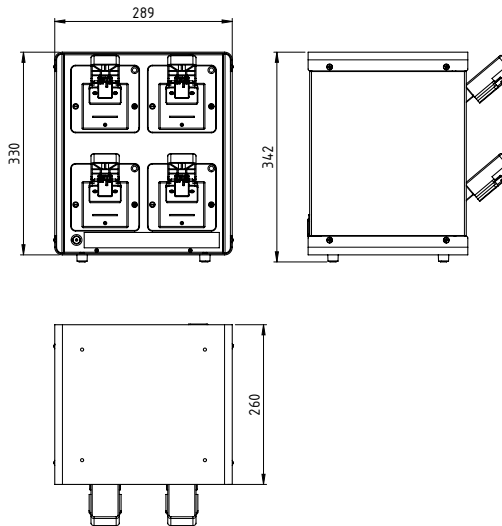

Dimensions in mm (without battery adapter)

6.3 2-BAY CHARGER STATION (HST-MV3-02)

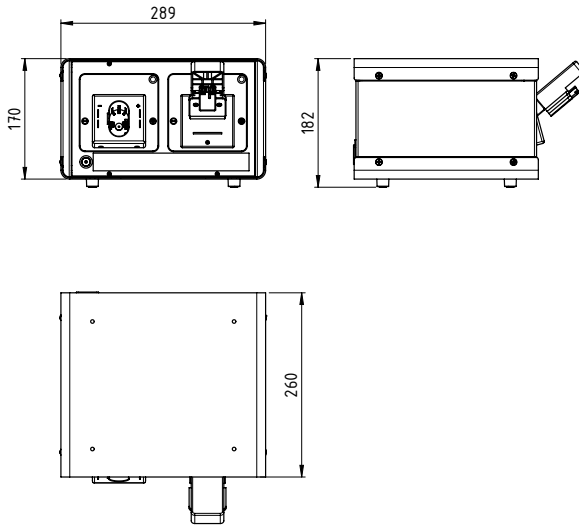

Dimensions in mm (without battery adapter)

7 SPARE PARTS LIST

You can request a replacement parts list from info@hs-technik.com or via telephone +49 (0)7628 / 91 11 0.

8 CE CONFORMITY DECLARATION

We herewith declare that the devices specified below comply with the relevant EC guidelines with regards to design and construction type.

If the devices are modified without our authorization, this declaration will be null and void.

The devices specified below comply with the valid EGB / EMV standards applicable at the time of publication.

Description of the device: Charging station for charging Ni-Cd, Ni-MH and Li-Ion batteries from different manufacturers with 3,6 - 43,2 V and NTC temperature monitoring

Model: HST-MV3-xx

Manufacturer: HS-Technik GmbH
Im Martelacker 12
D-79588 Efringen-Kirchen

Guidelines: 2014/35/EU
2014/30/EU

Applied EC guidelines: EN 60335-1:2012
EN 60335-2-29:2004+A2:2010
EN 55011:2016
EN 61000-6-2:2005
EN 61000-3-2:2014
EN 61000-3-3:2013

HS-Technik GmbH
Im Martelacker 12, D-79588 Efringen-Kirchen



H.-Martin Hanke
Manager

Efringen-Kirchen, in August 2018

HS-Technik GmbH

High - System - Technik

Im Martelacker 12

D-79588 Efringen-Kirchen

Phone: +49 (0) 76 28 - 91 11-0

Fax: +49 (0) 76 28 - 91 11-90

E-Mail: info@hs-technik.com

Internet: www.hs-technik.com

Die technischen Daten in dieser Drucksache geben einen Anhalt, sind aber ohne Gewähr!
Konstruktionsänderungen vorbehalten. Unsere Konstruktionsvorschläge sind unverbindlich!

The technical data in these printed material provide support, but are not guaranteed! Constructional
changes reserved. Our construction recommendations are non-binding!