

FCC

SAR

TEST REPORT

ISSUED BY
Shenzhen BALUN Technology Co., Ltd.



FOR
4G Smart phone

ISSUED TO
CommuniTake Technologies Ltd.

Yokneam Star Building, High-Tech Park, POB 344, Yokneam, Israel
2069205



Tested by: Zeng Liyao
Zeng Liyao
(Engineer)

Date: Jan. 08, 2020

Approved by: Wei Yanquan
Wei Yanquan
(Chief Engineer)

Date: Jan. 08, 2020

Report No.: BL-SZ1970095-701

EUT Name: 4G Smart phone

Model Name: CTGED01

Brand Name: CommuniTake

FCC ID: 2AUHC-CTGED01A

Test Standard: FCC 47 CFR Part 2.1093

ANSI C95.1: 1999

IEEE 1528: 2013

Maximum SAR: Head (1 g): 0.780 W/kg

Body (1 g): 0.964 W/kg

Test Conclusion: Pass

Test Date: Sep. 08, 2019 ~ Sep. 18, 2019

Date of Issue: Jan. 08, 2020

NOTE: This test report of test results only related to testing samples, which can be duplicated completely for the legal use with the approval of the applicant; it shall not be reproduced except in full, without the written approval of Shenzhen BALUN Technology Co., Ltd. Any objections should be raised within thirty days from the date of issue. To validate the report, please contact us.

Revision History

<u>Version</u>	<u>Issue Date</u>	<u>Revisions Content</u>
<u>Rev. 01</u>	<u>Jan. 08, 2020</u>	<u>Initial Issue</u>

TABLE OF CONTENTS

1	ADMINISTRATIVE DATA (GENERAL INFORMATION)	5
1.1	Identification of the Testing Laboratory	5
1.2	Identification of the Responsible Testing Location	5
1.3	Test Environment Condition	5
1.4	Announce	5
2	PRODUCT INFORMATION	6
2.1	Applicant Information	6
2.2	Manufacturer Information	6
2.3	Factory Information	6
2.4	General Description for Equipment under Test (EUT)	6
2.5	Ancillary Equipment	6
2.6	Technical Information	7
3	SUMMARY OF TEST RESULTS	8
3.1	Test Standards	8
3.2	Device Category and SAR Limit	9
3.3	Test Result Summary	10
3.4	Test Uncertainty	11
4	SAR MEASUREMENT SYSTEM	12
4.1	Definition of Specific Absorption Rate (SAR)	12
4.2	SATIMO SAR System	12
5	SYSTEM VERIFICATION	21
5.1	Antenna Port Test Requirement	21
5.2	Purpose of System Check	21
5.3	System Check Setup	21
6	EUT TEST POSITION CONFIGURATIONS	22
6.1	Body-worn Position Conditions	22

6.2	Hotspot Mode Exposure Position Conditions	23
7	SAR MEASUREMENT PROCEDURES	24
7.1	SAR Measurement Process Diagram	24
7.2	SAR Scan General Requirements.....	25
7.3	SAR Measurement Procedure	26
7.4	Area & Zoom Scan Procedures.....	26
8	CONDUCTED RF OUPUT POWER.....	27
8.1	GSM	27
8.2	WCDMA	28
8.3	LTE.....	29
8.4	WIFI.....	36
8.5	Bluetooth	36
9	EUT ANTENNA LOCATION SKETCH	37
9.1	SAR Test Exclusion Consider Table	38
9.2	10g Extremity Exposure Consider.....	40
10	TEST RESULTS	41
10.1	GSM 850	41
10.2	GSM 1900	41
10.3	WCDMA Band 2	42
10.4	WCDMA Band 4	42
10.5	WCDMA Band 5	43
10.6	LTE Band 2 (20MHz Bandwidth).....	43
10.7	LTE Band 4 (20MHz Bandwidth).....	44
10.8	LTE Band 5 (10MHz Bandwidth).....	45
10.9	LTE Band 7 (20MHz Bandwidth).....	46
10.10	LTE Band 12 (10MHz Bandwidth).....	47
10.11	LTE Band 17 (10MHz Bandwidth).....	48
10.12	WIFI 2.4GHz.....	48
11	SAR Measurement Variability.....	49
12	SIMULTANEOUS TRANSMISSION	50
12.1	Simultaneous Transmission Mode Consider.....	50

12.2	Estimated SAR Calculation	51
12.3	Sum SAR of Simultaneous Transmission	52
13	TEST EQUIPMENTS LIST	54
ANNEX A	SIMULATING LIQUID VERIFICATION RESULT	55
ANNEX B	SYSTEM CHECK RESULT	56
ANNEX C	TEST DATA.....	73
ANNEX D	EUT EXTERNAL PHOTOS.....	97
ANNEX E	SAR TEST SETUP PHOTOS.....	97
ANNEX F	CALIBRATION REPORT	97

1 ADMINISTRATIVE DATA (GENERAL INFORMATION)

1.1 Identification of the Testing Laboratory

Company Name	Shenzhen BALUN Technology Co., Ltd.
Address	Block B, 1st FL, Baisha Science and Technology Park, Shahe Xi Road, Nanshan District, Shenzhen, Guangdong Province, P. R. China
Phone Number	+86 755 6685 0100

1.2 Identification of the Responsible Testing Location

Test Location	Shenzhen BALUN Technology Co., Ltd.
Address	Block B, 1st FL, Baisha Science and Technology Park, Shahe Xi Road, Nanshan District, Shenzhen, Guangdong Province, P. R. China
Accreditation Certificate	<p>The laboratory has been listed by Industry Canada to perform electromagnetic emission measurements. The recognition numbers of test site are 11524A-1.</p> <p>The laboratory is a testing organization accredited by FCC as a accredited testing laboratory. The designation number is CN1196.</p> <p>The laboratory is a testing organization accredited by American Association for Laboratory Accreditation (A2LA) according to ISO/IEC 17025. The accreditation certificate is 4344.01.</p> <p>The laboratory is a testing organization accredited by China National Accreditation Service for Conformity Assessment (CNAS) according to ISO/IEC 17025. The accreditation certificate number is L6791.</p>
Description	All measurement facilities used to collect the measurement data are located at Block B, FL 1, Baisha Science and Technology Park, Shahe Xi Road, Nanshan District, Shenzhen, Guangdong Province, P. R. China 518055

1.3 Test Environment Condition

Ambient Temperature	21°C to 23°C
Ambient Relative Humidity	37% to 48%
Ambient Pressure	100 to 102KPa

1.4 Announce

- (1) The test report reference to the report template version v2.3.
- (2) The test report is invalid if not marked with the signatures of the persons responsible for preparing and approving the test report.
- (3) The test report is invalid if there is any evidence and/or falsification.
- (4) The results documented in this report apply only to the tested sample, under the conditions and modes of operation as described herein.
- (5) This document may not be altered or revised in any way unless done so by BALUN and all revisions are duly noted in the revisions section.
- (6) Content of the test report, in part or in full, cannot be used for publicity and/or promotional purposes without prior written approval from the laboratory.

2 PRODUCT INFORMATION

2.1 Applicant Information

Applicant	CommuniTake Technologies Ltd.
Address	Yokneam Star Building, High-Tech Park, POB 344, Yokneam, Israel 2069205

2.2 Manufacturer Information

Manufacturer	CommuniTake Technologies Ltd.
Address	Yokneam Star Building, High-Tech Park, POB 344, Yokneam, Israel 2069205

2.3 Factory Information

Factory	Shenzhen Joyhong Technology Co., Ltd.
Address	4/F., Building A2, Zhengfeng Industrial Park, Fengtang Road, Fuyong, Bao'an, Shenzhen, China

2.4 General Description for Equipment under Test (EUT)

EUT Name	4G Smart phone
Model Name Under Test	CTGED01
Series Model Name	N/A
Description of Model name differentiation	N/A
Hardware Version	N/A
Software Version	N/A
Dimensions (Approx.)	N/A
Weight (Approx.)	N/A

2.5 Ancillary Equipment

Note: not application.

2.6 Technical Information

Network and Wireless connectivity	2G Network GSM/GPRS/EDGE 850/1900 MHz 3G Network WCDMA/HSDPA/HSUPA Band 2/4/5 4G Network FDD LTE Band 2/4/5/7/12/17 Bluetooth 4.2 (BR+EDR+BLE) WIFI 802.11b, 802.11g, 802.11n(HT20/40)
Note : The EUT is a mobile phone, which supports dual SIM card under the same transceiver. Each SIM supports GSM, WCDMA and LTE, and both SIM share the same transmitting electro circuit, NV parameters, so only SIM1 was tested in this report.	

The requirement for the following technical information of the EUT was tested in this report:

Operating Mode	GSM, WCDMA, FDD-LTE, 2.4G WLAN, Bluetooth		
Frequency Range	GSM 850	TX: 824 ~ 849 MHz	RX: 869 ~ 894 MHz
	GSM 1900	TX: 1850 ~ 1910 MHz	RX: 1930 ~ 1990 MHz
	WCDMA Band 2	TX: 1850 ~ 1910 MHz	RX: 1930 ~ 1990 MHz
	WCDMA Band 4	TX: 1710 ~ 1755 MHz	RX: 2110 ~ 2155 MHz
	WCDMA Band 5	TX: 824 ~ 849 MHz	RX: 869 ~ 894 MHz
	LTE Band 2	TX: 1850 ~ 1910 MHz	RX: 1930 ~ 1990 MHz
	LTE Band 4	TX: 1710 ~ 1755 MHz	RX: 2110 ~ 2155 MHz
	LTE Band 5	TX: 824 ~ 849 MHz	RX: 869 ~ 894 MHz
	LTE Band 7	TX: 2500 ~ 2570 MHz	RX: 2620 ~ 2690 MHz
	LTE Band 12	TX: 699 ~ 716 MHz	RX: 729 ~ 746 MHz
	LTE Band 17	TX: 704 ~ 716 MHz	RX: 734 ~ 746 MHz
	802.11b/g/n(HT20/HT40)	2400 ~ 2483.5 MHz	
Antenna Type	WWAN: PIFA Antenna WLAN: PIFA Antenna Bluetooth: PIFA Antenna		
DTM	Not Support		
Hotspot Function	Support		
Power Reduction	Not Support		
Exposure Category	General Population/Uncontrolled exposure		
EUT Stage	Portable Device		
Product	Type		
	<input checked="" type="checkbox"/> Production unit	<input type="checkbox"/> Identical prototype	

3 SUMMARY OF TEST RESULTS

3.1 Test Standards

No.	Identity	Document Title
1	47 CFR Part 2	Frequency Allocations and Radio Treaty Matters; General Rules and Regulations
2	ANSI/IEEE Std. C95.1-1999	IEEE Standard for Safety Levels with Respect to Human Exposure to Radio Frequency Electromagnetic Fields, 3 kHz to 300 GHz
3	IEEE Std. 1528-2013	Recommended Practice for Determining the Peak Spatial-Average Specific Absorption Rate (SAR) in the Human Head from Wireless Communications Devices: Measurement Techniques
4	FCC KDB 447498 D01 v06	Mobile and Portable Device RF Exposure Procedures and Equipment Authorization Policies
5	FCC KDB 941225 D01 v03r01	3G SAR MEAUREMENT PROCEDURES
6	FCC KDB 941225 D05 v02r05	SAR Evaluation Considerations for LTE Devices
7	FCC KDB 941225 D06 v02r01	SAR Evaluation Procedures for Portable Devices with Wireless Router Capabilities
8	FCC KDB 865664 D01 v01r04	SAR Measurement 100 MHz to 6 GHz
9	FCC KDB 865664 D02 v01r02	RF Exposure Reporting
10	FCC KDB 648474 D04 v01r03	SAR Evaluation Considerations for Wireless Handsets
11	KDB 248227 D01 v02r02	SAR Guidance for IEEE 802.11 (Wi-Fi) Transmitters

3.2 Device Category and SAR Limit

This device belongs to portable device category because its radiating structure is allowed to be used within 20 centimeters of the body of the user. Limit for General Population/Uncontrolled exposure should be applied for this device, it is 1.6 W/kg as averaged over any 1 gram of tissue.

Table of Exposure Limits:

Body Position	SAR Value (W/Kg)	
	General Population/ Uncontrolled Exposure	Occupational/ Controlled Exposure
Whole-Body SAR (averaged over the entire body)	0.08	0.4
Partial-Body SAR (averaged over any 1 gram of tissue)	1.60	8.0
SAR for hands, wrists, feet and ankles (averaged over any 10 grams of tissue)	4.0	20.0

NOTE:

General Population/Uncontrolled: Locations where there is the exposure of individuals who have no knowledge or control of their exposure. General population/uncontrolled exposure limits are applicable to situations in which the general public may be exposed or in which persons who are exposed as a consequence of their employment may not be made fully aware of the potential for exposure or cannot exercise control over their exposure. Members of the general public would come under this category when exposure is not employment-related; for example, in the case of a wireless transmitter that exposes persons in its vicinity.

Occupational/Controlled: Locations where there is exposure that may be incurred by persons who are aware of the potential for exposure, In general, occupational/controlled exposure limits are applicable to situations in which persons are exposed as a consequence of their employment, who have been made fully aware of the potential for exposure and can exercise control over their exposure. This exposure category is also applicable when the exposure is of a transient nature due to incidental passage through a location where the exposure levels may be higher than the general population/uncontrolled limits, but the exposed person is fully aware of the potential for exposure and can exercise control over his or her exposure by leaving the area or by some other appropriate means.

3.3 Test Result Summary

3.3.1 Highest SAR (1 g Value)

Band	Maximum Scaled SAR (W/kg)			Maximum Report SAR (W/kg)			Limit (W/kg)
	Head	Body-worn	Hotspot	Head	Body-worn	Hotspot	
GSM 850	0.780	0.961	0.961	0.780	0.964	0.964	1.6
GSM 1900	0.202	0.552	0.552				
WCDMA Band 2	0.230	0.626	0.626				
WCDMA Band 4	0.431	0.964	0.964				
WCDMA Band 5	0.387	0.504	0.504				
LTE Band 2	0.263	0.541	0.541				
LTE Band 4	0.607	0.792	0.792				
LTE Band 5	0.491	0.641	0.641				
LTE Band 7	0.124	0.214	0.214				
LTE Band 12	0.261	0.488	0.488				
LTE Band 17	0.296	0.508	0.508				
2.4G WLAN	0.515	0.195	0.195				
Verdict	Pass						

3.3.2 Highest Simultaneous SAR

Position	Simultaneous Configuration	Simultaneous SAR (W/kg)	Limit (W/kg)	Verdict
Head	GSM + 2.4G WLAN	1.295	1.6	Pass
Body-worn	WCDMA RMC + 2.4G WLAN	1.159	1.6	Pass
Hotspot Mode	WCDMA RMC + 2.4G WLAN	1.159	1.6	Pass

3.4 Test Uncertainty

According to KDB 865664 D01, when the highest measured 1 g SAR within a frequency band is < 1.5 W/kg, the extensive SAR measurement uncertainty analysis is not required in SAR reports submitted for equipment approval.

The maximum 1 g SAR for the EUT in this report is 0.964 W/kg, which is lower than 1.5 W/kg, so the extensive SAR measurement uncertainty analysis is not required in this report.

4 SAR MEASUREMENT SYSTEM

4.1 Definition of Specific Absorption Rate (SAR)

SAR is related to the rate at which energy is absorbed per unit mass in an object exposed to a radio field. The SAR distribution in a biological body is complicated and is usually carried out by experimental techniques or numerical modeling. The standard recommends limits for two tiers of groups, occupational/controlled and general population/uncontrolled, based on a person's awareness and ability to exercise control over his or her exposure. In general, occupational / controlled exposure limits are higher than the limits for general population /uncontrolled.

The SAR definition is the time derivative (rate) of the incremental energy (dW) absorbed by (dissipated in) an incremental mass (dm) contained in a volume element (dv) of a given density (ρ). The equation description is as below:

$$\text{SAR} = \frac{d}{dt} \left(\frac{dW}{dm} \right) = \frac{d}{dt} \left(\frac{dW}{\rho dv} \right)$$

SAR is expressed in units of Watts per kilogram (W/kg) SAR measurement can be related to the electrical field in the tissue by

$$\text{SAR} = \frac{\sigma E^2}{\rho}$$

Where: σ is the conductivity of the tissue,

ρ is the mass density of the tissue and E is the RMS electrical field strength.

4.2 SATIMO SAR System

4.2.1 SATIMO SAR System Diagram

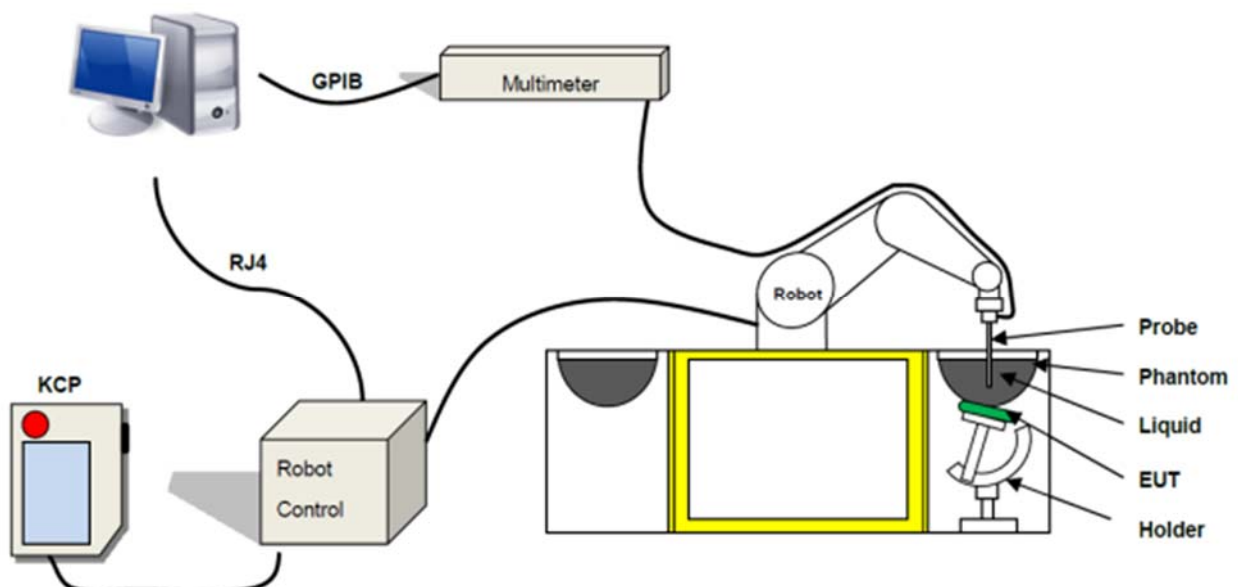

These measurements were performed with the automated near-field scanning system OPENSAR from SATIMO. The system is based on a high precision robot (working range: 850 mm), which positions the probes with a positional repeatability of better than ± 0.02 mm. Special E- and H-field probes have been developed for measurements close to material discontinuity, the sensors of which are directly loaded with a Schottky diode and connected via highly resistive lines to the data acquisition unit.

The SAR measurements were conducted with dosimetric probe (manufactured by SATIMO), designed in the classical triangular configuration and optimized for dosimetric evaluation. The probe has been calibrated according to the procedure described in SAR standard with accuracy of better than $\pm 10\%$. The spherical isotropy was evaluated with the procedure described in SAR standard and found to be better than ± 0.25 dB. The phantom used was the SAM Phantom as described in FCC supplement C, IEEE P1528.

4.2.2 Robot

The SATIMO SAR system uses the high precision robots from KUKA. For the 6-axis controller system, the robot controller version (KUKA) from KUKA is used. The KUKA robot series have many features that are important for our application:



- High precision (repeatability ± 0.035 mm)
- High reliability (industrial design)
- Jerk-free straight movements
- Low ELF interference (the closed metallic construction shields against motor control fields)

4.2.3 E-Field Probe

For the measurements the Specific Dosimetric E-Field Probe SN 34/15 EPGO 265 with following specifications is used

- Dynamic range: 0.01-100 W/kg
 - Tip Diameter : 2.5 mm
 - Lower detection limit : 10 mW/kg
(repeatability better than +/- 1mm)
 - Probe linearity: +/- 0.07 dB
 - Calibration range: 300 MHz to 6000 MHz for head & body simulating liquid.
- Angle between probe axis (evaluation axis) and surface normal line: less than 30°



E-Field Probe Calibration Process

Probe calibration is realized, in compliance with CENELEC EN 62209-1/-2 and IEEE 1528 std, with CALISAR, Antennessa proprietary calibration system. The calibration is performed with the IEC62209-1/2 annexe technique using reference guide at the five frequencies.

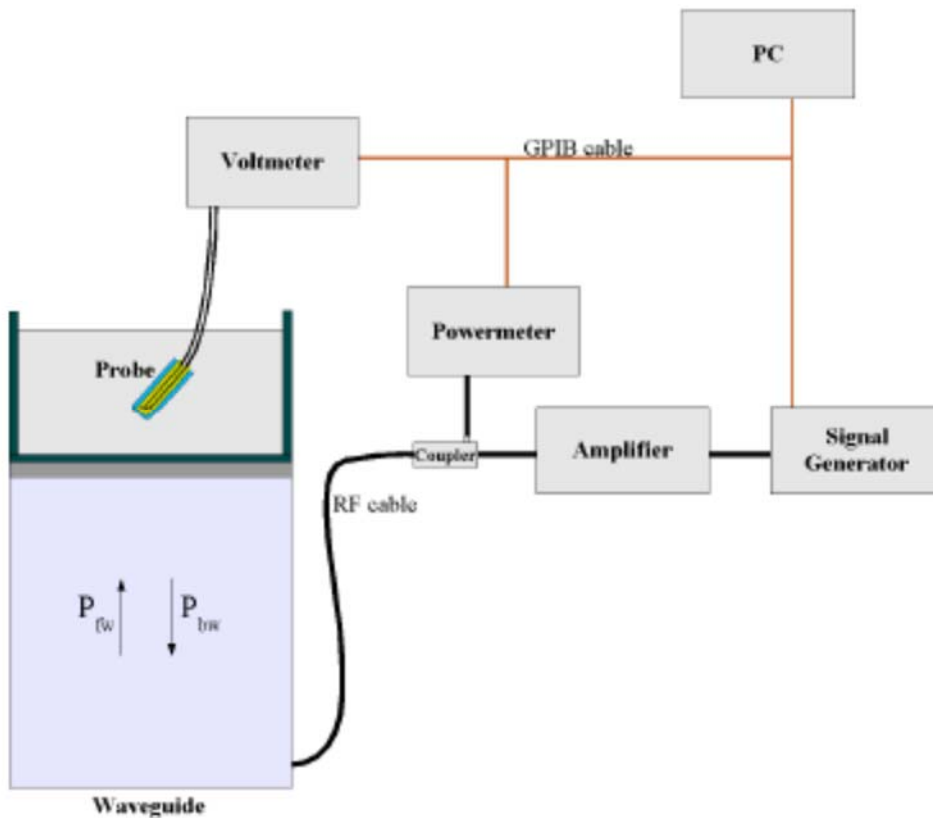

$$SAR = \frac{4(P_{fw} - P_{bw})}{ab\sigma} \cos^2 \left(\pi \frac{y}{a} \right) e^{-(2\pi/\sigma)z}$$

Where :

P_{fw} = Forward Power

P_{bw} = Backward Power

a and b = Waveguide Dimensions

σ = Skin Depth

Keithley configuration

Rate = Medium; Filter = ON; RDGS = 10; FILTER TYPE = MOVING AVERAGE; RANGE AUTO After each calibration, a SAR measurement is performed on a validation dipole and compared with a NPL calibrated probe, to verify it.

The calibration factors, CF(N), for the 3 sensors corresponding to dipole 1, dipole 2 and dipole 3 are:

$$CF(N) = SAR(N) / V_{lin}(N) \quad (N=1,2,3)$$

The linearised output voltage V_{lin}(N) is obtained from the displayed output voltage V(N) using

$$V_{lin}(N) = V(N) * (1 + V(N) / DCP(N)) \quad (N=1,2,3)$$

Where the DCP is the diode compression point in mV.

4.2.4 Phantoms

For the measurements the Specific Anthropomorphic Mannequin (SAM) defined by the IEEE SCC-34/SC2 group is used. The phantom is a polyurethane shell integrated in a wooden table. The thickness of the phantom amounts to 2mm +/- 0.2mm. It enables the dosimetric evaluation of left and right phone usage and includes an additional flat phantom part for the simplified performance check. The phantom set-up includes a cover, which prevents the evaporation of the liquid.

Photo of Phantom SN 30/13 SAM103



Photo of Phantom SN 30/13 SAM104



Serial Number	Positionner Material	Permittivity	Loss Tangent
SN 30/13 SAM103	Gelcoat with fiberglass	3.4	0.02
SN 30/13 SAM104	Gelcoat with fiberglass	3.4	0.02

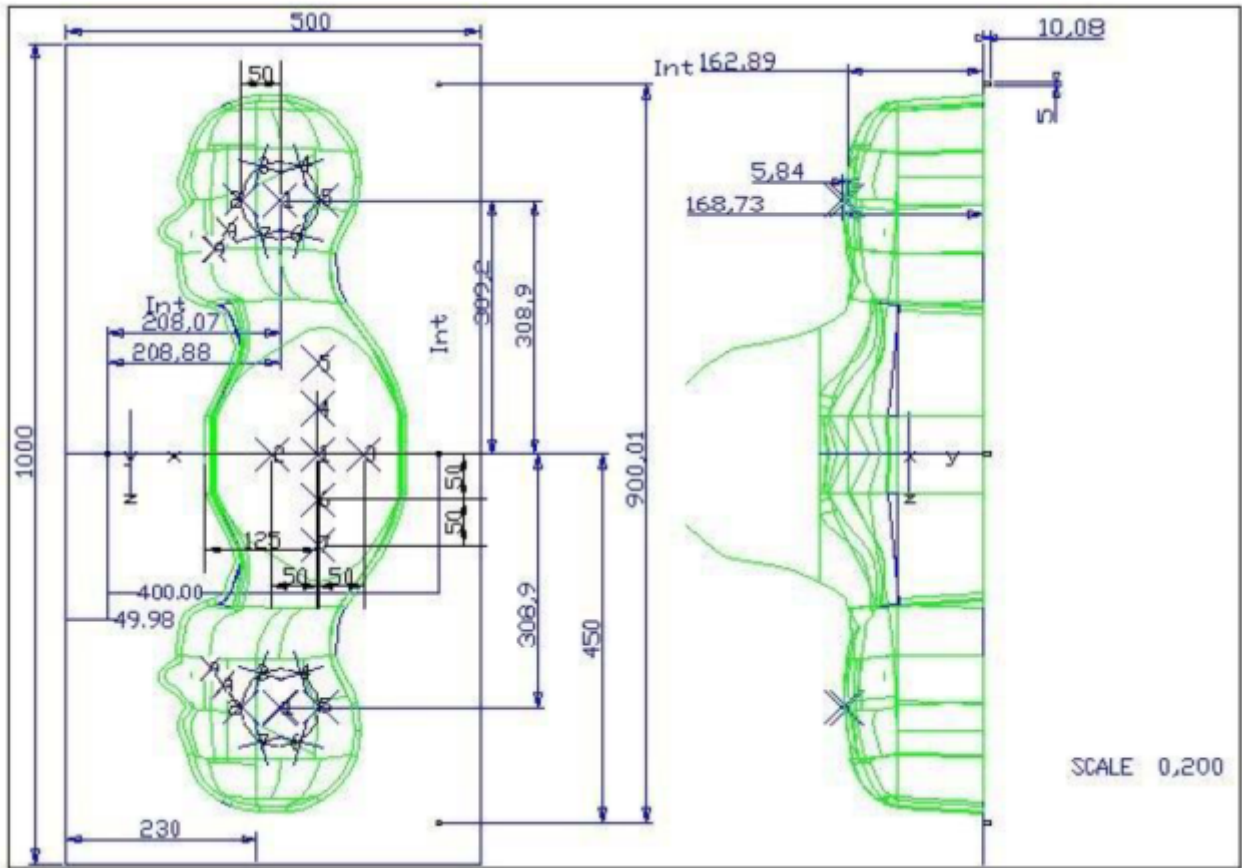

Serial Number	Left Head		Right Head		Flat Part	
SN 30/13 SAM103	2	2.00	2	2.03	1	2.09
	3	2.02	3	2.05	2	2.10
	4	2.04	4	2.04	3	2.09
	5	2.04	5	2.07	4	2.11
	6	2.02	6	2.07	5	2.11
	7	2.01	7	2.09	6	2.09
	8	2.04	8	2.10	7	2.11
	9	2.02	9	2.09	-	-
	SN 30/13 SAM104	2	2.05	2	2.06	1
3		2.08	3	2.03	2	2.03
4		2.05	4	2.03	3	2.01
5		2.06	5	2.02	4	2.03
6		2.08	6	2.02	5	2.03
7		2.06	7	2.04	6	2.00
8		2.07	8	2.04	7	1.98
9		2.07	9	2.05	-	-

4.2.5 Device Holder

The SAR in the phantom is approximately inversely proportional to the square of the distance between the source and the liquid surface. For a source at 5 mm distance, a positioning uncertainty of ± 0.5 mm would produce a SAR uncertainty of ± 20 %. Accurate device positioning is therefore crucial for accurate and repeatable measurements. The positions in which the devices must be measured are defined by the standards.



Serial Number	Holder Material	Permittivity	Loss Tangent
SN 25/13 MSH87	Deirin	3.7	0.005
SN 25/13 MSH88	Deirin	3.7	0.005

The positioning system allows obtaining cheek and tilting position with a very good accuracy. In compliance with CENELEC, the tilt angle uncertainty is lower than 1° .

4.2.6 Simulating Liquid

For SAR measurement of the field distribution inside the phantom, the phantom must be filled with homogeneous tissue simulating liquid to a depth of at least 15 cm. For head SAR testing, the liquid height from the ear reference point (ERP) of the phantom to the liquid top surface is larger than 15 cm. For body SAR testing, the liquid height from the center of the flat phantom to the liquid top surface is larger than 15 cm. The nominal dielectric values of the tissue simulating liquids in the phantom and the tolerance of 5%.

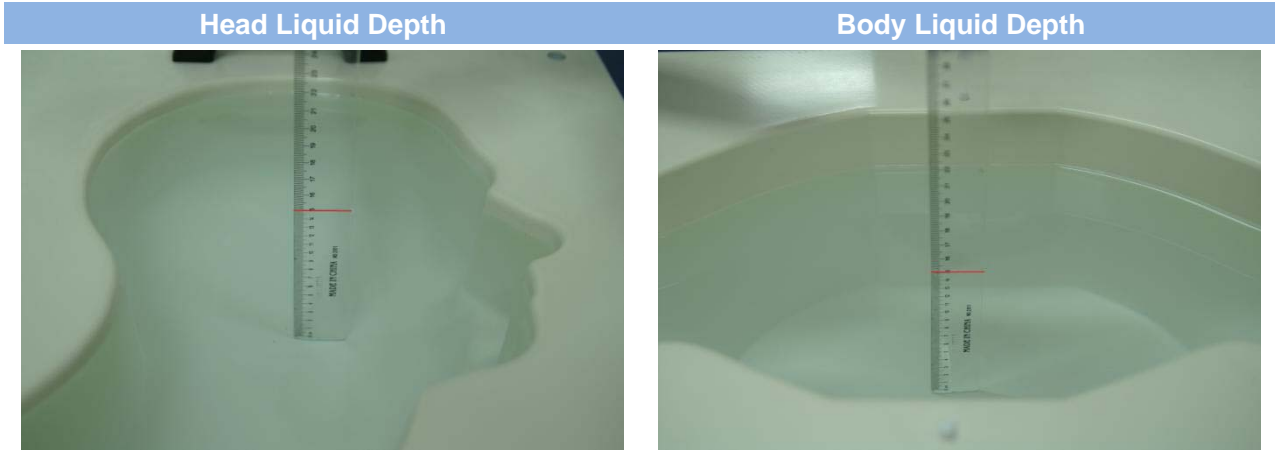

The following table gives the recipes for tissue simulating liquid and the theoretical Conductivity/Permittivity.

Head (Reference IEEE1528)								
Frequency (MHz)	Water (%)	Sugar (%)	Cellulose (%)	Salt (%)	Preventol (%)	DGBE (%)	Conductivity σ (S/m)	Permittivity ϵ
750	41.1	57.0	0.2	1.4	0.2	0	0.89	41.9
835	40.3	57.9	0.2	1.4	0.2	0	0.90	41.5
900	40.3	57.9	0.2	1.4	0.2	0	0.97	41.5
1800, 1900, 2000	55.2	0	0	0.3	0	44.5	1.4	40.0
2450	55.0	0	0	0.1	0	44.9	1.80	39.2
2600	54.9	0	0	0.1	0	45.0	1.96	39.0
Frequency(MHz)	Water (%)	Hexyl Carbitol (%)			Triton X-100 (%)		Conductivity σ (S/m)	Permittivity ϵ
5200	62.52	17.24			17.24		4.66	36.0
5800	62.52	17.24			17.24		5.27	35.3
Body (From instrument manufacturer)								
Frequency (MHz)	Water (%)	Sugar (%)	Cellulose (%)	Salt (%)	Preventol (%)	DGBE (%)	Conductivity σ (S/m)	Permittivity ϵ
750	51.7	47.2	0	0.9	0.1	0	0.96	55.5
835	50.8	48.2	0	0.9	0.1	0	0.97	55.2
900	50.8	48.2	0	0.9	0.1	0	1.05	55.0
1800, 1900, 2000	70.2	0	0	0.4	0	29.4	1.52	53.3
2450	68.6	0	0	0.1	0	31.3	1.95	52.7
2600	68.2	0	0	0.1	0	31.7	2.16	52.5

Frequency(MHz)	Water	DGBE (%)	Salt (%)	Conductivity σ (S/m)	Permittivity ϵ
5200	78.60	21.40	/	5.54	47.86
5800	78.50	21.40	0.1	6.0	48.20

5 SYSTEM VERIFICATION

5.1 Antenna Port Test Requirement

The SATIMO SAR system is equipped with one or more system validation kits. These units together with the predefined measurement procedures within the SATIMO software enable the user to conduct the system performance check and system validation. System validation kit includes a dipole, tripod holder to fix it underneath the flat phantom and a corresponding distance holder.

5.2 Purpose of System Check

The system performance check verifies that the system operates within its specifications. System and operator errors can be detected and corrected. It is recommended that the system performance check be performed prior to any usage of the system in order to guarantee reproducible results. The system performance check uses normal SAR measurements in a simplified setup with a well characterized source. This setup was selected to give a high sensitivity to all parameters that might fail or vary over time. The system check does not intend to replace the calibration of the components, but indicates situations where the system uncertainty is exceeded due to drift or failure.

5.3 System Check Setup

In the simplified setup for system evaluation, the EUT is replaced by a calibrated dipole and the power source is replaced by a continuous wave that comes from a signal generator. The calibrated dipole must be placed beneath the flat phantom section of the SAM twin phantom with the correct distance holder. The distance holder should touch the phantom surface with a light pressure at the reference marking and be oriented parallel to the long side of the phantom. The equipment setup is shown below:

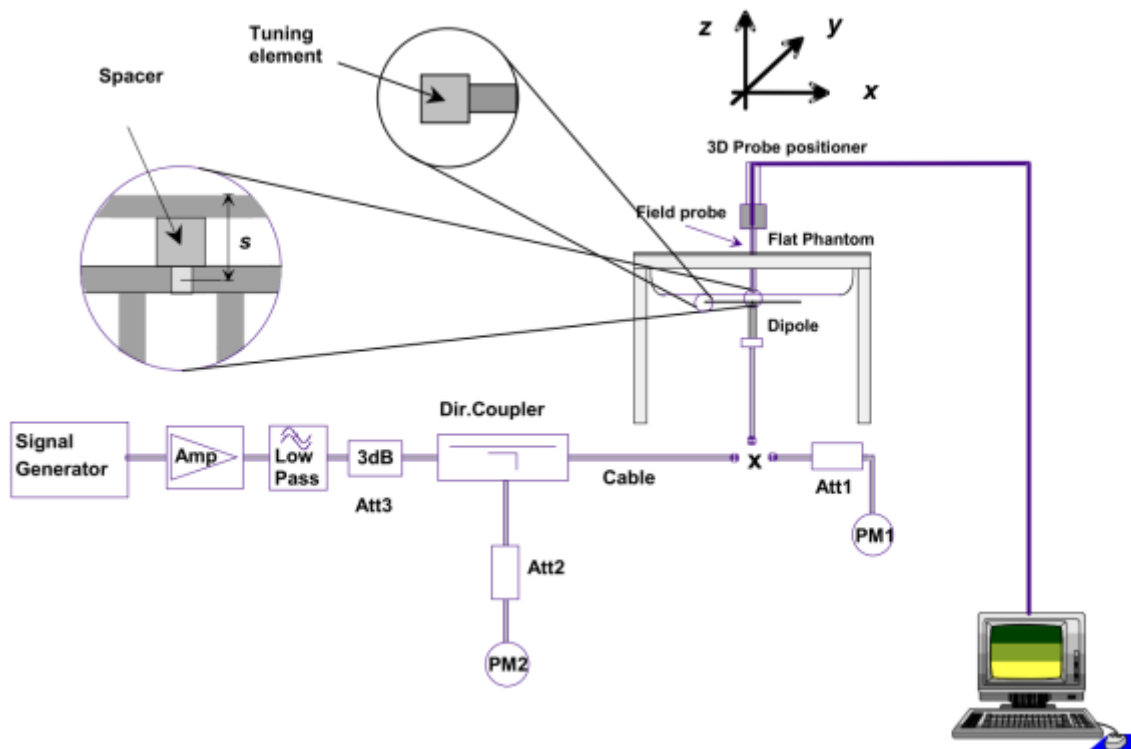

6 EUT TEST POSITION CONFIGURATIONS

According to handsets are tested for SAR compliance in head, body-worn accessory and other use configurations described in the following subsections.

6.1 Body-worn Position Conditions

Body-worn accessory exposure is typically related to voice mode operations when handsets are carried in body-worn accessories. The body-worn accessory procedures in KDB 447498 are used to test for body-worn accessory SAR compliance, without a headset connected to it. This enables the test results for such configuration to be compatible with that required for hotspot mode when the body-worn accessory test separation distance is greater than or equal to that required for hotspot mode. When the reported SAR for a body-worn accessory, measured without a headset connected to the handset, is $> 1.2 \text{ W/kg}$, the highest reported SAR configuration for that wireless mode and frequency band should be repeated for that body-worn accessory with a headset attached to the handset.

6.2 Hotspot Mode Exposure Position Conditions

For handsets that support hotspot mode operations, with wireless router capabilities and various web browsing functions, the relevant hand and body exposure conditions are tested according to the hotspot SAR procedures in KDB 941225. A test separation distance of 10 mm is required between the phantom and all surfaces and edges with a transmitting antenna located within 25 mm from that surface or edge. When the form factor of a handset is smaller than 9 cm x 5 cm, a test separation distance of 5 mm (instead of 10 mm) is required for testing hotspot mode. When the separation distance required for body-worn accessory testing is larger than or equal to that tested for hotspot mode, in the same wireless mode and for the same surface of the phone, the hotspot mode SAR data may be used to support body-worn accessory SAR compliance for that particular configuration (surface).

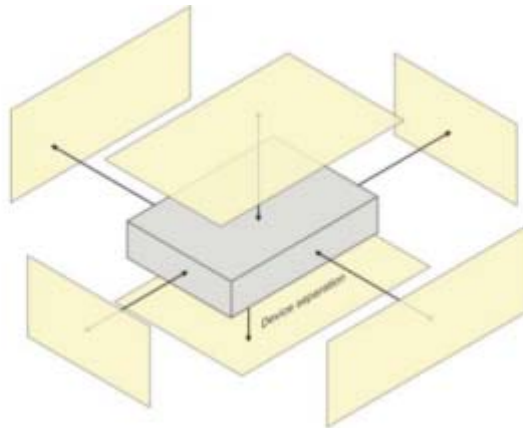

7 SAR MEASUREMENT PROCEDURES

7.1 SAR Measurement Process Diagram

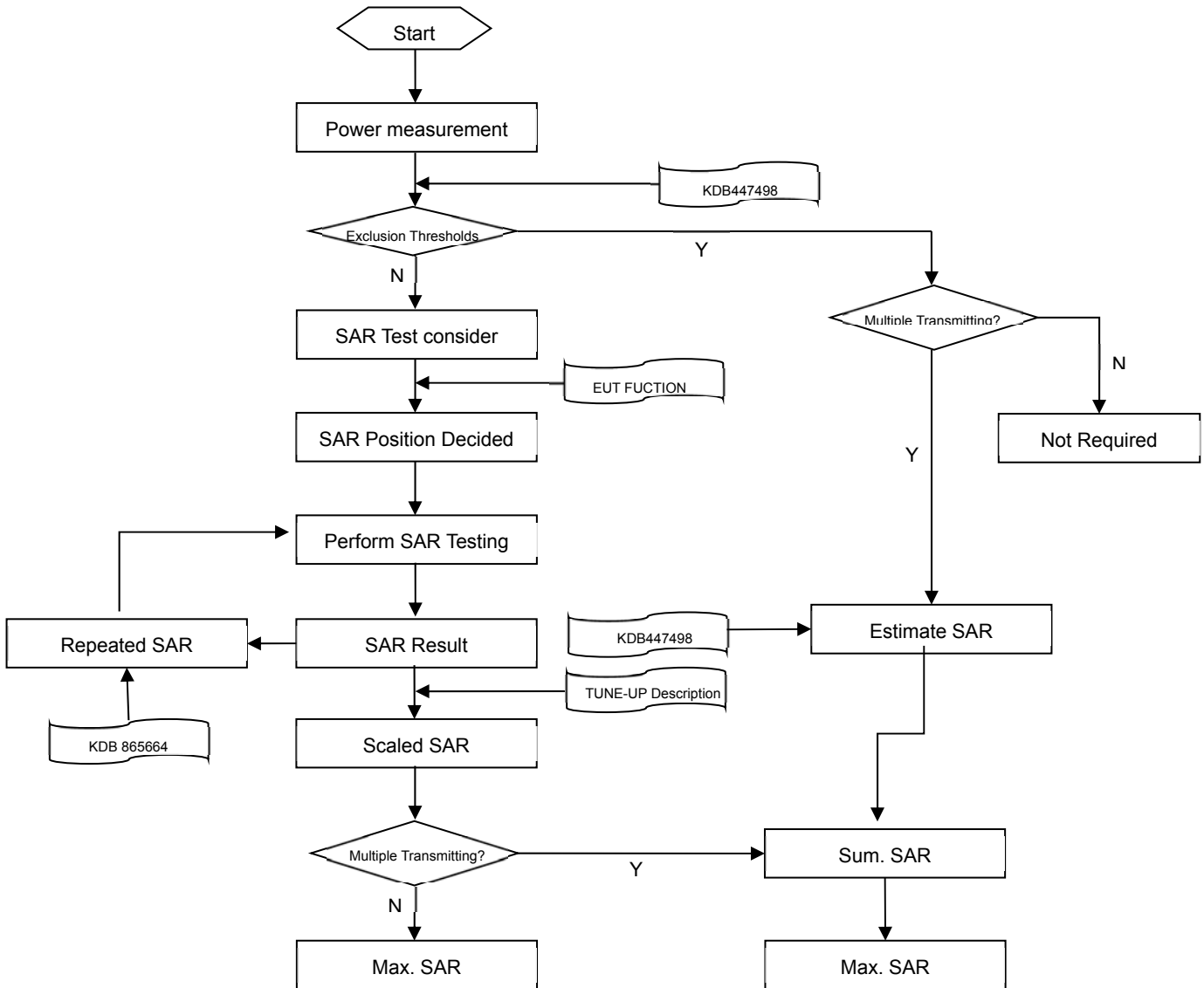

7.2 SAR Scan General Requirements

Probe boundary effect error compensation is required for measurements with the probe tip closer than half a probe tip diameter to the phantom surface. Both the probe tip diameter and sensor offset distance must satisfy measurement protocols; to ensure probe boundary effect errors are minimized and the higher fields closest to the phantom surface can be correctly measured and extrapolated to the phantom surface for computing 1-g SAR. Tolerances of the post-processing algorithms must be verified by the test laboratory for the scan resolutions used in the SAR measurements, according to the reference distribution functions specified in IEEE Std 1528-2013.

			≤3GHz	>3GHz
Maximum distance from closest measurement point (geometric center of probe sensors) to phantom surface			5±1 mm	$\frac{1}{2} \cdot \delta \cdot \ln(2) \pm 0.5$ mm
Maximum probe angle from probe axis to phantom surface normal at the measurement location			30°±1°	20°±1°
Maximum area scan spatial resolution: Δx Area , Δy Area			≤ 2 GHz: ≤ 15 mm 2 – 3 GHz: ≤ 12 mm	3–4 GHz: ≤ 12 mm 4 – 6 GHz: ≤ 10 mm
			When the x or y dimension of the test device, in the measurement plane orientation, is smaller than the above, the measurement resolution must be ≤ the corresponding x or y dimension of the test device with at least one measurement point on the test device.	
Maximum zoom scan spatial resolution: Δx Zoom , Δy Zoom			≤ 2 GHz: ≤ 8 mm 2 – 3 GHz: ≤ 5 mm*	3–4 GHz: ≤ 5 mm* 4 – 6 GHz: ≤ 4 mm*
Maximum zoom scan spatial resolution, normal to phantom surface	uniform grid: Δz Zoom (n)		≤ 5 mm	3–4 GHz: ≤ 4 mm
				4–5 GHz: ≤ 3 mm
				5–6 GHz: ≤ 2 mm
	graded grid	Δz Zoom (1): between 1st two points closest to phantom surface	≤ 4 mm	3–4 GHz: ≤ 3 mm
Δz Zoom (n>1): between subsequent points		4–5 GHz: ≤ 2.5 mm		
			5–6 GHz: ≤ 2 mm	
			≤ 1.5· Δz Zoom (n-1)	
Minimum zoom scan volume	x, y, z		≥30 mm	3–4 GHz: ≥ 28 mm
				4–5 GHz: ≥ 25 mm
				5–6 GHz: ≥ 22 mm

Note:

- δ is the penetration depth of a plane-wave at normal incidence to the tissue medium; see draft standard IEEE P1528-2011 for details.
- * When zoom scan is required and the reported SAR from the area scan based 1-g SAR estimation procedures of KDB 447498 is ≤ 1.4 W/kg, ≤ 8 mm, ≤ 7 mm and ≤ 5 mm zoom scan resolution may be applied, respectively, for 2 GHz to 3GHz, 3 GHz to 4 GHz and 4 GHz to 6 GHz.

7.3 SAR Measurement Procedure

The following steps are used for each test position

- Establish a call with the maximum output power with a base station simulator. The connection between the mobile and the base station simulator is established via air interface
- Measurement of the local E-field value at a fixed location. This value serves as a reference value for calculating a possible power drift.
- Measurement of the SAR distribution with a grid of 8 to 16mm * 8 to 16 mm and a constant distance to the inner surface of the phantom. Since the sensors cannot directly measure at the inner phantom surface, the values between the sensors and the inner phantom surface are extrapolated. With these values the area of the maximum SAR is calculated by an interpolation scheme.
- Around this point, a cube of 30 * 30 * 30 mm or 32 * 32 * 32 mm is assessed by measuring 5 or 8 * 5 or 8*4 or 5 mm. With these data, the peak spatial-average SAR value can be calculated.

7.4 Area & Zoom Scan Procedures

First Area Scan is used to locate the approximate location(s) of the local peak SAR value(s). The measurement grid within an Area Scan is defined by the grid extent, grid step size and grid offset. Next, in order to determine the EM field distribution in a three-dimensional spatial extension, Zoom Scan is required. The Zoom Scan is performed around the highest E-field value to determine the averaged SAR-distribution over 10 g. Area scan and zoom scan resolution setting follows KDB 865664 D01 quoted below.

When the 1-g SAR of the highest peak is within 2 dB of the SAR limit, additional zoom scans are required for other peaks within 2 dB of the highest peak that have not been included in any zoom scan to ensure there is no increase in SAR.

8 CONDUCTED RF OUPUT POWER

8.1 GSM

GSM 850								
GSM850 Band	Burst Average Power(dBm)			Tune-up Limit (dBm)	Frame-Averaged power (dBm)			Tune-up Limit (dBm)
Channel	128	190	251		128	190	251	
GSM (GMSK, 1-Slot)	32.24	32.41	32.50	33.00	23.05	23.22	23.31	23.81
GPRS (GMSK, 1-Slot)	32.25	32.40	32.47	33.00	23.06	23.21	23.28	23.81
GPRS (GMSK, 2-Slots)	31.52	31.64	31.73	32.00	25.39	25.51	25.60	25.87
GPRS (GMSK, 3-Slots)	29.81	30.01	30.09	30.50	25.39	25.59	25.67	26.08
GPRS (GMSK, 4-Slots)	28.76	28.90	29.05	29.50	25.58	25.72	25.87	26.32
EGPRS (8PSK, 1-Slot)	29.23	29.16	29.17	29.50	20.04	19.97	19.98	20.31
EGPRS (8PSK, 2-Slots)	28.27	28.24	28.17	28.50	22.14	22.11	22.04	22.37
EGPRS (8PSK, 3-Slots)	26.56	26.42	26.51	27.00	22.14	22.00	22.09	22.58
EGPRS (8PSK, 4-Slots)	25.59	25.54	25.53	26.00	22.41	22.36	22.35	22.82
GSM 1900								
GSM1900 Band	Burst Average Power(dBm)			Tune-up Limit (dBm)	Frame-Averaged power(dBm)			Tune-up Limit (dBm)
Channel	512	661	810		512	661	810	
GSM (GMSK, 1-Slot)	29.23	29.16	29.17	30.00	20.04	19.97	19.98	20.81
GPRS (GMSK, 1-Slot)	29.64	29.47	29.14	30.00	20.45	20.28	19.95	20.81
GPRS (GMSK, 2-Slots)	28.88	28.72	28.41	29.00	22.75	22.59	22.28	22.87
GPRS (GMSK, 3-Slots)	27.14	26.99	26.73	27.50	22.72	22.57	22.31	23.08
GPRS (GMSK, 4-Slots)	26.12	25.94	25.70	26.50	22.94	22.76	22.52	23.32
EGPRS (8PSK, 1-Slot)	29.57	27.85	27.08	30.00	20.38	18.66	17.89	20.81
EGPRS (8PSK, 2-Slots)	28.73	27.07	26.11	29.00	22.60	20.94	19.98	22.87
EGPRS (8PSK, 3-Slots)	26.81	24.92	23.75	27.50	22.39	20.50	19.33	23.08
EGPRS (8PSK, 4-Slots)	25.41	23.62	22.34	26.00	22.23	20.44	19.16	22.82

Note¹: SAR testing was performed on the maximum frame-averaged power mode.

Note²: The frame-averaged power is linearly proportion to the slot number configured and it is linearly scaled the maximum burst-averaged power based on time slots. The calculated method is shown as below:

- Frame-averaged power = Burst averaged power (1 Tx Slot) – 9.19 dB
- Frame-averaged power = Burst averaged power (2 Tx Slots) – 6.13 dB
- Frame-averaged power = Burst averaged power (3 Tx Slots) - 4.42dB
- Frame-averaged power = Burst averaged power (4 Tx Slots) – 3.18 dB

8.2 WCDMA

WCDMA	Band 2				Band 4			
Channel	9262	9400	9538	Tune-up Limit (dBm)	1312	1412	1513	Tune-up Limit (dBm)
RMC 12.2Kbps	21.89	21.94	21.85	22.50	22.14	22.16	22.19	22.50
HSDPA Subtest-1	20.89	20.91	20.94	21.50	21.15	21.23	21.18	21.50
HSDPA Subtest-2	20.90	20.87	20.84	21.50	21.13	21.16	21.22	21.50
HSDPA Subtest-3	20.41	20.39	20.37	21.00	20.66	20.70	20.71	21.00
HSDPA Subtest-4	20.43	20.40	20.33	21.00	20.63	20.69	20.67	21.00
HSUPA Subtest-1	19.16	19.17	19.10	20.00	19.29	19.34	19.38	20.00
HSUPA Subtest-2	19.16	19.18	19.12	20.00	19.31	19.37	19.33	20.00
HSUPA Subtest-3	20.10	20.12	20.12	20.50	20.26	20.29	20.32	20.50
HSUPA Subtest-4	18.65	18.69	18.69	19.00	18.82	18.86	18.87	19.00
HSUPA Subtest-5	20.09	20.08	20.10	20.50	20.21	20.26	20.29	20.50
WCDMA	Band 5				-			
Channel	4132	4182	4233	Tune-up Limit (dBm)	-	-	-	-
RMC 12.2Kbps	22.14	22.00	22.07	22.50	-	-	-	-
HSDPA Subtest-1	21.16	21.05	21.32	21.50	-	-	-	-
HSDPA Subtest-2	21.11	21.01	21.25	21.50	-	-	-	-
HSDPA Subtest-3	20.62	20.49	20.74	21.00	-	-	-	-
HSDPA Subtest-4	20.61	20.48	20.72	21.00	-	-	-	-
HSUPA Subtest-1	19.35	19.21	19.25	20.00	-	-	-	-
HSUPA Subtest-2	19.33	19.21	19.26	20.00	-	-	-	-
HSUPA Subtest-3	20.28	20.17	20.27	20.50	-	-	-	-
HSUPA Subtest-4	18.89	18.81	18.85	19.00	-	-	-	-
HSUPA Subtest-5	20.27	20.21	20.25	20.50	-	-	-	-

8.3 LTE

FDD LTE Band 2									
Bandwidth (MHz)	RB Set	Power (dBm)							
		QPSK			Tune up limit (dBm)	16QAM			Tune up limit (dBm)
	Channel	18700	18900	19100		18700	18900	19100	
20 MHz	1 (RB_Pos:0)	22.57	22.54	22.39	23.50	21.94	21.77	21.63	22.00
	1 (RB_Pos:50)	22.99	22.99	22.88	23.50	22.37	22.07	22.09	22.00
	1 (RB_Pos:99)	22.48	22.40	22.53	23.50	21.84	21.60	21.65	22.00
	50 (RB_Pos:0)	21.68	21.69	21.72	22.00	20.75	20.67	20.70	21.00
	50 (RB_Pos:25)	21.80	21.71	21.76	22.00	20.81	20.68	20.74	21.00
	50 (RB_Pos:50)	21.79	21.63	21.69	22.00	20.80	20.63	20.63	21.00
	100 (RB_Pos:0)	21.74	21.69	21.71	22.00	20.80	20.66	20.74	21.00
Bandwidth (MHz)	RB Set	Power (dBm)							
		QPSK			Tune up limit (dBm)	16QAM			Tune up limit (dBm)
	Channel	18675	18900	19125		18675	18900	19125	
15 MHz	1 (RB_Pos:0)	22.70	22.71	22.66	23.00	21.51	21.87	21.84	22.00
	1 (RB_Pos:38)	22.79	22.85	22.85	23.00	21.61	21.95	22.00	22.00
	1 (RB_Pos:74)	22.62	22.59	22.82	23.00	21.45	21.73	21.78	22.00
	36 (RB_Pos:0)	21.79	21.88	21.85	22.00	20.80	20.82	20.81	21.00
	36 (RB_Pos:20)	21.84	21.87	21.89	22.00	20.84	20.83	20.83	21.00
	36 (RB_Pos:39)	21.84	21.80	21.89	22.00	20.82	20.79	20.80	21.00
	75 (RB_Pos:0)	21.85	21.88	21.89	22.00	20.82	20.82	20.83	21.00
Bandwidth (MHz)	RB Set	Power (dBm)							
		QPSK			Tune up limit (dBm)	16QAM			Tune up limit (dBm)
	Channel	18650	18900	19150		18650	18900	19150	
10 MHz	1 (RB_Pos:0)	22.75	22.79	22.79	23.50	21.54	21.93	21.62	22.00
	1 (RB_Pos:25)	22.89	22.90	23.05	23.50	21.73	22.07	21.81	22.00
	1 (RB_Pos:49)	22.71	22.72	22.92	23.50	21.52	21.84	21.58	22.00
	25 (RB_Pos:0)	21.70	21.76	21.82	22.00	20.79	20.75	20.86	21.00
	25 (RB_Pos:12)	21.77	21.75	21.78	22.00	20.81	20.71	20.85	21.00
	25 (RB_Pos:25)	21.80	21.73	21.77	22.00	20.82	20.72	20.84	21.00
	50 (RB_Pos:0)	21.78	21.71	21.78	22.00	20.79	20.70	20.78	21.00
Bandwidth (MHz)	RB Set	Power (dBm)							
		QPSK			Tune up limit (dBm)	16QAM			Tune up limit (dBm)
	Channel	18625	18900	19175		18625	18900	19175	
5 MHz	1 (RB_Pos:0)	22.61	22.73	22.71	23.00	21.69	21.99	21.68	22.00
	1 (RB_Pos:13)	22.69	22.80	22.89	23.00	21.78	22.06	21.77	22.00
	1 (RB_Pos:24)	22.63	22.68	22.81	23.00	21.68	21.95	21.69	22.00
	12 (RB_Pos:0)	21.64	21.70	21.76	22.00	20.74	20.80	20.79	21.00
	12 (RB_Pos:6)	21.70	21.71	21.81	22.00	20.80	20.82	20.84	21.00

	12 (RB_Pos:13)	21.65	21.63	21.72	22.00	20.77	20.77	20.75	21.00
	25 (RB_Pos:0)	21.65	21.66	21.73	22.00	20.71	20.70	20.68	21.00
Bandwidth (MHz)	RB Set	Power (dBm)							
		QPSK			Tune up limit (dBm)	16QAM			Tune up limit (dBm)
	Channel	18615	18900	19185		18615	18900	19185	
3.0 MHz	1 (RB_Pos:0)	22.67	22.75	22.91	23.00	21.49	21.87	21.67	22.00
	1 (RB_Pos:8)	22.62	22.73	22.91	23.00	21.45	21.88	21.60	22.00
	1 (RB_Pos:14)	22.58	22.72	22.98	23.00	21.46	21.87	21.61	22.00
	8 (RB_Pos:0)	21.67	21.74	21.86	22.00	20.75	20.75	20.79	21.00
	8 (RB_Pos:3)	21.65	21.79	21.82	22.00	20.74	20.77	20.83	21.00
	8 (RB_Pos:7)	21.61	21.73	21.84	22.00	20.70	20.67	20.77	21.00
	15 (RB_Pos:0)	21.57	21.65	21.76	22.00	20.64	20.63	20.71	21.00
Bandwidth (MHz)	RB Set	Power (dBm)							
		QPSK			Tune up limit (dBm)	16QAM			Tune up limit (dBm)
	Channel	18607	18900	19193		18607	18900	19193	
1.4 MHz	1 (RB_Pos:0)	23.13	23.22	22.78	23.50	22.07	22.30	21.54	22.50
	1 (RB_Pos:3)	23.33	23.34	22.95	23.50	22.23	22.40	21.63	22.50
	1 (RB_Pos:5)	23.13	23.21	22.81	23.50	22.10	22.12	21.54	22.50
	3 (RB_Pos:0)	23.15	23.04	22.65	23.50	22.09	21.91	21.70	22.50
	3 (RB_Pos:1)	23.12	23.13	22.73	23.50	22.13	21.78	21.72	22.50
	3 (RB_Pos:3)	23.13	23.02	22.67	23.50	22.04	21.66	21.67	22.50
	6 (RB_Pos:0)	22.16	22.30	21.83	22.50	21.23	20.59	20.85	22.00

FDD LTE Band 4									
Bandwidth (MHz)	RB Set	Power (dBm)							
		QPSK			Tune up limit (dBm)	16QAM			Tune up limit (dBm)
	Channel	20050	20175	20300		20050	20175	20300	
20 MHz	1 (RB_Pos:0)	22.52	22.60	22.51	23.50	22.01	22.01	21.87	22.50
	1 (RB_Pos:50)	22.96	22.97	22.93	23.50	22.46	22.34	22.22	22.50
	1 (RB_Pos:99)	22.48	22.51	22.44	23.50	21.95	21.84	21.72	22.50
	50 (RB_Pos:0)	21.73	21.77	21.78	22.50	20.75	20.76	20.72	21.50
	50 (RB_Pos:25)	21.85	21.84	21.84	22.50	20.84	20.83	20.78	21.50
	50 (RB_Pos:50)	21.83	21.84	21.65	22.50	20.80	20.86	20.63	21.50
	100 (RB_Pos:0)	21.81	21.78	21.77	22.50	20.78	20.78	20.71	21.50
Bandwidth (MHz)	RB Set	Power (dBm)							
		QPSK			Tune up limit (dBm)	16QAM			Tune up limit (dBm)
	Channel	19275	19575	19875		19275	19575	19875	
15 MHz	1 (RB_Pos:0)	22.69	22.75	22.72	23.50	21.61	22.09	22.04	22.50
	1 (RB_Pos:38)	22.73	22.82	22.87	23.50	21.69	22.09	22.06	22.50
	1 (RB_Pos:74)	22.64	22.63	22.67	23.50	21.52	21.95	21.96	22.50

	36 (RB_Pos:0)	21.84	21.85	21.96	22.50	20.82	20.91	20.84	21.50
	36 (RB_Pos:20)	21.84	21.92	21.90	22.50	20.83	20.92	20.88	21.50
	36 (RB_Pos:39)	21.85	21.97	21.78	22.50	20.85	20.95	20.74	21.50
	75 (RB_Pos:0)	21.87	21.93	21.87	22.50	20.82	20.85	20.83	21.50
Bandwidth (MHz)	RB Set	Power (dBm)							
		QPSK			Tune up limit (dBm)	16QAM			Tune up limit (dBm)
	Channel	19250	19575	19900		19250	19575	19900	
10 MHz	1 (RB_Pos:0)	22.74	22.80	22.77	23.50	21.69	22.14	21.74	22.50
	1 (RB_Pos:25)	22.98	22.94	22.98	23.50	21.76	22.19	21.86	22.50
	1 (RB_Pos:49)	22.71	22.71	22.76	23.50	21.68	22.02	21.64	22.50
	25 (RB_Pos:0)	21.84	21.85	21.81	22.50	20.82	20.81	20.93	21.50
	25 (RB_Pos:12)	21.81	21.85	21.76	22.50	20.82	20.84	20.90	21.50
	25 (RB_Pos:25)	21.84	21.86	21.69	22.50	20.82	20.86	20.79	21.50
	50 (RB_Pos:0)	21.80	21.85	21.73	22.50	20.79	20.84	20.82	21.50
Bandwidth (MHz)	RB Set	Power (dBm)							
		QPSK			Tune up limit (dBm)	16QAM			Tune up limit (dBm)
	Channel	19225	19575	19925		19225	19575	19925	
5 MHz	1 (RB_Pos:0)	22.65	22.68	22.65	23.50	21.82	22.14	21.68	22.50
	1 (RB_Pos:13)	22.78	22.81	22.83	23.50	21.95	22.27	21.84	22.50
	1 (RB_Pos:24)	22.63	22.66	22.66	23.50	21.78	22.11	21.71	22.50
	12 (RB_Pos:0)	21.77	21.74	21.74	22.50	20.80	20.88	20.82	21.50
	12 (RB_Pos:6)	21.80	21.83	21.78	22.50	20.85	20.94	20.88	21.50
	12 (RB_Pos:13)	21.72	21.77	21.67	22.50	20.75	20.91	20.80	21.50
	25 (RB_Pos:0)	21.75	21.77	21.71	22.50	20.75	20.82	20.71	21.50
Bandwidth (MHz)	RB Set	Power (dBm)							
		QPSK			Tune up limit (dBm)	16QAM			Tune up limit (dBm)
	Channel	19215	19575	19935		19215	19575	19935	
3.0 MHz	1 (RB_Pos:0)	22.78	22.79	22.77	23.50	21.68	22.09	21.67	22.50
	1 (RB_Pos:8)	22.70	22.78	22.80	23.50	21.65	22.12	21.70	22.50
	1 (RB_Pos:14)	22.67	22.75	22.77	23.50	21.62	22.08	21.66	22.50
	8 (RB_Pos:0)	21.80	21.85	21.77	22.50	20.86	20.85	20.83	21.50
	8 (RB_Pos:3)	21.84	21.89	21.84	22.50	20.83	20.89	20.87	21.50
	8 (RB_Pos:7)	21.79	21.85	21.75	22.50	20.85	20.81	20.83	21.50
	15 (RB_Pos:0)	21.75	21.82	21.77	22.50	20.74	20.80	20.72	21.50
Bandwidth (MHz)	RB Set	Power (dBm)							
		QPSK			Tune up limit (dBm)	16QAM			Tune up limit (dBm)
	Channel	19207	19575	19943		19207	19575	19943	
1.4 MHz	1 (RB_Pos:0)	22.70	22.75	22.73	23.50	21.85	22.06	21.67	22.50
	1 (RB_Pos:3)	22.89	22.91	22.98	23.50	21.99	22.24	21.84	22.50
	1 (RB_Pos:5)	22.74	22.74	22.75	23.50	21.79	22.03	21.68	22.50
	3 (RB_Pos:0)	22.74	22.74	22.80	23.50	21.81	21.94	21.91	22.50

	3 (RB_Pos:1)	22.75	22.79	22.83	23.50	21.82	21.92	21.94	22.50
	3 (RB_Pos:3)	22.73	22.72	22.80	23.50	21.79	21.91	21.91	22.50
	6 (RB_Pos:0)	21.79	21.85	21.80	22.50	20.91	20.70	20.95	21.50

FDD LTE Band 5									
Bandwidth (MHz)	RB Set	Power (dBm)							
		QPSK			Tune up limit (dBm)	16QAM			Tune up limit (dBm)
	Channel	20450	20525	20600		20450	20525	20600	
10 MHz	1 (RB_Pos:0)	23.09	23.12	23.05	23.50	21.95	22.37	22.00	22.50
	1 (RB_Pos:25)	23.17	23.19	23.14	23.50	22.12	22.49	22.11	22.50
	1 (RB_Pos:49)	22.97	23.01	23.02	23.50	21.95	22.30	21.99	22.50
	25 (RB_Pos:0)	22.08	22.16	21.98	22.50	21.13	21.10	21.03	21.50
	25 (RB_Pos:12)	22.08	22.10	22.07	22.50	21.12	21.11	21.07	21.50
	25 (RB_Pos:25)	21.95	22.21	21.93	22.50	21.00	21.24	20.95	21.50
	50 (RB_Pos:0)	22.06	22.18	21.95	22.50	21.08	21.15	20.93	21.50
Bandwidth (MHz)	RB Set	Power (dBm)							
		QPSK			Tune up limit (dBm)	16QAM			Tune up limit (dBm)
	Channel	20425	20525	20625		20425	20525	20625	
5MHz	1 (RB_Pos:0)	22.98	23.01	22.93	23.50	22.09	22.44	21.99	22.50
	1 (RB_Pos:13)	23.07	23.09	23.03	23.50	22.19	22.50	22.10	22.50
	1 (RB_Pos:24)	22.91	22.96	22.94	23.50	22.04	22.37	21.98	22.50
	12 (RB_Pos:0)	22.00	21.96	22.06	22.50	21.11	21.10	21.10	21.50
	12 (RB_Pos:6)	22.01	22.06	22.03	22.50	21.11	21.20	21.07	21.50
	12 (RB_Pos:13)	21.97	22.06	21.94	22.50	21.02	21.19	20.99	21.50
	25 (RB_Pos:0)	21.99	22.06	22.02	22.50	21.02	21.06	20.94	21.50
Bandwidth (MHz)	RB Set	Power (dBm)							
		QPSK			Tune up limit (dBm)	16QAM			Tune up limit (dBm)
	Channel	20415	20525	20635		20415	20525	20635	
3.0 MHz	1 (RB_Pos:0)	23.04	23.08	23.04	23.50	21.94	22.38	22.04	22.50
	1 (RB_Pos:8)	23.00	23.03	23.05	23.50	21.91	22.36	22.00	22.50
	1 (RB_Pos:14)	23.01	23.01	23.01	23.50	21.87	22.32	21.93	22.50
	8 (RB_Pos:0)	22.01	22.01	22.05	22.50	21.13	21.08	21.02	21.50
	8 (RB_Pos:3)	22.06	22.08	22.09	22.50	21.16	21.13	21.07	21.50
	8 (RB_Pos:7)	22.00	22.03	22.01	22.50	21.10	21.05	20.98	21.50
	15 (RB_Pos:0)	22.00	22.00	22.00	22.50	21.06	21.00	20.95	21.50
Bandwidth (MHz)	RB Set	Power (dBm)							
		QPSK			Tune up limit (dBm)	16QAM			Tune up limit (dBm)
	Channel	20407	20525	20643		20407	20525	20643	
1.4MHz	1 (RB_Pos:0)	23.02	23.04	23.03	23.50	22.09	22.34	21.97	22.50
	1 (RB_Pos:3)	23.18	23.15	23.21	23.50	22.27	22.48	22.16	22.50

	1 (RB_Pos:5)	22.99	23.01	23.00	23.50	22.08	22.32	21.97	22.50
	3 (RB_Pos:0)	23.07	23.02	23.06	23.50	22.07	22.19	22.17	22.50
	3 (RB_Pos:1)	23.12	23.08	23.10	23.50	22.11	22.22	22.23	22.50
	3 (RB_Pos:3)	23.03	23.01	23.07	23.50	22.06	22.19	22.17	22.50
	6 (RB_Pos:0)	22.09	22.08	22.07	22.50	21.24	20.95	21.20	21.50

FDD LTE Band 7									
Bandwidth (MHz)	RB Set	Power (dBm)							
		QPSK			Tune up limit (dBm)	16QAM			Tune up limit (dBm)
	Channel	20850	21100	21350		20850	21100	21350	
20MHz	1 (RB_Pos:0)	21.79	22.14	21.09	23.00	21.80	22.22	20.98	22.50
	1 (RB_Pos:50)	21.70	21.27	21.31	23.00	21.94	21.54	21.33	22.50
	1 (RB_Pos:99)	22.32	21.11	20.97	23.00	22.39	21.38	21.06	22.50
	50 (RB_Pos:0)	21.44	21.55	21.00	22.50	21.42	21.33	20.84	22.00
	50 (RB_Pos:25)	21.58	21.23	21.09	22.50	21.45	21.29	20.96	22.00
	50 (RB_Pos:50)	21.93	21.09	21.07	22.50	21.39	21.16	20.95	22.00
	100 (RB_Pos:0)	21.64	21.30	20.95	22.50	21.45	21.23	20.88	21.50
Bandwidth (MHz)	RB Set	Power (dBm)							
		QPSK			Tune up limit (dBm)	16QAM			Tune up limit (dBm)
	Channel	20825	21100	21375		20825	21100	21375	
15MHz	1 (RB_Pos:0)	22.06	22.14	21.51	23.00	21.55	22.26	21.31	22.50
	1 (RB_Pos:38)	21.68	21.38	21.33	23.00	21.37	21.63	21.27	22.50
	1 (RB_Pos:74)	22.24	21.35	21.22	23.00	21.99	21.62	21.18	22.50
	36 (RB_Pos:0)	21.61	21.64	21.25	22.50	21.45	21.35	21.08	22.00
	36 (RB_Pos:20)	21.58	21.36	21.17	22.50	21.42	21.30	21.02	22.00
	36 (RB_Pos:39)	21.87	21.28	21.15	22.50	21.41	21.22	21.03	22.00
	75 (RB_Pos:0)	21.68	21.45	21.12	22.50	21.46	21.27	21.02	21.50
Bandwidth (MHz)	RB Set	Power (dBm)							
		QPSK			Tune up limit (dBm)	16QAM			Tune up limit (dBm)
	Channel	20800	21100	21400		20800	21100	21400	
10MHz	1 (RB_Pos:0)	22.12	21.95	21.63	23.00	21.61	22.08	21.14	22.50
	1 (RB_Pos:25)	21.59	21.39	21.23	23.00	21.29	21.62	20.88	22.50
	1 (RB_Pos:49)	21.90	21.36	21.16	23.00	21.65	21.63	20.85	22.50
	25 (RB_Pos:0)	21.67	21.56	21.22	22.50	21.42	21.31	21.13	22.00
	25 (RB_Pos:12)	21.55	21.35	21.10	22.50	21.40	21.25	21.04	22.00
	25 (RB_Pos:25)	21.63	21.30	21.06	22.50	21.39	21.21	21.02	22.00
	50 (RB_Pos:0)	21.57	21.39	21.09	22.50	21.41	21.28	21.02	21.50
Bandwidth (MHz)	RB Set	Power (dBm)							
		QPSK			Tune up limit (dBm)	16QAM			Tune up limit (dBm)
	Channel	20775	21100	21425		20775	21100	21425	

5MHz	1 (RB_Pos:0)	22.52	22.07	21.63	23.00	22.09	22.22	21.15	22.50
	1 (RB_Pos:13)	22.22	21.82	21.45	23.00	21.98	22.08	21.12	22.50
	1 (RB_Pos:24)	22.02	21.67	21.26	23.00	21.89	22.00	21.00	22.50
	12 (RB_Pos:0)	22.08	21.71	21.26	22.50	21.38	21.30	21.10	22.00
	12 (RB_Pos:6)	21.99	21.63	21.22	22.50	21.41	21.30	21.09	22.00
	12 (RB_Pos:13)	21.86	21.55	21.13	22.50	21.36	21.22	21.02	22.00
	25 (RB_Pos:0)	21.92	21.61	21.14	22.50	21.33	21.19	20.98	21.50

FDD LTE Band 12									
Bandwidth (MHz)	RB Set	Power (dBm)							
		QPSK			Tune up limit (dBm)	16QAM			Tune up limit (dBm)
	Channel	23060	23095	23130		23060	23095	23130	
10 MHz	1 (RB_Pos:0)	22.88	22.89	22.93	23.50	21.80	22.23	21.94	22.50
	1 (RB_Pos:25)	23.07	23.07	22.99	23.50	21.96	22.42	22.07	22.50
	1 (RB_Pos:49)	22.87	22.84	22.87	23.50	21.84	22.26	21.88	22.50
	25 (RB_Pos:0)	22.17	22.09	21.80	22.50	21.15	21.11	20.89	21.50
	25 (RB_Pos:12)	21.99	21.98	21.94	22.50	20.98	21.01	20.98	21.50
	25 (RB_Pos:25)	22.04	22.19	21.76	22.50	21.03	21.20	20.82	21.50
	50 (RB_Pos:0)	22.08	22.13	21.78	22.50	21.06	21.18	20.77	21.50
Bandwidth (MHz)	RB Set	Power (dBm)							
		QPSK			Tune up limit (dBm)	16QAM			Tune up limit (dBm)
	Channel	23035	23095	23155		23035	23095	23155	
5MHz	1 (RB_Pos:0)	22.81	22.86	22.75	23.50	21.98	22.32	21.90	22.50
	1 (RB_Pos:13)	22.86	22.91	22.84	23.50	22.04	22.47	21.94	22.50
	1 (RB_Pos:24)	22.82	22.80	22.78	23.50	22.00	22.31	21.90	22.50
	12 (RB_Pos:0)	21.89	21.91	21.94	22.50	20.95	21.05	21.01	21.50
	12 (RB_Pos:6)	21.93	21.97	21.92	22.50	20.98	21.12	20.99	21.50
	12 (RB_Pos:13)	21.78	21.97	21.82	22.50	20.81	21.12	20.85	21.50
	25 (RB_Pos:0)	21.86	21.96	21.87	22.50	20.84	21.04	20.81	21.50
Bandwidth (MHz)	RB Set	Power (dBm)							
		QPSK			Tune up limit (dBm)	16QAM			Tune up limit (dBm)
	Channel	23025	23095	23165		23025	23095	23165	
3.0 MHz	1 (RB_Pos:0)	22.88	22.91	22.87	23.50	21.82	22.30	21.88	22.50
	1 (RB_Pos:8)	22.83	22.95	22.86	23.50	21.80	22.35	21.83	22.50
	1 (RB_Pos:14)	22.83	22.88	22.93	23.50	21.75	22.28	21.85	22.50
	8 (RB_Pos:0)	21.91	21.95	21.92	22.50	21.00	21.04	20.92	21.50
	8 (RB_Pos:3)	21.94	21.99	21.96	22.50	21.04	21.05	20.98	21.50
	8 (RB_Pos:7)	21.89	21.95	21.94	22.50	20.97	21.01	20.92	21.50
	15 (RB_Pos:0)	21.92	21.95	21.91	22.50	20.91	20.97	20.81	21.50
Bandwidth (MHz)	RB Set	Power (dBm)							
		QPSK			Tune	16QAM			Tune

	Channel	23017	23095	23173	up limit (dBm)	23017	23095	23173	up limit (dBm)
1.4MHz	1 (RB_Pos:0)	22.84	22.82	22.78	23.50	21.94	22.22	21.76	22.50
	1 (RB_Pos:3)	22.98	22.99	22.98	23.50	22.11	22.34	21.95	22.50
	1 (RB_Pos:5)	22.80	22.83	22.82	23.50	21.91	22.21	21.85	22.50
	3 (RB_Pos:0)	22.87	22.88	22.84	23.50	21.95	22.13	21.98	22.50
	3 (RB_Pos:1)	22.90	22.92	22.90	23.50	21.95	22.10	22.07	22.50
	3 (RB_Pos:3)	22.83	22.86	22.88	23.50	21.85	22.10	22.07	22.50
	6 (RB_Pos:0)	21.95	21.97	21.91	22.50	21.05	20.84	21.04	21.50

FDD LTE Band 17									
Bandwidth (MHz)	RB Set	Power (dBm)							
		QPSK			Tune up limit (dBm)	16QAM			Tune up limit (dBm)
	Channel	23780	23790	23800		23780	23790	23800	
10 MHz	1 (RB_Pos:0)	22.95	22.97	23.01	23.50	21.89	22.38	22.04	22.50
	1 (RB_Pos:25)	23.00	23.10	23.09	23.50	22.00	22.44	22.08	22.50
	1 (RB_Pos:49)	22.81	22.86	22.95	23.50	21.72	22.20	21.95	22.50
	25 (RB_Pos:0)	22.01	21.93	21.87	22.50	21.05	20.95	20.95	21.50
	25 (RB_Pos:12)	22.04	21.98	21.99	22.50	21.03	21.00	21.04	21.50
	25 (RB_Pos:25)	22.05	21.92	21.82	22.50	21.06	20.92	20.85	21.50
	50 (RB_Pos:0)	22.03	21.90	21.85	22.50	21.01	20.93	20.84	21.50
Bandwidth (MHz)	RB Set	Power (dBm)							
		QPSK			Tune up limit (dBm)	16QAM			Tune up limit (dBm)
	Channel	23755	23790	23825		23755	23790	23825	
5MHz	1 (RB_Pos:0)	22.87	22.84	22.82	23.50	21.99	22.40	21.95	22.50
	1 (RB_Pos:13)	22.96	22.94	22.90	23.50	22.11	22.46	21.95	22.50
	1 (RB_Pos:24)	22.85	22.79	22.84	23.50	22.01	22.28	21.95	22.50
	12 (RB_Pos:0)	21.98	21.86	21.96	22.50	21.06	21.02	20.99	22.50
	12 (RB_Pos:6)	22.05	22.00	21.96	22.50	21.10	21.13	21.01	21.50
	12 (RB_Pos:13)	21.98	21.94	21.82	22.50	21.09	21.13	20.86	21.50
	25 (RB_Pos:0)	22.00	21.93	21.90	22.50	21.02	20.98	20.85	21.50

8.4 WIFI

8.4.1 2.4GWIFI

Band (GHz)	Mode	Channel	Freq. (MHz)	Conducted Power (dBm)	Tune-up Limit (dBm)	SAR Test Require.
2.4 (2.4~2.4835)	802.11b	1	2412	14.93	15.5	Yes
		6	2437	15.03	15.5	Yes
		11	2462	14.68	15.5	Yes
	802.11g	1	2412	16.29	18.5	No
		6	2437	18.13	18.5	No
		11	2462	17.93	18.5	No
	802.11n(HT20)	1	2412	16.33	18.5	No
		6	2437	18.36	18.5	No
		11	2462	17.76	18.5	No
	802.11n(HT40)	3	2422	18.14	18.5	No
		6	2437	17.85	18.5	No
		9	2452	17.55	18.5	No

8.5 Bluetooth

Mode	GFSK			π/4-DQPSK		
Channel	0	39	78	0	39	78
Frequency (MHz)	2402	2441	2480	2402	2441	2480
Conducted Power (dBm)	-0.76	0.16	0.94	-1.26	-0.43	0.21
Tune-Up Limit (dBm)	1.00			0.50		
Mode	8-DPSK			BLE		
Channel	0	39	78	0	19	39
Frequency (MHz)	2402	2441	2480	2402	2440	2480
Conducted Power (dBm)	-1.1	-0.25	0.38	-0.82	0.17	0.75
Tune-Up Limit (dBm)	0.50			1.00		

9 EUT ANTENNA LOCATION SKETCH

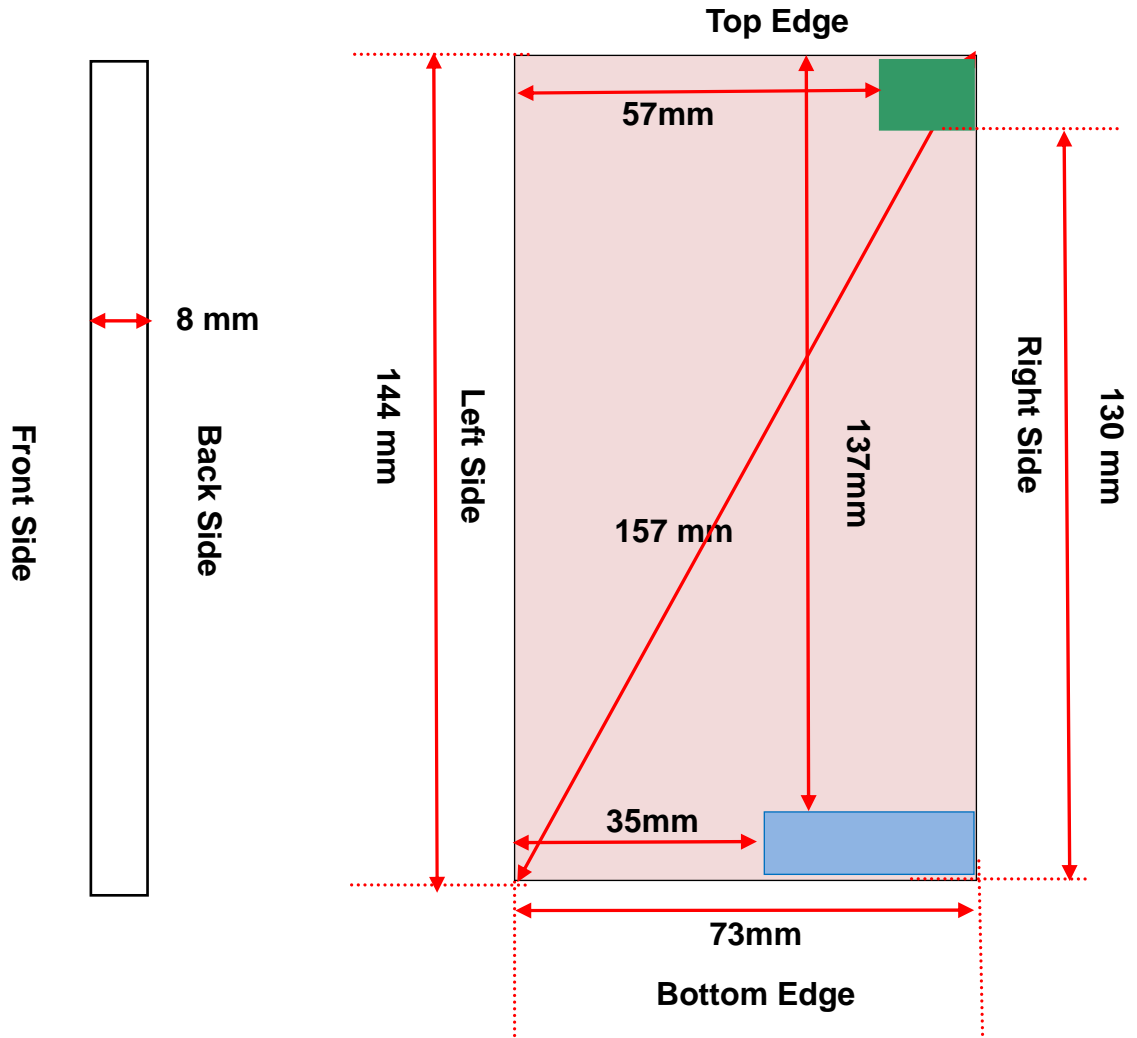

WLAN/BT Antenna

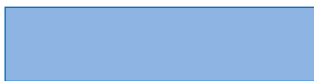

WWAN Antenna



EUT Back View

9.1 SAR Test Exclusion Consider Table

According with FCC KDB 447498 D01, Appendix A, <SAR Test Exclusion Thresholds for 100 MHz - 6 GHz and ≤ 50 mm> Table, this Device SAR test configurations consider as following :

Band	Mode	Max. Peak Power		Test Position Configurations					
		dBm	mW	Head	Front/ Back	Left Edge	Right Edge	Top Edge	Bottom Edge
GSM 850	Distance to User			<5mm	<5mm	35mm	<5mm	137mm	<5mm
	Voice	33.00	1995.26	Yes	Yes	No	Yes	No	Yes
	Data	29.50	891.25	Yes	Yes	No	Yes	No	Yes
GSM 1900	Distance to User			<5mm	<5mm	35mm	<5mm	137mm	<5mm
	Voice	30.00	1000.00	Yes	Yes	No	Yes	No	Yes
	Data	26.50	446.68	Yes	Yes	No	Yes	No	Yes
WCDMA Band 2	Distance to User			<5mm	<5mm	35mm	<5mm	137mm	<5mm
	RMC	22.50	177.83	Yes	Yes	No	Yes	No	Yes
WCDMA Band 4	Distance to User			<5mm	<5mm	35mm	<5mm	137mm	<5mm
	RMC	22.50	177.83	Yes	Yes	No	Yes	No	Yes
WCDMA Band 5	Distance to User			<5mm	<5mm	35mm	<5mm	137mm	<5mm
	RMC	22.50	177.83	Yes	Yes	No	Yes	No	Yes
LTE Band 2	Distance to User			<5mm	<5mm	35mm	<5mm	137mm	<5mm
	QPSK	23.50	223.87	Yes	Yes	No	Yes	No	Yes
LTE Band 4	Distance to User			<5mm	<5mm	35mm	<5mm	137mm	<5mm
	QPSK	23.50	223.87	Yes	Yes	No	Yes	No	Yes
LTE Band 5	Distance to User			<5mm	<5mm	35mm	<5mm	137mm	<5mm
	QPSK	23.50	223.87	Yes	Yes	No	Yes	No	Yes
LTE Band 7	Distance to User			<5mm	<5mm	35mm	<5mm	137mm	<5mm
	QPSK	23.00	199.53	Yes	Yes	No	Yes	No	Yes
LTE Band 12	Distance to User			<5mm	<5mm	35mm	<5mm	137mm	<5mm
	QPSK	23.50	223.87	Yes	Yes	No	Yes	No	Yes
LTE Band 17	Distance to User			<5mm	<5mm	35mm	<5mm	137mm	<5mm
	QPSK	23.50	223.87	Yes	Yes	No	Yes	No	Yes
WLAN 2.4 G	Distance to User			<5mm	<5mm	57mm	<5mm	<5mm	130mm
	802.11b	15.50	35.48	Yes	Yes	No	Yes	Yes	No
	802.11g	18.50	70.79	No	No	No	No	No	No
	802.11n(HT20)	18.50	70.79	No	No	No	No	No	No
	802.11n(HT40)	18.50	70.79	No	No	No	No	No	No
Bluetooth	Distance to User			<5mm	<5mm	57mm	<5mm	<5mm	130mm
	Bluetooth BR/EDR	1.00	1.26	No	No	No	No	No	No
	Bluetooth BLE	1.00	1.26	No	No	No	No	No	No

Note:

- Maximum power is the source-based time-average power and represents the maximum RF output power among production units.
- Per KDB 447498 D01, for larger devices, the test separation distance of adjacent edge configuration is determined by

the closest separation between the antenna and the user.

3. Per KDB 447498 D01, standalone SAR test exclusion threshold is applied; If the distance of the antenna to the user is < 5mm, 5mm is used to determine SAR exclusion threshold
4. Per KDB 447498 D01, the 1-g and 10-g SAR test exclusion thresholds for 100 MHz to 6 GHz at test separation distances ≤ 50 mm are determined by:
[(max. power of channel, including tune-up tolerance, mW)/(min. test separation distance, mm)] $\cdot \sqrt{f(\text{GHz})} \leq 3.0$ for 1-g SAR and ≤ 7.5 for 10-g extremity SAR
 - a. $f(\text{GHz})$ is the RF channel transmit frequency in GHz
 - b. Power and distance are rounded to the nearest mW and mm before calculation
 - c. The result is rounded to one decimal place for comparison
 - d. For < 50 mm distance, we just calculate mW of the exclusion threshold value (3.0) to do compare.This formula is $[3.0] / [\sqrt{f(\text{GHz})}] \cdot [(\text{min. test separation distance, mm})] = \text{exclusion threshold of mW}$.
5. Per KDB 447498 D01, at 100 MHz to 6 GHz and for test separation distances > 50 mm, the SAR test exclusion threshold is determined according to the following:
 - a. [Threshold at 50 mm in step 1) + (test separation distance - 50 mm) \cdot (f(MHz)/150)] mW, at 100 MHz to 1500 MHz
 - b. [Threshold at 50 mm in step 1) + (test separation distance - 50 mm) \cdot 10] mW at > 1500 MHz and ≤ 6 GHz
6. Per KDB 941225 D01, When the maximum output power and tune-up tolerance specified for production units in a secondary mode is $\leq 1/4$ dB higher than the primary mode or when the highest reported SAR of the primary mode is scaled by the ratio of specified maximum output power and tune-up tolerance of secondary to primary mode and the adjusted SAR is ≤ 1.2 W/kg, SAR measurement is not required for the secondary mode.
7. Per KDB 941225 D05, SAR test reduction is applied using the following criteria:
 - a. Start with the largest channel bandwidth and measure SAR for QPSK with 1 RB, and 50% RB allocation, using the RB offset and required test channel combination with the highest maximum output power among RB offsets at the upper edge, middle and lower edge of each required test channel.
 - b. When the reported SAR is > 0.8 W/kg, testing for other Channels is performed at the highest output power level for 1RB, and 50% RB configuration for that channel.
 - c. Testing for 100% RB configuration is performed at the highest output power level for 100% RB configuration across the Low, Mid and High Channel when the highest reported SAR for 1 RB and 50% RB are > 0.8 W/kg. Testing for the remaining required channels is not needed because the reported SAR for 100% RB Allocation < 1.45 W/kg.
 - d. Testing for 16-QAM modulation is not required because the reported SAR for QPSK is < 1.45 W/Kg and its output power is not more than 0.5 dB higher than that of QPSK.
 - e. Testing for the other channel bandwidths is not required because the reported SAR for the highest channel bandwidth is < 1.45 W/Kg and its output power is not more than 0.5 dB higher than that of the highest channel bandwidth.
8. Per KDB 248227 D01 SAR is not required for the following 2.4 GHz OFDM conditions.
 - a. When the reported SAR of the highest measured maximum output power channel for the exposure configuration is ≤ 0.8 W/kg, no further SAR testing is required for 802.11b DSSS in that exposure configuration.
 - b. When the reported SAR is > 0.8 W/kg, SAR is required for that exposure configuration using the next highest measured output power channel. When any reported SAR is > 1.2 W/kg, SAR is required for the third channel.
9. Per KDB 248227 D01 SAR is not required for the following 2.4 GHz OFDM conditions.
 - a. When KDB Publication 447498 D01 SAR test exclusion applies to the OFDM configuration.
 - b. When the highest reported SAR for DSSS is adjusted by the ratio of OFDM to DSSS specified maximum output power and the adjusted SAR is ≤ 1.2 W/kg.
10. According to 2019 TCB workshop, FCC accept SAR testing with IEC tissue parameters for head and body, so this product only used IEC tissue parameters to perform SAR testing.

9.2 10g Extremity Exposure Consider

According with FCC KDB 648474 D04, for smart phones with a display diagonal dimension > 15.0 cm or an overall diagonal dimension > 16.0 cm that provide similar mobile web access and multimedia support found in mini-tablets or UMPC mini-tablets that support voice calls next to the ear, unless it is confirmed otherwise through KDB inquiries, the following phablet procedures should be applied to evaluate SAR compliance for each applicable wireless modes and frequency band. Devices marketed as phablets, regardless of form factors and operating characteristics must be tested as a phablet to determine SAR compliance;

The UMPC mini-tablet procedures must also be applied to test the SAR of all surfaces and edges with an antenna located at ≤ 25 mm from that surface or edge, in direct contact with a flat phantom, for 10-g extremity SAR according to the body-equivalent tissue dielectric parameters in KDB 865664 to address interactive hand use exposure conditions. The UMPC mini-tablet 1-g SAR at 5 mm is not required. When hotspot mode applies, 10-g extremity SAR is required only for the surfaces and edges with hotspot mode 1-g reported SAR > 1.2 W/kg.

Conclusion:

The EUT hotspot mode 1-g reported SAR is 0.964 W/Kg, which is less than 1.2W/Kg, 10-g extremity SAR is not required.

10 TEST RESULTS

10.1 GSM 850

Mode	Position	Dist. (mm)	Ch.	Freq. (MHz)	Power Drift (%)	Meas. SAR1 g (W/Kg)	Meas. Power (dBm)	Max. tune-up Power (dBm)	Scaling Factor	1 g Scaled SAR (W/Kg)	Meas. No.
Head											
GPRS (4slots)	Left Cheek	0	251	848.80	-0.58	0.704	29.05	29.50	1.109	0.780	1#
	Left Tilt	0	251	848.80	-4.30	0.283	29.05	29.50	1.109	0.314	/
	Right Cheek	0	251	848.80	0.78	0.669	29.05	29.50	1.109	0.742	/
	Right Tilt	0	251	848.80	0.12	0.244	29.05	29.50	1.109	0.270	/
Body-worn&Hotspot (10mm)											
Voice	Front Side	10	251	848.80	4.57	0.289	32.50	33.00	1.122	0.324	/
	Back Side	10	251	848.80	-0.27	0.478	32.50	33.00	1.122	0.536	/
GPRS (4slots)	Front Side	10	251	848.80	-0.26	0.558	29.05	29.50	1.109	0.619	/
	Back Side	10	251	848.80	-3.63	0.867	29.05	29.50	1.109	0.961	2#
		10	128	824.20	4.01	0.781	28.76	29.50	1.186	0.926	/
		10	190	836.60	-0.59	0.805	28.90	29.50	1.148	0.924	/
	Right Edge	10	251	848.80	0.56	0.568	29.05	29.50	1.109	0.630	/
	Bottom Edge	10	251	848.80	-0.35	0.155	29.05	29.50	1.109	0.172	/
Note: Refer to ANNEX C for the detailed test data for each test configuration.											

10.2 GSM 1900

Mode	Position	Dist. (mm)	Ch.	Freq. (MHz)	Power Drift (%)	Meas. SAR1 g (W/Kg)	Meas. Power (dBm)	Max. tune-up Power (dBm)	Scaling Factor	1 g Scaled SAR (W/Kg)	Meas. No.
Head											
GPRS (4slots)	Left Cheek	0	512	1850.20	-3.94	0.185	26.12	26.50	1.091	0.202	3#
	Left Tilt	0	512	1850.20	-0.42	0.078	26.12	26.50	1.091	0.085	/
	Right Cheek	0	512	1850.20	-3.58	0.089	26.12	26.50	1.091	0.097	/
	Right Tilt	0	512	1850.20	-3.10	0.049	26.12	26.50	1.091	0.053	/
Body-worn&Hotspot (10mm)											
Voice	Front Side	10	512	1850.20	1.45	0.224	29.23	30.00	1.194	0.267	/
	Back Side	10	512	1850.20	4.45	0.374	29.23	30.00	1.194	0.447	/
GPRS (4slots)	Front Side	10	512	1850.20	0.07	0.352	26.12	26.50	1.091	0.384	/
	Back Side	10	512	1850.20	0.10	0.506	26.12	26.50	1.091	0.552	4#
	Right Edge	10	512	1850.20	-3.77	0.132	26.12	26.50	1.091	0.144	/
	Bottom Edge	10	512	1850.20	0.76	0.150	26.12	26.50	1.091	0.164	/
Note: Refer to ANNEX C for the detailed test data for each test configuration.											

10.3 WCDMA Band 2

Mode	Position	Dist. (mm)	Ch.	Freq. (MHz)	Power Drift (%)	Meas. SAR1 g (W/Kg)	Meas. Power (dBm)	Max. tune-up Power (dBm)	Scaling Factor	1 g Scaled SAR (W/Kg)	Meas. No.
Head											
RMC	Left Cheek	0	9400	1880.00	-2.99	0.202	21.94	22.50	1.138	0.230	5#
	Left Tilt	0	9400	1880.00	-0.86	0.108	21.94	22.50	1.138	0.123	/
	Right Cheek	0	9400	1880.00	-3.54	0.039	21.94	22.50	1.138	0.044	/
	Right Tilt	0	9400	1880.00	0.12	0.046	21.94	22.50	1.138	0.052	/
Body-worn&Hotspot (10mm)											
RMC	Front Side	10	9400	1880.00	-0.45	0.390	21.94	22.50	1.138	0.444	/
	Back Side	10	9400	1880.00	-0.56	0.550	21.94	22.50	1.138	0.626	6#
	Right Edge	10	9400	1880.00	-3.92	0.207	21.94	22.50	1.138	0.235	/
	Bottom Edge	10	9400	1880.00	-0.56	0.174	21.94	22.50	1.138	0.198	/
Note: Refer to ANNEX C for the detailed test data for each test configuration.											

10.4 WCDMA Band 4

Mode	Position	Dist. (mm)	Ch.	Freq. (MHz)	Power Drift (%)	Meas. SAR1 g (W/Kg)	Meas. Power (dBm)	Max. tune-up Power (dBm)	Scaling Factor	1 g Scaled SAR (W/Kg)	Meas. No.
Head											
RMC	Left Cheek	0	1513	1752.60	-2.61	0.401	22.19	22.50	1.074	0.431	7#
	Left Tilt	0	1513	1752.60	-1.46	0.152	22.19	22.50	1.074	0.163	/
	Right Cheek	0	1513	1752.60	-4.04	0.214	22.19	22.50	1.074	0.230	/
	Right Tilt	0	1513	1752.60	-0.65	0.108	22.19	22.50	1.074	0.116	/
Body-worn&Hotspot (10mm)											
RMC	Front Side	10	1513	1752.60	-2.76	0.534	22.19	22.50	1.074	0.574	/
	Back Side	10	1513	1752.60	0.15	0.855	22.19	22.50	1.074	0.918	/
		10	1312	1712.40	-1.57	0.607	22.14	22.50	1.086	0.659	/
		10	1412	1732.40	-1.12	0.891	22.16	22.50	1.081	0.964	8#
	Right Edge	10	1513	1752.60	-2.41	0.259	22.19	22.50	1.074	0.278	/
	Bottom Edge	10	1513	1752.60	-0.22	0.441	22.19	22.50	1.074	0.474	/
Note: Refer to ANNEX C for the detailed test data for each test configuration.											

10.5WCDMA Band 5

Mode	Position	Dist. (mm)	Ch.	Freq. (MHz)	Power Drift (%)	Meas. SAR1 g (W/Kg)	Meas. Power (dBm)	Max. tune-up Power (dBm)	Scaling Factor	1 g Scaled SAR (W/Kg)	Meas. No.
Head											
RMC	Left Cheek	0	4132	826.40	-0.71	0.356	22.14	22.50	1.086	0.387	9#
	Left Tilt	0	4132	826.40	-3.34	0.153	22.14	22.50	1.086	0.166	/
	Right Cheek	0	4132	826.40	-1.84	0.248	22.14	22.50	1.086	0.269	/
	Right Tilt	0	4132	826.40	-0.73	0.144	22.14	22.50	1.086	0.156	/
Body-worn&Hotspot (10mm)											
RMC	Front Side	10	4132	826.40	-0.75	0.249	22.14	22.50	1.086	0.271	/
	Back Side	10	4132	826.40	-0.31	0.464	22.14	22.50	1.086	0.504	10#
	Right Edge	10	4132	826.40	-2.57	0.148	22.14	22.50	1.086	0.161	/
	Bottom Edge	10	4132	826.40	1.12	0.084	22.14	22.50	1.086	0.091	/
Note: Refer to ANNEX C for the detailed test data for each test configuration.											

10.6LTE Band 2 (20MHz Bandwidth)

Mode	Position	Dist. (mm)	Ch.	Freq. (MHz)	RB Numb.	RB Start	Power Drift (%)	Meas. SAR1 g (W/Kg)	Meas. Power (dBm)	Max. tune-up Power (dBm)	Scaling Factor	1 g Scaled SAR (W/Kg)	Meas. No.
Head													
QPSK	Left Cheek	0	18900	1880	1	Mid	-1.31	0.234	22.99	23.50	1.125	0.263	11#
		0	18700	1860	50	Mid	-0.92	0.150	21.80	22.00	1.047	0.157	/
	Left Tilt	0	18900	1880	1	Mid	0.19	0.110	22.99	23.50	1.125	0.124	/
		0	18700	1860	50	Mid	-1.10	0.081	21.80	22.00	1.047	0.085	/
	Right Cheek	0	18900	1880	1	Mid	-0.35	0.129	22.99	23.50	1.125	0.145	/
		0	18700	1860	50	Mid	-1.25	0.104	21.80	22.00	1.047	0.109	/
	Right Tilt	0	18900	1880	1	Mid	-3.92	0.060	22.99	23.50	1.125	0.067	/
		0	18700	1860	50	Mid	1.61	0.052	21.80	22.00	1.047	0.054	/
Body-worn&Hotspot (10mm)													
QPSK	Front Side	10	18900	1880	1	Mid	-2.48	0.352	22.99	23.50	1.125	0.396	/
		10	18700	1860	50	Mid	-2.90	0.280	21.80	22.00	1.047	0.293	/
	Back Side	10	18900	1880	1	Mid	-1.21	0.481	22.99	23.50	1.125	0.541	12#
		10	18700	1860	50	Mid	-1.48	0.391	21.80	22.00	1.047	0.409	/
	Right Edge	10	18900	1880	1	Mid	-1.40	0.205	22.99	23.50	1.125	0.231	/
		10	18700	1860	50	Mid	-2.78	0.155	21.80	22.00	1.047	0.162	/
	Bottom Edge	10	18900	1880	1	Mid	0.30	0.213	22.99	23.50	1.125	0.240	/
		10	18700	1860	50	Mid	-0.01	0.167	21.80	22.00	1.047	0.175	/
Note: Refer to ANNEX C for the detailed test data for each test configuration.													

10.7 LTE Band 4 (20MHz Bandwidth)

Mode	Position	Dist. (mm)	Ch.	Freq. (MHz)	RB Numb.	RB Start	Power Drift (%)	Meas. SAR1 g (W/Kg)	Meas. Power (dBm)	Max. tune-up Power (dBm)	Scaling Factor	1 g Scaled SAR (W/Kg)	Meas. No.
Head													
QPSK	Left Cheek	0	20175	1732.5	1	Mid	-2.03	0.537	22.97	23.50	1.130	0.607	13#
		0	20050	1720	50	Mid	-3.31	0.409	21.85	22.50	1.161	0.475	/
	Left Tilt	0	20175	1732.5	1	Mid	-2.36	0.221	22.97	23.50	1.130	0.250	/
		0	20050	1720	50	Mid	-3.89	0.161	21.85	22.50	1.161	0.187	/
	Right Cheek	0	20175	1732.5	1	Mid	-1.18	0.280	22.97	23.50	1.130	0.316	/
		0	20050	1720	50	Mid	-3.71	0.208	21.85	22.50	1.161	0.242	/
	Right Tilt	0	20175	1732.5	1	Mid	-3.15	0.157	22.97	23.50	1.130	0.177	/
		0	20050	1720	50	Mid	-2.85	0.119	21.85	22.50	1.161	0.138	/
Body-worn&Hotspot (10mm)													
QPSK	Front Side	10	20175	1732.5	1	Mid	-1.20	0.393	22.97	23.50	1.130	0.444	/
		10	20050	1720	50	Mid	-1.05	0.302	21.85	22.50	1.161	0.351	/
	Back Side	10	20175	1732.5	1	Mid	-0.02	0.701	22.97	23.50	1.130	0.792	14#
		10	20050	1720	50	Mid	-1.57	0.560	21.85	22.50	1.161	0.650	/
	Right Edge	10	20175	1732.5	1	Mid	-1.99	0.203	22.97	23.50	1.130	0.229	/
		10	20050	1720	50	Mid	-2.25	0.155	21.85	22.50	1.161	0.180	/
	Bottom Edge	10	20175	1732.5	1	Mid	-0.75	0.637	22.97	23.50	1.130	0.720	/
		10	20050	1720	50	Mid	-3.52	0.413	21.85	22.50	1.161	0.480	/
Note: Refer to ANNEX C for the detailed test data for each test configuration.													

10.8LTE Band 5 (10MHz Bandwidth)

Mode	Position	Dist. (mm)	Ch.	Freq. (MHz)	RB Numb.	RB Start	Power Drift (%)	Meas. SAR1 g (W/Kg)	Meas. Power (dBm)	Max. tune-up Power (dBm)	Scaling Factor	1 g Scaled SAR (W/Kg)	Meas. No.
Head													
QPSK	Left Cheek	0	20525	836.5	1	Mid	-1.20	0.457	23.19	23.50	1.074	0.491	15#
		0	20525	836.5	25	High	2.03	0.274	22.21	22.50	1.069	0.293	/
	Left Tilt	0	20525	836.5	1	Mid	-2.70	0.174	23.19	23.50	1.074	0.187	/
		0	20525	836.5	25	High	0.15	0.128	22.21	22.50	1.069	0.137	/
	Right Cheek	0	20525	836.5	1	Mid	0.18	0.318	23.19	23.50	1.074	0.342	/
		0	20525	836.5	25	High	0.44	0.256	22.21	22.50	1.069	0.274	/
	Right Tilt	0	20525	836.5	1	Mid	-3.44	0.167	23.19	23.50	1.074	0.179	/
		0	20525	836.5	25	High	-2.35	0.139	22.21	22.50	1.069	0.149	/
Body-worn&Hotspot (10mm)													
QPSK	Front Side	10	20525	836.5	1	Mid	-0.02	0.327	23.19	23.50	1.074	0.351	/
		10	20525	836.5	25	High	-1.31	0.405	22.21	22.50	1.069	0.433	/
	Back Side	10	20525	836.5	1	Mid	-0.72	0.597	23.19	23.50	1.074	0.641	16#
		10	20525	836.5	25	High	-2.20	0.486	22.21	22.50	1.069	0.520	/
	Right Edge	10	20525	836.5	1	Mid	-0.70	0.365	23.19	23.50	1.074	0.392	/
		10	20525	836.5	25	High	-0.43	0.290	22.21	22.50	1.069	0.310	/
	Bottom Edge	10	20525	836.5	1	Mid	-1.11	0.177	23.19	23.50	1.074	0.190	/
		10	20525	836.5	25	High	-1.09	0.142	22.21	22.50	1.069	0.152	/
Note: Refer to ANNEX C for the detailed test data for each test configuration.													

10.9LTE Band 7 (20MHz Bandwidth)

Mode	Position	Dist. (mm)	Ch.	Freq. (MHz)	RB Numb.	RB Start	Power Drift (%)	Meas. SAR1 g (W/Kg)	Meas. Power (dBm)	Max. tune-up Power (dBm)	Scaling Factor	1 g Scaled SAR (W/Kg)	Meas. No.
Head													
QPSK	Left Cheek	0	20850	2510	1	High	-1.25	0.106	22.32	23.00	1.169	0.124	17#
		0	20850	2510	50	High	0.05	0.096	21.93	22.50	1.140	0.109	/
	Left Tilt	0	20850	2510	1	High	0.45	0.083	22.32	23.00	1.169	0.097	/
		0	20850	2510	50	High	4.22	0.076	21.93	22.50	1.140	0.087	/
	Right Cheek	0	20850	2510	1	High	-3.67	0.040	22.32	23.00	1.169	0.047	/
		0	20850	2510	50	High	-1.45	0.038	21.93	22.50	1.140	0.043	/
	Right Tilt	0	20850	2510	1	High	-3.08	0.028	22.32	23.00	1.169	0.033	/
		0	20850	2510	50	High	-0.48	0.024	21.93	22.50	1.140	0.027	/
Body-worn&Hotspot (10mm)													
QPSK	Front Side	10	20850	2510	1	High	0.15	0.122	22.32	23.00	1.169	0.143	/
		10	20850	2510	50	High	2.04	0.104	21.93	22.50	1.140	0.119	/
	Back Side	10	20850	2510	1	High	-1.09	0.183	22.32	23.00	1.169	0.214	18#
		10	20850	2510	50	High	-1.30	0.143	21.93	22.50	1.140	0.163	/
	Right Edge	10	20850	2510	1	High	0.56	0.088	22.32	23.00	1.169	0.103	/
		10	20850	2510	50	High	0.58	0.058	21.93	22.50	1.140	0.066	/
	Bottom Edge	10	20850	2510	1	High	-0.71	0.055	22.32	23.00	1.169	0.064	/
		10	20850	2510	50	High	-2.19	0.047	21.93	22.50	1.140	0.054	/
Note: Refer to ANNEX C for the detailed test data for each test configuration.													

10.10 LTE Band 12 (10MHz Bandwidth)

Mode	Position	Dist. (mm)	Ch.	Freq. (MHz)	RB Numb.	RB Start	Power Drift (%)	Meas. SAR1 g (W/Kg)	Meas. Power (dBm)	Max. tune-up Power (dBm)	Scaling Factor	1 g Scaled SAR (W/Kg)	Meas. No.
Head													
QPSK	Left Cheek	0	23095	707.5	1	Mid	-0.04	0.176	23.07	23.50	1.104	0.194	/
		0	23095	707.5	25	High	-0.59	0.168	22.19	22.50	1.074	0.180	/
	Left Tilt	0	23095	707.5	1	Mid	-2.55	0.097	23.07	23.50	1.104	0.107	/
		0	23095	707.5	25	High	-0.65	0.087	22.19	22.50	1.074	0.093	/
	Right Cheek	0	23095	707.5	1	Mid	-0.66	0.236	23.07	23.50	1.104	0.261	19#
		0	23095	707.5	25	High	-0.28	0.186	22.19	22.50	1.074	0.200	/
	Right Tilt	0	23095	707.5	1	Mid	-0.71	0.126	23.07	23.50	1.104	0.139	/
		0	23095	707.5	25	High	-0.06	0.082	22.19	22.50	1.074	0.088	/
Body-worn&Hotspot (10mm)													
QPSK	Front Side	10	23095	707.5	1	Mid	-0.40	0.266	23.07	23.50	1.104	0.294	/
		10	23095	707.5	25	High	0.23	0.201	22.19	22.50	1.074	0.216	/
	Back Side	10	23095	707.5	1	Mid	-0.06	0.442	23.07	23.50	1.104	0.488	20#
		10	23095	707.5	25	High	0.23	0.454	22.19	22.50	1.074	0.488	/
	Right Edge	10	23095	707.5	1	Mid	-0.76	0.272	23.07	23.50	1.104	0.300	/
		10	23095	707.5	25	High	-0.90	0.196	22.19	22.50	1.074	0.211	/
	Bottom Edge	10	23095	707.5	1	Mid	-1.49	0.054	23.07	23.50	1.104	0.060	/
		10	23095	707.5	25	High	-0.85	0.047	22.19	22.50	1.074	0.050	/
Note: Refer to ANNEX C for the detailed test data for each test configuration.													

10.11 LTE Band 17 (10MHz Bandwidth)

Mode	Position	Dist. (mm)	Ch.	Freq. (MHz)	RB Numb.	RB Start	Power Drift (%)	Meas. SAR1 g (W/Kg)	Meas. Power (dBm)	Max. tune-up Power (dBm)	Scaling Factor	1 g Scaled SAR (W/Kg)	Meas. No.
Head													
QPSK	Left Cheek	0	23790	710	1	Mid	3.17	0.197	23.10	23.50	1.096	0.216	/
		0	23780	709	25	High	-3.15	0.160	22.05	22.50	1.109	0.177	/
	Left Tilt	0	23790	710	1	Mid	-0.04	0.108	23.10	23.50	1.096	0.118	/
		0	23780	709	25	High	-0.47	0.088	22.05	22.50	1.109	0.098	/
	Right Cheek	0	23790	710	1	Mid	-1.46	0.270	23.10	23.50	1.096	0.296	21#
		0	23780	709	25	High	-0.09	0.225	22.05	22.50	1.109	0.250	/
	Right Tilt	0	23790	710	1	Mid	-0.57	0.150	23.10	23.50	1.096	0.164	/
		0	23780	709	25	High	-0.05	0.081	22.05	22.50	1.109	0.090	/
Body-worn&Hotspot (10mm)													
QPSK	Front Side	10	23790	710	1	Mid	-0.78	0.280	23.10	23.50	1.096	0.307	/
		10	23780	709	25	High	-0.89	0.203	22.05	22.50	1.109	0.225	/
	Back Side	10	23790	710	1	Mid	-0.16	0.463	23.10	23.50	1.096	0.508	22#
		10	23780	709	25	High	0.19	0.411	22.05	22.50	1.109	0.456	/
	Right Edge	10	23790	710	1	Mid	-0.74	0.287	23.10	23.50	1.096	0.315	/
		10	23780	709	25	High	-0.71	0.228	22.05	22.50	1.109	0.253	/
	Bottom Edge	10	23790	710	1	Mid	-0.91	0.060	23.10	23.50	1.096	0.066	/
		10	23780	709	25	High	-0.91	0.051	22.05	22.50	1.109	0.057	/
Note: Refer to ANNEX C for the detailed test data for each test configuration.													

10.12 WIFI 2.4GHz

Mode	Position	Dist. (mm)	Ch.	Freq. (MHz)	Power Drift (%)	1 g Meas. SAR (W/Kg)	Meas. Power (dBm)	Max. tune-up Power (dBm)	Scaling Factor	Duty Cycle (%)	Duty Cycle Factor	1 g Scaled SAR (W/Kg)	Meas. No.
Head													
802.11 b	Left Cheek	0	6	2437	-1.11	0.135	15.03	15.50	1.114	99.52	1.005	0.151	/
	Left Tilt	0	6	2437	0.15	0.110	15.03	15.50	1.114	99.52	1.005	0.123	/
	Right Cheek	0	6	2437	-1.64	0.460	15.03	15.50	1.114	99.52	1.005	0.515	23#
	Right Tilt	0	6	2437	1.28	0.234	15.03	15.50	1.114	99.52	1.005	0.262	/
Body-worn&Hotspot (10mm)													
802.11 b	Front Side	10	6	2437	-0.91	0.088	15.03	15.50	1.114	99.52	1.005	0.099	/
	Back Side	10	6	2437	-0.17	0.174	15.03	15.50	1.114	99.52	1.005	0.195	24#
	Right Edge	10	6	2437	0.15	0.071	15.03	15.50	1.114	99.52	1.005	0.079	/
	Top Edge	10	6	2437	-1.05	0.023	15.03	15.50	1.114	99.52	1.005	0.026	/
Note: Refer to ANNEX C for the detailed test data for each test configuration.													

11 SAR Measurement Variability

According to KDB 865664 D01, SAR measurement variability was assessed for each frequency band, which is determined by the SAR probe calibration point and tissue-equivalent medium used for the device measurements. When both head and body tissue-equivalent media are required for SAR measurements in a frequency band, the variability measurement procedures should be applied to the tissue medium with the highest measured SAR, using the highest measured SAR configuration for that tissue-equivalent medium. Alternatively, if the highest measured SAR for both head and body tissue-equivalent media are ≤ 1.45 W/kg and the ratio of these highest SAR values, i.e., largest divided by smallest value, is ≤ 1.10 , the highest SAR configuration for either head or body tissue-equivalent medium may be used to perform the repeated measurement. These additional measurements are repeated after the completion of all measurements requiring the same head or body tissue-equivalent medium in a frequency band. The test device should be returned to ambient conditions (normal room temperature) with the battery fully charged before it is re-mounted on the device holder for the repeated measurement(s) to minimize any unexpected variations in the repeated results.

SAR repeated measurement procedure:

1. When the highest measured SAR is < 0.80 W/kg, repeated measurement is not required.
2. When the highest measured SAR is ≥ 0.80 W/kg, repeat that measurement once.
3. If the ratio of largest to smallest SAR for the original and first repeated measurements is > 1.20 , or when the original or repeated measurement is ≥ 1.45 W/kg, perform a second repeated measurement.
4. If the ratio of largest to smallest SAR for the original, first and second repeated measurements is > 1.20 , and the original, first or second repeated measurement is ≥ 1.5 W/kg, perform a third repeated measurement.

Frequency Band (MHz)	Wireless Band	RF Exposure Conditions	Test Position	Highest Measured SAR (W/kg)	Repeated SAR (Yes/No)	Highest Measured SAR (W/kg)	Largest to Smallest SAR Ratio
850	GSM850	Body	Back Side	0.867	Yes	0.815	1.06
1750	WCDMA Band4	Body	Back Side	0.891	Yes	0.881	1.01

Note: The ratio of largest to smallest SAR for the original and first repeated measurements is < 1.20 , the second repeated measurement is not required.

12 SIMULTANEOUS TRANSMISSION

Simultaneous transmission SAR test exclusion is determined for each operating configuration and exposure condition according to the reported standalone SAR of each applicable simultaneous transmitting antenna. When the sum of SAR 1g of all simultaneously transmitting antennas in an operating mode and exposure condition combination is within the SAR limit (SAR 1g 1.6 W/kg), the simultaneous transmission SAR is not required. When the sum of SAR 1g is greater than the SAR limit (SAR 1g 1.6 W/kg), SAR test exclusion is determined by the SAR to Peak Location Ratio (SPLSR).

12.1 Simultaneous Transmission Mode Consider

NO.	Mode	2.4G WLAN & Bluetooth		
		Head	Body-worn	Hotspot
1	GSM	+ Bluetooth	+ Bluetooth	+ Bluetooth
		+ 2.4G WLAN	+ 2.4G WLAN	+ 2.4G WLAN
2	WCDMA RMC	+ Bluetooth	+ Bluetooth	+ Bluetooth
		+ 2.4G WLAN	+ 2.4G WLAN	+ 2.4G WLAN
3	LTE	+ Bluetooth	+ Bluetooth	+ Bluetooth
		+ 2.4G WLAN	+ 2.4G WLAN	+ 2.4G WLAN

Note:

- 2G&3G&4G share the same antenna and can't transmit simultaneously.
- The Bluetooth and 2.4G WLAN share the same antenna, can't transmitting together.
- Both the 2.4G WLAN or Bluetooth can transmit simultaneously with each WWAN.

12.2 Estimated SAR Calculation

According to KDB 447498 D01 when standalone SAR test exclusion applies to an antenna that transmits simultaneously with other antennas, the standalone SAR was estimated according to following formula to result in substantially conservative SAR values of ≤ 0.4 W/kg to determine simultaneous transmission SAR test exclusion.

$$\text{Estimated SAR} = \frac{\text{Max. Tune Up Power (mw)}}{\text{Min Test Separation Distance}} * \frac{\sqrt{f_{\text{GHz}}}}{x} \quad (\text{where } x = 7.5 \text{ for 1-g SAR})$$

If the minimum test separation distance is < 5 mm, a distance of 5 mm is used for estimated SAR calculation. When the test separation distance is > 50 mm, the 0.4 W/kg is used for SAR-1g.

Band	Mode	Position	Antenna To user (mm)	SAR Testing	Max. Tune-up Power (dBm)	Max. Tune-up Power (mW)	Frequency (GHz)	Calculation Distance/Gap (mm)	Estimated SAR (W/kg)
Bluetooth	GFSK	Right Cheek	5	NO	1.00	1.26	2.480	5	0.053
		Left Cheek	5	NO	1.00	1.26	2.480	5	0.053
		Front side	10	NO	1.00	1.26	2.480	10	0.026
		Back Side	10	NO	1.00	1.26	2.480	10	0.026
		Right Edge	10	NO	1.00	1.26	2.480	10	0.026
		Top Edge	10	NO	1.00	1.26	2.480	10	0.026

12.3 Sum SAR of Simultaneous Transmission

12.3.1 Sum Head SAR of Simultaneous Transmission

Simultaneous Mode	Mode	Max. 1g SAR (W/kg)	1g Sum SAR (W/kg)	SPLSR (Yes/No)
GSM +Bluetooth	GSM	0.780	0.833	No
	Bluetooth	0.053		
GSM + 2.4G WLAN	GSM	0.780	1.295	No
	2.4G WLAN	0.515		
WCDMA RMC +Bluetooth	WCDMA RMC	0.431	0.484	No
	Bluetooth	0.053		
WCDMA RMC +2.4G WLAN	WCDMA RMC	0.431	0.946	No
	2.4G WLAN	0.515		
LTE QPSK + Bluetooth	LTE QPSK	0.607	0.660	No
	Bluetooth	0.053		
LTE QPSK + 2.4G WLAN	LTE QPSK	0.607	1.122	No
	2.4G WLAN	0.515		

12.3.2 Sum Body-worn SAR of Simultaneous Transmission

Simultaneous Mode	Mode	Max. 1g SAR (W/kg)	1g Sum SAR (W/kg)	SPLSR (Yes/No)
GSM +Bluetooth	GSM	0.961	0.987	No
	Bluetooth	0.026		
GSM + 2.4G WLAN	GSM	0.961	1.156	No
	2.4G WLAN	0.195		
WCDMA RMC +Bluetooth	WCDMA RMC	0.964	0.990	No
	Bluetooth	0.026		
WCDMA RMC +2.4G WLAN	WCDMA RMC	0.964	1.159	No
	2.4G WLAN	0.195		
LTE QPSK + Bluetooth	LTE QPSK	0.792	0.828	No
	Bluetooth	0.026		
LTE QPSK + 2.4G WLAN	LTE QPSK	0.792	0.987	No
	2.4G WLAN	0.195		

12.3.3 Sum Hotspot mode SAR of Simultaneous Transmission

Simultaneous Mode	Mode	Max. 1g SAR (W/kg)	1g Sum SAR (W/kg)	SPLSR (Yes/No)
GSM +Bluetooth	GSM	0.961	0.987	No
	Bluetooth	0.026		
GSM + 2.4G WLAN	GSM	0.961	1.156	No
	2.4G WLAN	0.195		
WCDMA RMC +Bluetooth	WCDMA RMC	0.964	0.990	No
	Bluetooth	0.026		
WCDMA RMC +2.4G WLAN	WCDMA RMC	0.964	1.159	No
	2.4G WLAN	0.195		
LTE QPSK + Bluetooth	LTE QPSK	0.792	0.828	No
	Bluetooth	0.026		
LTE QPSK + 2.4G WLAN	LTE QPSK	0.792	0.987	No
	2.4G WLAN	0.195		

13 TEST EQUIPMENTS LIST

Description	Manufacturer	Model	Serial No.	Cal. Date	Cal. Due
750MHz Dipole	SATIMO	SID 750	S/N 11/17 DIP 0G750-446	2017/03/22	2020/03/21
835MHz Dipole	SATIMO	SID 835	S/N 11/17 DIP 0G750-447	2017/03/22	2020/03/21
1800MHz Dipole	SATIMO	SID 1800	S/N 11/17 DIP 1G800-449	2017/03/22	2020/03/21
1900MHz Dipole	SATIMO	SID 1900	S/N 11/17 DIP 1G900-450	2017/03/22	2020/03/21
2450MHz Dipole	SATIMO	SID 2450	S/N 11/17 DIP 2G450-452	2017/03/22	2020/03/21
2600MHz Dipole	SATIMO	SID 2600	S/N 11/17 DIP 2G600-453	2017/03/22	2020/03/21
E-Field Probe	MVG	SSE2	S/N 34/15 EPGO 265	2019/03/19	2020/03/18
MultiMeter	Keithley	MultiMeter 2000	4024022	2019/06/17	2020/06/16
Signal Generator	R&S	SMBV100A	260592	2019/06/13	2020/06/12
Power Meter	Agilent	E4419B	GB40201833	2018/11/01	2019/10/31
Power Sensor	Agilent	E9300A	MY41498012	2018/11/01	2019/10/31
Power Sensor	Agilent	E9300A	MY41499891	2018/11/01	2019/10/31
Wireless Communication Test Set	Agilent	8960-E5515C	MY50260493	2019/06/13	2020/06/13
Wireless Communication Test Set	R&S	CMW 500	151885	2019/06/13	2020/06/13
Network Analyzer	R&S	ZVL-6	101380	2019/06/20	2020/06/19
Thermometer	Elitech	RC-4HC	N/A	2018/11/05	2019/11/04
Power Amplifier	SATIMO	6552B	22374	N/A	N/A
Dielectric Probe Kit	SATIMO	SCLMP	SN 25/13 OCPG56	N/A	N/A
Antenna	SATIMO	ANTA3	SN 17/13 ZNTA45	N/A	N/A
Phantom 1	SATIMO	SAM	SN 30/13 SAM103	N/A	N/A
Phantom 2	SATIMO	SAM	SN 30/13 SAM104	N/A	N/A
Attenuator	COM-MW	ZA-S1-31	1305003187	N/A	N/A
Directional coupler	AA-MCS	AAMCS-UDC	000272	N/A	N/A

Note: For dipole antennas, BALUN has adopted 3 years as calibration intervals, and on annual basis, every measurement dipole has been evaluated and is in compliance with the following criteria:

1. There is no physical damage on the dipole;
2. System validation with specific dipole is within 10% of calibrated value;
3. Return-loss in within 20% of calibrated measurement.
4. Impedance (real or imaginary parts) in within 5 Ohms of calibrated measurement.

ANNEX A SIMULATING LIQUID VERIFICATION RESULT

The dielectric parameters of the liquids were verified prior to the SAR evaluation using an SCLMP Dielectric Probe Kit.

Date	Liquid Type	Fre. (MHz)	Temp. (°C)	Meas. Conductivity(σ) (S/m)	Meas. Permittivity(ϵ)	Target Conductivity(σ) (S/m)	Target Permittivity(ϵ)	Conductivity Tolerance (%)	Permittivity Tolerance (%)
2019.09.11	Head	750	21.4	0.93	42.21	0.89	41.90	4.49	0.74
2019.09.12	Head	835	21.3	0.91	42.18	0.90	41.50	1.11	1.64
2019.09.10	Head	835	21.3	0.92	42.12	0.90	41.50	2.22	1.49
2019.09.16	Head	1800	21.1	1.44	38.65	1.40	40.00	2.86	-3.38
2019.09.17	Head	1900	21.3	1.37	39.42	1.40	40.00	-2.14	-1.45
2019.09.18	Head	1900	21.2	1.42	40.44	1.40	40.00	1.43	1.10
2019.09.09	Head	2450	21.1	1.82	39.00	1.80	39.20	1.11	-0.51
2019.09.08	Head	2600	21.2	1.99	38.32	1.96	39.01	1.53	-1.77

Note1: The tolerance limit of Conductivity and Permittivity is $\pm 5\%$.

Note2: According to April 2019 TCB workshop, FCC accept SAR testing with IEC tissue parameters, so this product used IEC tissue parameters to perform SAR testing.

ANNEX B SYSTEM CHECK RESULT

Comparing to the original SAR value provided by SATIMO, the validation data should be within its specification of 10% (for 1 g).

Date	Liquid Type	Freq. (MHz)	Power (mW)	Measured SAR (W/kg)	Normalized SAR (W/kg)	Dipole SAR (W/kg)	Tolerance (%)	Targeted SAR(W/kg)	Tolerance (%)
2019.09.11	Head	750	100	0.829	8.29	8.78	-5.58	8.49	-2.36
2019.09.12	Head	835	100	1.036	10.36	9.58	8.14	9.56	8.37
2019.09.10	Head	835	100	0.993	9.93	9.58	3.65	9.56	3.87
2019.09.16	Head	1800	100	3.840	38.40	38.76	-0.93	38.40	0.00
2019.09.17	Head	1900	100	4.210	42.10	39.49	6.61	39.70	6.05
2019.09.18	Head	1900	100	3.943	39.43	39.49	-0.15	39.70	-0.68
2019.09.09	Head	2450	100	5.330	53.30	54.31	-1.86	52.40	1.72
2019.09.08	Head	2600	100	5.411	54.11	56.32	-3.92	55.30	-2.15

Note1: The tolerance limit of System validation $\pm 10\%$.

Note2: According to April 2019 TCB workshop, FCC accept SAR testing with IEC tissue parameters, so this product used IEC tissue parameters to perform SAR testing.

System Performance Check Data(750 MHz)

Type: Phone measurement (Complete)
 E-Field Probe: SN 34/15 SSE2 EPGO265
 Area scan resolution: dx=8mm,dy=8mm
 Zoom scan resolution: dx=8mm, dy=8mm, dz=5mm
 Date of measurement: 2019.09.11
 Measurement duration: 14 minutes 27 seconds

Experimental conditions.

Phantom File	surf_sam_plan.txt
Phantom	Validation plane
Band	750MHz
Signal	CW
Frequency (MHz)	750MHz
Relative permittivity (real part)	42.210035
Conductivity (S/m)	0.927557
Power drift (%)	0.210000
Ambient Temperature:	22.7°C
Liquid Temperature:	21.4°C
ConvF:	1.89
Crest factor:	1:1

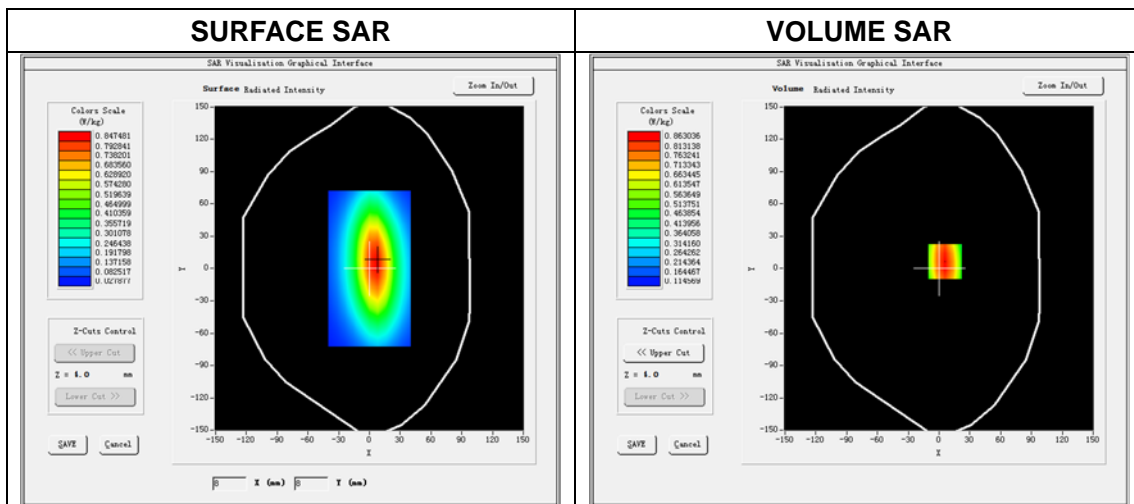

Maximum location: X=6.00, Y=6.00
 SAR Peak: 1.15 W/kg

SAR 10g (W/Kg)	0.559614
SAR 1g (W/Kg)	0.829343

Z Axis Scan



3D screen shot	Hot spot position

System Performance Check Data(835 MHz)

Type: Phone measurement (Complete)
 E-Field Probe: SN 34/15 SSE2 EPGO265
 Area scan resolution: dx=8mm,dy=8mm
 Zoom scan resolution: dx=8mm, dy=8mm, dz=5mm
 Date of measurement: 2019.09.12
 Measurement duration: 13 minutes 57 seconds

Experimental conditions.

Phantom File	surf_sam_plan.txt
Phantom	Validation plane
Band	835MHz
Signal	CW
Frequency (MHz)	835.000000
Relative permittivity (real part)	42.176125
Conductivity (S/m)	0.914183
Power drift (%)	-0.290000
Ambient Temperature:	22.5°C
Liquid Temperature:	21.3°C
ConvF:	1.93
Crest factor:	1:1

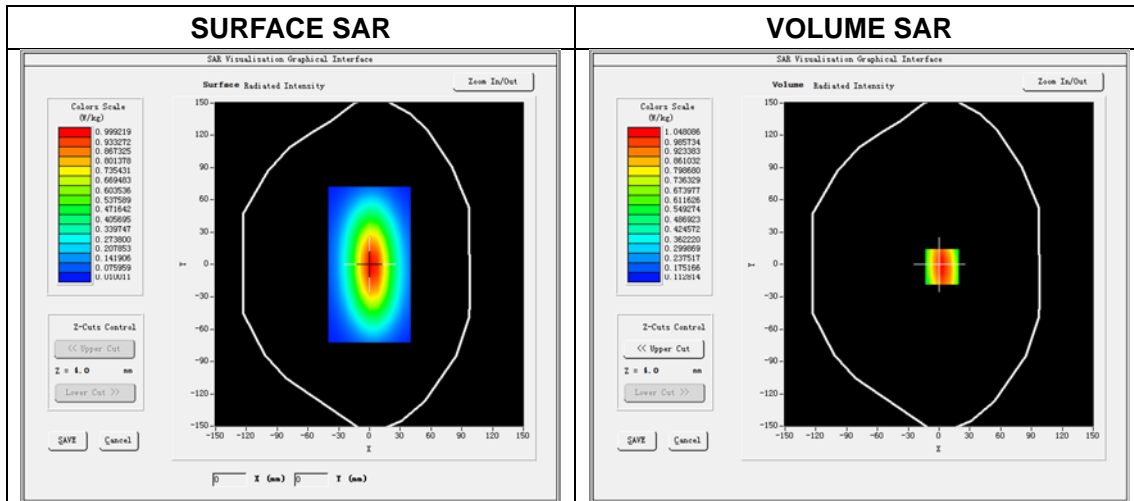

Maximum location: X=3.00, Y=-2.00
 SAR Peak: 1.36 W/kg

SAR 10 g (W/Kg)	0.641963
SAR 1g (W/Kg)	1.035769

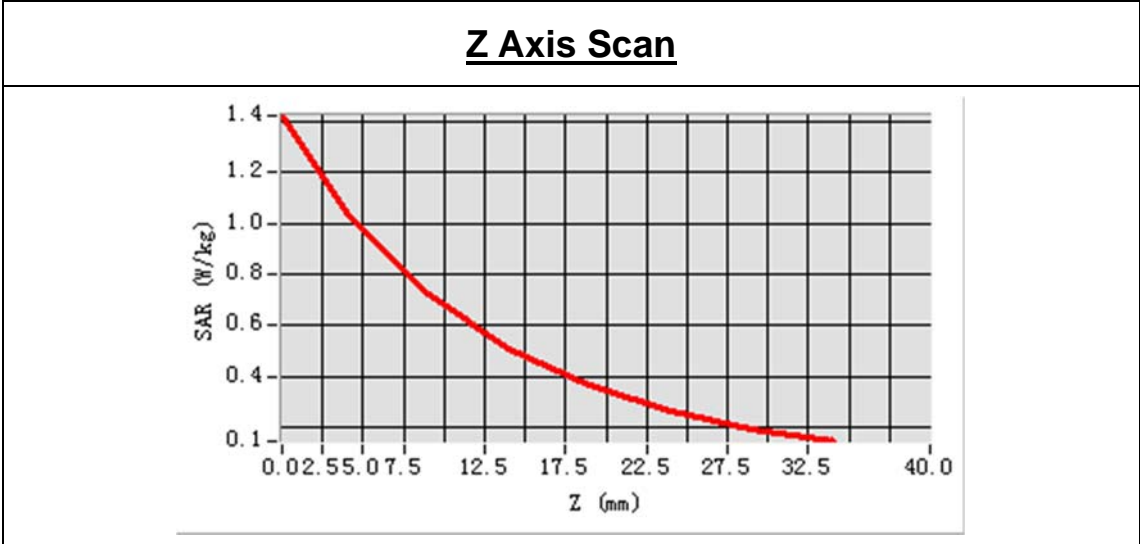

3D screen shot	Hot spot position

System Performance Check Data(835 MHz)

Type: Phone measurement (Complete)
 E-Field Probe: SN 34/15 SSE2 EPGO265
 Area scan resolution: dx=8mm,dy=8mm
 Zoom scan resolution: dx=8mm, dy=8mm, dz=5mm
 Date of measurement: 2019.09.10
 Measurement duration: 13 minutes 27 seconds

Experimental conditions.

Phantom File	surf_sam_plan.txt
Phantom	Validation plane
Band	835MHz
Signal	CW
Frequency (MHz)	835.000000
Relative permittivity (real part)	42.117869
Conductivity (S/m)	0.918952
Power drift (%)	0.130000
Ambient Temperature:	22.6°C
Liquid Temperature:	21.3°C
ConvF:	1.93
Crest factor:	1:1

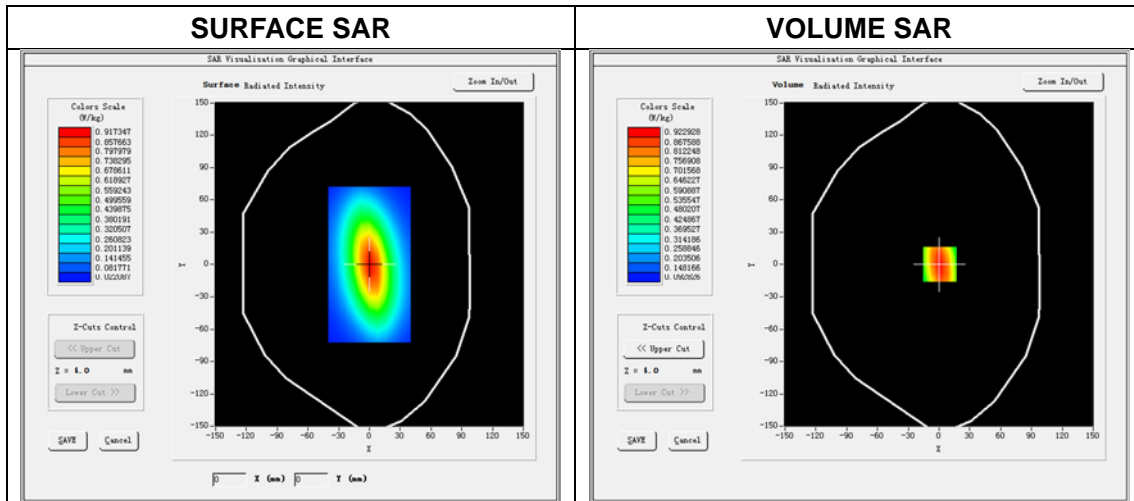

Maximum location: X=1.00, Y=0.00
 SAR Peak: 1.26 W/kg

SAR 10 g (W/Kg)	0.635918
SAR 1g (W/Kg)	0.992506

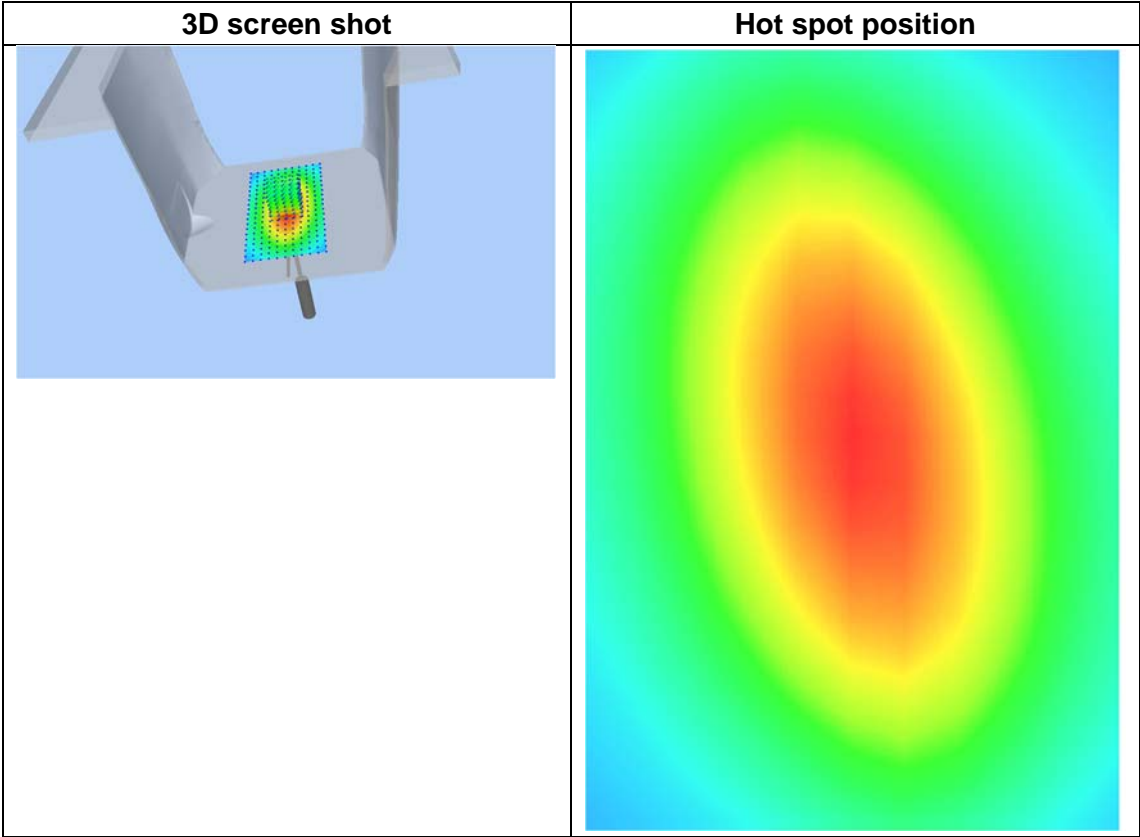
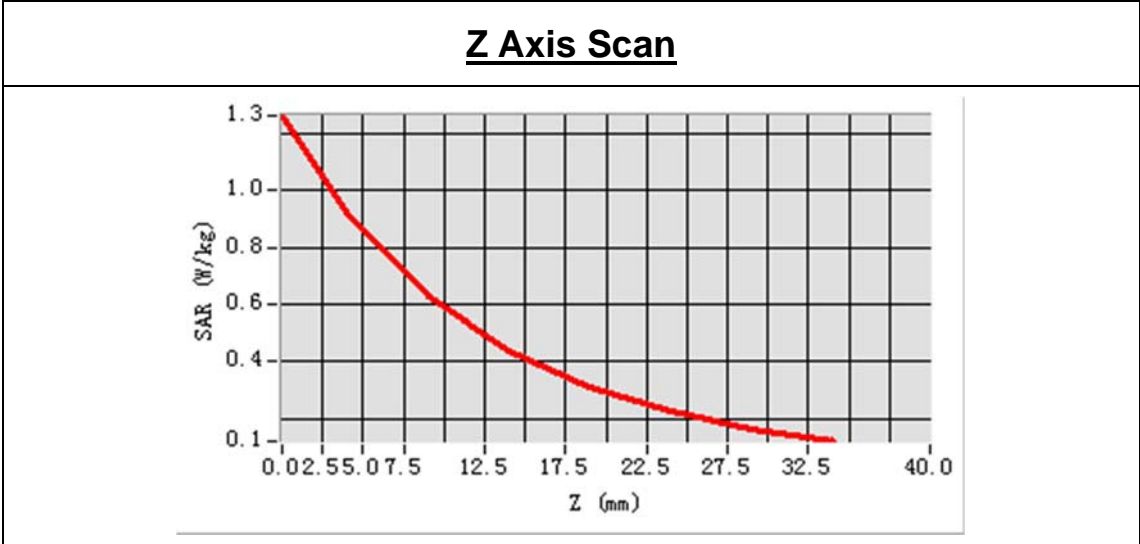

System Performance Check Data(1800MHz)

Type: Phone measurement (Complete)
 E-Field Probe: SN 34/15 SSE2 EPGO265
 Area scan resolution: dx=8mm,dy=8mm
 Zoom scan resolution: dx=8mm, dy=8mm, dz=5mm
 Date of measurement: 2019.09.16
 Measurement duration: 14 minutes 07 seconds

Experimental conditions.

Phantom File	surf_sam_plan.txt
Phantom	Validation plane
Band	1800MHz
Signal	CW
Frequency (MHz)	1800.000000
Relative permittivity (real part)	38.650500
Conductivity (S/m)	1.437616
Power drift (%)	0.770000
Ambient Temperature:	22.4°C
Liquid Temperature:	21.1°C
ConvF:	2.18
Crest factor:	1:1

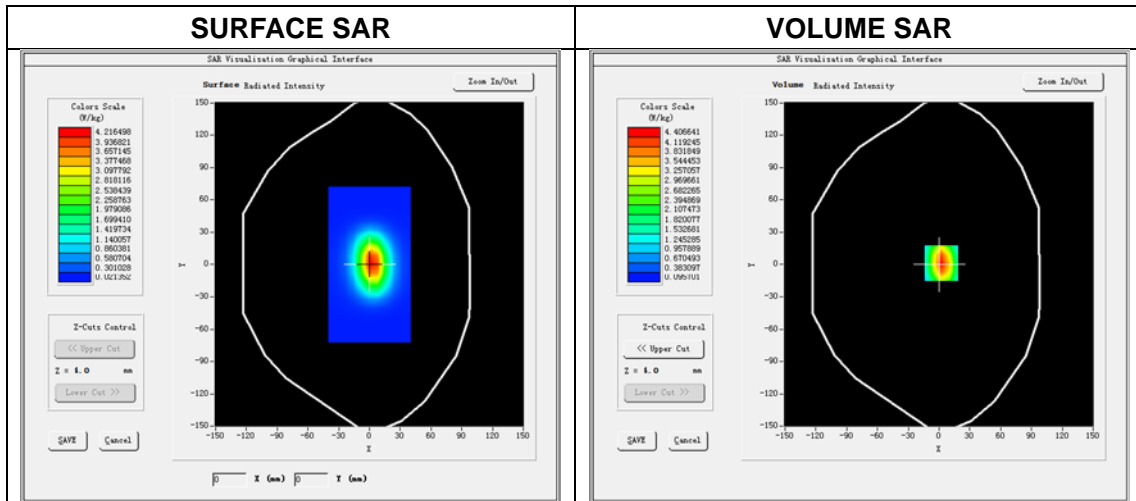

Maximum location: X=-1.00, Y=-1.00
 SAR Peak: 6.46W/kg

SAR 10g (W/Kg)	1.967525
SAR 1g (W/Kg)	3.840170

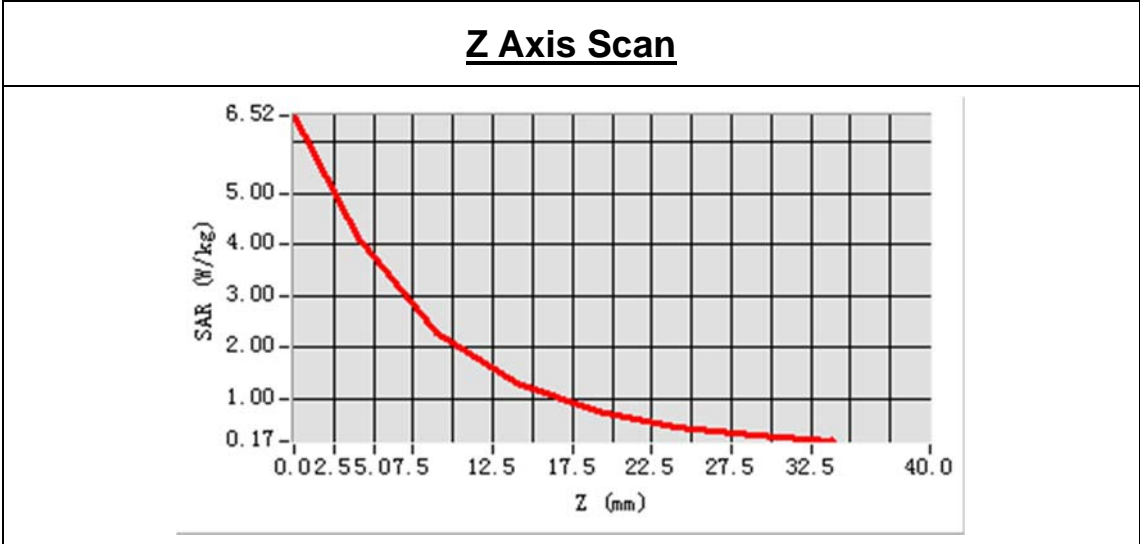

3D screen shot	Hot spot position

System Performance Check Data(1900MHz)

Type: Phone measurement (Complete)
 E-Field Probe: SN 34/15 SSE2 EPGO265
 Area scan resolution: dx=8mm,dy=8mm
 Zoom scan resolution: dx=8mm, dy=8mm, dz=5mm
 Date of measurement: 2019.09.17
 Measurement duration: 14 minutes 27 seconds

Experimental conditions.

Phantom File	surf_sam_plan.txt
Phantom	Validation plane
Band	1900MHz
Signal	CW
Frequency (MHz)	1900.000000
Relative permittivity (real part)	39.424448
Conductivity (S/m)	1.368153
Power drift (%)	0.470000
Ambient Temperature:	22.5°C
Liquid Temperature:	21.3°C
ConvF:	2.46
Crest factor:	1:1

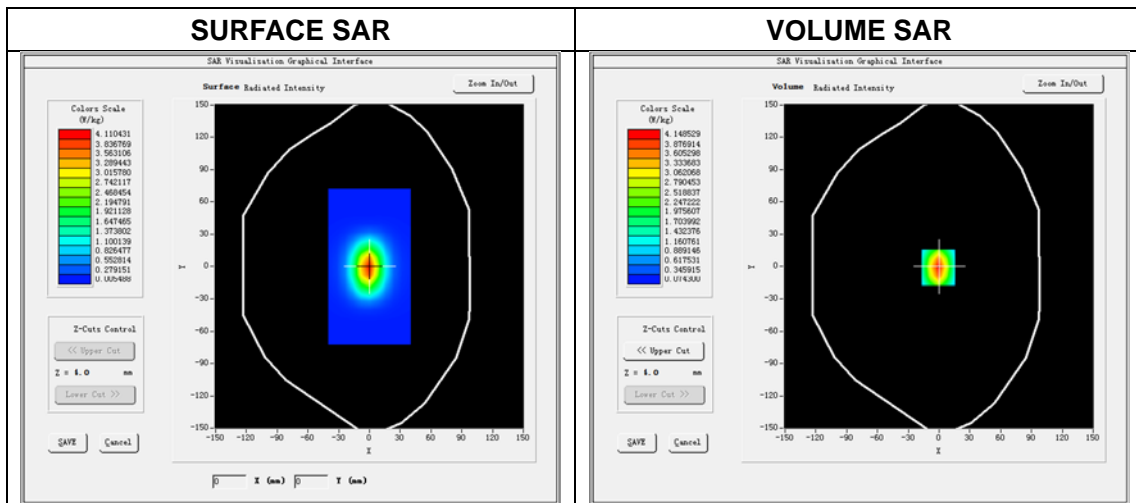

Maximum location: X=2.00, Y=1.00
 SAR Peak: 6.95 W/kg

SAR 10 g (W/Kg)	2.165522
SAR 1g (W/Kg)	4.210127

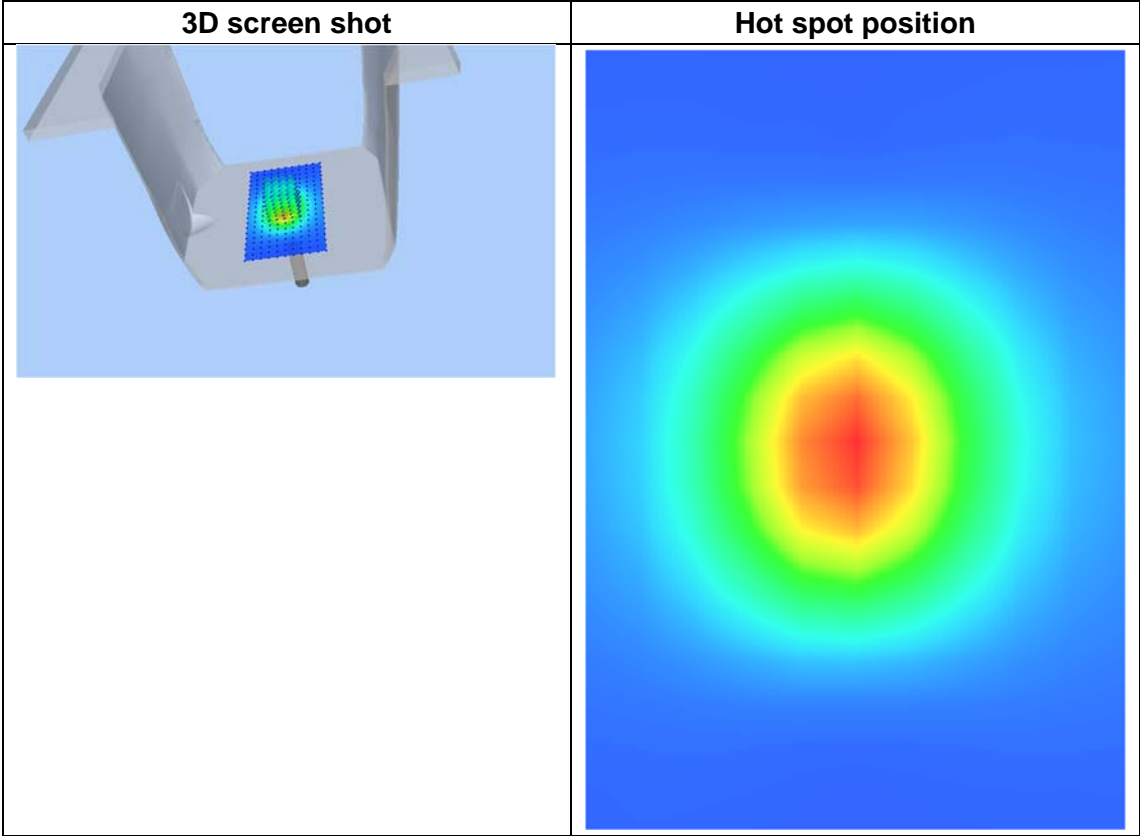
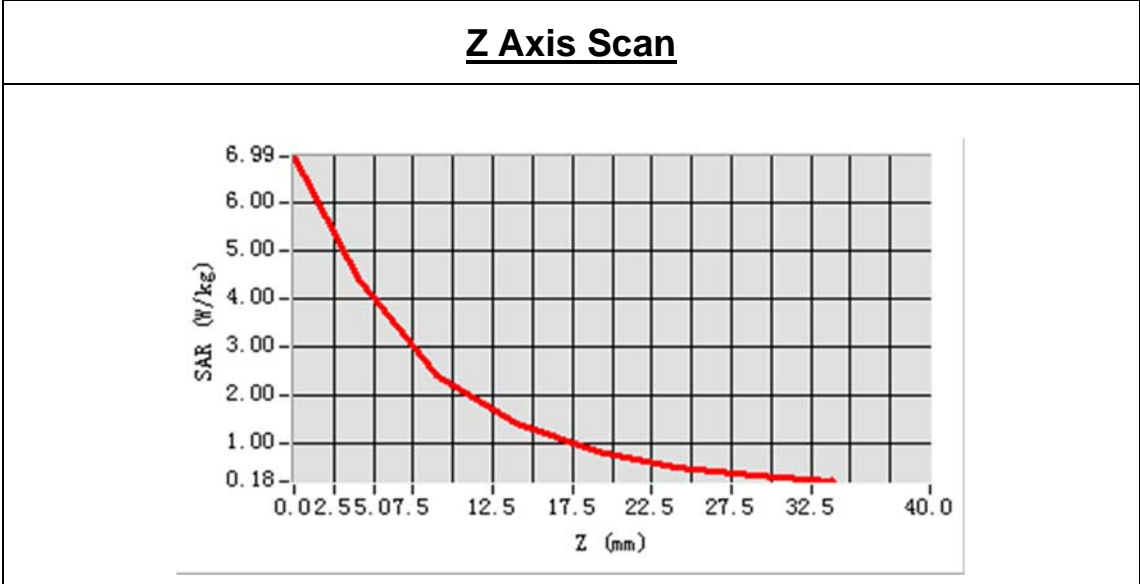

System Performance Check Data(1900MHz)

Type: Phone measurement (Complete)
 E-Field Probe: SN 34/15 SSE2 EPGO265
 Area scan resolution: dx=8mm,dy=8mm
 Zoom scan resolution: dx=8mm, dy=8mm, dz=5mm
 Date of measurement: 2019.09.18
 Measurement duration: 14 minutes 6 seconds

Experimental conditions.

Phantom File	surf_sam_plan.txt
Phantom	Validation plane
Band	1900MHz
Signal	CW
Frequency (MHz)	1900.000000
Relative permittivity (real part)	40.435326
Conductivity (S/m)	1.416835
Power drift (%)	-0.590000
Ambient Temperature:	22.4°C
Liquid Temperature:	21.2°C
ConvF:	2.46
Crest factor:	1:1

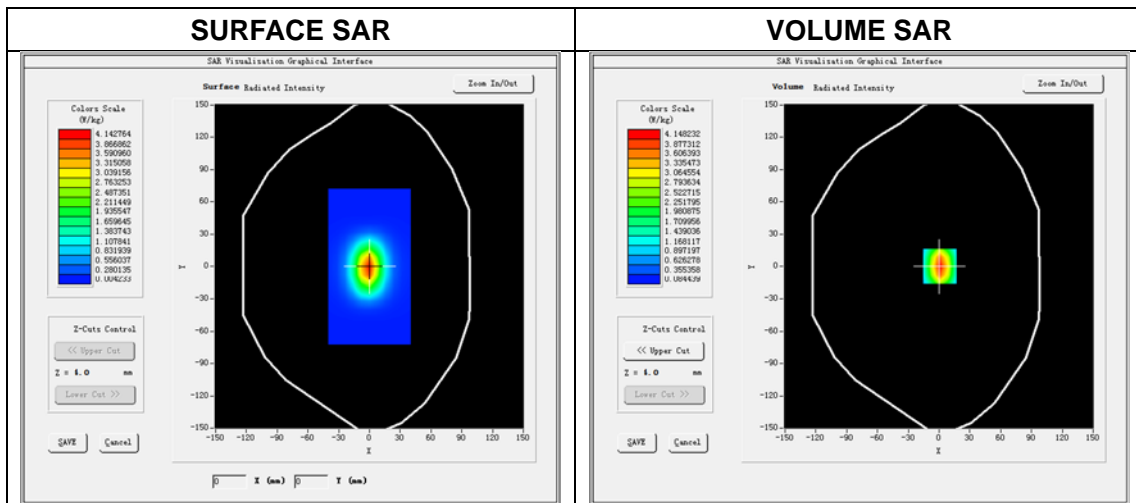

Maximum location: X=2.00, Y=-1.00

SAR Peak: 6.64W/kg

SAR 10g (W/Kg)	2.001651
SAR 1g (W/Kg)	3.943225

Z Axis Scan

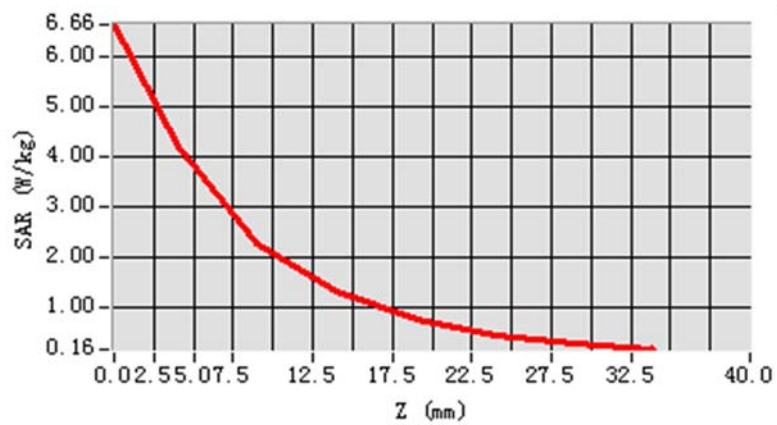

3D screen shot

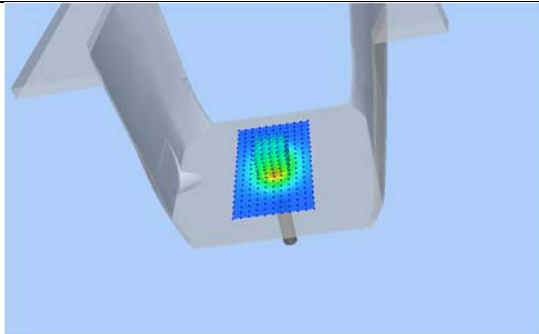

Hot spot position

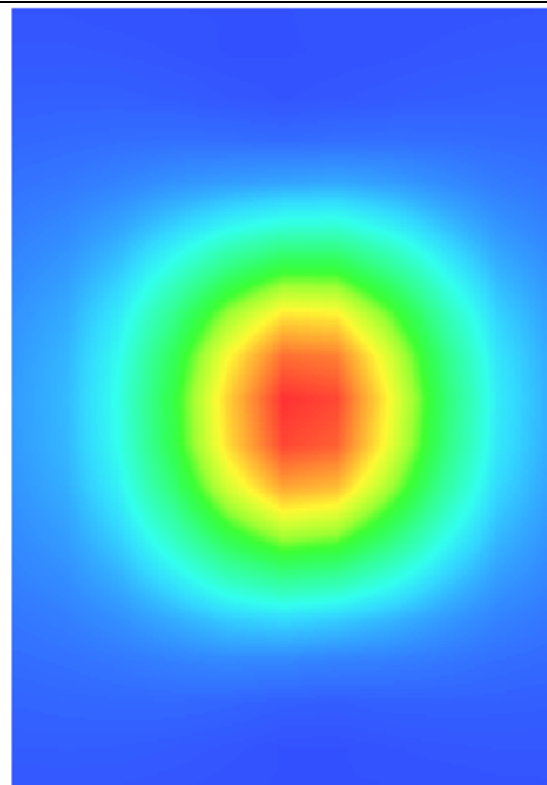

System Performance Check Data(2450MHz)

Type: Phone measurement (Complete)
 E-Field Probe: SN 34/15 SSE2 EPGO265
 Area scan resolution: dx=8mm,dy=8mm
 Zoom scan resolution: dx=5mm, dy=5mm, dz=5mm
 Date of measurement: 2019.09.09
 Measurement duration: 16 minutes 40 seconds

Experimental conditions.

Phantom File	surf_sam_plan.txt
Phantom	Validation plane
Band	2450MHz
Signal	CW
Frequency (MHz)	2450.000000
Relative permittivity (real part)	38.996721
Conductivity (S/m)	1.821367
Power drift (%)	-1.430000
Ambient Temperature:	22.5°C
Liquid Temperature:	21.1°C
ConvF:	2.55
Crest factor:	1:1

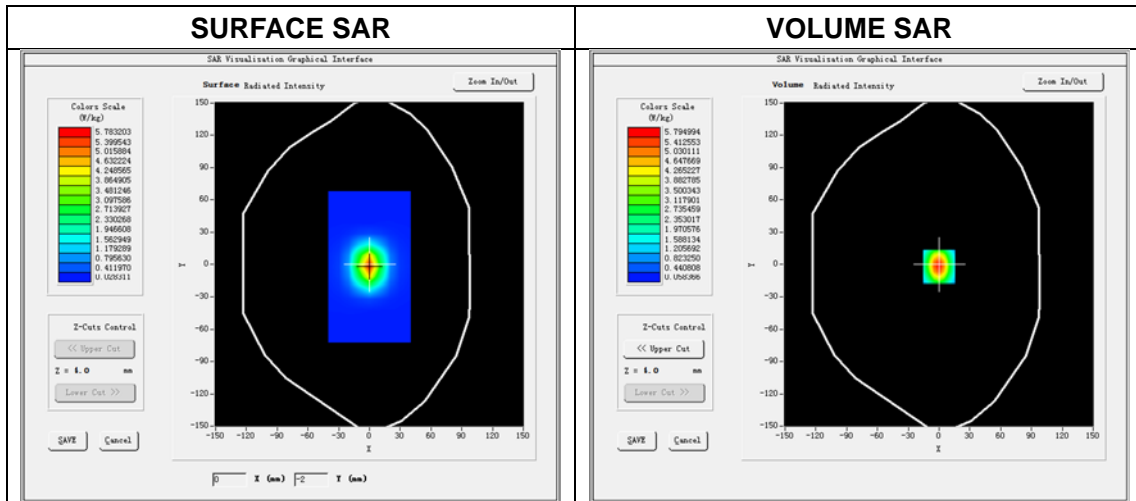

Maximum location: X=0.00, Y=-2.00
 SAR Peak: 9.87 W/kg

SAR 10g (W/Kg)	2.442824
SAR 1g (W/Kg)	5.329502

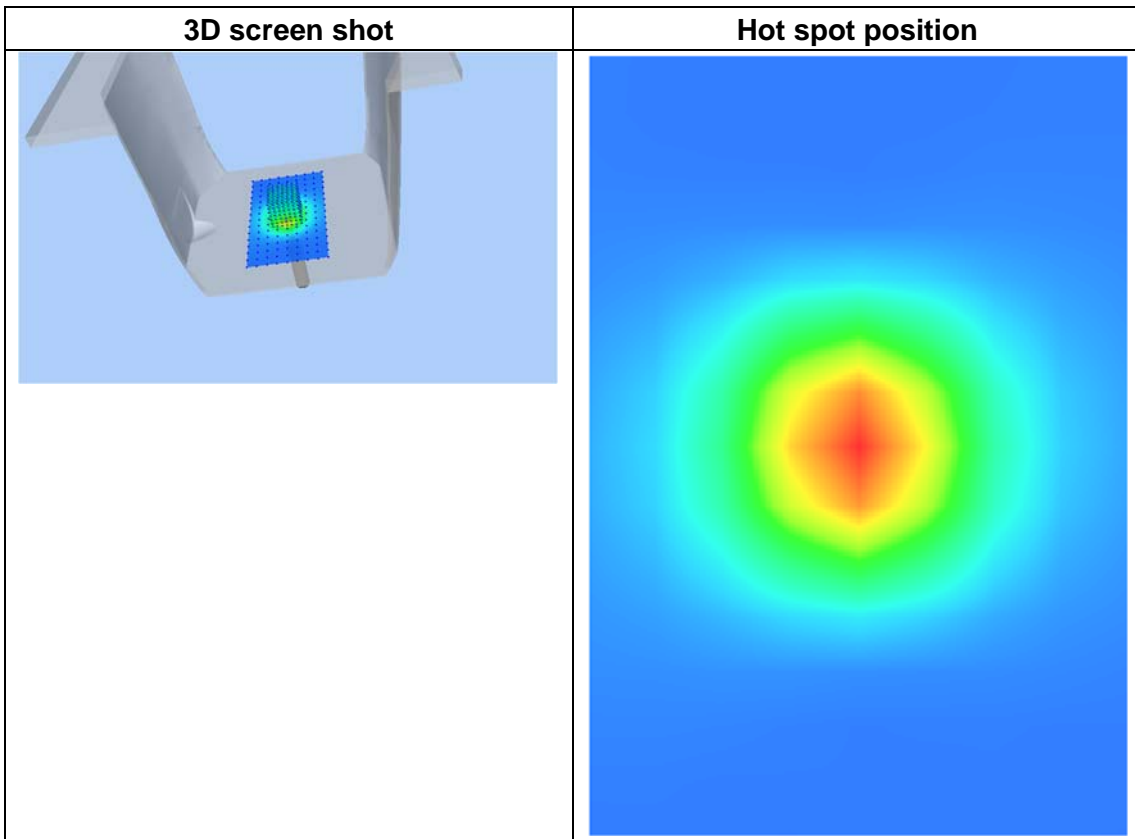
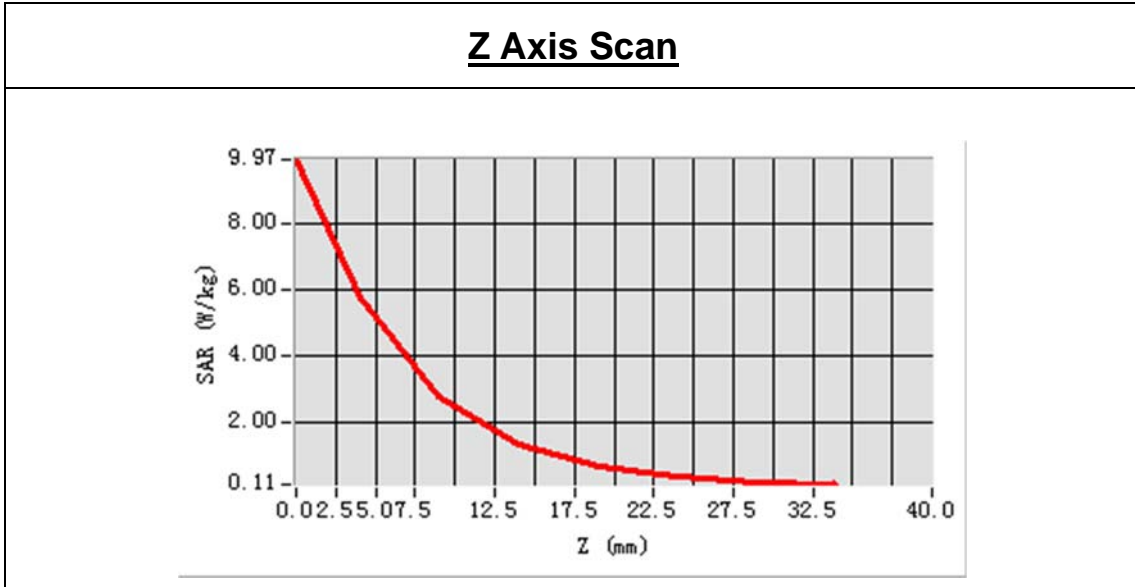

System Performance Check Data(2600MHz)

Type: Phone measurement (Complete)
 E-Field Probe: SN 34/15 SSE2 EPGO265
 Area scan resolution: dx=8mm,dy=8mm
 Zoom scan resolution: dx=5mm, dy=5mm, dz=5mm
 Date of measurement: 2019.09.08
 Measurement duration: 18 minutes39 seconds

Experimental conditions.

Phantom File	surf_sam_plan.txt
Phantom	Validation plane
Band	2600MHz
Signal	CW
Frequency (MHz)	2600.000000
Relative permittivity (real part)	38.318148
Conductivity (S/m)	1.991171
Power drift (%)	-0.370000
Ambient Temperature:	22.6°C
Liquid Temperature:	21.2°C
ConvF:	2.38
Crest factor:	1:1

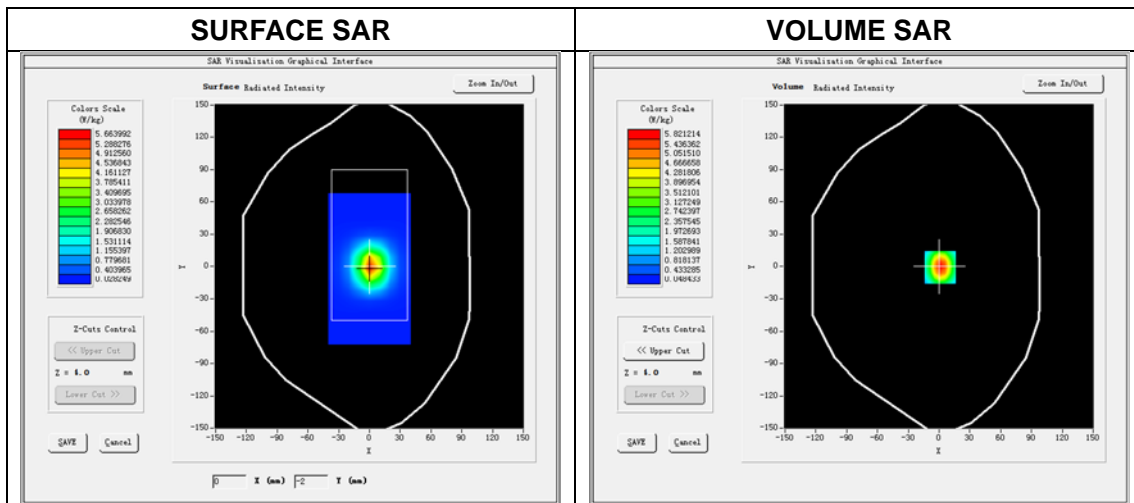

Maximum location: X=1.00, Y=-1.00
SAR Peak: 10.43 W/kg

SAR 10g (W/Kg)	2.378801
SAR 1g (W/Kg)	5.411161

Z Axis Scan

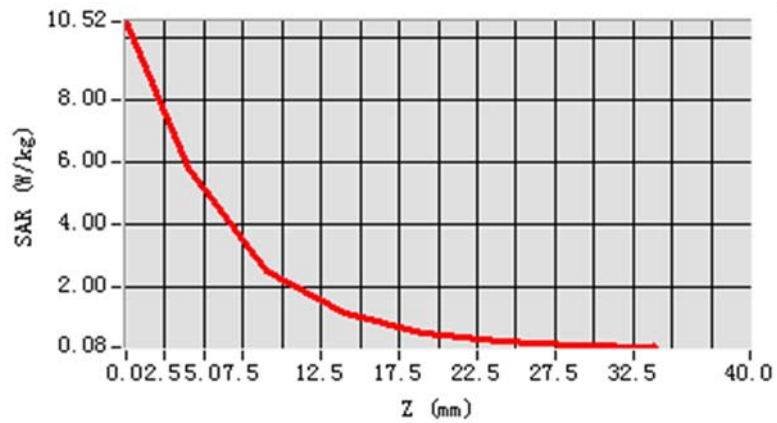

3D screen shot

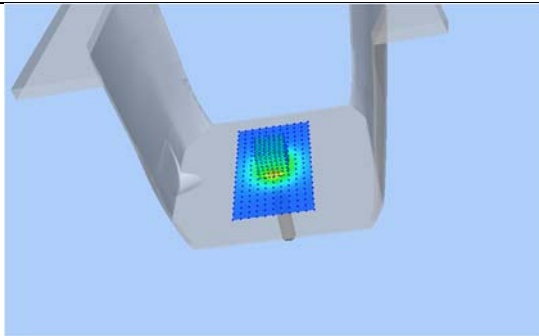

Hot spot position

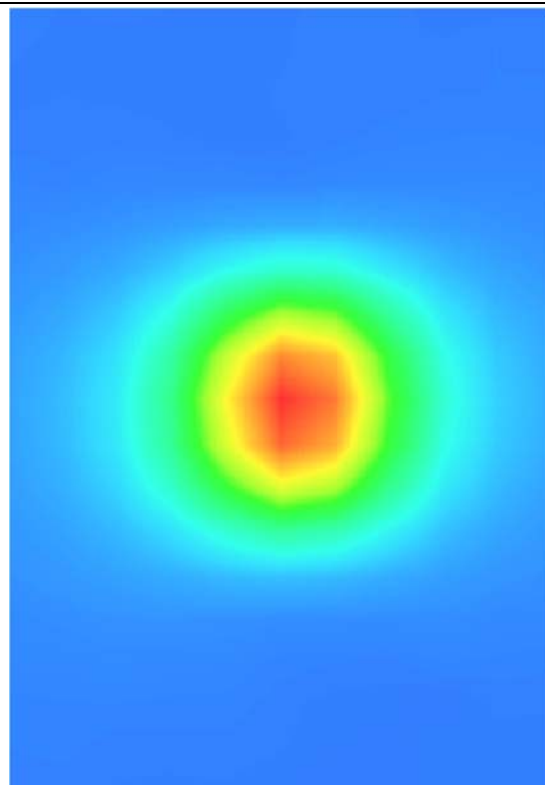

ANNEX C TEST DATA

MEAS. 1 Left Head with Cheek on High Channel in GPRS850-4Slots mode

Test Date:	12/9/2019
Measurement duration:	13 minutes 9 seconds
Signal:	GSM, f=848.8 MHz, Duty Cycle: 1:2.0
Liquid Parameters:	Permittivity: 40.94; Conductivity: 0.94 S/m
Test condition:	Ambient Temperature: 22.5°C, Liquid Temperature: 21.3°C
Probe:	SN 34/15 SSE2 EPGO265, ConvF: 1.93
Area Scan:	sam_direct_droit2_surf10mm.txt, h= 5.00 mm
Zoom Scan:	5x5x7,dx=8mm, dy=8mm, dz=5mm,Complete
Maximum location:	X=-46.000000, Y=-36.000000
SAR 10g (W/Kg):	0.552484
SAR 1g (W/Kg):	0.704446
Power drift (%):	-0.58
3D screen shot	

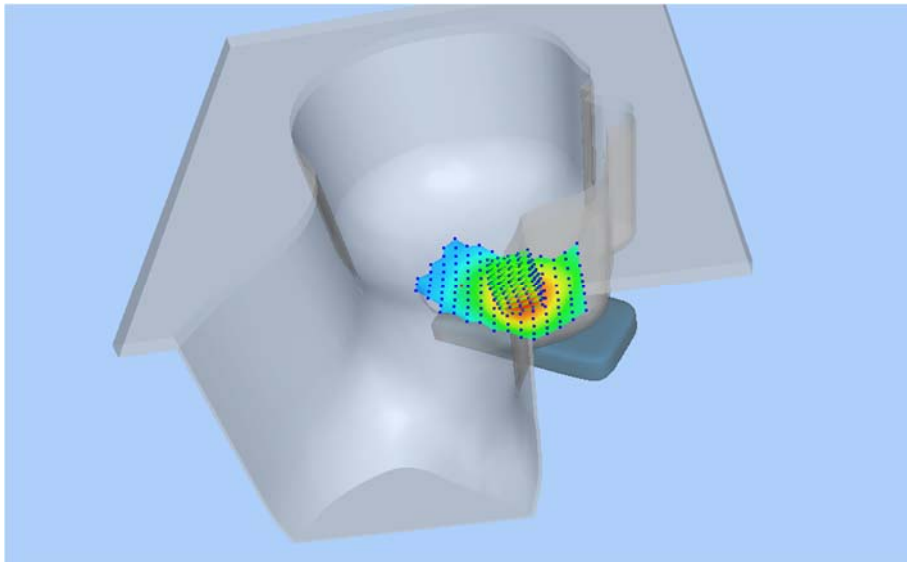

Z Axis Scan

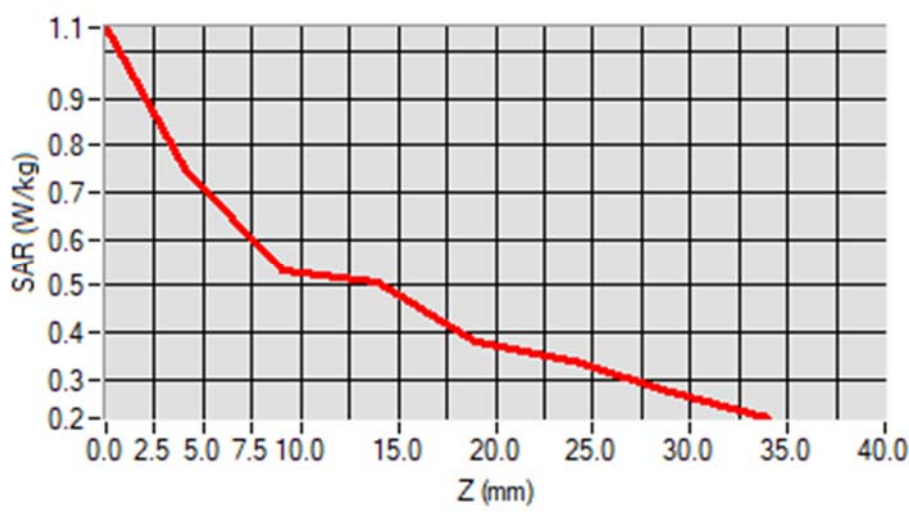

MEAS. 2 Body Plane with Back Side 10mm on High Channel in GPRS850-

4Slots mode

Test Date:	12/9/2019
Measurement duration:	12 minutes 28 seconds
Signal:	GSM, f=848.8 MHz, Duty Cycle: 1:2.0
Liquid Parameters:	Permittivity: 40.94; Conductivity: 0.94 S/m
Test condition:	Ambient Temperature: 22.5°C, Liquid Temperature: 21.3°C
Probe:	SN 34/15 SSE2 EPGO265, ConvF: 1.93
Area Scan:	sam_direct_droit2_surf10mm.txt, h= 5.00 mm
Zoom Scan:	5x5x7,dx=8mm, dy=8mm, dz=5mm,Complete
Maximum location:	X=0.000000, Y=8.000000
SAR 10g (W/Kg):	0.633575
SAR 1g (W/Kg):	0.866612
Power drift (%):	-3.63
3D screen shot	

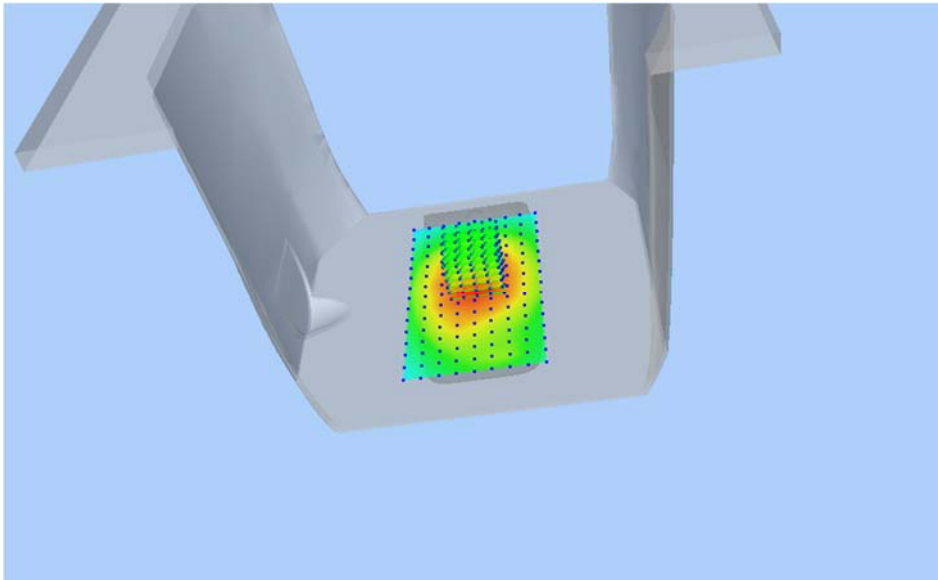

Z Axis Scan

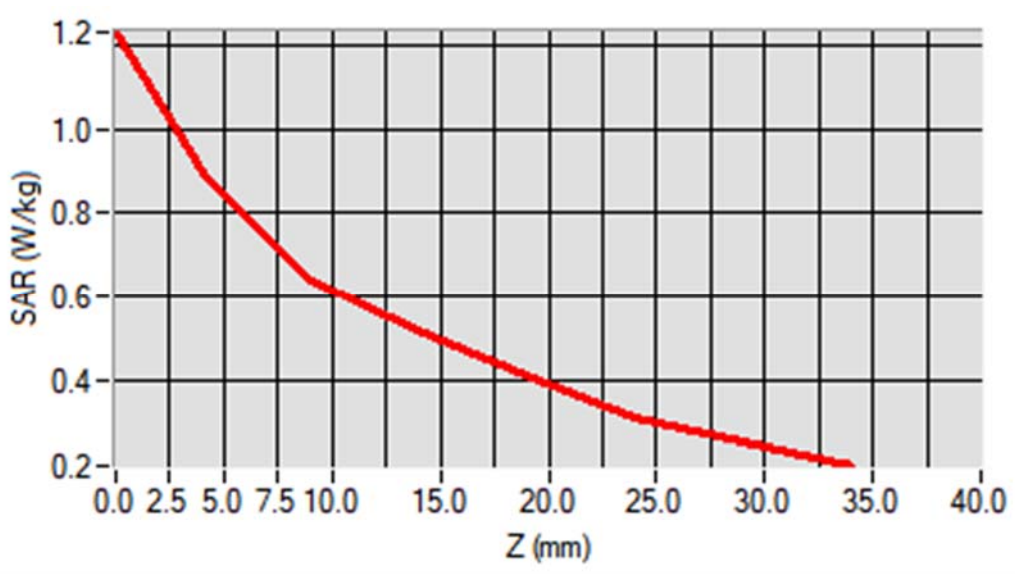

MEAS. 3 Left Head with Cheek on Low Channel in GPRS1900-4Solt mode

Test Date: 18/9/2019
Measurement duration: 12 minutes 9 seconds
Signal: GSM, f=1850.2 MHz, Duty Cycle: 1:2.0
Liquid Parameters: Permittivity: 41.09; Conductivity: 1.38 S/m
Test condition: Ambient Temperature: 22.4°C, Liquid Temperature: 21.2°C
Probe: SN 34/15 SSE2 EPGO265, ConvF: 2.46
Area Scan: sam_direct_droit2_surf10mm.txt, h= 5.00 mm
Zoom Scan: 5x5x7,dx=8mm, dy=8mm, dz=5mm,Complete
Maximum location: X=-56.000000, Y=-56.000000
SAR 10g (W/Kg): 0.108766
SAR 1g (W/Kg): 0.184919
Power drift (%): -3.94
3D screen shot

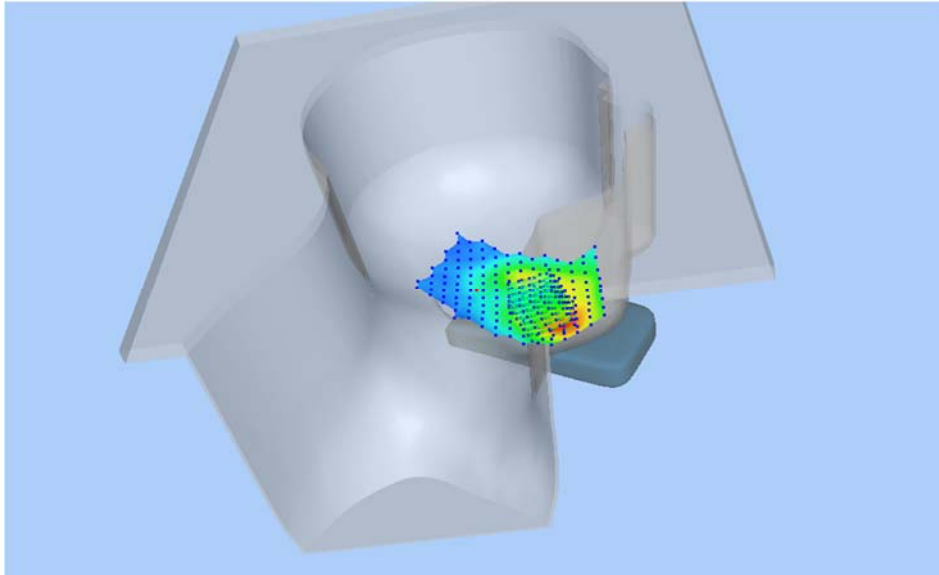

Z Axis Scan

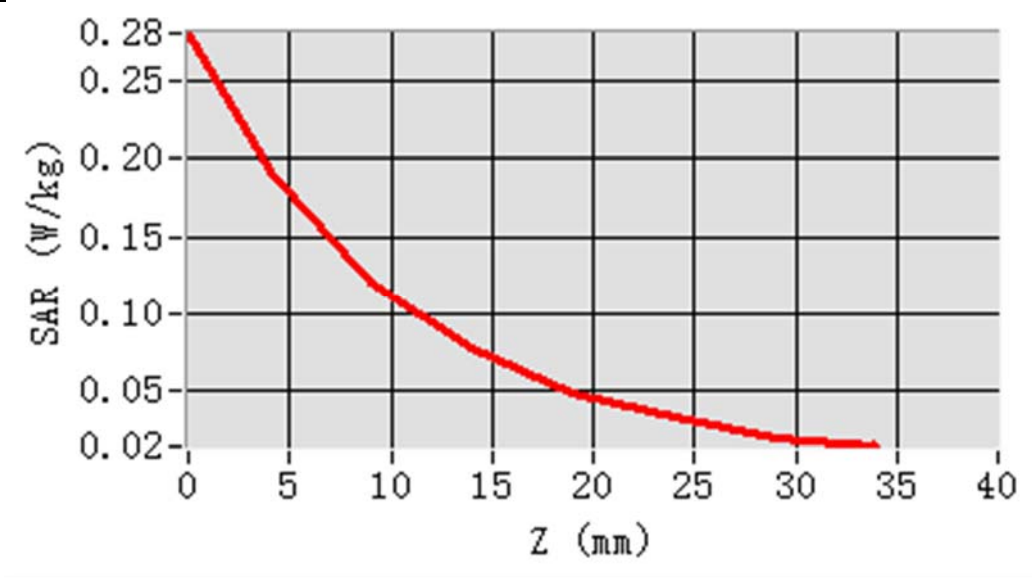

MEAS. 4 Body Plane with Back Side 10mm on Low Channel in GPRS1900-

4Solt mode

Test Date:	18/9/2019
Measurement duration:	11 minutes 0 seconds
Signal:	GSM, f=1850.2 MHz, Duty Cycle: 1:2.0
Liquid Parameters:	Permittivity: 41.09; Conductivity: 1.38 S/m
Test condition:	Ambient Temperature: 22.4°C, Liquid Temperature: 21.2°C
Probe:	SN 34/15 SSE2 EPGO265, ConvF: 2.46
Area Scan:	sam_direct_droit2_surf10mm.txt, h= 5.00 mm
Zoom Scan:	5x5x7,dx=8mm, dy=8mm, dz=5mm,Complete
Maximum location:	X=0.000000, Y=-42.000000
SAR 10g (W/Kg):	0.286020
SAR 1g (W/Kg):	0.505755
Power drift (%):	0.10
3D screen shot	

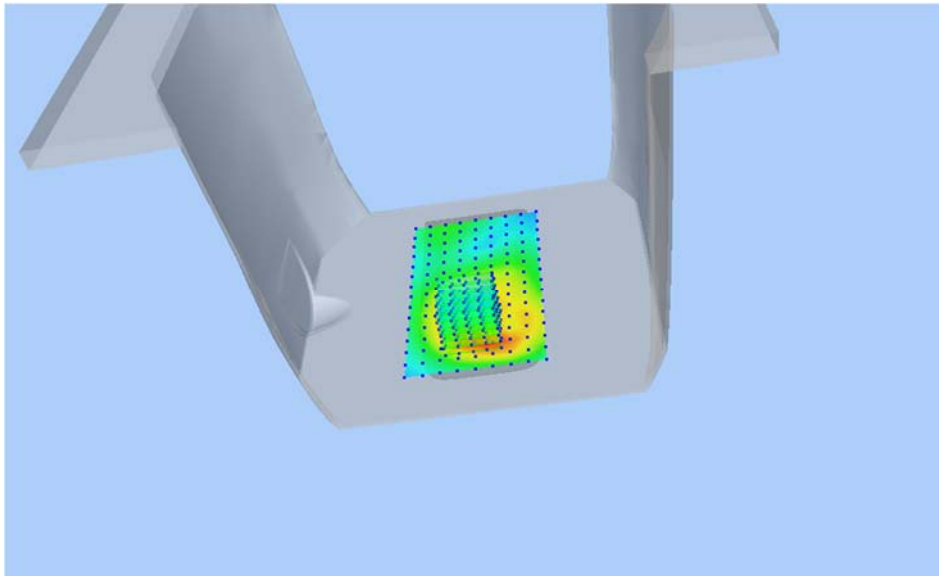

Z Axis Scan

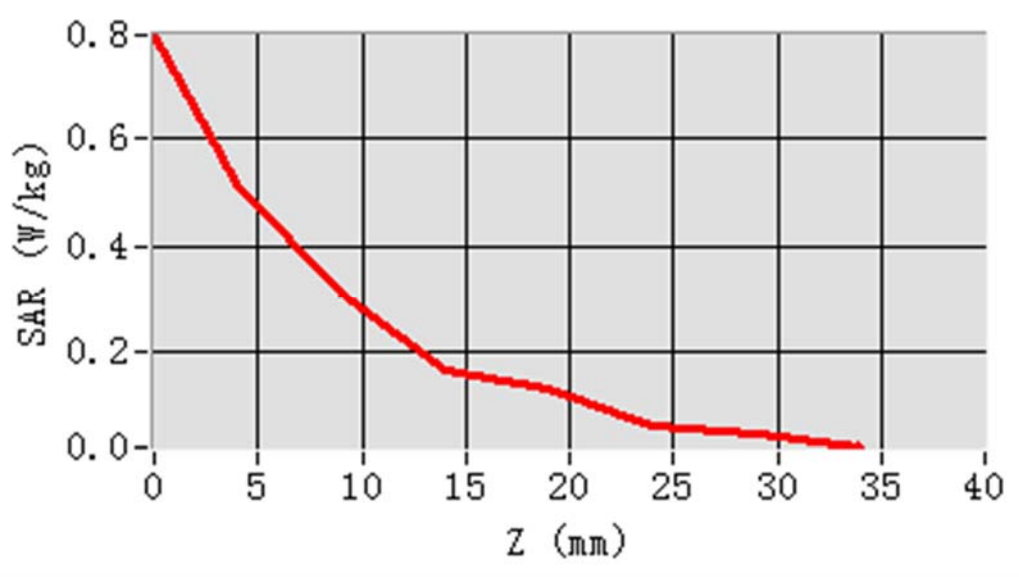

MEAS. 5 Left Head with Cheek on Middle Channel in WCDMA Band2 mode

Test Date: 17/9/2019
Measurement duration: 12 minutes 11 seconds
Signal: WCDMA, f=1880.0 MHz, Duty Cycle: 1:1.0
Liquid Parameters: Permittivity: 40.12; Conductivity: 1.36 S/m
Test condition: Ambient Temperature: 22.5°C, Liquid Temperature: 21.3°C
Probe: SN 34/15 SSE2 EPGO265, ConvF: 2.46
Area Scan: sam_direct_droit2_surf10mm.txt, h= 5.00 mm
Zoom Scan: 5x5x7,dx=8mm, dy=8mm, dz=5mm,Complete
Maximum location: X=-56.000000, Y=-56.000000
SAR 10g (W/Kg): 0.119348
SAR 1g (W/Kg): 0.202262
Power drift (%): -2.99
3D screen shot

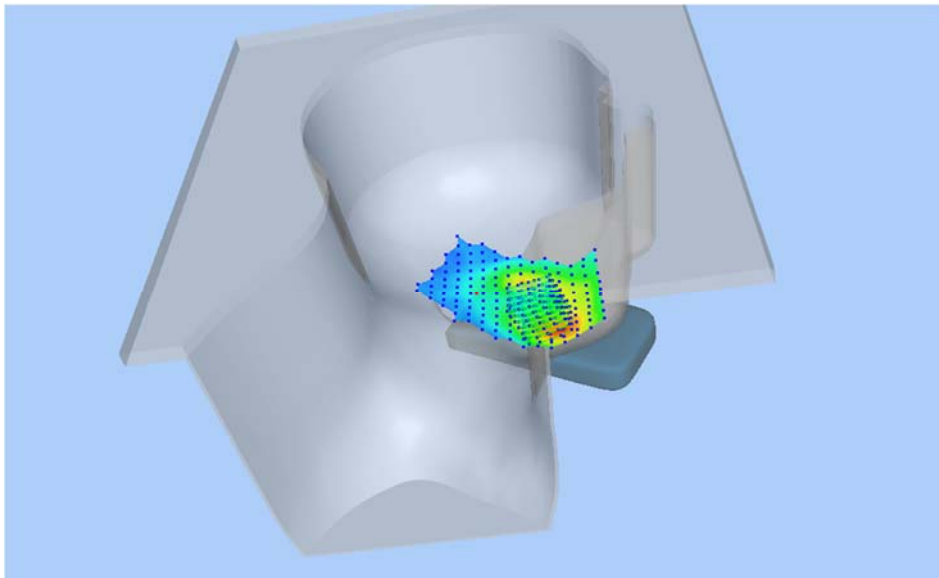

Z Axis Scan

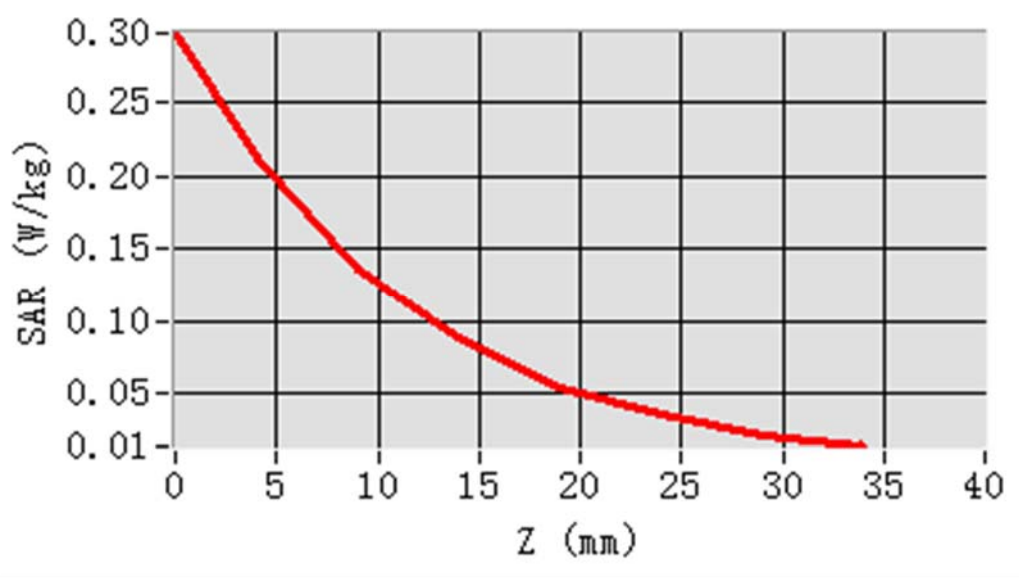

MEAS. 6 Body Plane with Back Side 10mm on Middle Channel in WCDMA

Band2 mode

Test Date:	17/9/2019
Measurement duration:	11 minutes 17 seconds
Signal:	WCDMA, f=1880.0 MHz, Duty Cycle: 1:1.0
Liquid Parameters:	Permittivity: 40.12; Conductivity: 1.36 S/m
Test condition:	Ambient Temperature: 22.5°C, Liquid Temperature: 21.3°C
Probe:	SN 34/15 SSE2 EPGO265, ConvF: 2.46
Area Scan:	sam_direct_droit2_surf10mm.txt, h= 5.00 mm
Zoom Scan:	5x5x7,dx=8mm, dy=8mm, dz=5mm,Complete
Maximum location:	X=10.000000, Y=-42.000000
SAR 10g (W/Kg):	0.312720
SAR 1g (W/Kg):	0.550098
Power drift (%):	-0.56
3D screen shot	

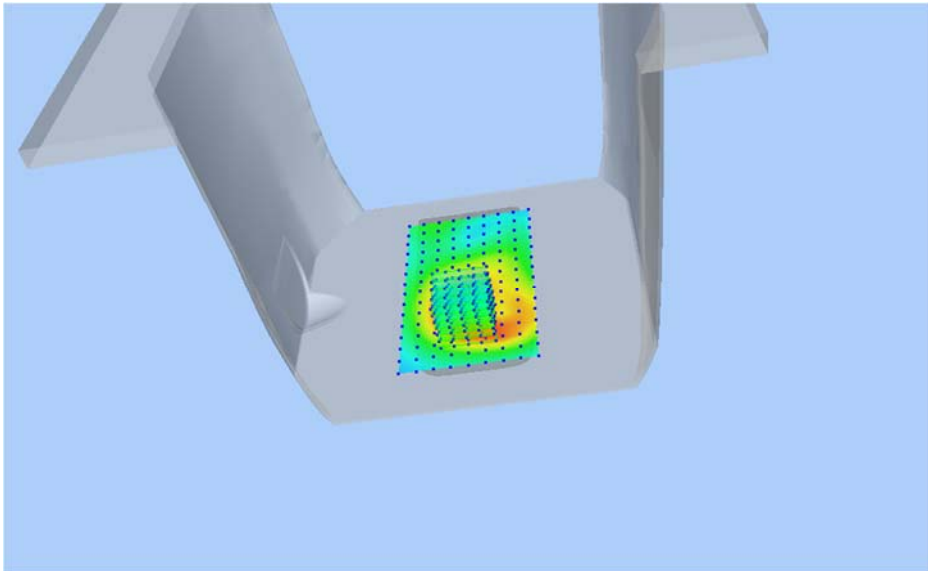

Z Axis Scan

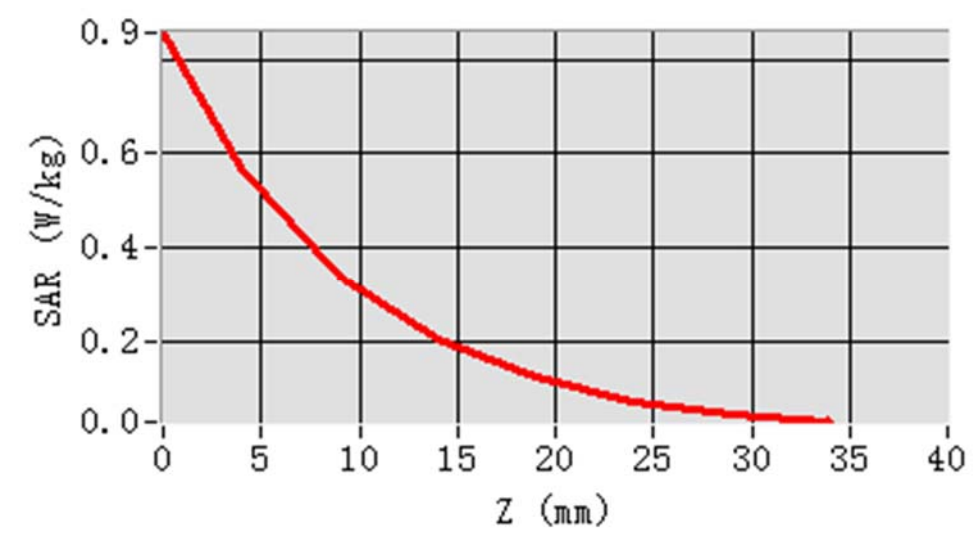

MEAS. 7 Left Head with Cheek on High Channel in WCDMA Band4 mode

Test Date: 16/9/2019
Measurement duration: 12 minutes 12 seconds
Signal: WCDMA, f=1752.6 MHz, Duty Cycle: 1:1.0
Liquid Parameters: Permittivity: 39.45; Conductivity: 1.38 S/m
Test condition: Ambient Temperature: 22.4°C, Liquid Temperature: 21.1°C
Probe: SN 34/15 SSE2 EPGO265, ConvF: 2.18
Area Scan: sam_direct_droit2_surf10mm.txt, h= 5.00 mm
Zoom Scan: 5x5x7,dx=8mm, dy=8mm, dz=5mm,Complete
Maximum location: X=-56.000000, Y=-56.000000
SAR 10g (W/Kg): 0.238102
SAR 1g (W/Kg): 0.401349
Power drift (%): -2.61
3D screen shot

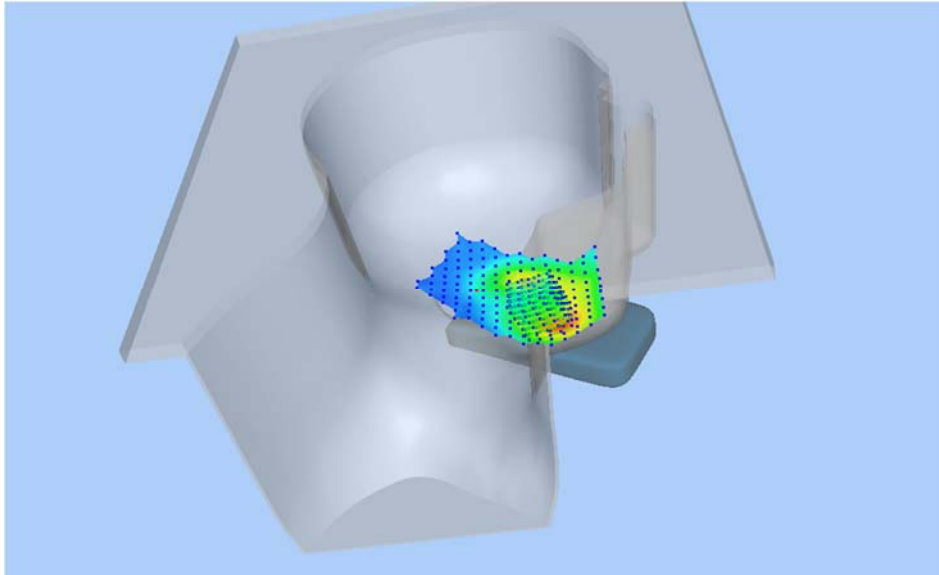

Z Axis Scan

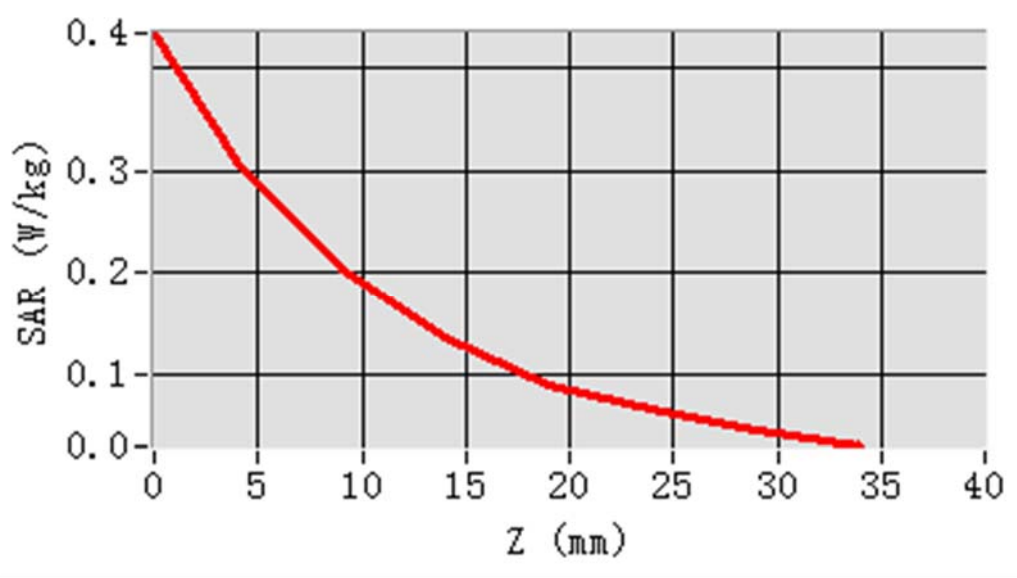

MEAS. 8 Body Plane with Back Side 10mm on Middle Channel in WCDMA

Band4 mode

Test Date:	16/9/2019
Measurement duration:	10 minutes 53 seconds
Signal:	WCDMA, f=1732.4 MHz, Duty Cycle: 1:1.0
Liquid Parameters:	Permittivity: 40.84; Conductivity: 1.34 S/m
Test condition:	Ambient Temperature: 22.4°C, Liquid Temperature: 21.1°C
Probe:	SN 34/15 SSE2 EPGO265, ConvF: 2.18
Area Scan:	sam_direct_droit2_surf10mm.txt, h= 5.00 mm
Zoom Scan:	5x5x7,dx=8mm, dy=8mm, dz=5mm,Complete
Maximum location:	X=0.000000, Y=-42.000000
SAR 10g (W/Kg):	0.547547
SAR 1g (W/Kg):	0.890644
Power drift (%):	-1.12
3D screen shot	

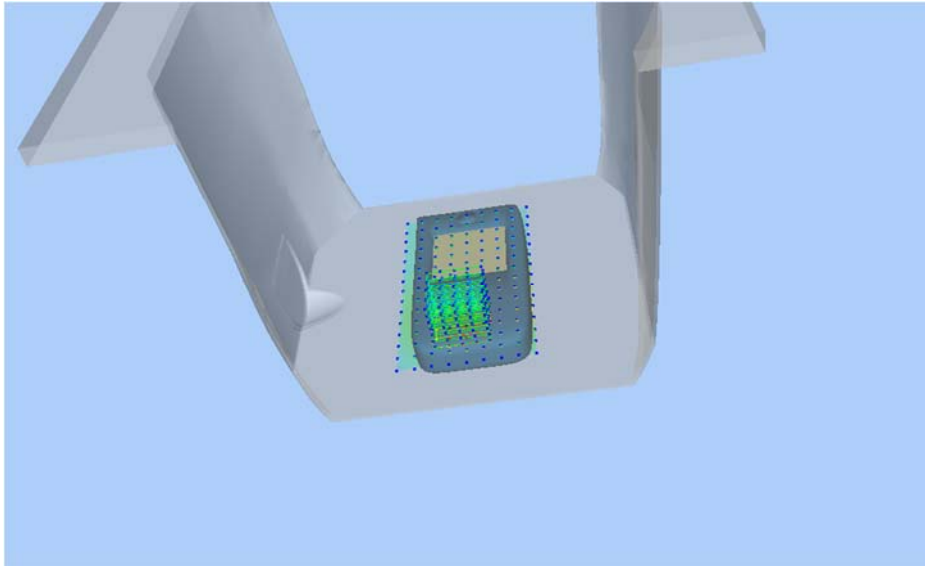

Z Axis Scan

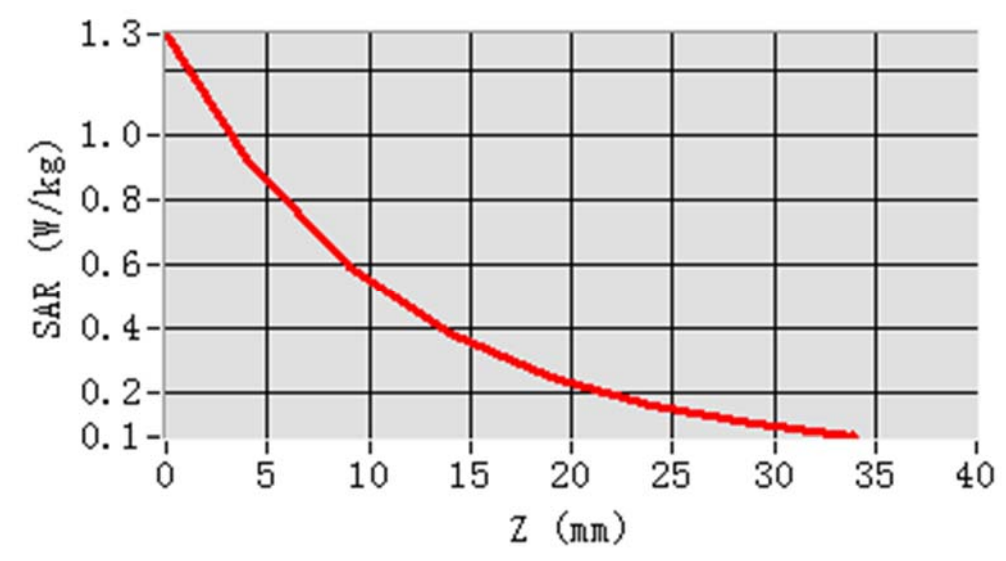

MEAS. 9 Left Head with Cheek on Low Channel in WCDMA Band5 mode

Test Date: 10/9/2019
Measurement duration: 14 minutes 15 seconds
Signal: WCDMA, f=826.4 MHz, Duty Cycle: 1:1.0
Liquid Parameters: Permittivity: 42.54; Conductivity: 0.88 S/m
Test condition: Ambient Temperature: 22.6°C, Liquid Temperature: 21.3°C
Probe: SN 34/15 SSE2 EPGO265, ConvF: 1.93
Area Scan: sam_direct_droit2_surf10mm.txt, h= 5.00 mm
Zoom Scan: 5x5x7,dx=8mm, dy=8mm, dz=5mm,Complete
Maximum location: X=-46.000000, Y=-26.000000
SAR 10g (W/Kg): 0.282216
SAR 1g (W/Kg): 0.355829
Power drift (%): -0.71
3D screen shot

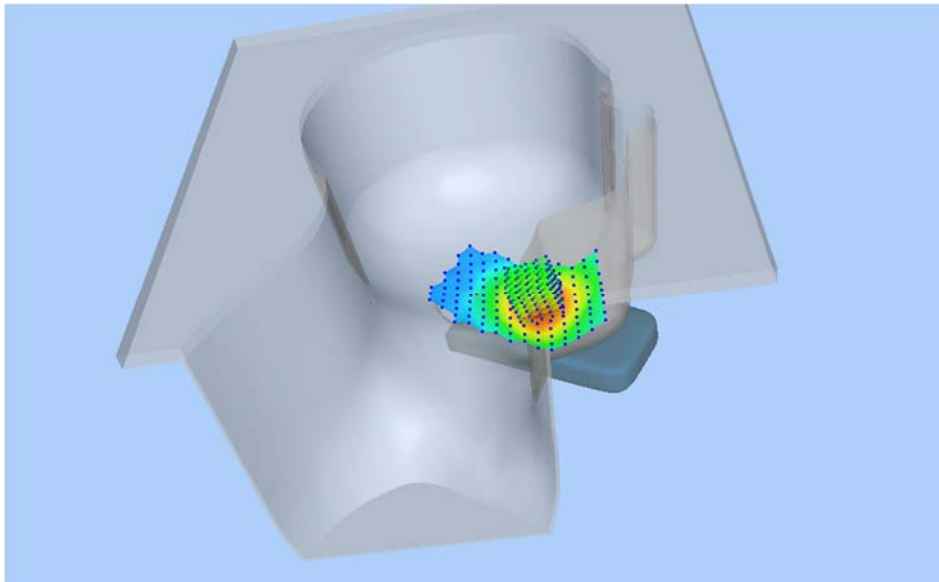

Z Axis Scan

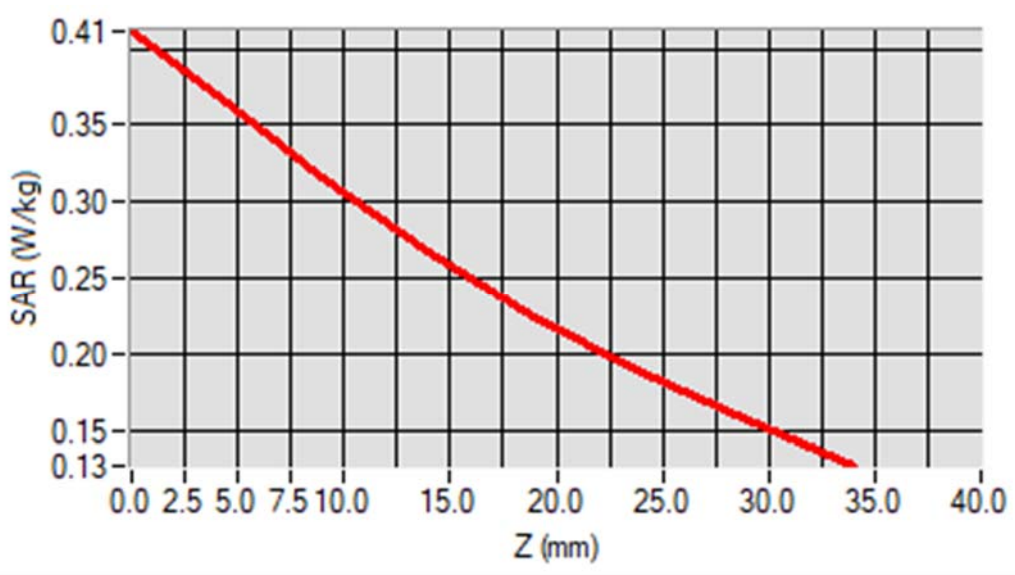

MEAS. 10 Body Plane with Back Side 10mm on Low Channel in WCDMA

Band5 mode

Test Date:	10/9/2019
Measurement duration:	12 minutes 13 seconds
Signal:	WCDMA, f=826.4 MHz, Duty Cycle: 1:1.0
Liquid Parameters:	Permittivity: 42.54; Conductivity: 0.88 S/m
Test condition:	Ambient Temperature: 22.6°C, Liquid Temperature: 21.3°C
Probe:	SN 34/15 SSE2 EPGO265, ConvF: 1.93
Area Scan:	sam_direct_droit2_surf10mm.txt, h= 5.00 mm
Zoom Scan:	5x5x7,dx=8mm, dy=8mm, dz=5mm,Complete
Maximum location:	X=0.000000, Y=-2.000000
SAR 10g (W/Kg):	0.352461
SAR 1g (W/Kg):	0.463540
Power drift (%):	-0.31
3D screen shot	

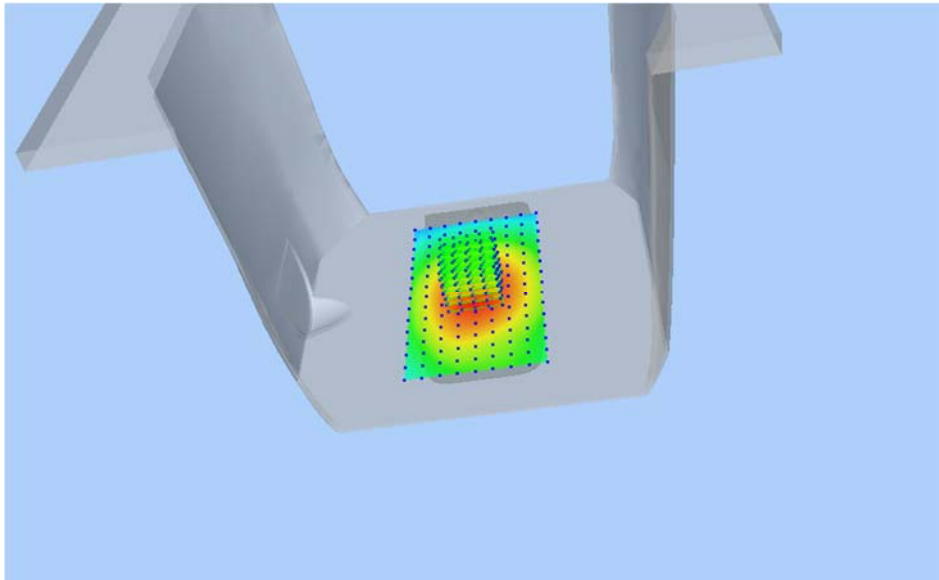

Z Axis Scan

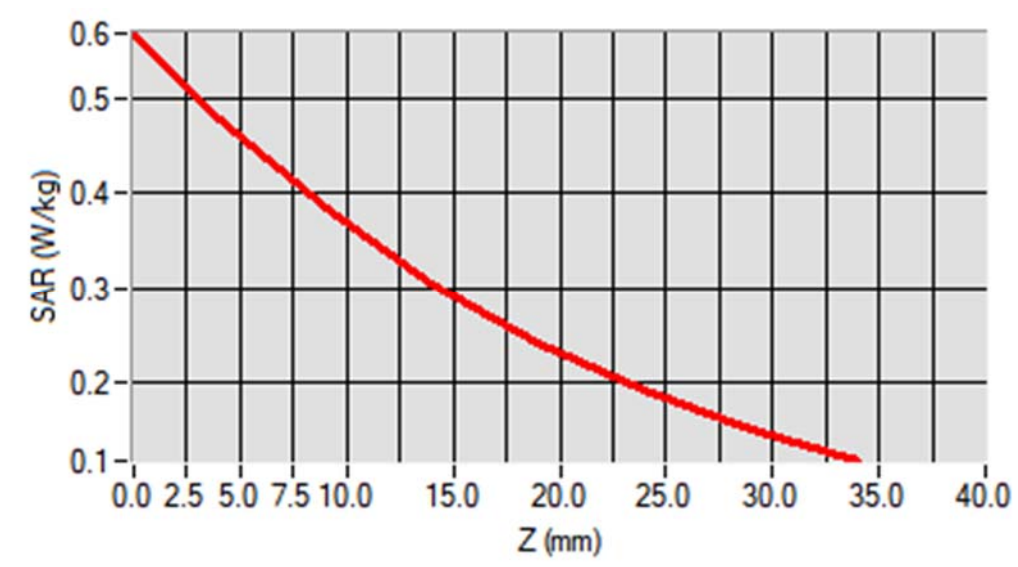

MEAS. 11 Left Head with Cheek on Middle Channel in LTE Band2 mode

Test Date: 17/9/2019
Measurement duration: 12 minutes 11 seconds
Signal: LTE, f=1880 MHz, Duty Cycle: 1:1.0
Liquid Parameters: Permittivity: 40.12; Conductivity: 1.36 S/m
Test condition: Ambient Temperature: 22.5°C, Liquid Temperature: 21.3°C
Probe: SN 34/15 SSE2 EPGO265, ConvF: 2.46
Area Scan: sam_direct_droit2_surf10mm.txt, h= 5.00 mm
Zoom Scan: 5x5x7,dx=8mm, dy=8mm, dz=5mm,Complete
Maximum location: X=-56.000000, Y=-56.000000
SAR 10g (W/Kg): 0.136779
SAR 1g (W/Kg): 0.234014
Power drift (%): -1.31
3D screen shot

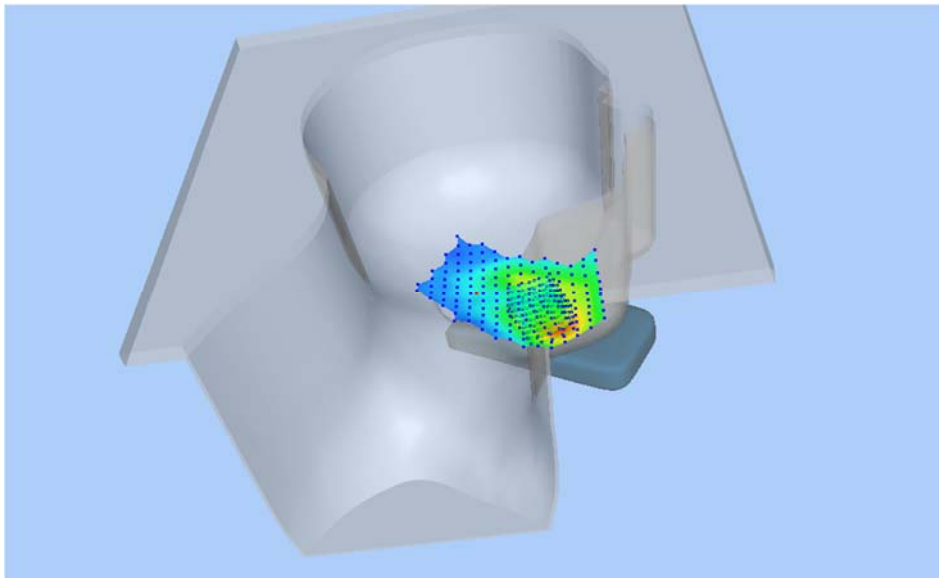

Z Axis Scan

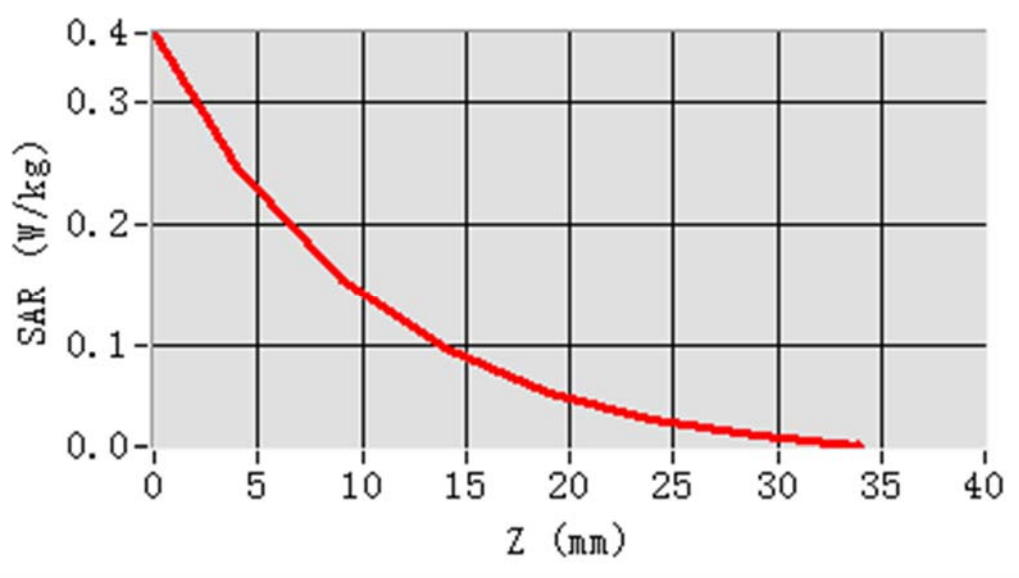

MEAS. 12 Body Plane with Back Side 10mm on Middle Channel in LTE Band2

mode

Test Date: 17/9/2019
Measurement duration: 11 minutes 12 seconds
Signal: LTE, f=1880 MHz, Duty Cycle: 1:1.0
Liquid Parameters: Permittivity: 40.12; Conductivity: 1.36 S/m
Test condition: Ambient Temperature: 22.5°C, Liquid Temperature: 21.3°C
Probe: SN 34/15 SSE2 EPGO265, ConvF: 2.46
Area Scan: sam_direct_droit2_surf10mm.txt, h= 5.00 mm
Zoom Scan: 5x5x7,dx=8mm, dy=8mm, dz=5mm,Complete
Maximum location: X=0.000000, Y=-32.000000
SAR 10g (W/Kg): 0.283438
SAR 1g (W/Kg): 0.480831
Power drift (%): -1.21
3D screen shot

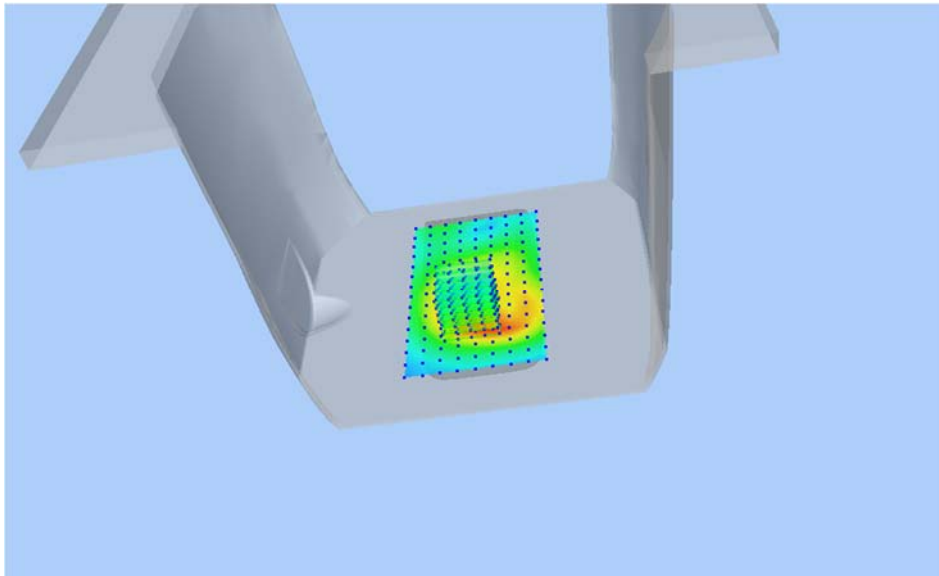

Z Axis Scan

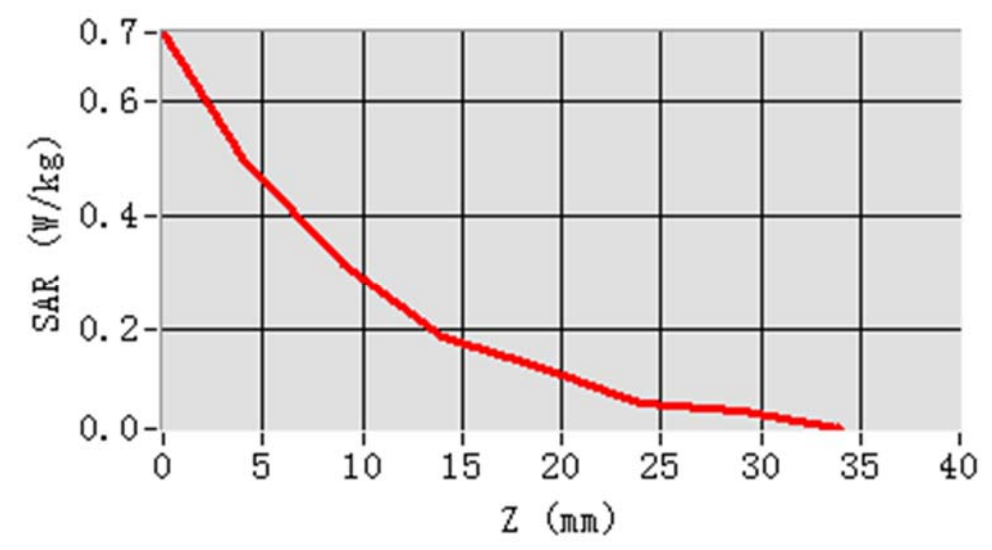

MEAS. 13 Left Head with Cheek on Middle Channel in LTE Band4 mode

Test Date: 16/9/2019
Measurement duration: 11 minutes 24 seconds
Signal: LTE, f=1732.5 MHz, Duty Cycle: 1:1.0
Liquid Parameters: Permittivity: 40.84; Conductivity: 1.34 S/m
Test condition: Ambient Temperature: 22.4°C, Liquid Temperature: 21.1°C
Probe: SN 34/15 SSE2 EPGO265, ConvF: 2.18
Area Scan: sam_direct_droit2_surf10mm.txt, h= 5.00 mm
Zoom Scan: 5x5x7,dx=8mm, dy=8mm, dz=5mm,Complete
Maximum location: X=-46.000000, Y=-46.000000
SAR 10g (W/Kg): 0.322216
SAR 1g (W/Kg): 0.537474
Power drift (%): -2.03
3D screen shot

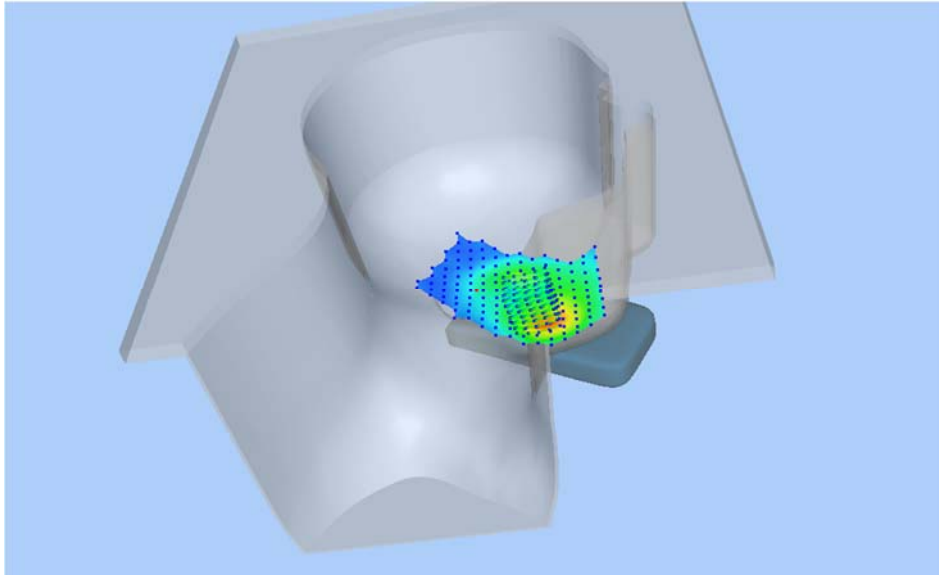

Z Axis Scan

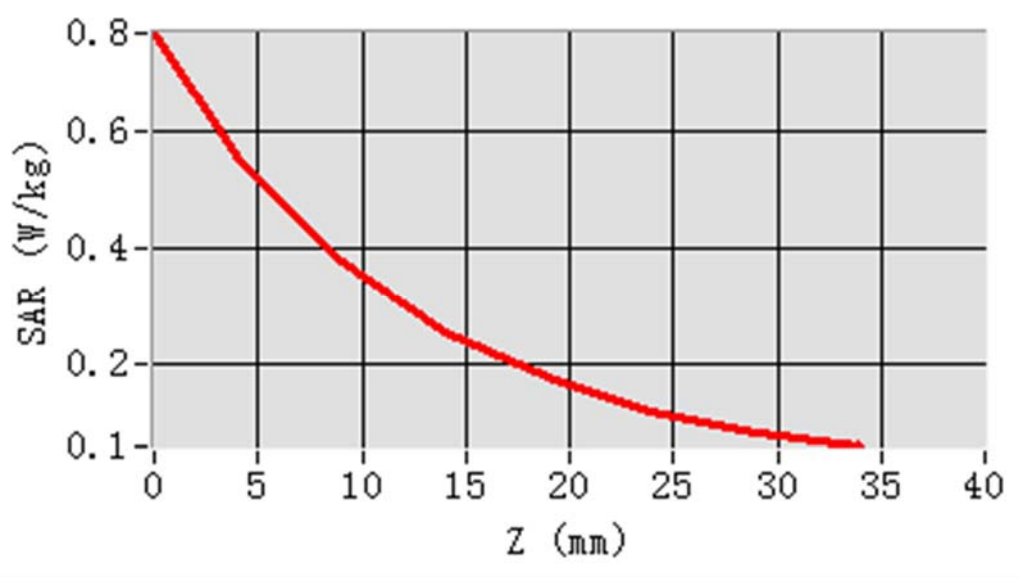

MEAS. 14 Body Plane with Back Side 10mm on Middle Channel in LTE Band4

mode

Test Date:	16/9/2019
Measurement duration:	11 minutes 18 seconds
Signal:	LTE, f=1732.5 MHz, Duty Cycle: 1:1.0
Liquid Parameters:	Permittivity: 40.84; Conductivity: 1.34 S/m
Test condition:	Ambient Temperature: 22.4°C, Liquid Temperature: 21.1°C
Probe:	SN 34/15 SSE2 EPGO265, ConvF: 2.18
Area Scan:	sam_direct_droit2_surf10mm.txt, h= 5.00 mm
Zoom Scan:	5x5x7,dx=8mm, dy=8mm, dz=5mm,Complete
Maximum location:	X=0.000000, Y=-22.000000
SAR 10g (W/Kg):	0.433506
SAR 1g (W/Kg):	0.701374
Power drift (%):	-0.02
3D screen shot	

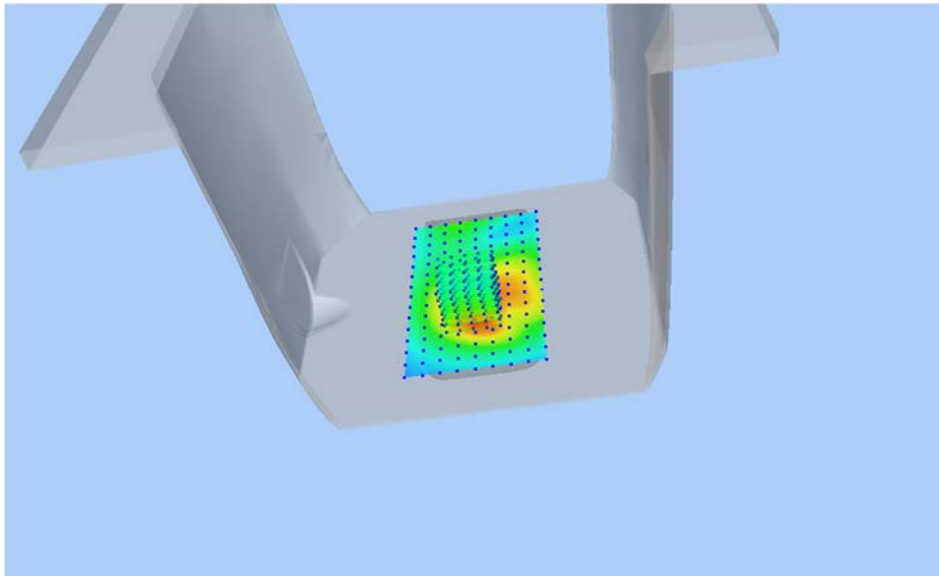

Z Axis Scan

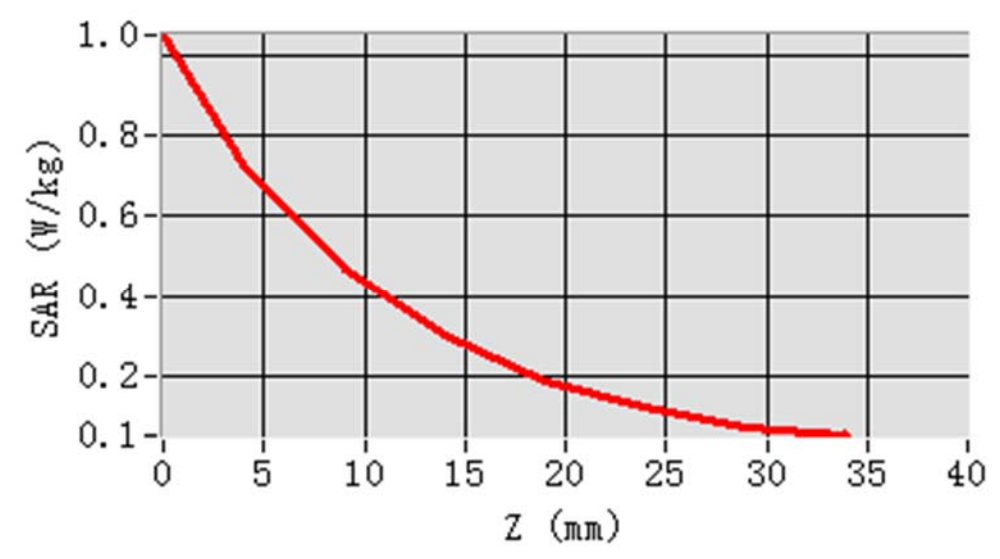

MEAS. 15 Left Head with Cheek on Middle Channel in LTE Band5 mode

Test Date: 10/9/2019
Measurement duration: 11 minutes 32 seconds
Signal: LTE, f=836.5 MHz, Duty Cycle: 1:1.0
Liquid Parameters: Permittivity: 42.04; Conductivity: 0.92 S/m
Test condition: Ambient Temperature: 22.6°C, Liquid Temperature: 21.3°C
Probe: SN 34/15 SSE2 EPGO265, ConvF: 1.93
Area Scan: sam_direct_droit2_surf10mm.txt, h= 5.00 mm
Zoom Scan: 5x5x7,dx=8mm, dy=8mm, dz=5mm,Complete
Maximum location: X=-46.000000, Y=-26.000000
SAR 10g (W/Kg): 0.355989
SAR 1g (W/Kg): 0.456630
Power drift (%): -1.20
3D screen shot

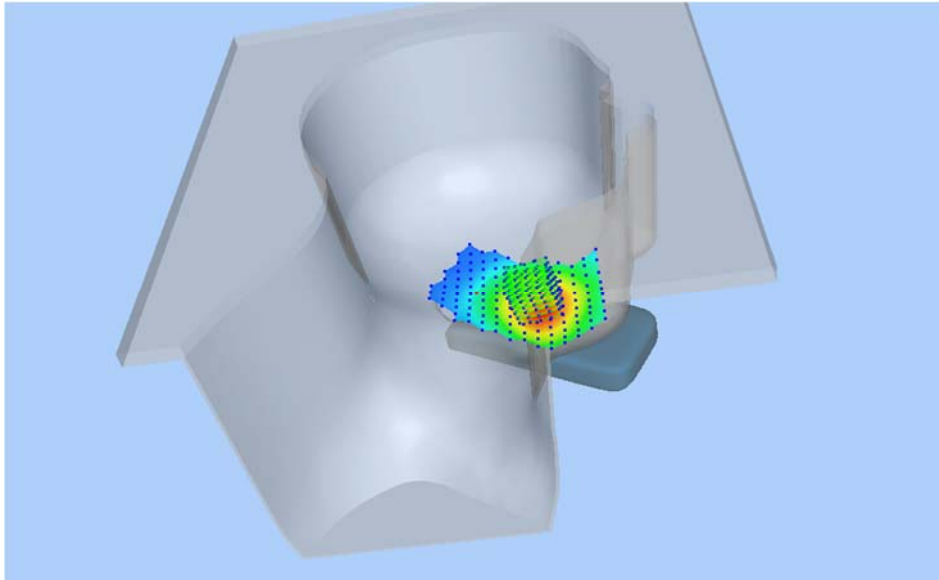

Z Axis Scan

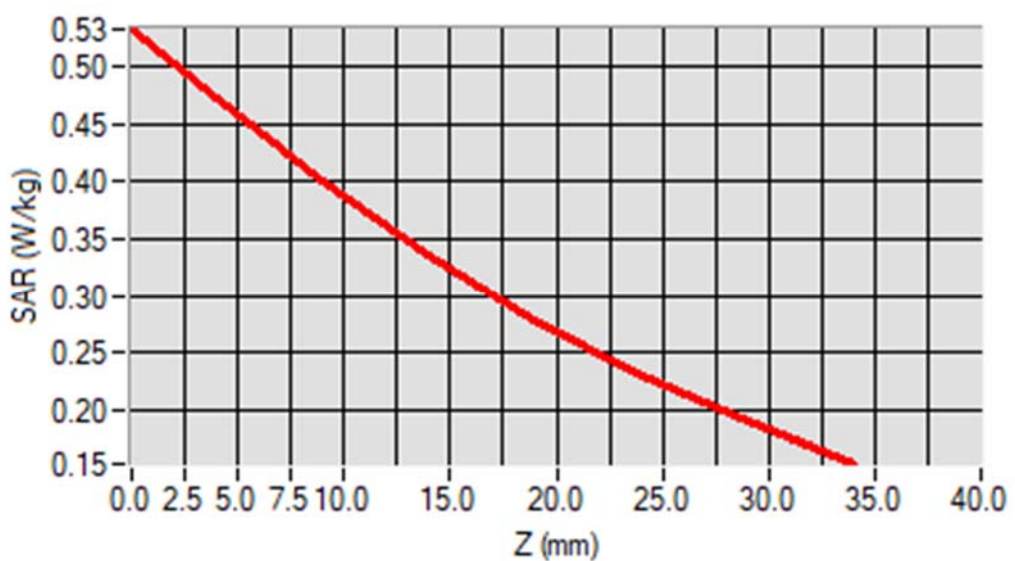

MEAS. 16 Body Plane with Back Side 10mm on Middle Channel in LTE Band5

mode

Test Date: 10/9/2019
Measurement duration: 13 minutes 11 seconds
Signal: LTE, f=836.5 MHz, Duty Cycle: 1:1.0
Liquid Parameters: Permittivity: 42.04; Conductivity: 0.92 S/m
Test condition: Ambient Temperature: 22.6°C, Liquid Temperature: 21.3°C
Probe: SN 34/15 SSE2 EPGO265, ConvF: 1.93
Area Scan: sam_direct_droit2_surf10mm.txt, h= 5.00 mm
Zoom Scan: 5x5x7,dx=8mm, dy=8mm, dz=5mm,Complete
Maximum location: X=10.000000, Y=-2.000000
SAR 10g (W/Kg): 0.454843
SAR 1g (W/Kg): 0.597342
Power drift (%): -0.72
3D screen shot

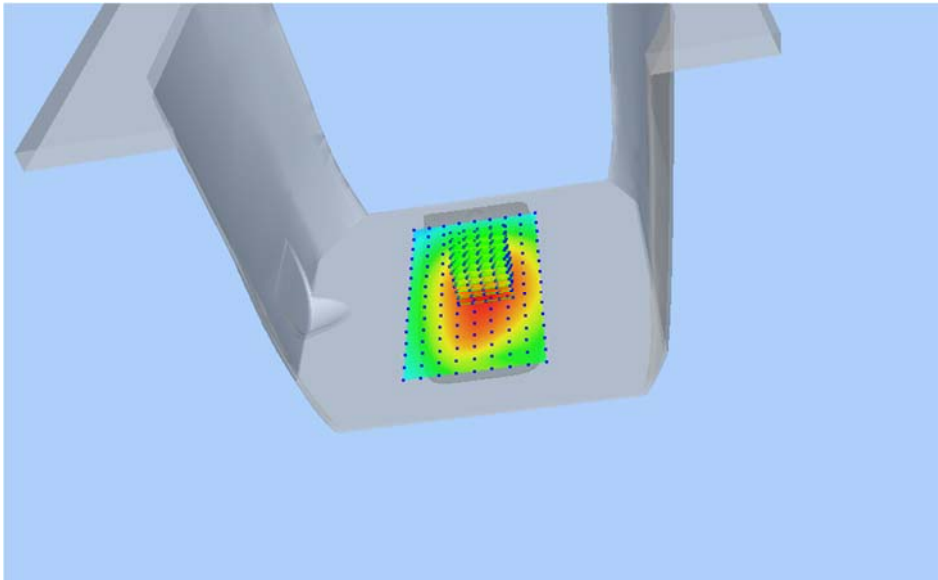

Z Axis Scan

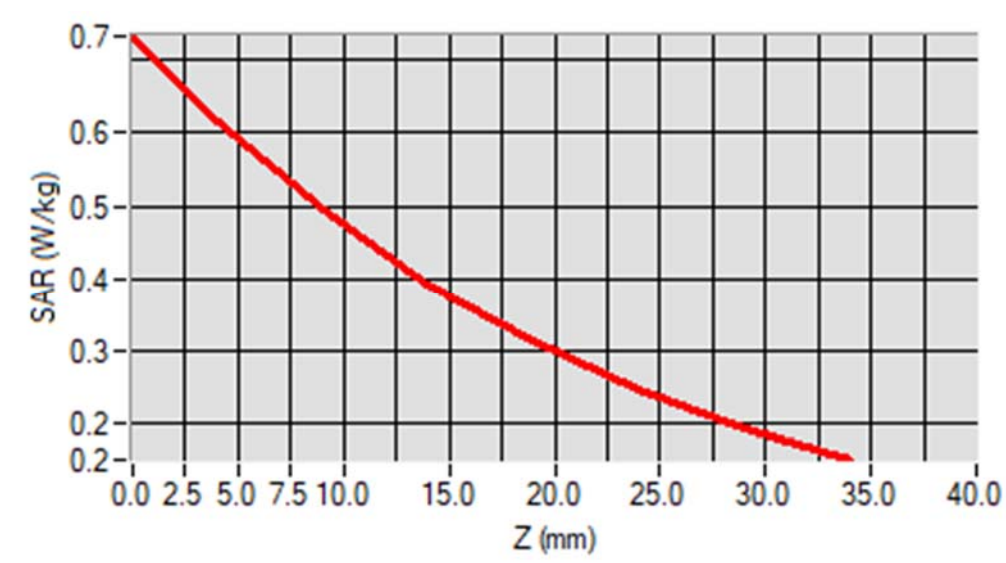

MEAS. 17 Left Head with Cheek on Low Channel in LTE Band7 mode

Test Date: 8/9/2019
Measurement duration: 16 minutes 4 seconds
Signal: LTE, f=2510.0 MHz, Duty Cycle: 1:1.0
Liquid Parameters: Permittivity: 39.98; Conductivity: 1.84 S/m
Test condition: Ambient Temperature: 22.6°C, Liquid Temperature: 21.2°C
Probe: SN 34/15 SSE2 EPGO265, ConvF: 2.38
Area Scan: sam_direct_droit2_surf10mm.txt, h= 5.00 mm
Zoom Scan: 7x7x7,dx=5mm, dy=5mm, dz=5mm,Complete
Maximum location: X=-46.000000, Y=-46.000000
SAR 10g (W/Kg): 0.052448
SAR 1g (W/Kg): 0.106082
Power drift (%): -1.25
3D screen shot

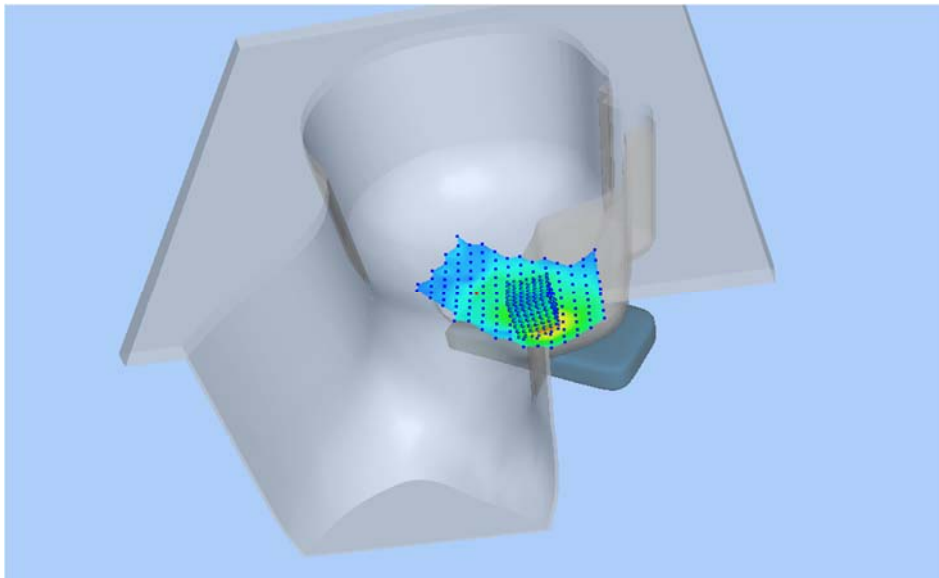

Z Axis Scan

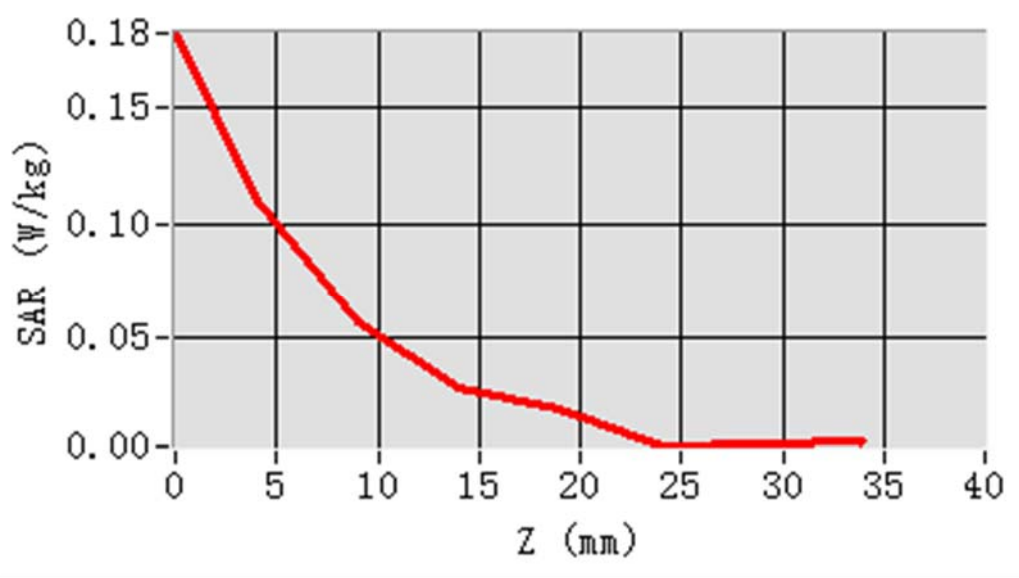

MEAS. 18 Body Plane with Back Side 10mm on Low Channel in LTE Band7

mode

Test Date: 8/9/2019
Measurement duration: 16 minutes 4 seconds
Signal: LTE, f=2510.0 MHz, Duty Cycle: 1:1.0
Liquid Parameters: Permittivity: 39.98; Conductivity: 1.84 S/m
Test condition: Ambient Temperature: 22.6°C, Liquid Temperature: 21.2°C
Probe: SN 34/15 SSE2 EPGO265, ConvF: 2.38
Area Scan: sam_direct_droit2_surf10mm.txt, h= 5.00 mm
Zoom Scan: 7x7x7,dx=5mm, dy=5mm, dz=5mm,Complete
Maximum location: X=0.000000, Y=-32.000000
SAR 10g (W/Kg): 0.078776
SAR 1g (W/Kg): 0.182905
Power drift (%): -1.09
3D screen shot

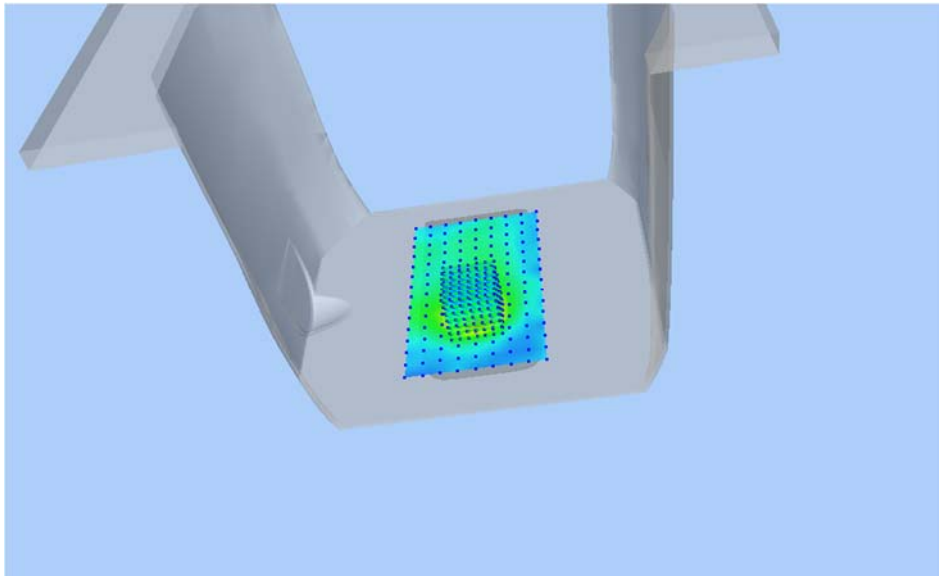

Z Axis Scan

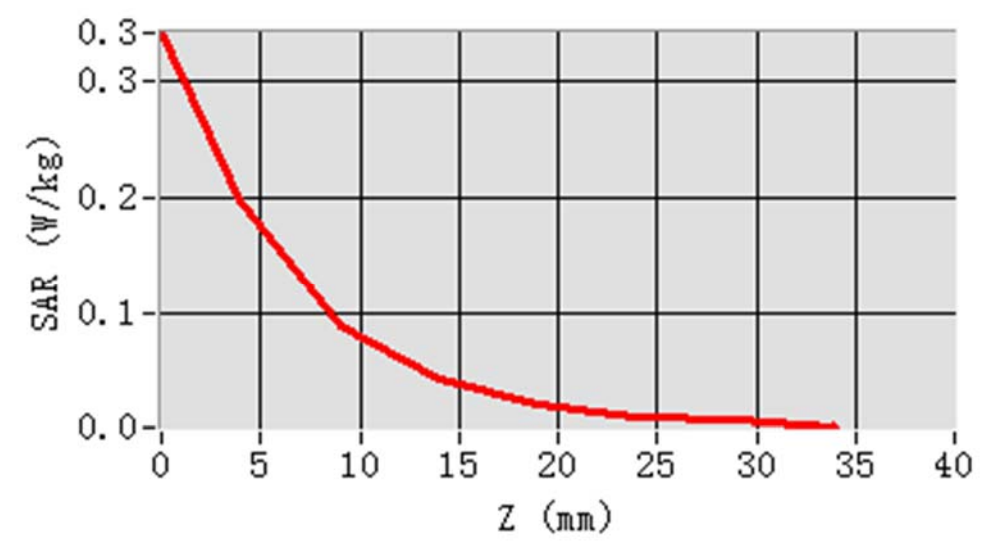

MEAS. 19 Right Head with Cheek on Middle Channel in LTE Band12 mode

Test Date: 11/9/2019
Measurement duration: 12 minutes 16 seconds
Signal: LTE, f=707.5 MHz, Duty Cycle: 1:1.0
Liquid Parameters: Permittivity: 43.25; Conductivity: 0.89 S/m
Test condition: Ambient Temperature: 22.7°C, Liquid Temperature: 21.4°C
Probe: SN 34/15 SSE2 EPGO265, ConvF: 1.89
Area Scan: sam_direct_droit2_surf10mm.txt, h= 5.00 mm
Zoom Scan: 5x5x7,dx=8mm, dy=8mm, dz=5mm,Complete
Maximum location: X=-56.000000, Y=-36.000000
SAR 10g (W/Kg): 0.193545
SAR 1g (W/Kg): 0.235929
Power drift (%): -0.66
3D screen shot

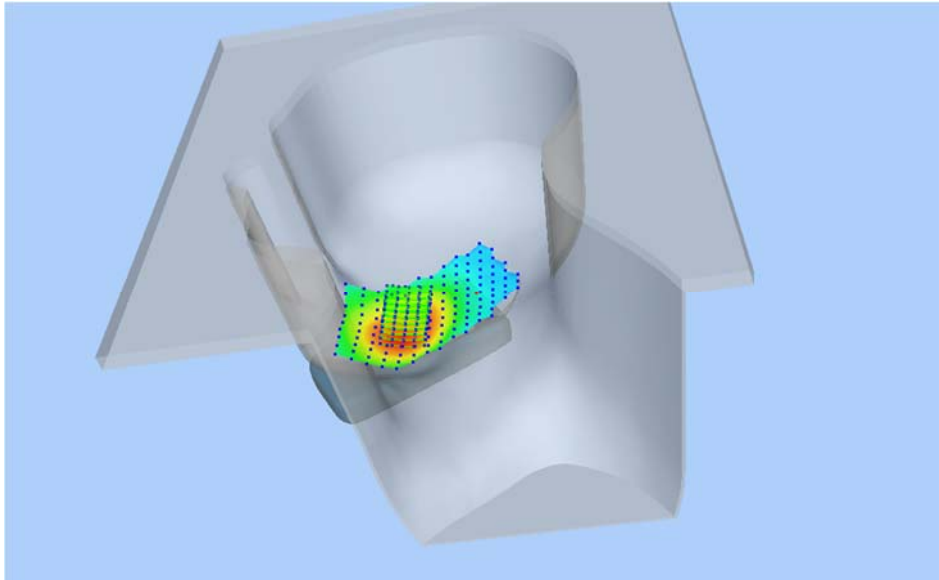

Z Axis Scan

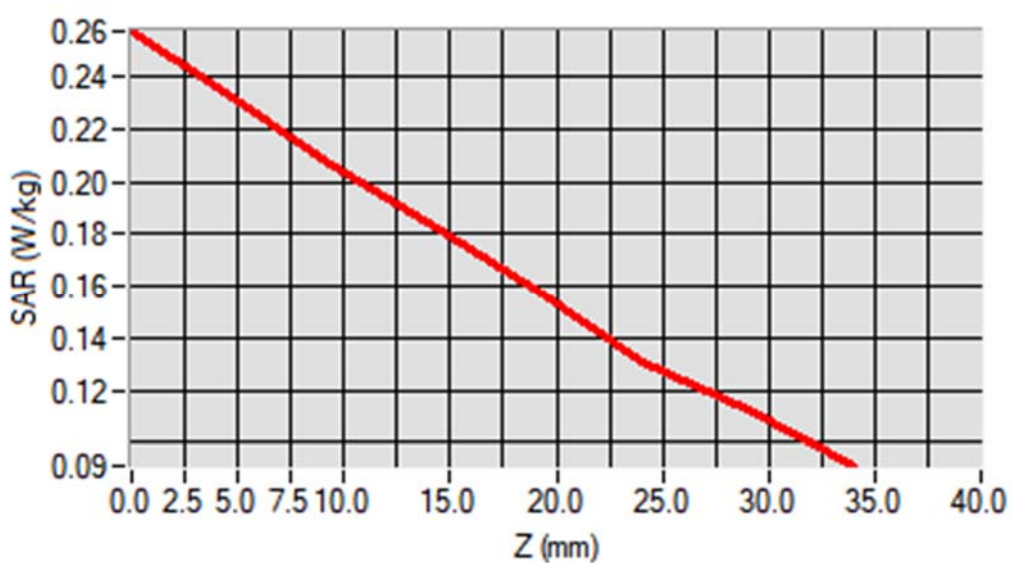

MEAS. 20 Body Plane with Back Side 10mm on Middle Channel in LTE Band12

mode

Test Date: 11/9/2019
Measurement duration: 10 minutes 30 seconds
Signal: LTE, f=707.5 MHz, Duty Cycle: 1:1.0
Liquid Parameters: Permittivity: 43.25; Conductivity: 0.89 S/m
Test condition: Ambient Temperature: 22.7°C, Liquid Temperature: 21.4°C
Probe: SN 34/15 SSE2 EPGO265, ConvF: 1.89
Area Scan: sam_direct_droit2_surf10mm.txt, h= 5.00 mm
Zoom Scan: 5x5x7,dx=8mm, dy=8mm, dz=5mm,Complete
Maximum location: X=-10.000000, Y=-32.000000
SAR 10g (W/Kg): 0.356613
SAR 1g (W/Kg): 0.453943
Power drift (%): 0.23
3D screen shot

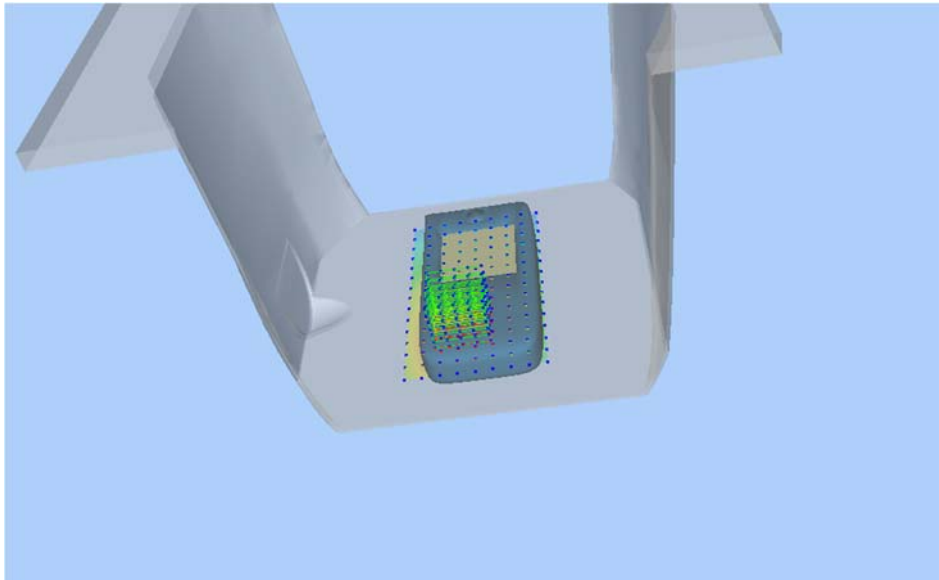

Z Axis Scan

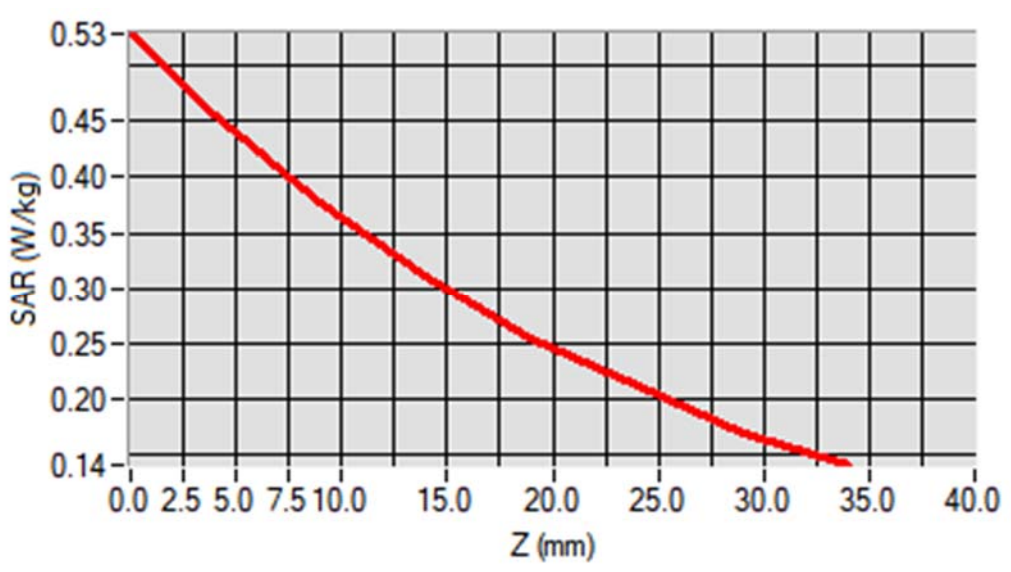

MEAS. 21 Right Head with Cheek on Middle Channel in LTE Band17 mode

Test Date: 11/9/2019
Measurement duration: 12 minutes 4 seconds
Signal: LTE, f=710.0 MHz, Duty Cycle: 1:1.0
Liquid Parameters: Permittivity: 42.91; Conductivity: 0.90 S/m
Test condition: Ambient Temperature: 22.7°C, Liquid Temperature: 21.4°C
Probe: SN 34/15 SSE2 EPGO265, ConvF: 1.89
Area Scan: sam_direct_droit2_surf10mm.txt, h= 5.00 mm
Zoom Scan: 5x5x7,dx=8mm, dy=8mm, dz=5mm,Complete
Maximum location: X=-56.000000, Y=-36.000000
SAR 10g (W/Kg): 0.221380
SAR 1g (W/Kg): 0.270052
Power drift (%): -1.46
3D screen shot

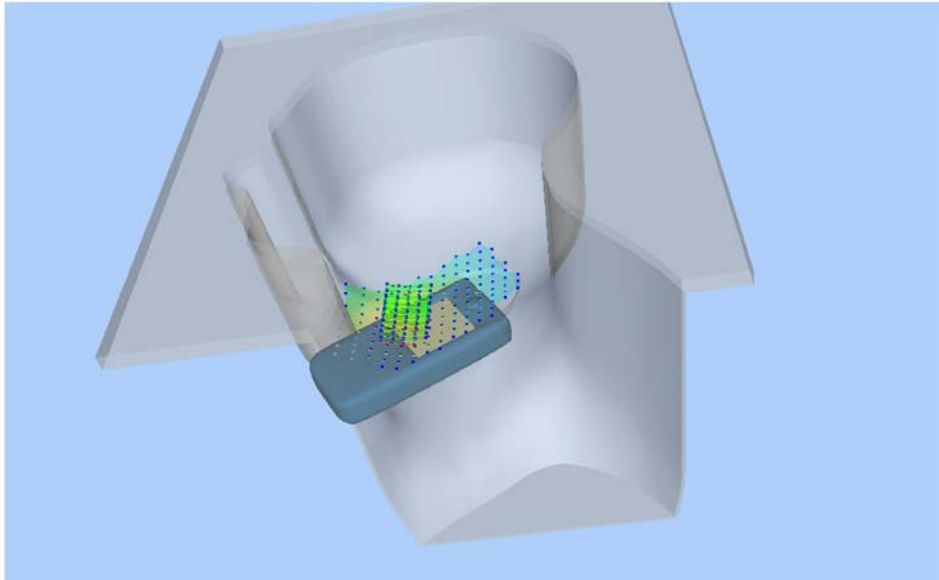

Z Axis Scan

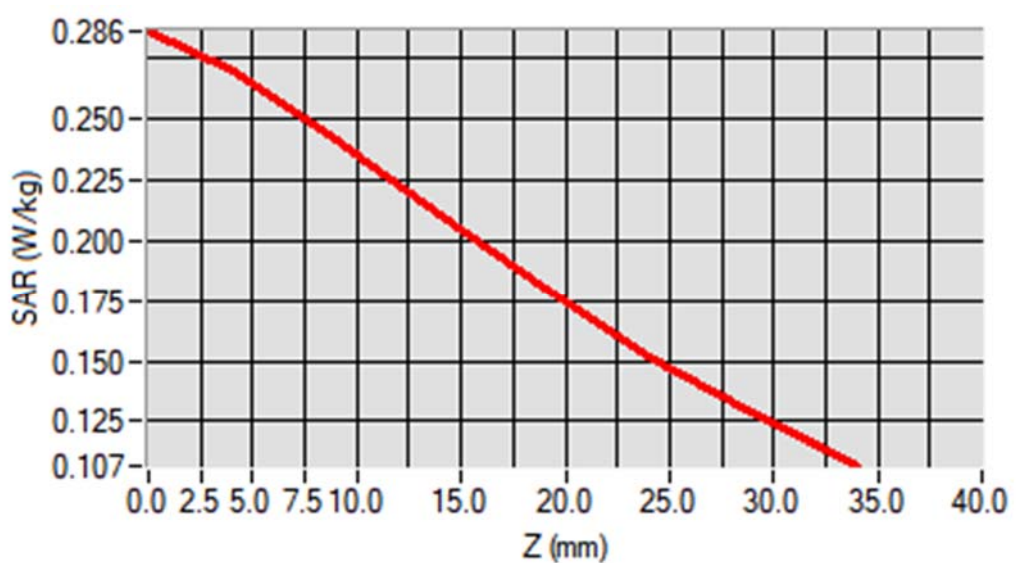

MEAS. 22 Body Plane with Back Side 10mm on Middle Channel in LTE Band17

mode

Test Date: 11/9/2019
Measurement duration: 11 minutes 32 seconds
Signal: LTE, f=710.0 MHz, Duty Cycle: 1:1.0
Liquid Parameters: Permittivity: 42.91; Conductivity: 0.90 S/m
Test condition: Ambient Temperature: 22.7°C, Liquid Temperature: 21.4°C
Probe: SN 34/15 SSE2 EPGO265, ConvF: 1.89
Area Scan: sam_direct_droit2_surf10mm.txt, h= 5.00 mm
Zoom Scan: 5x5x7,dx=8mm, dy=8mm, dz=5mm,Complete
Maximum location: X=-10.000000, Y=-32.000000
SAR 10g (W/Kg): 0.363683
SAR 1g (W/Kg): 0.462513
Power drift (%): -0.16
3D screen shot

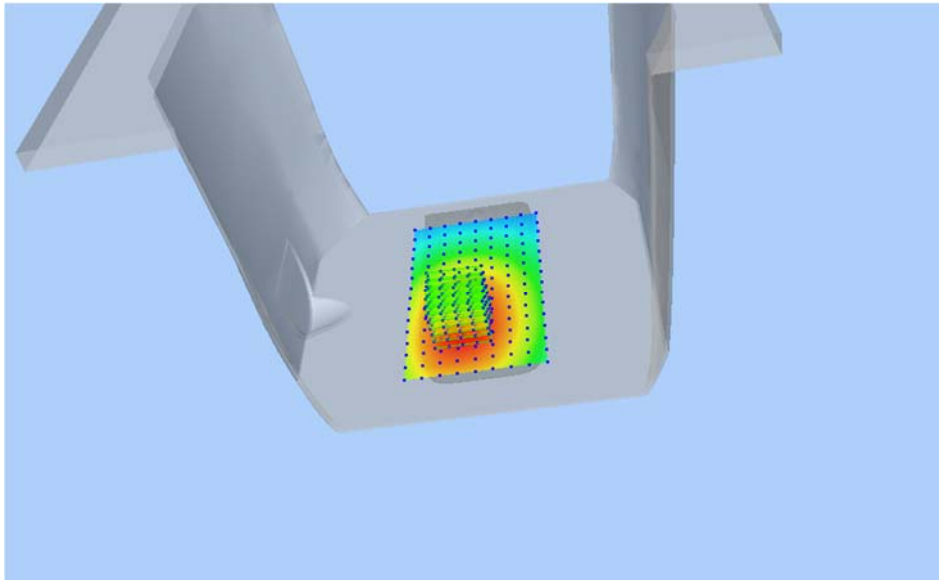

Z Axis Scan

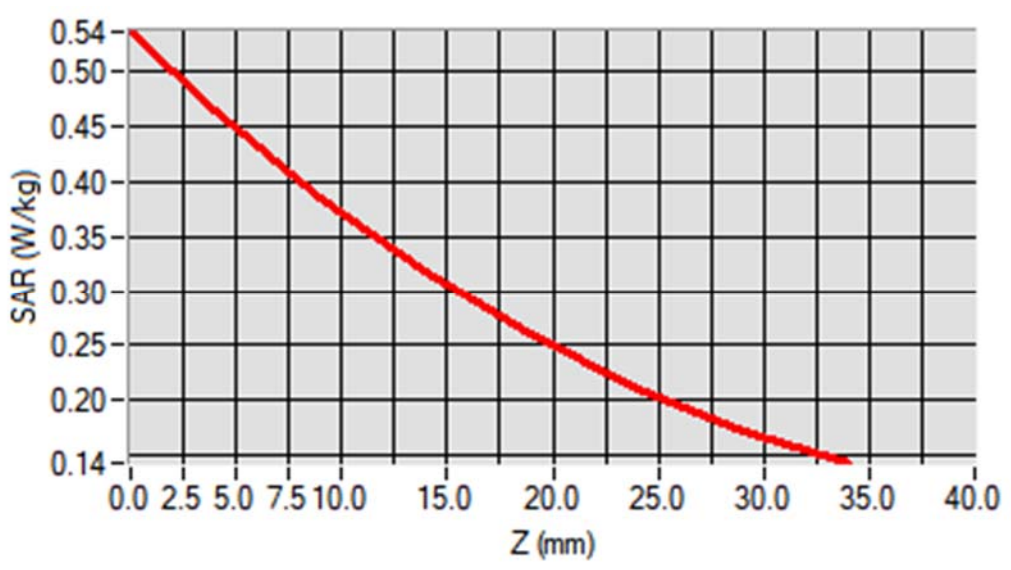

MEAS. 23 Right Head with Cheek on Middle Channel in IEEE 802.b mode

Test Date: 9/9/2019
Measurement duration: 15 minutes 37 seconds
Signal: WLAN, f=2437.0 MHz, Duty Cycle: 1:1.01
Liquid Parameters: Permittivity: 39.46; Conductivity: 1.79 S/m
Test condition: Ambient Temperature: 22.5°C, Liquid Temperature: 21.1°C
Probe: SN 34/15 SSE2 EPGO265, ConvF: 2.55
Area Scan: sam_direct_droit2_surf10mm.txt, h= 5.00 mm
Zoom Scan: 7x7x7,dx=5mm, dy=5mm, dz=5mm,Complete
Maximum location: X=-26.000000, Y=14.000000
SAR 10g (W/Kg): 0.201373
SAR 1g (W/Kg): 0.459601
Power drift (%): -1.64
3D screen shot

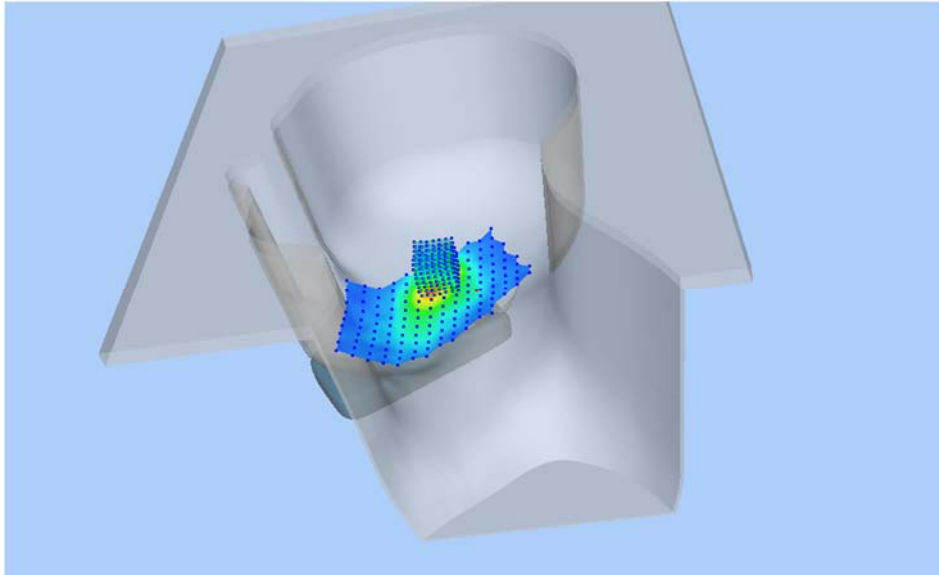

Z Axis Scan

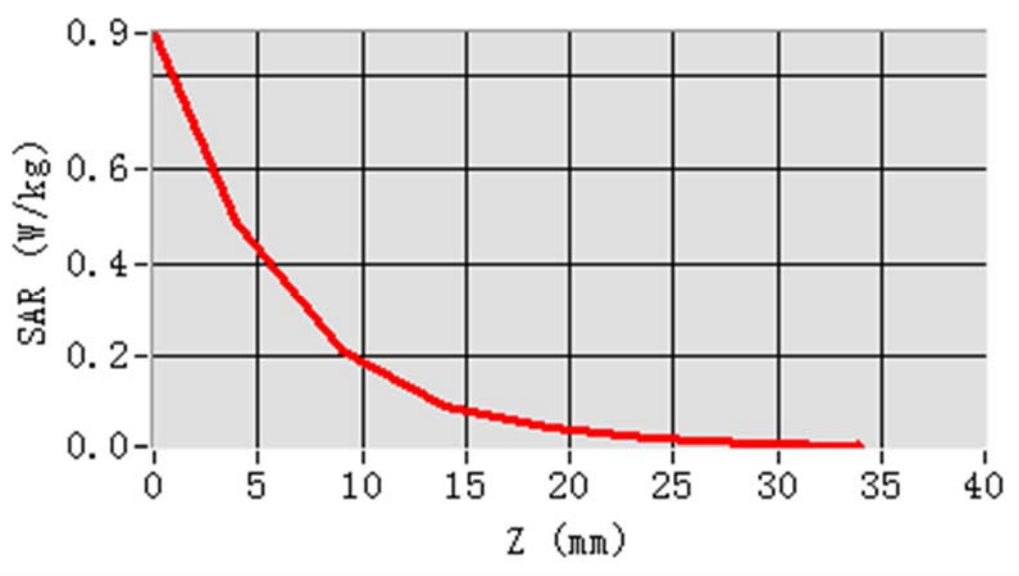

MEAS. 24 Body Plane with Back Side 10mm on Middle Channel in IEEE 802.b

mode

Test Date:	9/9/2019
Measurement duration:	16 minutes 52 seconds
Signal:	WLAN, f=2437.0 MHz, Duty Cycle: 1:1.01
Liquid Parameters:	Permittivity: 39.46; Conductivity: 1.79 S/m
Test condition:	Ambient Temperature: 22.5°C, Liquid Temperature: 21.1°C
Probe:	SN 34/15 SSE2 EPGO265, ConvF: 2.55
Area Scan:	sam_direct_droit2_surf10mm.txt, h= 5.00 mm
Zoom Scan:	7x7x7,dx=5mm, dy=5mm, dz=5mm,Complete
Maximum location:	X=0.000000, Y=38.000000
SAR 10g (W/Kg):	0.080998
SAR 1g (W/Kg):	0.174379
Power drift (%):	-0.17
3D screen shot	

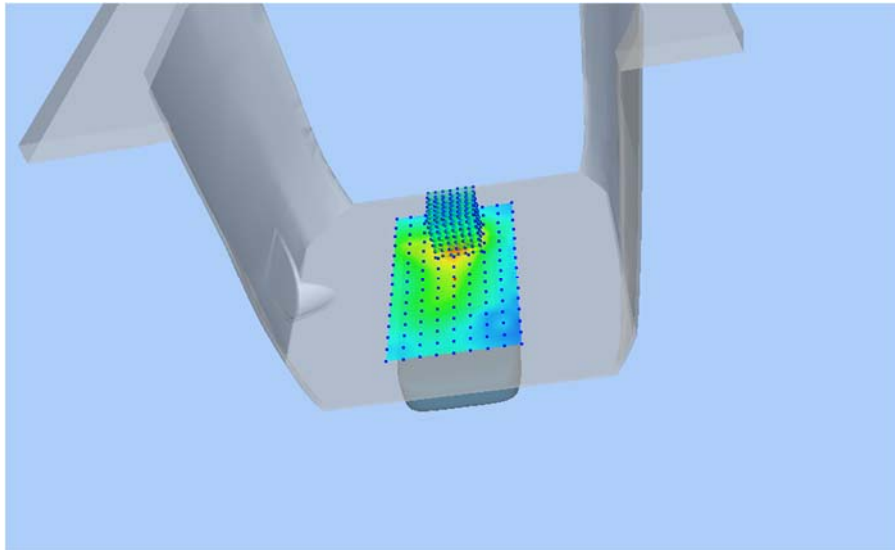

Z Axis Scan

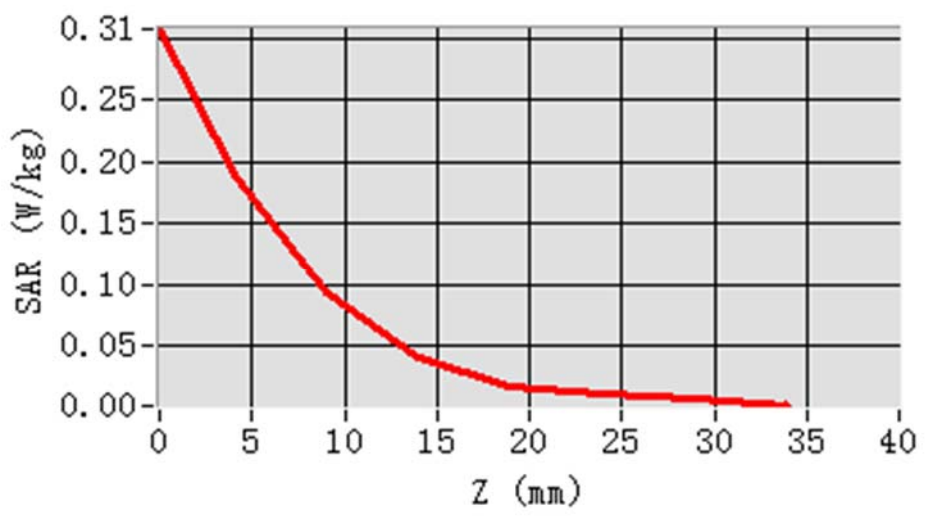

ANNEX D EUT EXTERNAL PHOTOS

Please refer the document "BL-SZ1970095-AW.pdf".

ANNEX E SAR TEST SETUP PHOTOS

Please refer the document "BL-SZ1970095-AS.pdf".

ANNEX F CALIBRATION REPORT

Please refer the document "CALIBRATION REPORT.pdf".

--END OF REPORT--