

Smart Battery Video Doorbell

# User Instructions

# Table of contents

## What's included ..... 1

---

## Get to know your doorbell ..... 2

Doorbell front view	2
Functional views	3
Chime front view	4
Chime rear view	4

---

## Set up your doorbell ..... 5

Downloading and installing the app	5
Doorbell binding	6
Doorbell sharing	8
Power on/off & Network configuration	9
Connecting the chime	9
Charging your doorbell	12

## Installation ..... 13

Choose the right place to install	13
Wireless installation	18
Installing at an angle(optional)	21
Detach and alarm	24

---

## Product specifications ..... 25

LED indicator explanation	25
Video doorbell specifications	26
Wireless chime specifications	27

---

## Firmware upgrade ..... 28

---

## FAQ and troubleshooting ..... 28

# What's included



Doorbell



Flat mounting  
bracket



3M tape



Doorbell chime

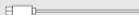

USB cable



Wall screw  
(wall anchor)



Wedge screw



Removal pin

**Note**

Micro SD card and power  
adapter are not included

# Get to know your doorbell

## Doorbell front view

- ① Lens
- ② Speaker
- ③ Human body infrared sensor
- ④ Doorbell button
- ⑤ Removal hole
- ⑥ Infrared light
- ⑦ Microphone
- ⑧ Indicator light

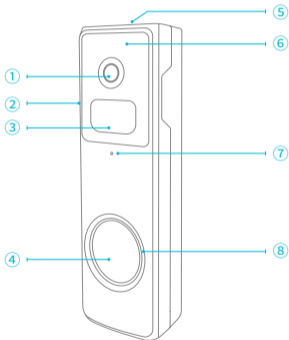

## Functional views

Right side  
Functional  
views ►

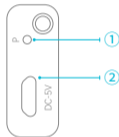

Bottom side  
Functional  
views ►



- ① Reboot hole
- ② Micro-USB port
- ③ Power button
- ④ Micro-SD card slot

## Chime front view

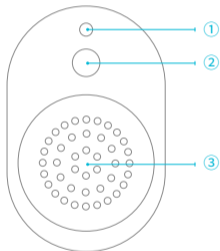

## Chime rear view

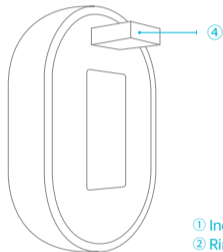

- ① Indicator light
- ② Ringtone selection key / "SYNC" key
- ③ Speaker
- ④ USB port

# Set up your doorbell

## Downloading and installing the app

The doorbell can be connected to and operated through smart phones running on Android and iOS platforms. For your best experience, please scan the QR code below, download and install the latest version app and follow the prompts to complete user registration.



App Download



## Doorbell binding

1) Click the **"Add Now"** button in the app, press and hold the doorbell switch button for 3 seconds to turn on the doorbell, and the app will automatically search for devices that are on and not bound. Select the device you want to bind in the search results for the next step.

2) Enter the name and password of the Wi-Fi network you want the doorbell to connect to. Click **"Next"** after completion, and the app will try to connect the doorbell to the Wi-Fi.

### Note

To ensure a long-distance connection, the doorbell only supports a 2.4 GHz Wi-Fi network with stronger wall penetration capability and does not support Wi-Fi with enterprise-level authentication. Please make sure that your Wi-Fi meets the requirements.

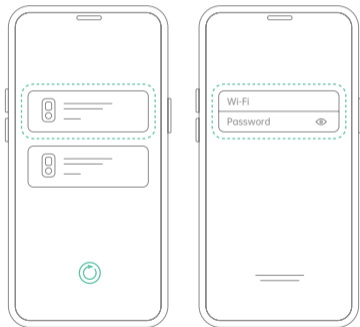



3) After a while, the doorbell will play a sound indicating that the connection is successful. At this point, please set a name for the doorbell on the app and select the location where you want to place the doorbell. Click Finish to complete the pairing.

## I Possible problems with binding

- When you hear "**Password error**", check if the Wi-Fi password you entered in the app is correct;
- When you hear "**Authentication method error**", please make sure that your Wi-Fi network is not in an enterprise-level network connection mode, as the doorbell only supports networks with a security level below WPA-2;
- When you hear "**AP does not exist**", please check if you have selected or entered the correct Wi-Fi name. Please place the doorbell near the Wi-Fi router and make sure the router is powered on. Also, please note that 5 GHz Wi-Fi cannot be searched by the doorbell either;
- When you hear "**IP acquisition timeout**", it means that you have too many devices connected to the router and to connect more devices, please delete some infrequently used devices or reboot the router to clear the unconnected doorbell whose lease has expired, and you may need to contact the router administrator;
- When you hear "**Server connection failed**", please check if your router is properly connected to the external network. This is usually the case when your home network is disconnected or the router you choose is a server on the LAN. Please make sure the network connection is normal, and try to connect again by temporarily turning off the firewall.

## Doorbell sharing

You can use this feature when you need to use the doorbell with other family members or friends. Only the admin user who has bound the doorbell for the first time can share and set up the doorbell, while other members can only view the live video or video playback feature of the doorbell.

1) For admin user of the doorbell, find the doorbell you wish to share on the app homepage or doorbell settings screen, then click the share button and enter the Share page. Click "**Device Sharing**" to generate a shared QR code.

2) For users who need to be shared with, click "+" on the homepage and select "**Add Friend's Device**" to enter the scan code page.

3) After the shared user successfully scans the QR code on the admin user's mobile phone, the admin user will receive a confirmation notification, then click "**Accept**" to complete the doorbell sharing.

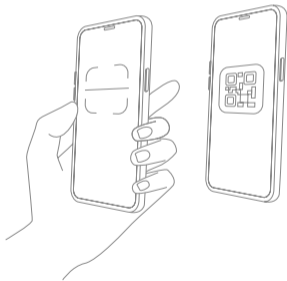

## Power on/off & Network configuration

The power button can control the doorbell on/off function or enter the network configuration mode. You need to first remove the doorbell from the bracket before the button can be pressed.

- Insert and press the detaching pin into the hole on the top of the doorbell and then lift to take the top of the doorbell off.
- Press and hold the power button for 3 seconds to switch the device on and off.
- Double-click the power button on the doorbell that has been powered on and a prompt tone will sound indicating to enter the network configuration mode.

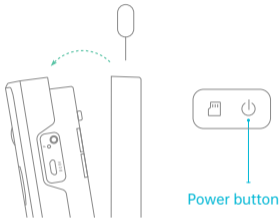

## Connecting the chime

### 1) **Connecting the doorbell chime with a charger**

Connect the doorbell chime to the power supply of 5V/1A~5V/2A, and the doorbell chime will ring once.

## 2) Bringing your doorbell close to the chime

Move the doorbell within 2 meters of the doorbell Chime, so that the doorbell and the doorbell chime can be paired stably.

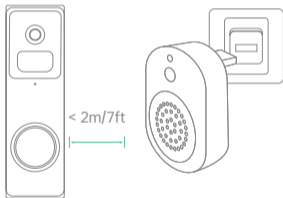

## 3) Putting the doorbell chime into sync state

Press and hold the pairing button on the front of the indoor Ding Dong until you hear a beep.

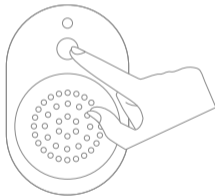

#### 4) Synchronizing the doorbell with the chime

Press and hold the doorbell button for 6 seconds, the doorbell will ring twice, send a connection signal, and the doorbell chime will ring.

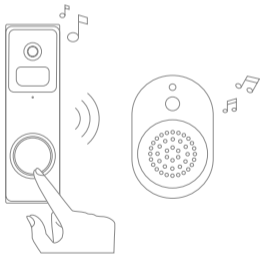

#### 5) Connection Successful

Press the doorbell button for testing. When a chime rings, it indicates that the connection is successful.

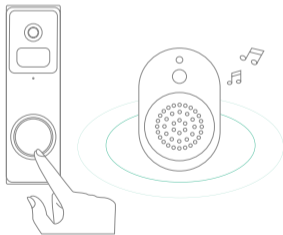

**Note**

- Your doorbell communicates with the chime via Radio Frequency, but not Wi-Fi.
- You can assign different chimes as needed.
- If you want to cancel the pairing relationship, you can long press the indoor Dingdong synchronization button for 8s.

## Charging your doorbell

Before the doorbell installation, please charge your doorbell. During the charging process, the yellow indicator light of the doorbell is always on, and then it will become solid green when the charging is completed. It may take about 10 hours to fully charge the doorbell.

**Note**

- Compatible charger (not included)
- USB compatible mobile phone charger (DC 5V 1A-2A)

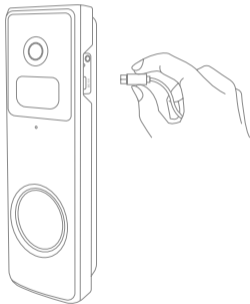

# Installation

## Choose the right place to install

### You need

- The items in the Smart Video Doorbell box
- Phillips screwdriver
- (Optional) power drill

### 1) **Select a location for your video doorbell.**

Determine the mounting position of the doorbell. Check if you can reuse the existing holes on the wall, if you don't want to drill new holes to mount your video doorbell.

It is suggested to mount the doorbell at least 5 feet (150 cm) above the ground for the optimal angle of view and best motion detection performance.

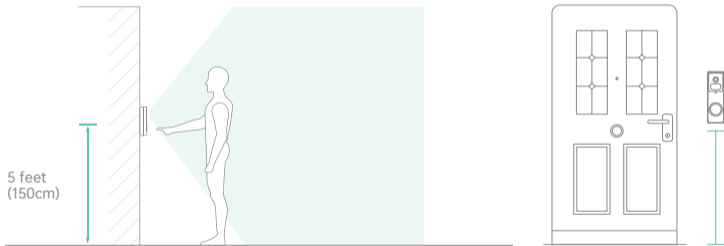

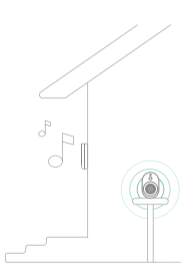

**Note**

- The doorbell, indoor unit, and router need to be as close as possible (to avoid networking failure due to distance).
- The doorbell should be installed on non-metallic porches and walls (to avoid signal shielding) or affixed to the wall on the door side.

2) If installing on stucco, brick, or concrete, mark 2 drill holes using the doorbell bracket as a template. Then, use a 1/4" masonry drill bit to drill holes in your wall, and insert the included anchors. (If you're installing on a wood surface, skip this step.)

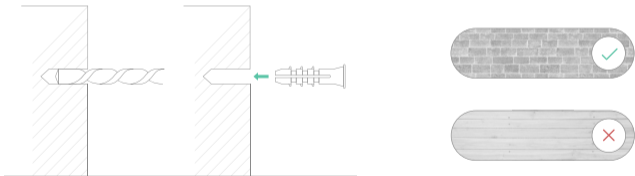

mounting order ►

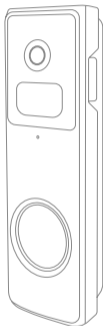
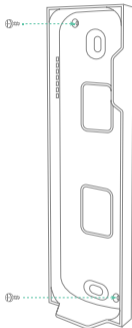
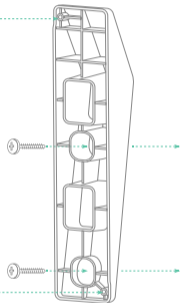
Smart Video  
Doorbelldoorbell  
bracketAngled mounting wedge  
(optional)

## Wireless installation

1) Release the bracket from the doorbell with the provided tool.

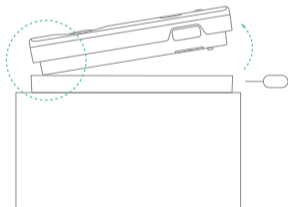

2) Mark the screw holes and mount the bracket on your wall with screws.

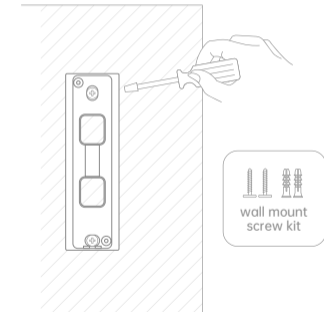

3) Adhesive tape is provided to mount the bracket on flat surfaces. (Optional)

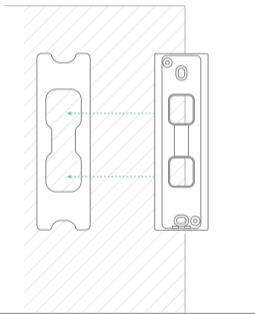

Note

When mounting the doorbell with 3M adhesive pad, in order to improve the adhesive pad's adhesive effect, please wipe the mounting location to ensure that there is no dirt and dust. when the 3M adhesive pad is attached to the wall, you need to press evenly up and down to ensure that the adhesive pad is fully activated.

4) Attach the doorbell to the fixed mounting bracket.

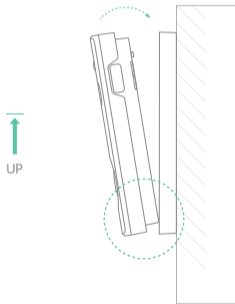

5) All set! Press the doorbell button to run a test.

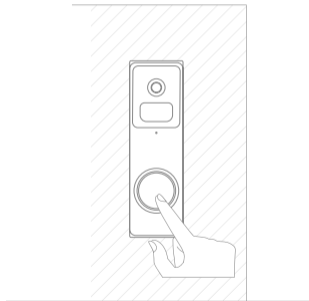

## Install at an angle (optional)

You can purchase the following angled brackets to point your doorbell to a specific view angle.

Doorbell Bracket  
Rear View ▶

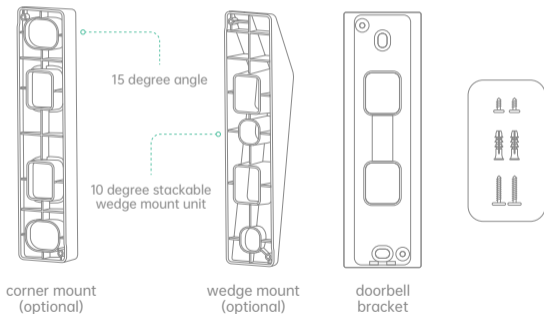

## I Installation steps

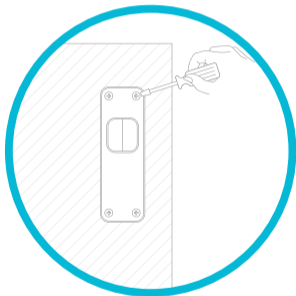

- 1) If you have an existing doorbell, please remove it.
- 2) Mark the screw holes and mount the angle bracket on your wall with screws.
- 3) Mark the screw holes and mount the plane bracket on the angle bracket with screws.
- 4) After fixing the screws, the installation is completed.



schematic diagram ►

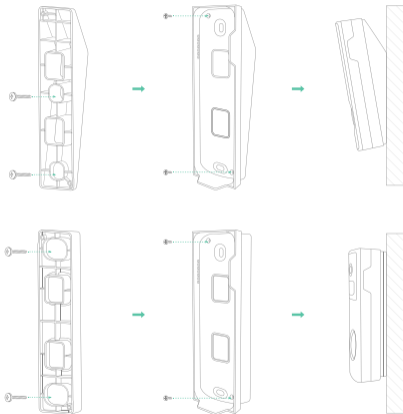

## Detach and alarm

### 1) Anti-theft Tamper Alarm

You can also enable the anti-theft alarm in doorbell settings.

### 2) Tamper Alarm On

With the tamper alarm on, your doorbell detects dismounting activities with the button on its back, and then a 30-second siren alarm will be triggered. Meanwhile, video recording will start, and an alarm notification will be pushed to the owner's app account.

### 3) Tamper Alarm Off

You can disable the tamper alarm in doorbell settings, and detach the doorbell without triggering any alarm for battery recharge or regular maintenance.

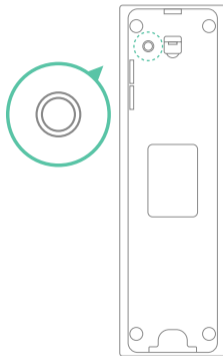

# Product specifications

I LED indicator explanation	
Mode	Status
Working mode	Solid blue light
Sleep mode	Off
Charging mode	Solid yellow light
Charging completed	Solid green light
Network setting up mode	Flashing blue light

## I Video doorbell specifications

Item	Specification
Camera	2M Camera
View angle	FOV 150
Image resolution	1920(H) x 1080(V)
Video bitrate	Adaptive
Storage medium	Micro SD card (up to 128 GB)
Battery capacity	5000 mAh
Adapter requirements	5 V/1.5 A
Dimension	152×46×31 (mm)

## I Wireless chime specifications

Item	Specification
Power port	USB
Ringtone type	Chord music
Volume	80db (Nonadjustable)
Communication protocol	OOK
Adapter requirements	5V/1A or 1.5A
Dimension	64×45×18 (mm)

# Firmware upgrade

When you connect your doorbell via the app, it will automatically detect if there is a new firmware available and prompt for an upgrade. You can also manually detect the firmware upgrade in the app's doorbell settings.

## Note

Please make sure your doorbell is fully charged or connected to the power adapter before the firmware upgrade, and do not turn off your doorbell during the upgrade process.

# FAQ and troubleshooting

Q: **Does the doorbell glow red when using its night vision?**

A: It has built-in infrared light beads. Only a faint red light can be seen under the night vision mode, and the camera is still clear in a dark environment.

Q: **What are the requirements for Wi-Fi?**

A: Please use a 2.4 GHz wireless network. The doorbell does not support the 5 GHz wireless network. Meanwhile, please set the Wi-Fi authentication method to a security method below wpa2-psk, which requires a password.

**Q: How far away from the router should the doorbell be placed?**

A: It has been tested that the Wi-Fi connection distance is up to 150 meters in an open environment. The actual situation depends on the Wi-Fi signal strength and the surrounding environment (too thick walls, electromagnetic wave doorbells, and large metal objects can interfere with the Wi-Fi signal). If the doorbell connection signal is weak or unstable, please place the doorbell as close to the router as possible.

**Q: How can I review videos in a quick and categorized way?**

A: Click the icon on the top left corner of the "Library" screen to set filtering conditions, check the conditions and save them to quickly review the video playback by category.

**Q: What should I do when the doorbell acts abnormally?**

A: After taking the doorbell off the bracket, press and hold the power button for 3 seconds to reboot it. If it doesn't respond, you can reset the doorbell by poking the reset hole with a pin.

#### FCC Warning

This device complies with part 15 of the FCC rules. Operation is subject to the following two conditions: (1) this device may not cause harmful interference, and (2) this device must accept any interference received, including interference that may cause undesired operation.

Changes or modifications not expressly approved by the party responsible for compliance could void the user's authority to operate the equipment.

NOTE: This equipment has been tested and found to comply with the limits for a Class B digital device, pursuant to part 15 of the FCC Rules. These limits are designed to provide reasonable protection against harmful interference in a residential installation. This equipment generates uses and can radiate radio frequency energy and, if not installed and used in accordance with the instructions, may cause harmful interference to radio communications. However, there is no guarantee that interference will not occur in a particular installation. If this equipment does cause harmful interference to radio or television reception, which can be determined by turning the equipment off and on, the user is encouraged to try to correct the interference by one or more of the following measures:

- Reorient or relocate the receiving antenna.
- Increase the separation between the equipment and receiver.
- Connect the equipment into an outlet on a circuit different from that to which the receiver is connected.
- Consult the dealer or an experienced radio/TV technician for help.

#### Radiation Exposure Statement

This equipment complies with FCC radiation exposure limits set forth for an uncontrolled environment. This equipment should be installed and operated with minimum distance 20cm between the radiator and your body.



